

### FEATURES

- Available as "HR" (high reliability) screened per MIL-PRF-19500, JANTX level. Add "HR" suffix to base part number.
- Available as non-RoHS (Sn/Pb plating), standard, and as RoHS by adding "-PBF" suffix.

### MAXIMUM RATINGS

Rating	Symbol	Value	Unit
<b>Peak repetitive off-state voltage</b> ( $T_j = -65$ to $+125^\circ\text{C}$ ) (1/2 sine wave 50 to 60Hz, gate open) 2N6157, 2N6160, 2N6163 2N6158, 2N6161, 2N6164 2N6159, 2N6162, 2N6165	$V_{\text{DRM}}$	200 400 600	Volts
<b>Peak gate voltage</b>	$V_{\text{GM}}$	10	Volts
<b>RMS on-state current</b> (full sine wave, 50 to 60Hz) ( $T_c = -65$ to $+85^\circ\text{C}$ ) ( $T_c = 100^\circ\text{C}$ )	$I_{\text{T(RMS)}}$	30 20	Amps
<b>Peak non-repetitive surge current</b> (1 cycle, sine wave, 60 Hz preceded and followed by a 30A RMS current, $T_c = 85^\circ\text{C}$ )	$I_{\text{TSM}}$	250	Amps
<b>Circuit fusing considerations</b> ( $t = 8.3\text{ms}$ )	$I^2t$	260	$\text{A}^2\text{s}$
<b>Peak gate power</b> ( $T_j = 80^\circ\text{C}$ , pulse width = $2\mu\text{s}$ )	$P_{\text{GM}}$	20	Watts
<b>Average gate power</b> ( $T_j = 80^\circ\text{C}$ , $t = 8.3\text{ms}$ )	$P_{\text{G(AV)}}$	0.5	Watts
<b>Peak gate current</b>	$I_{\text{GM}}$	2.0	Amps
<b>Operating junction temperature range</b>	$T_j$	-65 to +125	$^\circ\text{C}$
<b>Storage temperature range</b>	$T_{\text{stg}}$	-65 to +150	$^\circ\text{C}$
<b>Stud torque</b>		30	In. lb.

### THERMAL CHARACTERISTICS

Characteristic	Symbol	Maximum	Unit
Thermal resistance, junction to case	$R_{\theta\text{JC}}$	1	$^\circ\text{C}/\text{W}$

**ELECTRICAL CHARACTERISTICS @ 25°C unless otherwise noted**

Characteristic	Symbol	Min	Typ.	Max	Unit
<b>Peak forward or reverse blocking current</b> (Rated $V_{DRM}$ Or $V_{RRM}$ @ $T_J = 25^\circ\text{C}$ ) (Rated $V_{DRM}$ Or $V_{RRM}$ @ $T_J = 125^\circ\text{C}$ )	$I_{DRM}, I_{RRM}$	-	-	10 2	$\mu\text{A}$ mA
<b>Peak on-state voltage</b> (either direction) ( $I_{TM} = 42\text{A}$ peak, pulse width = 1 to 2 ms, duty cycle $\leq 2\%$ )	$V_{TM}$	-	1.5	2.0	Volts
<b>Gate trigger current</b> (continuous dc) <sup>(1)</sup> (Main terminal voltage = 12V, $R_L = 50\Omega$ ) MT2(+),G(+) MT2(+),G(-) MT2(-),G(-) MT2(-),G(+) MT2(+),G(+); MT2(-), G(-) $T_C = -65^\circ\text{C}$ MT2(+),G(-); MT2(-), G(+) $T_C = -65^\circ\text{C}$	$I_{GT}$	-	15 20 20 30 - -	60 70 70 100 200 250	mA
<b>Gate trigger voltage</b> (continuous dc) (Main terminal voltage = 12V, $R_L = 50\Omega$ ) MT2(+),G(+) MT2(+),G(-) MT2(-),G(-) MT2(-),G(+) All quadrants Main terminal voltage = rated $V_{DRM}$ , $R_L = 10k\Omega$ , $T_J = 125^\circ\text{C}$	$V_{GT}$	-	0.8 0.7 0.85 1.1 - -	2 2.1 2.1 2.5 3.4 -	Volts
<b>Holding current</b> (Main terminal voltage = 12V, gate open) (initiating current = 500mA) MT2(+) MT2(-) Either direction, $T_C = -65^\circ\text{C}$	$I_H$	-	8 10 -	70 80 200	mA
<b>Turn on time</b> (Main terminal voltage = rated $V_{DRM}$ , $I_{TM} = 42\text{A}$ , gate source voltage = 12V, $R_S = 50\Omega$ , rise time = 0.1 $\mu\text{s}$ , pulse width = 2 $\mu\text{s}$ )	$t_{gt}$	-	1	2	$\mu\text{s}$
<b>Blocking voltage application rate at commutation,</b> $f = 60\text{Hz}$ , $T_C = 85^\circ\text{C}$ <b>On state conditions:</b> ( $I_{TM} = 42\text{A}$ , pulse width = 4ms, $di/dt = 17.5\text{A/ms}$ ) <b>Off-state conditions:</b> (Main terminal voltage = rated $V_{DRM}$ , 200 $\mu\text{s}$ min., gate source voltage = 0V, $R_S = 50\Omega$ )	$dv/dt(c)$	-	5	-	V/ $\mu\text{s}$

### MECHANICAL CHARACTERISTICS

<b>Case</b>	Digi PF2 (2N6157-2N6159)
<b>Marking</b>	Body painted, alpha-numeric

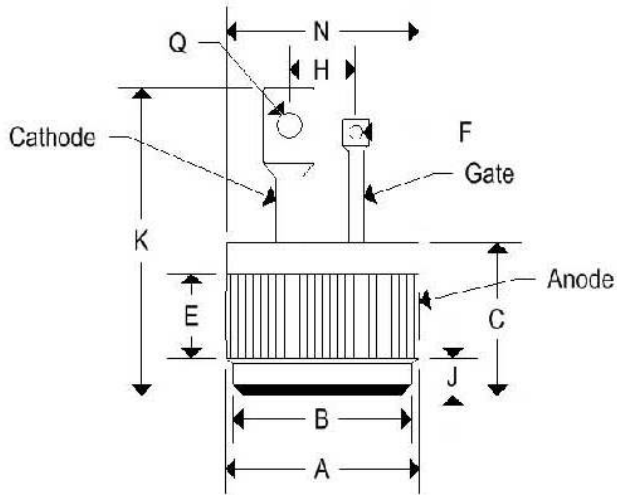

	DIGI PF2			
	Inches		Millimeters	
	Min	Max	Min	Max
<b>A</b>	0.501	0.505	12.730	12.830
<b>B</b>	0.465	0.475	11.810	12.060
<b>C</b>	0.330	0.380	8.390	9.650
<b>E</b>	0.100	-	2.540	-
<b>F</b>	0.035	0.085	0.890	2.160
<b>J</b>	0.080	0.097	2.040	2.460
<b>K</b>	-	0.800	-	20.320
<b>N</b>	-	0.510	-	12.950
<b>Q</b>	0.065	0.160	1.650	4.060

# 2N6157-2N6165

## THYRISTORS

### MECHANICAL CHARACTERISTICS

Case	TO-48 (2N6160-2N6162)
Marking	Alpha-numeric
Pin out	See below

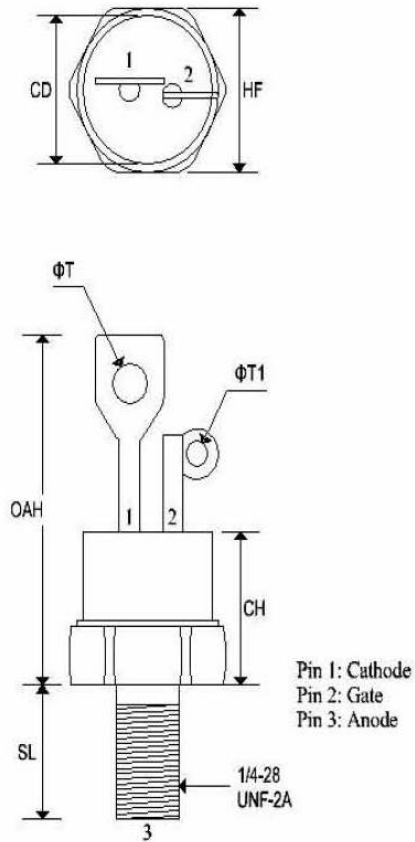

	TO-48			
	Inches		Millimeters	
	Min	Max	Min	Max
CD	-	0.543	-	13.793
CH	-	0.550	-	13.970
HF	0.544	0.563	13.817	14.301
OAH	-	1.193	-	30.303
SL	0.422	0.453	10.718	11.507
ΦT	0.125	0.165	3.175	4.191
ΦT <sub>1</sub>	0.060	0.075	1.524	1.905

# 2N6157-2N6165

## THYRISTORS

### MECHANICAL CHARACTERISTICS

Case	TO-48 ISO (2N6163-2N6165)
Marking	Alpha-numeric
Pin out	See below

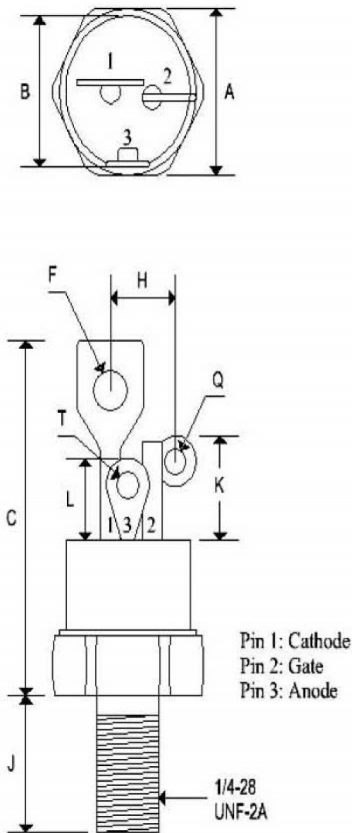

	TO-48 ISO			
	Inches		Millimeters	
	Min	Max	Min	Max
A	0.551	0.559	14.000	14.200
B	0.501	0.505	12.730	12.830
C	-	1.280	-	32.510
F	-	0.160	-	4.060
H	-	0.265	-	6.730
J	0.420	0.455	10.670	11.560
K	0.300	0.350	7.620	8.890
L	0.255	0.275	6.480	6.990
Q	0.055	0.085	1.400	2.160
T	0.135	0.150	3.430	3.810

FIGURE 1 – RMS CURRENT DERATING

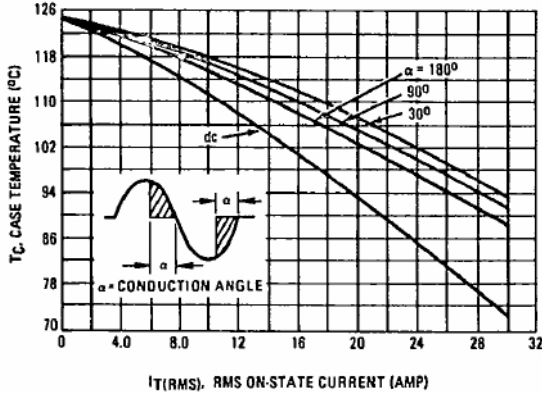

FIGURE 2 – POWER DISSIPATION

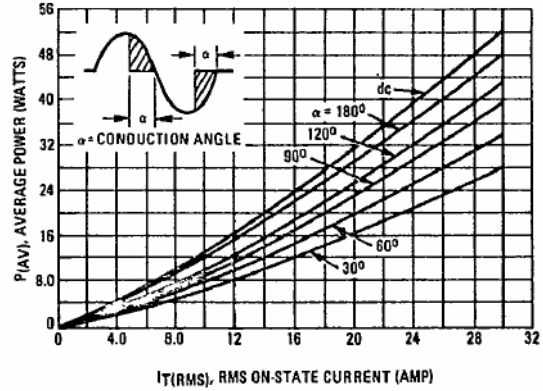

FIGURE 3 – TYPICAL GATE TRIGGER VOLTAGE

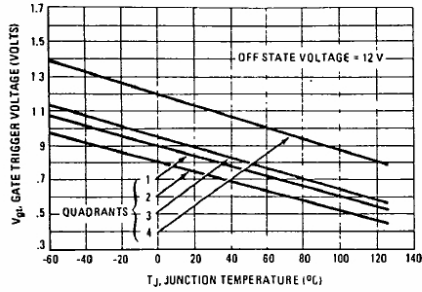

FIGURE 5 – MAXIMUM ON-STATE CHARACTERISTICS

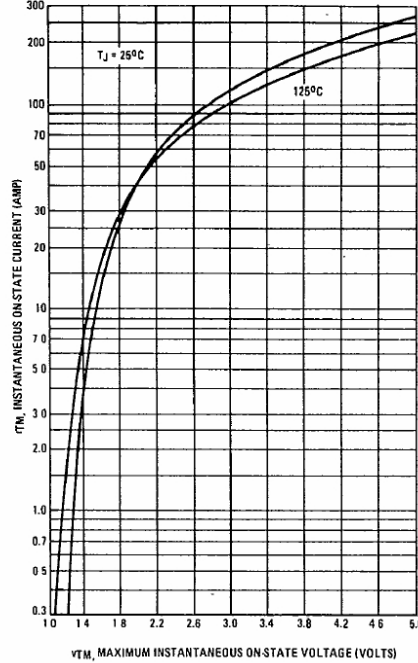

FIGURE 4 – TYPICAL GATE TRIGGER CURRENT

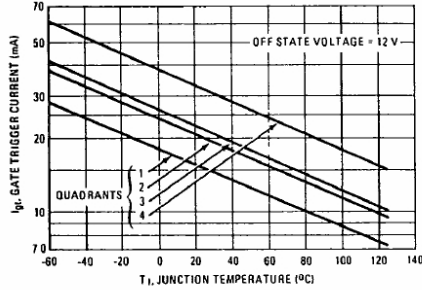

FIGURE 6 – TYPICAL HOLDING CURRENT

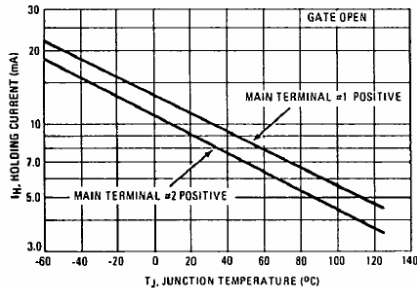

FIGURE 7 – MAXIMUM ALLOWABLE SURGE CURRENT

