

# 8mm X 573.5mm RGB LED LIGHT BAR

## FEATURES

VOLTAGE: 12V DC.

CURRENT: 600mA.

LED VIEWING ANGLE (2 θ 1/2): 100°.

PACKAGE: 1 PC/PVC TUBE.

PCB THICKNESS: 1.6mm

FULL COLOR CAPABILITY

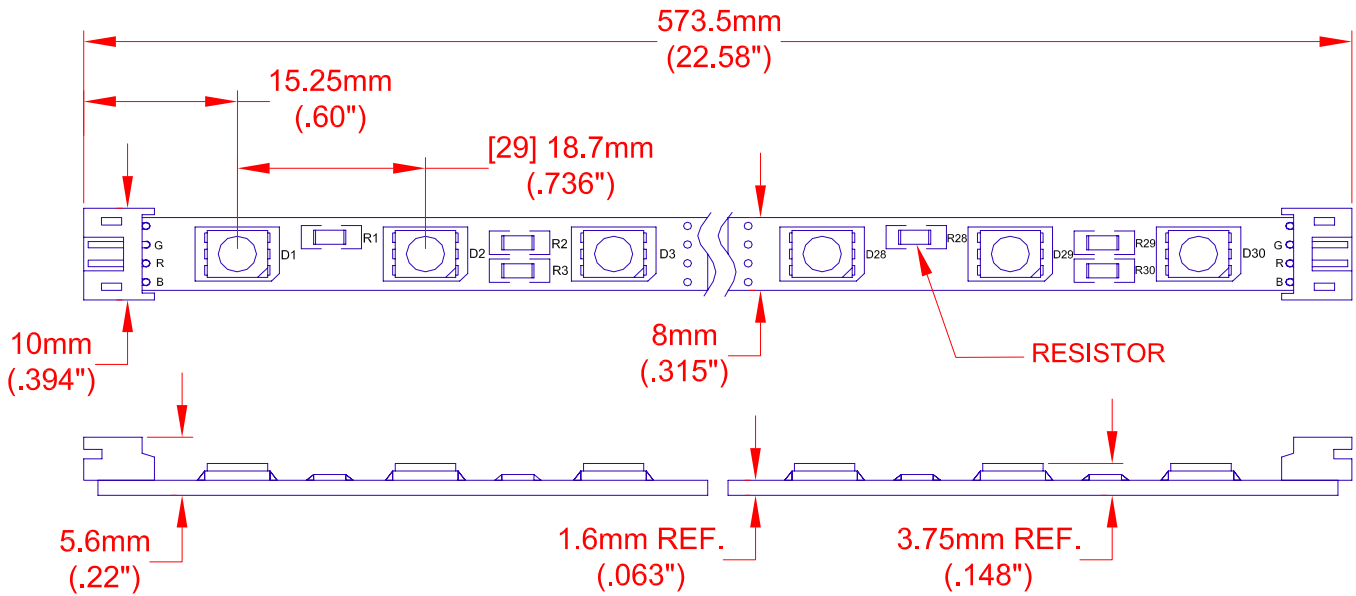

### ATTENTION



OBSERVE PRECAUTION FOR HANDLING ELECTROSTATIC DISCHARGE SENSITIVE DEVICES

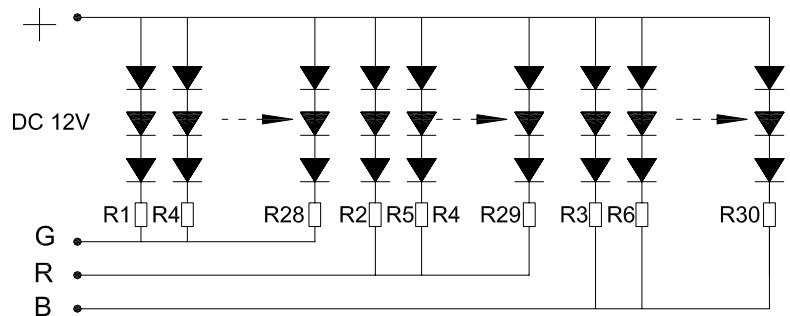

JKL PART NO.: ZRS-10573-RGB

<b>METRIC</b>  THIRD ANGLE PROJECTION		DIMENSIONS ARE IN MILLIMETERS TOLERANCE UNLESS OTHERWISE SPECIFIED 1 PL +/- REF. 2 PL +/- ANGLE +/-		<b>JKL COMPONENTS CORPORATION</b> TITLE <b>RGB LED LIGHT BAR</b>				
<b>B</b> ADD DIM'S & FEATURES <b>A</b> ADD ACCESSORIES NOTE PG 2 RELEASED	3/12/08 1/31/08 12/11/07	DRAWN BY L. WENGSTROM	APPV'D BY S.C.	DATE 3/12/08	SIZE <b>A</b>	FSCM NO. <b>55335</b>	DRAWING NO. <b>ZRS-10573-RGB</b>	
REV. NO. DESCRIPTION/ECO NUMBER	APPV'D DATE	- CAD DRAWING - MANUAL REVISIONS NOT PERMITTED		SCALE NONE	RELEASED DATE 12/11/07	REVISION DATE 3/12/08	REV. NO. <b>B</b>	SHEET 1 OF 2

# 8mm X 573.5mm RGB LED LIGHT BAR

## Absolute Maximum Rating at TA = 25°C

Parameter	Symbol	Absolute Maximum Rating	Unit
Forward Current	IF	600	mA
Power Dissipation	PD	7.2	W
Electrostatic Discharge	ESD	800	V
Operating Temperature	Topr	-25~+60	°C
Storage Temperature	Tstg	-40~+80	°C

## Electrical/Optical Characteristics at TA = 25°C

Parameter	Symbol	Color	Condition	Min	Typ	Max	Unit
Forward Voltage DC	VF	RGB	IF = 600mA	--	12	--	V
Dominant Wavelength	$\lambda D$	R	IF = 200mA	--	624	--	nm
		G	IF = 200mA	--	518	--	
		B	IF = 200mA	--	471	--	
Luminous Flux	$\phi V$	R	IF = 200mA	--	21	--	lm
		G	IF = 200mA	--	55	--	
		B	IF = 200mA	--	21	--	
Recommend Forward Current	IF	--	--	--	600	--	mA

JKL ACCESSORIES TO BE ORDERED SEPARATELY:

PCB MOUNTING CLIP: **ZRC-8**

INPUT CONNECTOR HARNESS: **ZCH-110-RGB-I**

JOINER CONNECTOR HARNESS: **ZCH-110-RGB-J**

LIGHTING COLOR REMOTE CONTROLLER: **ZCTR-01-RGB**