

REVISION BF

NOTES:

1. Ⓢ REPRESENTS A CRITICAL DIMENSION.
2. MINIMUM CONTACT PUSHOUT FORCE: 0.5 LB.
3. MAXIMUM ALLOWABLE BOW .003[0.08] IN/IN AFTER ASSEMBLY.
4. FOR A 1 POSITION SINGLE ROW ALL SPACERS ARE TO BE LBS-S.
5. NOTE DELETED.
6. SINGLE ROW, 33 POS PART TO USE 31 POS AND 2 POS SPACERS.
7. MAXIMUM CUT FLASH: .015.
8. ORDERS WILL BE PACKAGED ACCORDING TO THE SAMTEC PACKAGING EFFICIENCY STANDARDS (SPES) FOUND ON WWW.SAMTEC.COM

DO NOT SCALE FROM THIS PRINT

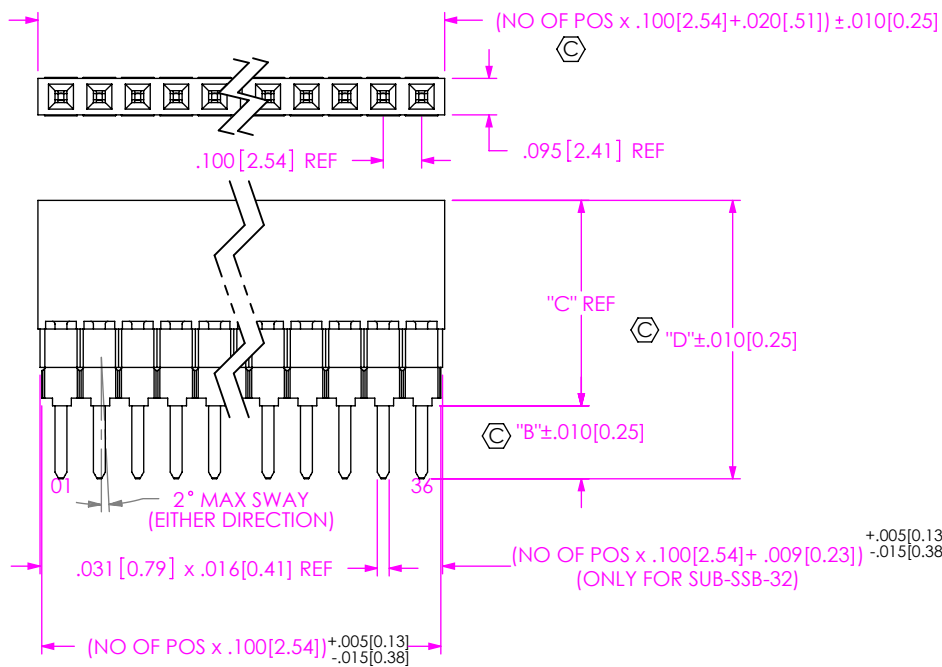


FIG 1  
ESW-1XX-XX-X-S SHOWN

STANDARD INSERTION FORCE	CONTACT	SPACER SPECIFICATION (SEE NOTE 4)		"B"	"C"	"D"	"E"
		ESW-S	ESW-D				
-12	C-8-2-X			.090 [2.29]	.435 [11.05]	.525 [13.34]	.100 [2.54]
-13	C-8-3-X			.290 [7.37]	.435 [11.05]	.725 [18.42]	N/A
-14	C-8-5-X			.480 [12.19]	.435 [11.05]	.915 [23.24]	N/A
-23	C-8-3-X	(1) SUB-SSB-32	(1) DSB-XX	.190 [4.83]	.535 [13.59]	.725 [18.42]	N/A
-24	C-8-5-X	(1) SUB-SSB-32	(1) DSB-XX	.380 [9.65]	.535 [13.59]	.915 [23.24]	N/A
-33	C-8-3-X	(2) SUB-SSB-32	(2) DSB-XX	.090 [2.29]	.635 [16.13]	.725 [18.42]	N/A
-34	C-8-5-X	(2) SUB-SSB-32	(2) DSB-XX	.280 [7.11]	.635 [16.13]	.915 [23.24]	N/A
-44	C-8-5-X	(1) ESS-XX-S	(3) DSB-XX	.180 [4.57]	.735 [18.67]	.915 [23.24]	N/A
LOW INSERTION FORCE							
-37	C-17-2-X			.090 [2.29]	.435 [11.05]	.525 [13.34]	.100 [2.54]
-38	C-17-3-X			.290 [7.37]	.435 [11.05]	.725 [18.42]	N/A
-39	C-17-5-X			.480 [12.19]	.435 [11.05]	.915 [23.24]	N/A
-48	C-17-3-X	(1) SUB-SSB-32	(1) DSB-XX	.190 [4.83]	.535 [13.59]	.725 [18.42]	N/A
-49	C-17-5-X	(1) SUB-SSB-32	(1) DSB-XX	.380 [9.65]	.535 [13.59]	.915 [23.24]	N/A
-58	C-17-3-X	(2) SUB-SSB-32	(2) DSB-XX	.090 [2.29]	.635 [16.13]	.725 [18.42]	N/A
-59	C-17-5-X	(2) SUB-SSB-32	(2) DSB-XX	.280 [7.11]	.635 [16.13]	.915 [23.24]	N/A
-69	C-17-5-X	(1) ESS-XX-S	(3) DSB-XX	.180 [4.57]	.735 [18.67]	.915 [23.24]	N/A

ESW-1XX-XX-X-X-XX-XX

CONTACT STYLE  
SOLDER TAIL  
STANDARD INSERTION USE C-8-X-X  
LOW INSERTION USE C-17-X-X  
(SEE TABLE 1)

POLARIZING OPTION  
INDICATES POS  
(SEE FIG 3, SHT 2)

LOCKING LEAD OPTION  
-LL (SEE FIG 4, SHT 2)  
(N/A ON 1 OR 2  
POSITION SINGLE ROW)

ROW SPECIFICATION  
-S: SINGLE (USE SSW-50-S)  
-D: DOUBLE (USE SSW-50-D)

BODY LENGTH SPEC  
POSITIONS 01 THRU 36 (SEE FIG 1)  
(SEE NOTE 4 FOR ONE POSITION  
SINGLE ROW)  
(FOR 33 POS, SEE NOTE 6)

LEAD STYLE SPECIFICATION  
(SEE TABLE 1)

PLATING SPECIFICATION

- G: 20µ" SELECTIVE GOLD IN CONTACT AREA, 3µ" SELECTIVE GOLD ON TAIL.
- T: MATTE TIN ON ENTIRE PIN.
- (STANDARD INSERTION FORCE ONLY)
- S: 30µ" SELECTIVE GOLD IN CONTACT AREA, MATTE TIN ON TAIL.
- H: 30µ" SELECTIVE GOLD IN CONTACT AREA, 3µ" SELECTIVE GOLD ON TAIL.
- F: 3µ" SELECTIVE GOLD IN CONTACT AREA, MATTE TIN ON TAIL.
- E: 50µ" SELECTIVE GOLD IN CONTACT AREA, 3µ" SELECTIVE GOLD ON TAIL.
- L: 10µ" SELECTIVE GOLD IN CONTACT AREA, MATTE TIN ON TAIL.

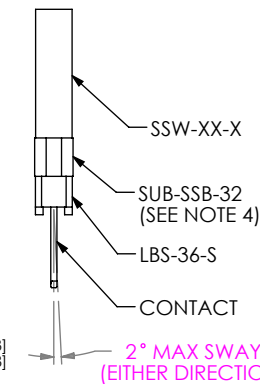
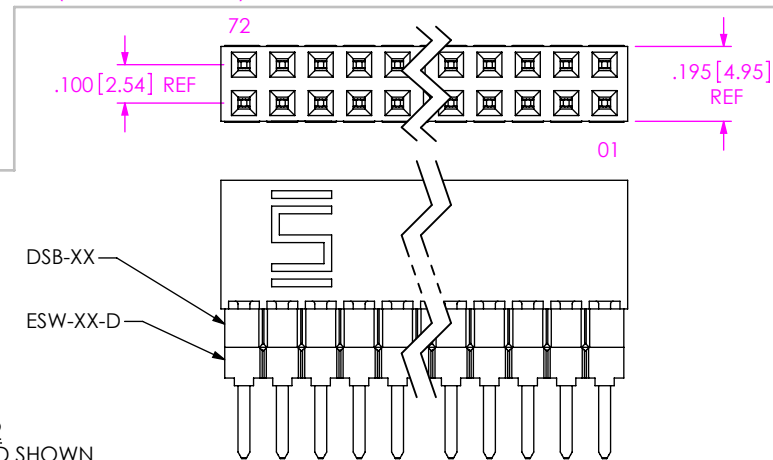


FIG 2  
ESW-1XX-XX-X-D SHOWN



UNLESS OTHERWISE SPECIFIED, DIMENSIONS ARE IN INCHES. TOLERANCES ARE:  
DECIMALS ANGLES  
.XX: ±.01 [.3]  
.XXX: ±.005 [.13]  
.XXXX: ±.0020 [.051]

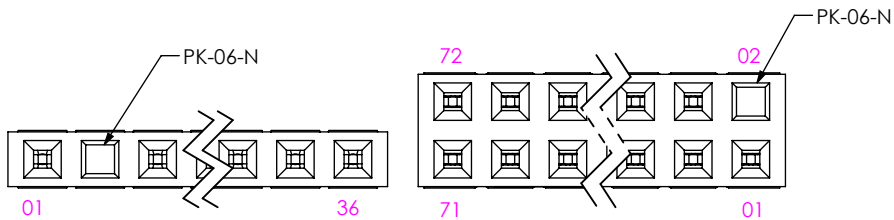
PROPRIETARY NOTE  
THIS DOCUMENT CONTAINS CONFIDENTIAL AND PROPRIETARY INFORMATION AND ALL DESIGN, MANUFACTURING, REPRODUCTION, USE, PATENT RIGHTS AND SALES RIGHTS ARE EXPRESSLY RESERVED BY SAMTEC, INC. THIS DOCUMENT SHALL NOT BE DISCLOSED, IN WHOLE OR PART, TO ANY UNAUTHORIZED PERSON OR ENTITY NOR REPRODUCED, TRANSFERRED OR INCORPORATED IN ANY OTHER PROJECT IN ANY MANNER WITHOUT THE EXPRESS WRITTEN CONSENT OF SAMTEC, INC.



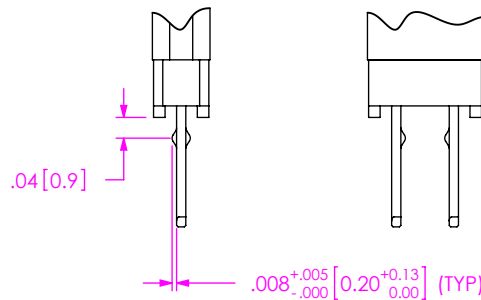
520 PARK EAST BLVD, NEW ALBANY, IN 47150  
PHONE: 812-944-6733 FAX: 812-948-5047  
e-Mail info@SAMTEC.com code 55322

MATERIAL: DO NOT SCALE DRAWING SHEET SCALE: 2:1  
SSW: LCP, UL 94 V0, COLOR: BLACK  
SSB, ESS, DSB: PBT, UL 94 V0, COLOR: BLACK  
LBS: HTN, UL 94 V0, COLOR: BLACK  
CONTACT: PHOS BRONZE

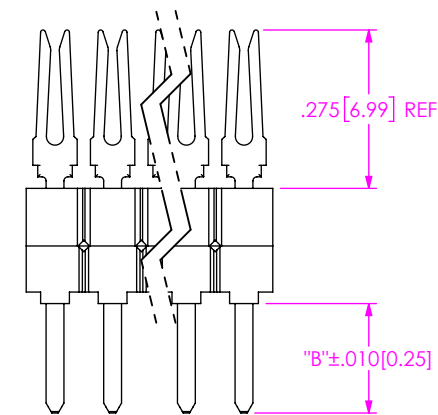
DESCRIPTION: ESW STRIP ASM.  
DWG. NO. ESW-1XX-XX-X-X-XX-XX  
BY: JORDAN 07/16/1985 SHEET 1 OF 2



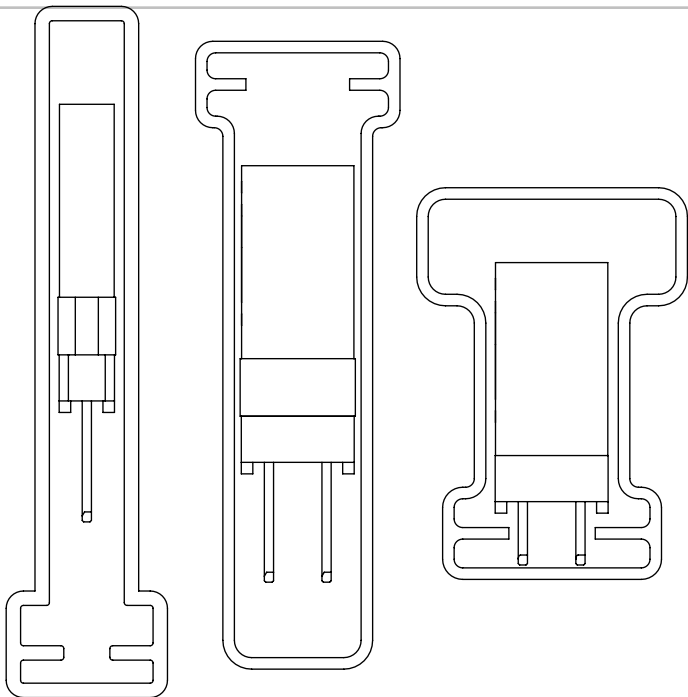
**FIG 3**  
POLARIZATION LOCATION  
INSERT PK-06-N INTO SPECIFIED POS AND BREAK OFF TAB  
(ESW-1XX-XX-X-X-02 SHOWN)  
(SAME AS FIG 1, DIFFERENT AS SHOWN)



**FIG 4**  
LOCKING LEAD OPTION  
LOCATED ON OR ABOUT THE CENTERLINE  
(N/A IN 1 OR 2 POSITION SINGLE ROW)

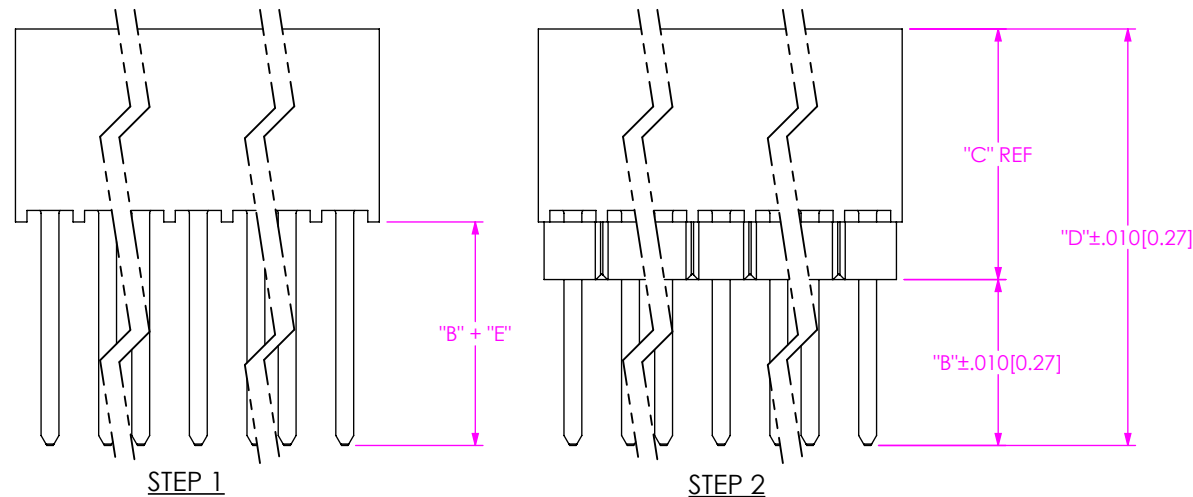


**FIG 5**  
IN PROCESS 'A'  
(LEAD STYLES -13, -14, -23, -24, -33, -34, -44, -38, -39, -48, -49, -58, -59, -69)



**FIG 7**  
TUBE VIEWS

NOTE:  
FOR -12 & -37 LEAD STYLES, TUBE PACKAGE -05 THRU -36 POSITIONS ONLY  
FOR -13, -23, -33, -38, -48 & -58 LEAD STYLES, TUBE PACKAGE -08 THRU -36 POSITIONS ONLY.  
FOR -14, -24, -34, -39, -44, -49, -59, & -69 LEAD STYLES TUBE PACKAGE -05 THRU -36 POSITIONS ONLY.



STEPS:  
1. MACHINE FILL SSW-50-D TO 36 POS.  
2. MOUNT ESW-36-D.  
3. ROTO CUT TO POS. (SEE FIG 1)

**FIG 6**  
IN PROCESS 'B'  
(LEAD STYLES -12 & -37)

TABLE 2			
LEAD STYLE	ROW	TUBE	PLUG
-12, -37	-S	PT-1-24-01-46	TP-24
-13, -14, -23, -24, -33, -34, -44, -38, -39, -48, -49, -58, -59, -69		PT-1-24-01-47	TP-09
-12, -37		PT-1-24-03-44	TP-07
-13, -14, -23, -24, -33, -34, -44, -38, -39, -48, -49, -58, -59, -69	-D	PT-1-24-02-47	TP-26

**PROPRIETARY NOTE**  
THIS DOCUMENT CONTAINS CONFIDENTIAL AND PROPRIETARY INFORMATION AND ALL DESIGN, MANUFACTURING, REPRODUCTION, USE, PATENT RIGHTS AND SALES RIGHTS ARE EXPRESSLY RESERVED BY SAMTEC, INC. THIS DOCUMENT SHALL NOT BE DISCLOSED, IN WHOLE OR PART, TO ANY UNAUTHORIZED PERSON OR ENTITY NOR REPRODUCED, TRANSFERRED OR INCORPORATED IN ANY OTHER PROJECT IN ANY MANNER WITHOUT THE EXPRESS WRITTEN CONSENT OF SAMTEC, INC.

DO NOT SCALE DRAWING

SHEET SCALE: 3:1



520 PARK EAST BLVD, NEW ALBANY, IN 47150  
PHONE: 812-944-6733 FAX: 812-948-5047  
e-Mail info@SAMTEC.com code 55322

DESCRIPTION:  
ESW STRIP ASM.

DWG. NO. ESW-1XX-XX-X-X-XX-XX

BY: JORDAN 07/16/1985 SHEET 2 OF 2