

PART NUMBER CODING

C D N

INSULATOR MATERIAL

P= PBT
 OPERATING TEMP: -65°C TO +125°C
 PROCESSING TEMP: 260°C FOR 10 SECS MAX

G= PA9T
 OPERATING TEMP: -65°C TO +150°C
 PROCESSING TEMP: 260°C FOR 120 SECS MAX

TERMINATION TYPE

NUMBER OF POSITIONS PER ROW
 (01 THRU 36)

PLATING

ALL PLATINGS HAVE .000050" NICKEL UNDERPLATE

CONTACT SURFACE	TERMINATION
B = .000010" GOLD	.000100" PURE TIN, MATTE
C = .000030" GOLD	.000100" PURE TIN, MATTE
E = .000100" PURE TIN, MATTE OVERALL	

REVISIONS				
REV.	ECO. NO	DESCRIPTION	DATE	BY
C	1062	UPDATE DWG. AND TABLES, MOVED RA TERMINATION TO PAGE 2	06/19/2006	HT
D	1062	UPDATE DWG.	3/15/2007	SB
E	2078	UPDATE TEMPERATURE TO 150°C FOR 'G' MTL, CORRECT NOTE 6 & 7, ADD NEW TERMINATION TYPE AI, AJ, AK, FF, FG, FH, FI, FJ, ZB, ZI, ZJ, ZO, ZQ, ZR, COMBINED 'P' MTL IN P/N CODING (DWG 10726, 10167 OBSOLETE)	11/12/2009	JH

TERMINATION TYPE STRAIGHT		
CODE	HEAD DIMENSION ±.008 [0.20]	TAIL DIMENSION ±.010 [0.25]
AA	.230[5.84]	.120[3.05]
AB	.230[5.84]	.230[5.84]
AC	.230[5.84]	.320[8.13]
AD	.230[5.84]	.420[10.67]
AE	.230[5.84]	.520[13.21]
AF	.230[5.84]	.620[15.75]
AG	.230[5.84]	.720[18.29]
AH	.230[5.84]	.820[20.83]
AI	.230[5.84]	.900[22.86]
AJ	.230[5.84]	1.000[25.40]
AK	.230[5.84]	.035[0.89]
FA	.318[8.08]	.120[3.05]
FB	.318[8.08]	.220[5.59]
FC	.318[8.08]	.320[8.13]
FD	.318[8.08]	.420[10.67]
FE	.318[8.08]	.520[13.21]
FF	.318[8.08]	.620[15.75]
FG	.318[8.08]	.710[18.03]
FH	.318[8.08]	.810[20.57]
FI	.318[8.08]	.910[23.11]
FJ	.318[8.08]	.050[1.27]
ZA	.120[3.05]	.120[3.05]
ZB	.120[3.05]	.095[2.41]
ZC	.120[3.05]	.260[6.60]
ZD	.120[3.05]	.610[15.49]
ZI	.520[13.21]	.110[2.79]
ZJ	.720[18.29]	.110[2.79]
ZO	.820[20.83]	.110[2.79]
ZQ	1.020[25.91]	.110[2.79]
ZR	1.220[30.99]	.110[2.79]

PART NUMBER	A		B	
	INCH	MM	INCH	MM
__C01D__N	±.008	±0.20	±.020	±0.51
__C02D__N	0.100	2.54	0.200	5.08
__C03D__N	0.200	5.08	0.300	7.62
__C04D__N	0.300	7.62	0.400	10.16
__C05D__N	0.400	10.16	0.500	12.70
__C06D__N	0.500	12.70	0.600	15.24
__C07D__N	0.600	15.24	0.700	17.78
__C08D__N	0.700	17.78	0.800	20.32
__C09D__N	0.800	20.32	0.900	22.86
__C10D__N	0.900	22.86	1.000	25.40
__C11D__N	1.000	25.40	1.100	27.94
__C12D__N	1.100	27.94	1.200	30.48
__C13D__N	1.200	30.48	1.300	33.02
__C14D__N	1.300	33.02	1.400	35.56
__C15D__N	1.400	35.56	1.500	38.10
__C16D__N	1.500	38.10	1.600	40.64
__C17D__N	1.600	40.64	1.700	43.18
__C18D__N	1.700	43.18	1.800	45.72
__C19D__N	1.800	45.72	1.900	48.26
__C20D__N	1.900	48.26	2.000	50.80
__C21D__N	2.000	50.80	2.100	53.34
__C22D__N	2.100	53.34	2.200	55.88
__C23D__N	2.200	55.88	2.300	58.42
__C24D__N	2.300	58.42	2.400	60.96
__C25D__N	2.400	60.96	2.500	63.50
__C26D__N	2.500	63.50	2.600	66.04
__C27D__N	2.600	66.04	2.700	68.58
__C28D__N	2.700	68.58	2.800	71.12
__C29D__N	2.800	71.12	2.900	73.66
__C30D__N	2.900	73.66	3.000	76.20
__C31D__N	3.000	76.20	3.100	78.74
__C32D__N	3.100	78.74	3.200	81.28
__C33D__N	3.200	81.28	3.300	83.82
__C34D__N	3.300	83.82	3.400	86.36
__C35D__N	3.400	86.36	3.500	88.90
__C36D__N	3.500	88.90	3.600	91.44

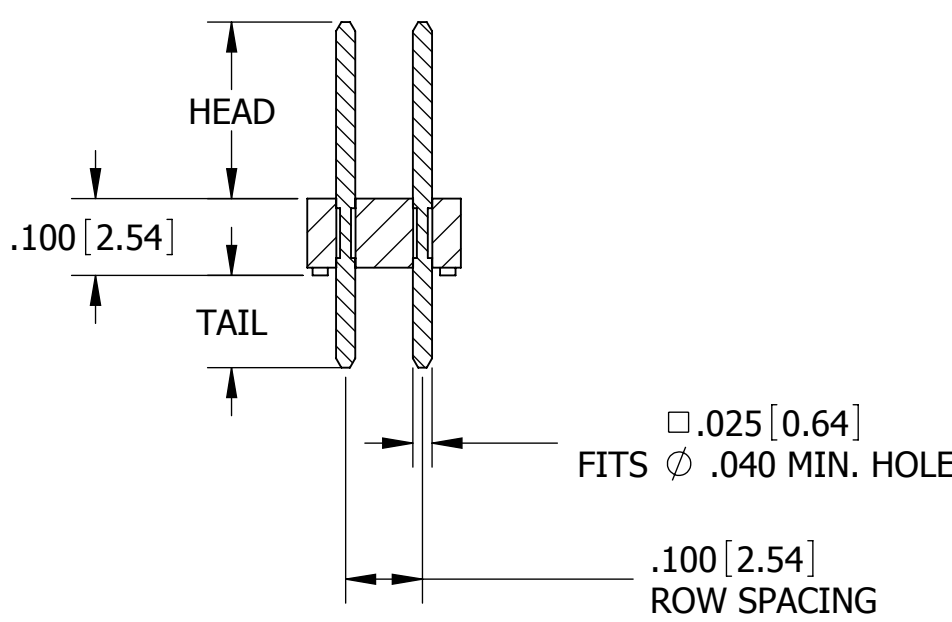
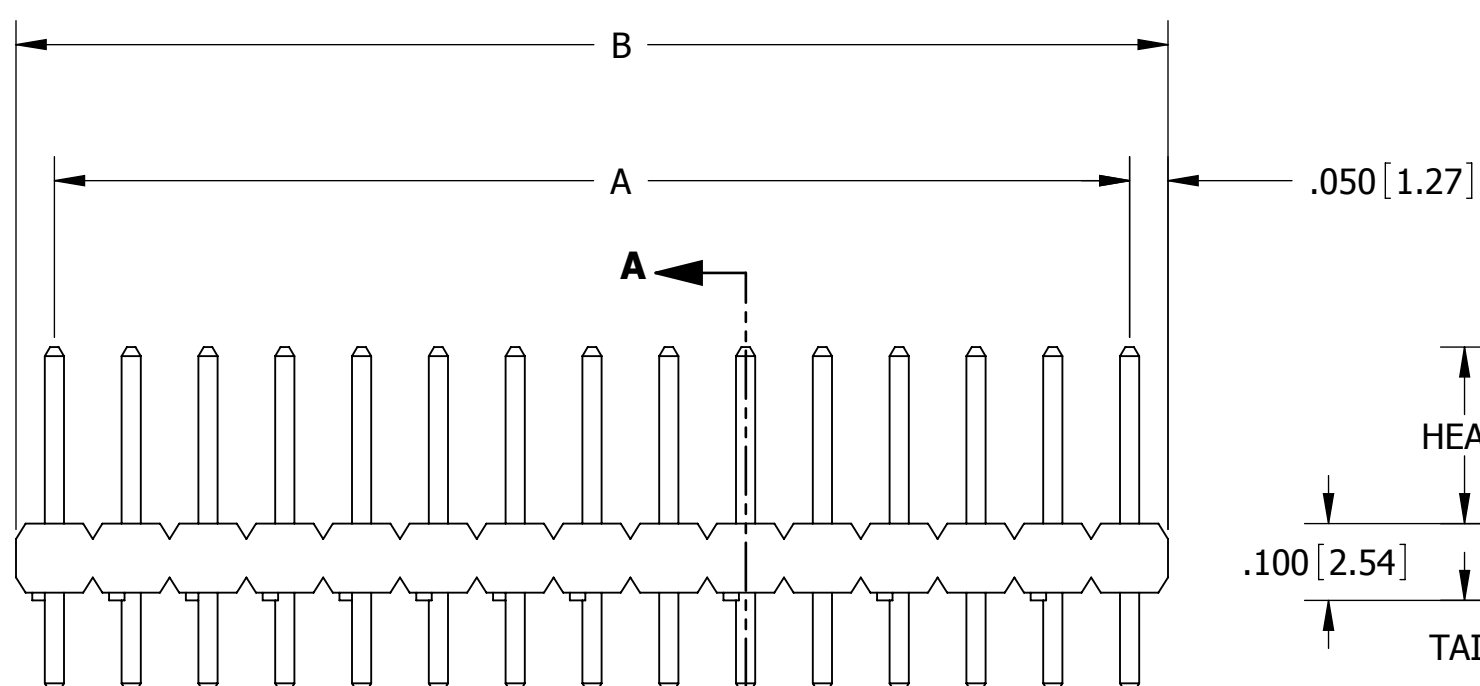
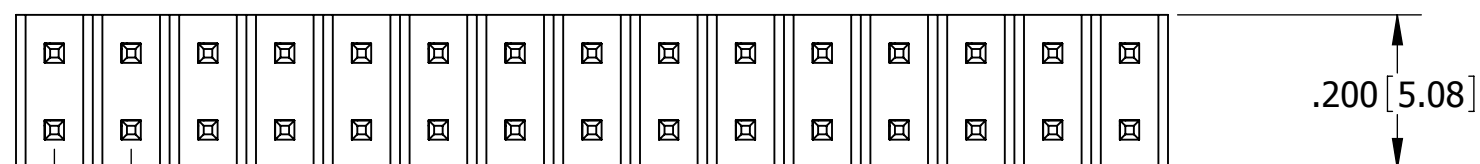

G _ C _ _ D _ _ N ; P _ C _ _ D _ _ N
STRAIGHT

- NOTES:**
- INSULATOR MATERIAL: SEE PART NUMBER CODING
 - CONTACT MATERIAL: PHOSPHOR BRONZE
 - PLATING: SEE PART NUMBER CODING
 - UL FLAMMABILITY RATING: 94V-0
 - VOLTAGE RATING: 600 VDC MINIMUM AT SEA LEVEL.
 - CURRENT RATING: 3 AMPS
 - CONTACT RESISTANCE: 30 MILLIOHMS MAX.
 - INSULATION RESISTANCE: 5000 MEGOHMS MIN.
 - MOISTURE SENSITIVITY LEVEL= 1



CUSTOMER COPY

UNLESS OTHERWISE SPECIFIED: DIMENSIONS ARE IN INCHES[MM] TOLERANCES: ANGULAR: ± 30' .XX=± .02 [.508] .XXX=± .005 [.1270] .XXXX=± .0005 [.0127] SURFACE FINISH: 63 Rq REMOVE ALL BURRS AND SHARP EDGES .010 MAX		DATE 8/2/2005	NAME AN	
THE INFORMATION HEREIN CONTAINS PROPRIETARY INFORMATION OF SULLINS ELECTRONICS AND IS NOT TO BE REPRODUCED, USED OR DISCLOSED TO OTHERS FOR ANY PURPOSE EXCEPT AS SPECIFICALLY AUTHORIZED IN WRITING BY AN OFFICER OF SULLINS ELECTRONICS.		DESCRIPTION .100" MALE HEADER, STRAIGHT PART NUMBER G _ C _ _ D _ _ N ; P _ C _ _ D _ _ N		
INTERPRET DIMENSIONS AND GEOMETRIC TOLERANCING PER: ANSI Y14.5M-1994		SIZE C	DWG. NO. C10419	REV E
SCALE: 4:1		SHEET 1 OF 1		