

DESCRIPTION

The GLF76121L is an ultra-efficient I_QSmart™ load switch with an integrated reset timer for wearables and IoT devices.

The /SRO pin offers a true reset function enabling the load switch to completely disconnect the load from the input battery after a reasonable long delay time. After the reset period, the main switch of the GLF76121L reconnect the output load to the input battery for normal operation. The GLF76121L has 11.6 second delay time and then 700 ms reset time.

The ultra-low I_Q enables direct interface to lower voltage chipset without any external circuit and maintains lower power consumption. The OFF input pin allows the GLF76121L to achieve complete shutdown with total downstream standby current of 7 nA typical. With the switch placed between a battery and system, this switch can help to significantly extend system battery life in mobile devices during shipping or periods of extended off time.

The GLF76121L help to reduce power consumption with the best in class R_{ON} and a breakthrough on state I_Q of only 3 nA typical when the switch is on.

The GLF76121L integrated 1 ms slew rate control can also enhance system reliability by mitigating bus voltage swings during switching events. Where uncontrolled switching can generate high inrush current that results in voltage droop and/or bus reset events, the GLF slew rate control specifically limits inrush current during turn-on to minimize voltage droop. The output discharge function makes output voltage off quickly during the reset period.

The GLF76121L is available in 0.97 mm x 1.47 mm x 0.55mm wafer level chip scale package (WLCSP).

FEATURES

- Ultra-Low I_{SD}: 7 nA Typ @ 3.6 VBAT
- Ultra-Low I_Q: 3 nA Typ @ 3.6 VBAT
- Low R_{ON} : 34 mΩ Typ @ 3.6 VBAT
- I_{OUT} Max : 2 A
- Supply Voltage Range: 2.5 V to 5.5 V
6 Vabs max
- Reset Delay Time (/SRO Hold Time): 11.6 s
- Reset Pulse Period GLF76121L : 700 ms
- Turn-Off Delay Time: 11.6 s
- Controlled Output Rise Time: 1 ms at 3.6 VBAT
- Integrated Output Discharge Switch When Disabled
- Operating Temperature Range: -40 to 85 °C
- HBM: 6 kV, CDM: 2 kV
- Ultra-Small: 0.97 mm x 1.47 mm WLCSP

APPLICATIONS

- Wearables
- IoT Devices
- Medical Devices

PACKAGE

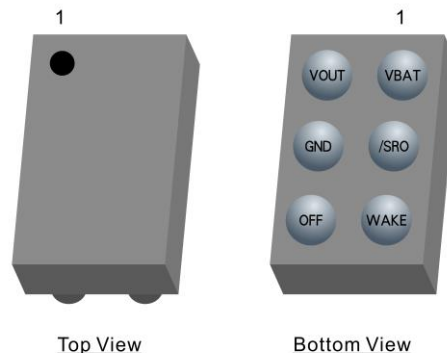

0.97 mm x 1.47 mm x 0.55 mm WLCSP

APPLICATION DIAGRAM

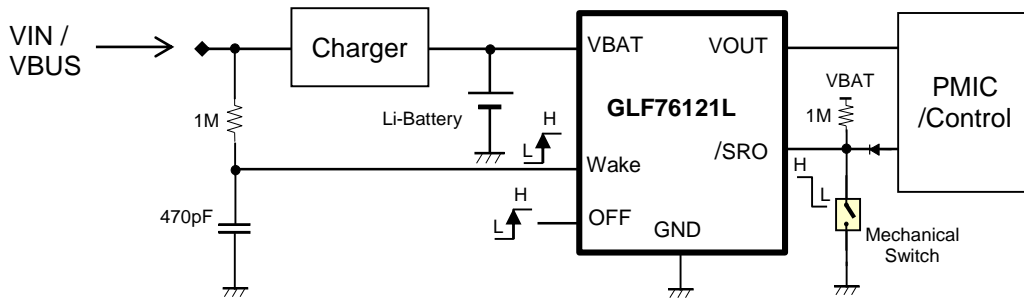

Figure 1. Typical Application with Standalone Charger IC

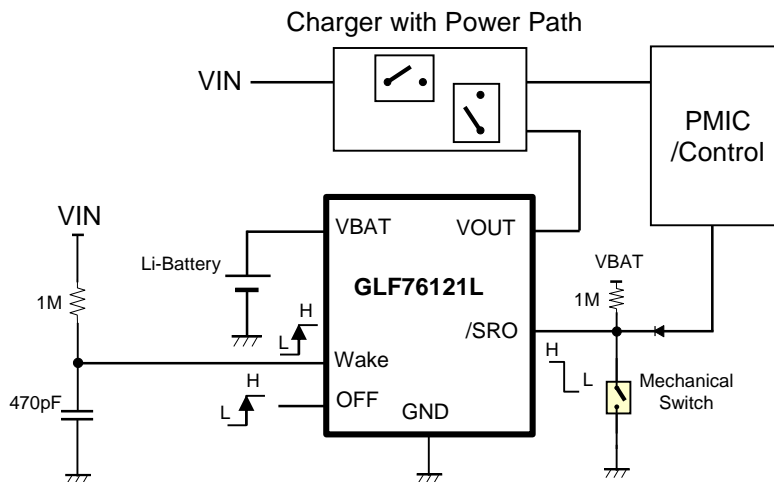

Figure 2. Typical Applications with Charger IC with Power Path and PMIC

FUNCTIONAL BLOCK DIAGRAM

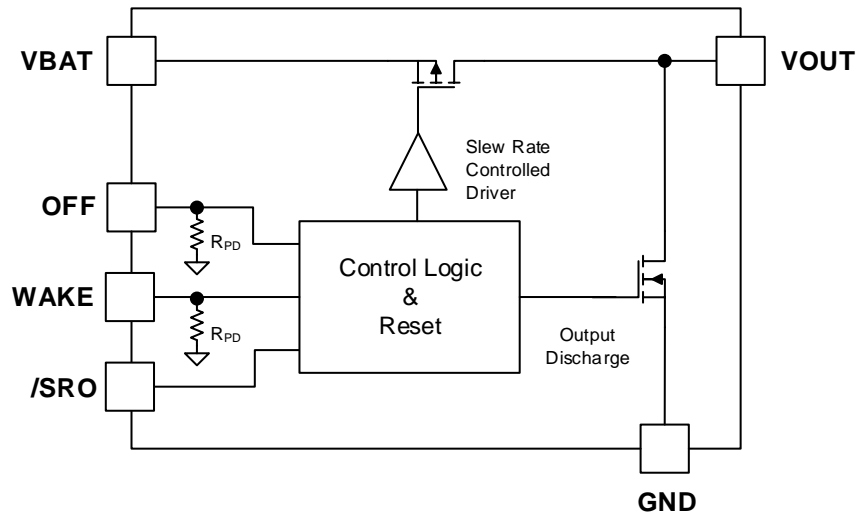
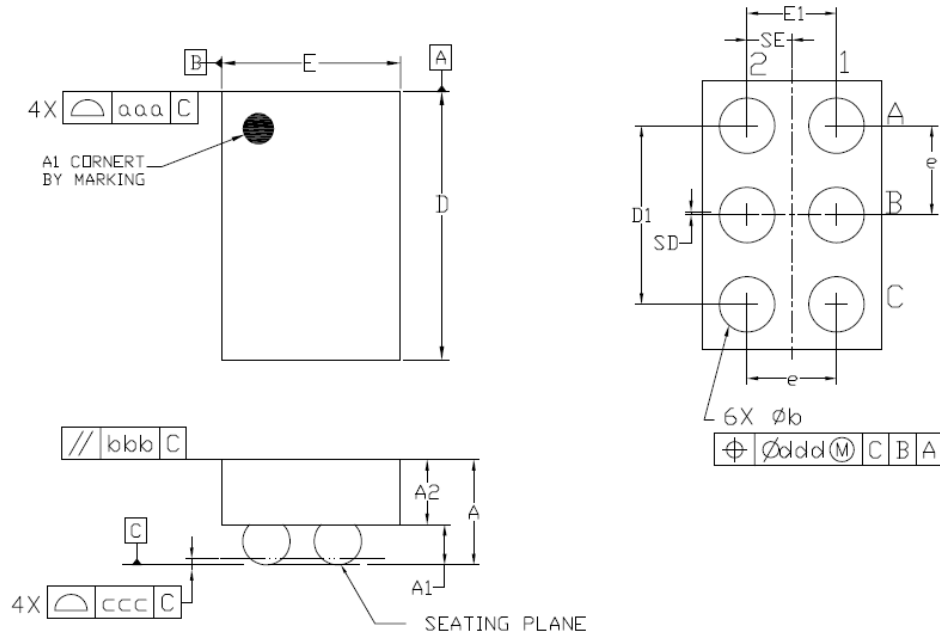

Figure 3. Functional Block Diagram

PACKAGE OUTLINE



Dimensional Ref.			
REF.	Min.	Nom.	Max.
A	0.500	0.550	0.600
A1	0.225	0.250	0.275
A2	0.275	0.300	0.325
D	1.460	1.470	1.485
E	0.960	0.970	0.985
D1	0.950	1.000	1.050
E1	0.450	0.500	0.550
b	0.260	0.310	0.360
e	0.500 BSC		
SD	0.000 BSC		
SE	0.250 BSC		
Tol. of Form&Position			
aaa	0.10		
bbb	0.10		
ccc	0.05		
ddd	0.05		

Notes

1. ALL DIMENSIONS ARE IN MILLIMETERS (ANGLES IN DEGREES).
2. DIMENSIONING AND TOLERANCING PER ANSI Y14.5M-1994.