

AD151 Datasheet

Zhuhai Jieli Technology Co.,LTD

Version: V1.0

Date: 2021.03.01

Copyright © Zhuhai Jieli Technology Co.,LTD. All rights reserved.

AD151 Features

CPU Core

- 32-bit CPU, Built-in ICACH, can be connected to Flash for expansion of code
- The main frequency is up to 120MHz

Memory

- Built-in 28Kbytes of SRAM
- 8Kbytes 2-Way Icache

Clock Source

- RC Clock frequency about 16MHz
- LRC(low power RC) clock frequency about 200KHz

Digital I/O

- Up to 28 programmable digital I/O pins
- General the IO supports pull-up(10k), pull-down(60k), strong, weak output, input and high impedance
- Up to 12 external interrupt/wake-up source(low power available, can be multiplexed to any I/O, with hardware filter)
- Input channel and Output channel, provide arbitrary IO input and output options for some modules

Digital peripherals

- Two UART Controllers(UART0/1) supports DMA and Flow Control
- Two SPI Controllers with DMA(SPI0/1)

support master mode and slave

mode, SPI0 support 4bit, SPI1 support 2bit

- One Spi Flash Controller to run code
- One SD host controller
- Three 32-bit Asynchronous Divider Timers
- One IIC Controller
- Four channel PWM output
- Infrared remote control decoder
- Watchdog
- 64-bit EFUSE

Analog Peripherals

- 0.5 watt Class-D audio amplifier output
- 14 channel 10-bit high precision ADC
- Low voltage protection
- Power on reset

Operating Conditions

- Working voltage
VBAT: 2.0v - 5.5v
HPVDD: 2.0v - 5.5v
VDDIO: 2.0v - 3.4v
- Operating Temperature: -40°C to +85°C

Package

- QFN40(5mm*5mm)

Application

- Sound Toy
- Audio player

Confidential

The information contained herein is the exclusive property of JIELI and shall not be distributed, reproduced, or disclosed in whole or in part without prior written permission of JIELI.

1、 Pin Definition

1.1 Pin Assignment

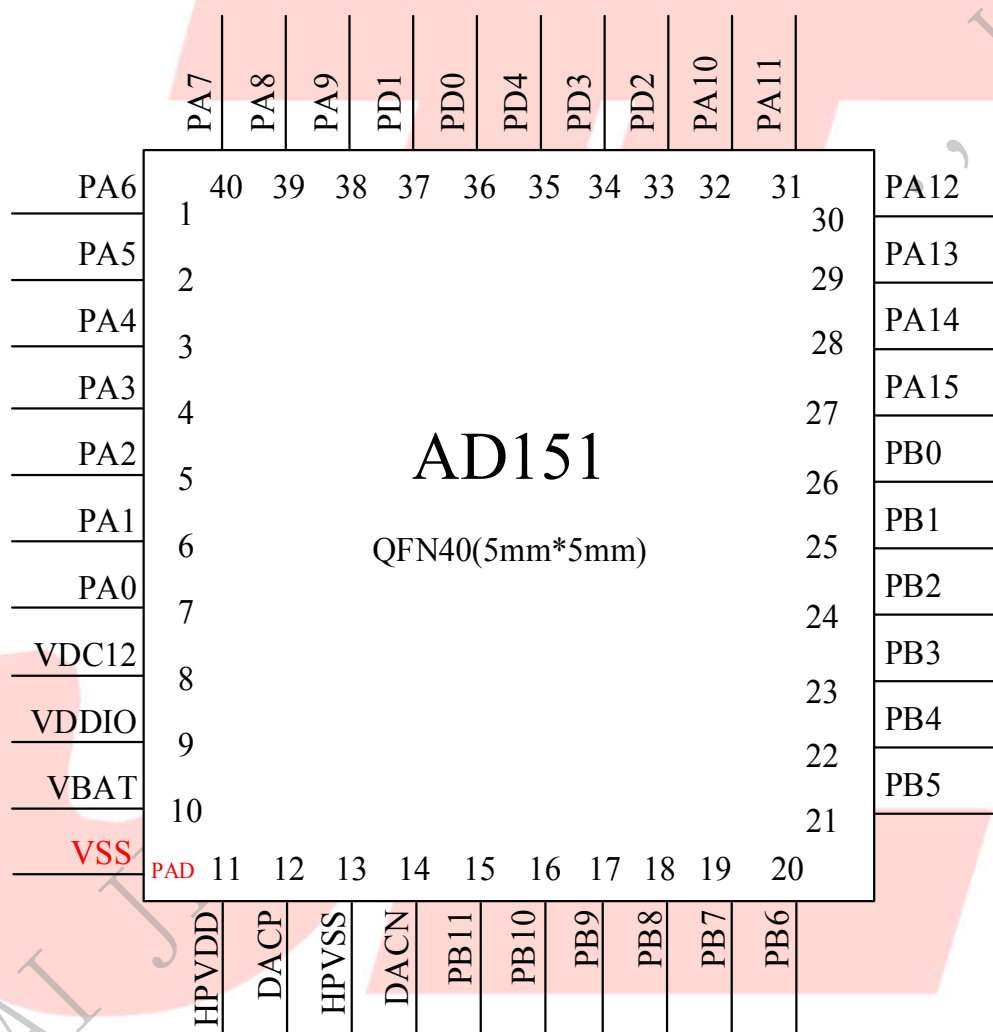

Figure 1-1 AD151_QFN40 Package Diagram

1.2 Pin Description

Table 1-1 AD151_QFN40 Pin Description

PIN NO.	Name	Type	Drive (mA)	Function	Description
1	PA6	I/O	8/64	GPIO	ADC6:ADC Input Channel 6; SPI1CLKC:SPI1 Clock(C); SD0CLKD:SD0 Clock(D); UART0TXA:Uart0 Data Out(A); I2C_SCL(C); TMR2:Timer2 Clock In; PWM0:PWM Channel0 Output;
2	PA5	I/O	8/64	GPIO	ADC5:ADC Input Channel 5; SPI0DAT3:SPI0 Data 3 UART1RXA:Uart1 Data In(A);
3	PA4	I/O	8/64	GPIO	ADC4:ADC Input Channel 4; SPI0DAT2:SPI0 Data 2; UART1TXA:Uart1 Data Out(A); LVD:Low Voltage Detect;
4	PA3	I/O	8/64	GPIO	ADC3:ADC Input Channel 3; SPI0DIB(1):SPI0 Data1 In(B); SD0DATA:SD0 Data(A); CLKOUT; PWM2L; MCAP0:Motor Timer0 Capture;
5	PA2	I/O	8/64	GPIO	ADC2:ADC Input Channel 2; SPI0DOB(0):SPI0 Data0 Out(B); SD0CMDA:SD0 Command(A); I2C_SDA(B); PWM2H;
6	PA1	I/O	8/64	GPIO	ADC1:ADC Input Channel 1; SPI0CLKB:SPI0 Clock(B); SD0CLKA:SD0 Clock(A); UART0RXB:Uart0 Data In(B); I2C_SCL(B); CAP2:Timer2 Capture;
7	PA0	I/O	8/64	GPIO (pull up)	Long Press Reset; ADC0:ADC Input Channel 0; UART0TXB:Uart0 Data Out(B);
8	VDC12	P	/		PLL Power;(Connect the bypass capacitor)

Confidential

The information contained herein is the exclusive property of JIELI and shall not be distributed, reproduced, or disclosed in whole or in part without prior written permission of JIELI.

9	VDDIO	P	/		Digital Power; (Internal linear regulator output)
10	VBAT	P	/		Battery Power Supply;
11	HPVDD	P	/		Class-D APA Power Supply;
12	DACP	O	/		Class-D APA Positive Output;
13	HPVSS	G	/		Class-D APA Ground;
14	DACN	O	/		Class-D APA Negative Output;
15	PB11	I/O	8	GPIO (High Voltage Resistance)	OSCIB:Crystal Oscillator Input(B);
16	PB10	I/O	8	GPIO (pull up) (High Voltage Resistance)	MCLR(0 effective);
17	PB9	I/O	8	GPIO (High Voltage Resistance)	SPI1DOD:SPI1 Data Out(D); UART1TRXB:Uart1 Data In/Out(B); I2C_SDA(D); CAP1:Timer1 Capture;
18	PB8	I/O	8	GPIO (High Voltage Resistance)	SPI1CLKD:SPI1 Clock(D); I2C_SCL(D); OSCIA:Crystal Oscillator Input(A);
19	PB7	I/O	8/64	GPIO	SPI1DID:SPI1 Data In(D);
20	PB6	I/O	8/64	GPIO	SD0DATC:SD0 Data(C);
21	PB5	I/O	8/64	GPIO	ADC13:ADC Input Channel 13; SD0CMDC:SD0 Command(C);
22	PB4	I/O	8/64	GPIO	ADC12:ADC Input Channel 12; SD0CLKC:SD0 Clock(C);
23	PB3	I/O	8/64	GPIO	TDM_MCLK;
24	PB2	I/O	8/64	GPIO	SPI1DIA:SPI1 Data In(A); SD0DATB:SD0 Data(B); TDM_DAT;
25	PB1	I/O	8/64	GPIO (pull down)	ADC11:ADC Input Channel 11; SPI1DOA:SPI1 Data Out(A); SD0CMDB:SD0 Command(B); I2C_SDA(A); TDM_SYN;
26	PB0	I/O	8/64	GPIO (pull down)	ADC10:ADC Input Channel 10; SPI1CLKA:SPI1 Clock(A); SD0CLKB:SD0 Clock(B); I2C_SCL(A); TDM_CLK;

Confidential

The information contained herein is the exclusive property of JIELI and shall not be distributed, reproduced, or disclosed in whole or in part without prior written permission of JIELI.

27	PA15	I/O	8/64	GPIO	ADC9:ADC Input Channel 9; SPI1DOB:SPI1 Data Out(B); MCAP3:Motor Timer3 Capture;
28	PA14	I/O	8/64	GPIO	ADC8:ADC Input Channel 8; SPI1CLKB:SPI1 Clock(B); CAP0:Timer0 Capture; MCAP2:Motor Timer2 Capture;
29	PA13	I/O	8/64	GPIO	SPI1DIB:SPI1 Data In(B); TMR1:Timer1 Clock In; MCAP1:Motor Timer1 Capture;
30	PA12	I/O	8/64	GPIO	PWM3:PWM Channel3 Output;
31	PA11	I/O	8/64	GPIO	TMR0:Timer0 Clock In; PWM2:PWM Channel2 Output;
32	PA10	I/O	8/64	GPIO	
33	PD2	I/O	8/64	GPIO (pull up)	SPI0CSA:SPI0 Chip Select(A); SFCCSA:SFC Chip Select(A);
34	PD3	I/O	8/64	GPIO	SPI0DIA(1):SPI0 Data1 In(A); SFCDIA(1):SFC Data1 In(A);
35	PD4	I/O	8/64	GPIO	Flash Power Gate;
36	PD0	I/O	8/64	GPIO	SPI0CLKA:SPI0 Clock(A); SFCCLKA:SFC Clock(A);
37	PD1	I/O	8/64	GPIO	SPI0DOA(0):SPI0 Data0 Out(A); SFCDOA(0):SFC Data0 Out(A);
38	PA9	I/O	8/64	GPIO	
39	PA8	I/O	8/64	GPIO	SPI1DIC:SPI1 Data In(C); SD0DATD:SD0 Data(D);
40	PA7	I/O	8/64	GPIO	ADC7:ADC Input Channel 7; SPI1DOC:SPI1 Data Out(C); SD0CMDD:SD0 Command(D); UART0RXA:Uart0 Data In(A); I2C_SDA(C); PWM1:PWM Channel1 Output;
PAD	VSS	G			Ground;

Confidential

The information contained herein is the exclusive property of JIELI and shall not be distributed, reproduced, or disclosed in whole or in part without prior written permission of JIELI.

2、Electrical Characteristics

2.1 Absolute Maximum Ratings

Table 2-1

Symbol	Parameter	Min	Max	Unit
Tamb	Ambient Temperature	-40	+85	°C
Tstg	Storage temperature	-65	+150	°C
VBAT	Supply Voltage	-0.3	5.5	V
HPVDD	Class D Audio Power Amplifier	-0.3	5.5	V
V _{VDDIO33}	3.3V IO Input Voltage	-0.3	3.6	V

Note : The chip can be damaged by any stress in excess of the absolute maximum ratings listed below

2.2 PMU Characteristics

Table 2-2

Symbol	Parameter	Min	Typ	Max	Unit	Test Conditions
VBAT	Voltage Input	2.0	3.7	5.5	V	—
V _{HPVDD}	Voltage Input	2.0	3.7	5.5	V	—
V _{VDDIO}	Voltage output	2.0	3.0	3.4	V	VBAT = 3.7V, 100mA loading
V _{VDC12}	Voltage output	1.05	1.2	1.4	V	VBAT=3.7V
I _{VDDIO}	Loading current	—	—	100	mA	VBAT=3.7V

2.3 IO Input/Output Electrical Logical Characteristics

Table 2-4

IO input characteristics						
Symbol	Parameter	Min	Typ	Max	Unit	Test Conditions
V _{IL}	Low-Level Input Voltage	-0.3	—	0.3* VDDIO	V	VDDIO = 3.3V
V _{IH}	High-Level Input Voltage	0.7* VDDIO	—	VDDIO+0.3	V	VDDIO = 3.3V
IO output characteristics						
V _{OL}	Low-Level Output Voltage	—	—	0.33	V	VDDIO = 3.3V
V _{OH}	High-Level Output Voltage	2.7	—	—	V	VDDIO = 3.3V

Confidential

The information contained herein is the exclusive property of JIELI and shall not be distributed, reproduced, or disclosed in whole or in part without prior written permission of JIELI.

2.4 Internal Resistor Characteristics

Table 2-5

Port	General Output	High Drive	Internal Pull-Up Resistor	Internal Pull-Down Resistor	Comment
PA0~PA15 PB0~PB7 PD0~PD4	8mA	64mA	10K	60K	1、PA0,PB10,PD2 default pull up 2、PB0 & PB1 default pull down 3、internal pull-up/pull-down resistance accuracy $\pm 20\%$
PB8~PB11	8mA	-	10K	60K	

Confidential

The information contained herein is the exclusive property of JIELI and shall not be distributed, reproduced, or disclosed in whole or in part without prior written permission of JIELI.

3、 Package Information

3.1 QFN40

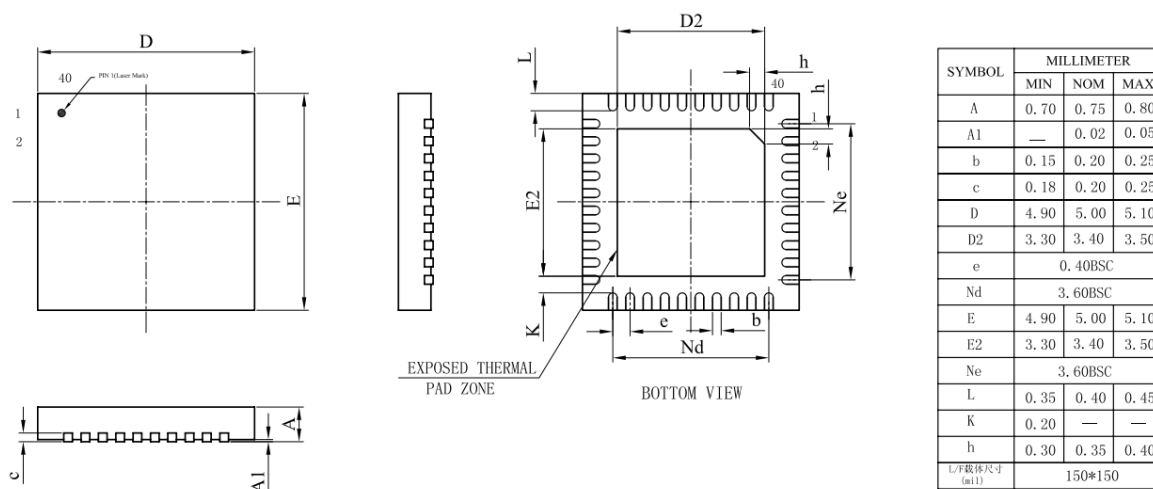

Figure 3-1. AD151_QFN40 Package

4、 Revision History

Date	Revision	Description
2021.03.01	V1.0	Initial Release

Confidential

The information contained herein is the exclusive property of JIELI and shall not be distributed, reproduced, or disclosed in whole or in part without prior written permission of JIELI.