

GaAs MMIC BI-PHASE MODULATOR, 6 - 11 GHz

Typical Applications

The HMC137 is suitable for:

- Wireless Local Loop
- LMDS & VSAT
- Pt. to Pt. Radios
- Test Equipment

Functional Diagram

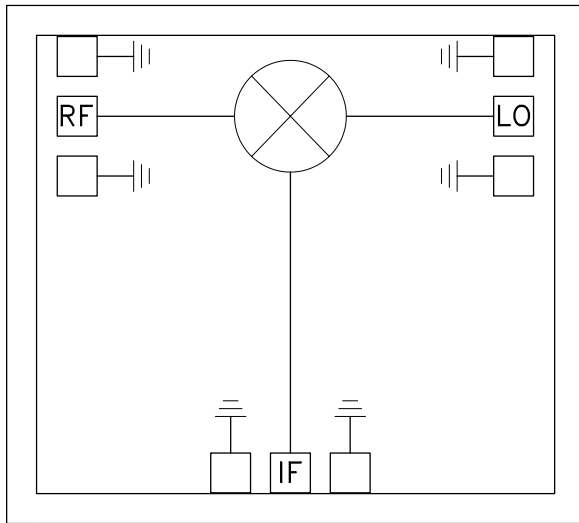

Features

- Chip Integrates Directly into MIC Designs
- 20 dB of Carrier Suppression
- Direct Modulation in the 6 - 11 GHz Band
- Functions also as a Phase Detector

General Description

The HMC137 Bi-Phase Modulator is designed to phase-modulate an RF signal into reference and 180 degree states. Device input is at the RF port and output is at the LO port. The polarity of the bias current at the control port (IF port) defines the phase states. Excellent amplitude and phase balance provided by closely matched monolithic balun and diode circuits delivers 20 dB of carrier suppression in a tiny monolithic chip. The device also functions as a demodulator or phase comparator. As a demodulator, data emerges at the control port when a modulated signal at the RF port is compared to a reference signal at the LO port. As a phase comparator, the phase angle between two signals applied to the RF and LO ports is represented by an analog voltage at the control port. Except for carrier suppression, the data presented here was measured under static conditions in which a DC bias current (nominally 5 mA) is applied to the control port.

Electrical Specifications, $T_A = +25^\circ\text{C}$, 5 mA Bias Current

Parameter	Min.	Typ.	Max.	Units
Frequency Band	6 - 11			GHz
Insertion Loss		9	11	dB
Return Loss, RF and LO Ports	2.5	3.0		dB
Amplitude Balance		0.25	0.50	dB
Phase Balance		10	15	deg
Carrier Suppression (When driven with a 1 MHz square wave, 1.4 Vp-p)	15	20		dBc
Input Power for 1 dB Compression	4	8		dBm
Third Order Intercept, Input	10	15		dBm
Second Order Intercept, Input	25	40		dBm
Bias Current (Bias current forward biases internal Schottky diodes providing approximately 0.6 V at the control port).	2	5	10	mA

For price, delivery, and to place orders, please contact Hittite Microwave Corporation:
 12 Elizabeth Drive, Chelmsford, MA 01824 Phone: 978-250-3343 Fax: 978-250-3373
 Order Online at www.hittite.com

GaAs MMIC BI-PHASE MODULATOR, 6 - 11 GHz

Insertion Loss

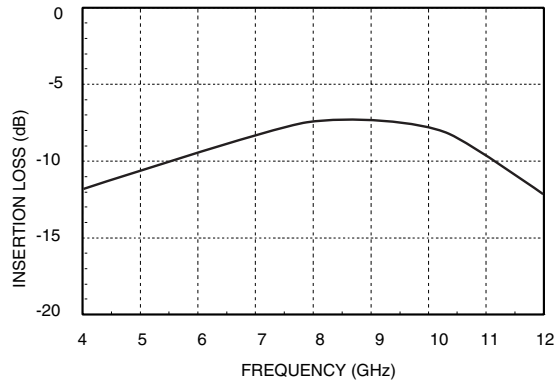

Amplitude Balance

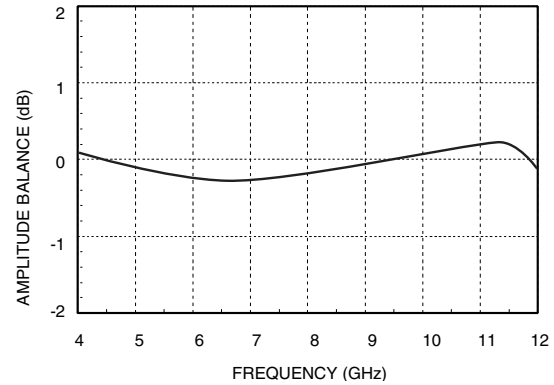

Phase Balance

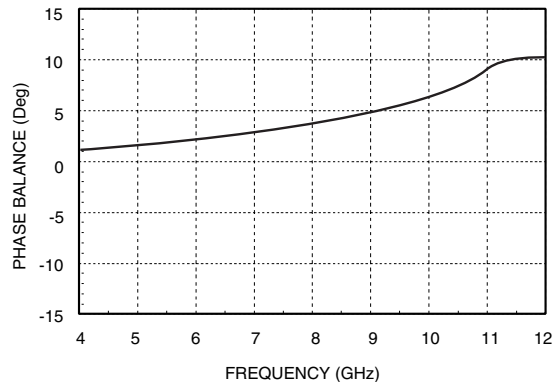

Carrier Suppression *

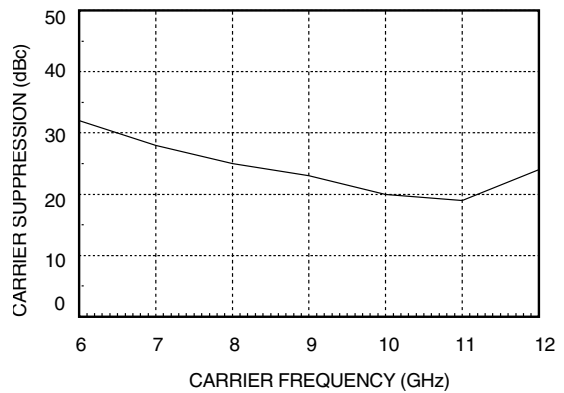

Return Loss

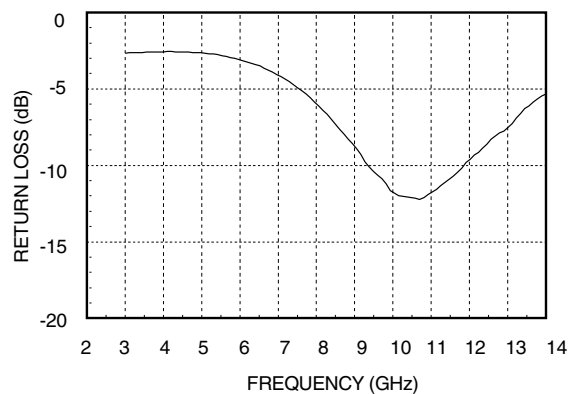

* (For 1.4 Vp-p Square Wave Modulation at 1 MHz)

GaAs MMIC BI-PHASE MODULATOR, 6 - 11 GHz

Compression vs Frequency *

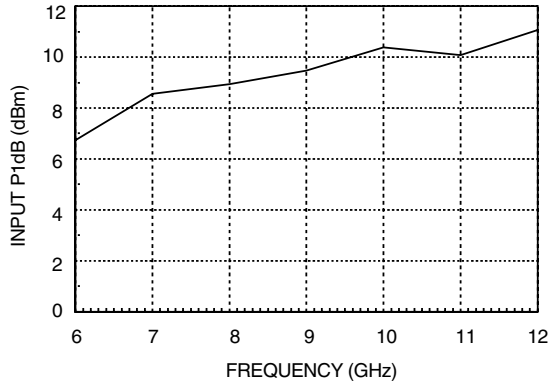

Compression vs Bias at 9 GHz

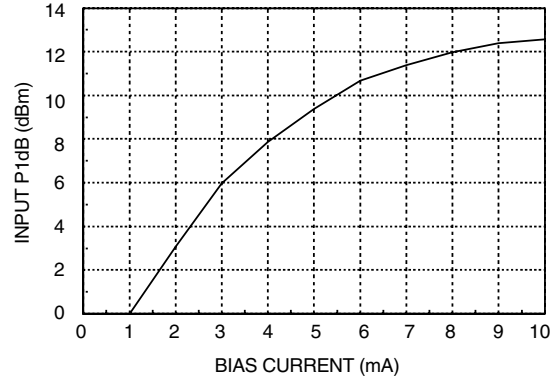

Third Order Intercept vs Frequency *

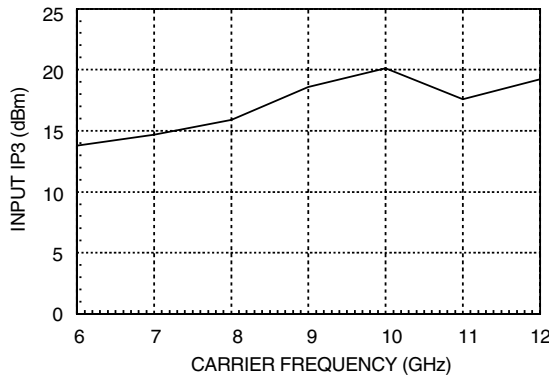

Third Order Intercept vs Bias at 9 GHz

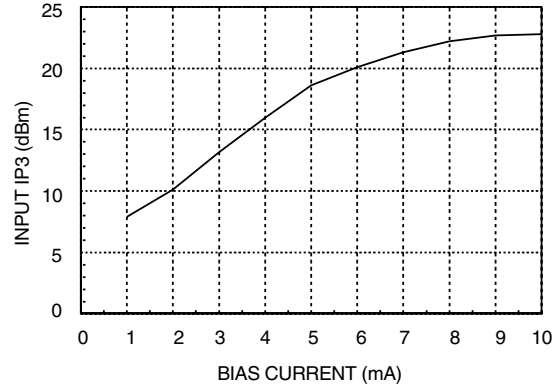

* (For 5 mA Bias Current)

GaAs MMIC BI-PHASE MODULATOR, 6 - 11 GHz

Suggested TTL Driver for a Bi-Phase Modulator

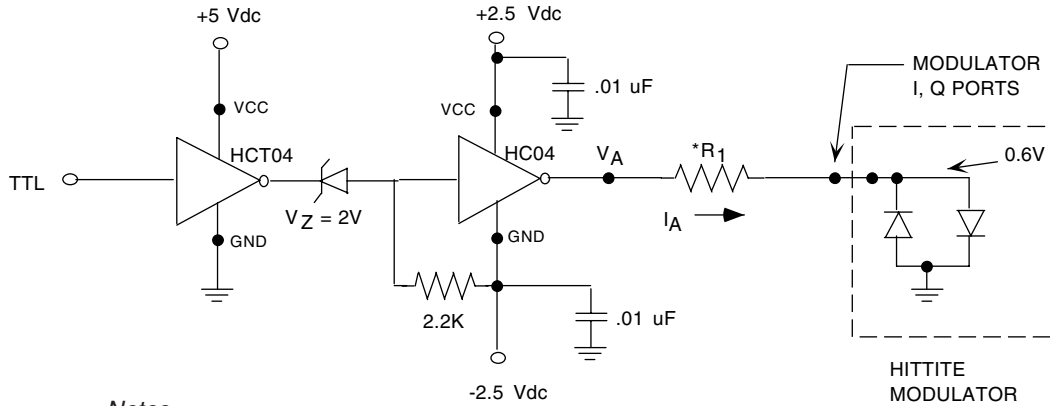

Notes

1. V_A Alternates Between $\pm 2.4 V_{dc}$
 $\pm I_A = \frac{2.4 - 0.6}{360 \text{ Ohm}} = \pm 5 \text{ mA}$

2. HCT04 and HC04 are QMOS HEX Inverters.
 $*R_1 = 300 \text{ to } 620 \pm 2\%$ Select R_1 To Supply $\pm 3 \text{ to } \pm 6 \text{ mA}$ to the IF Port.

Outline Drawing

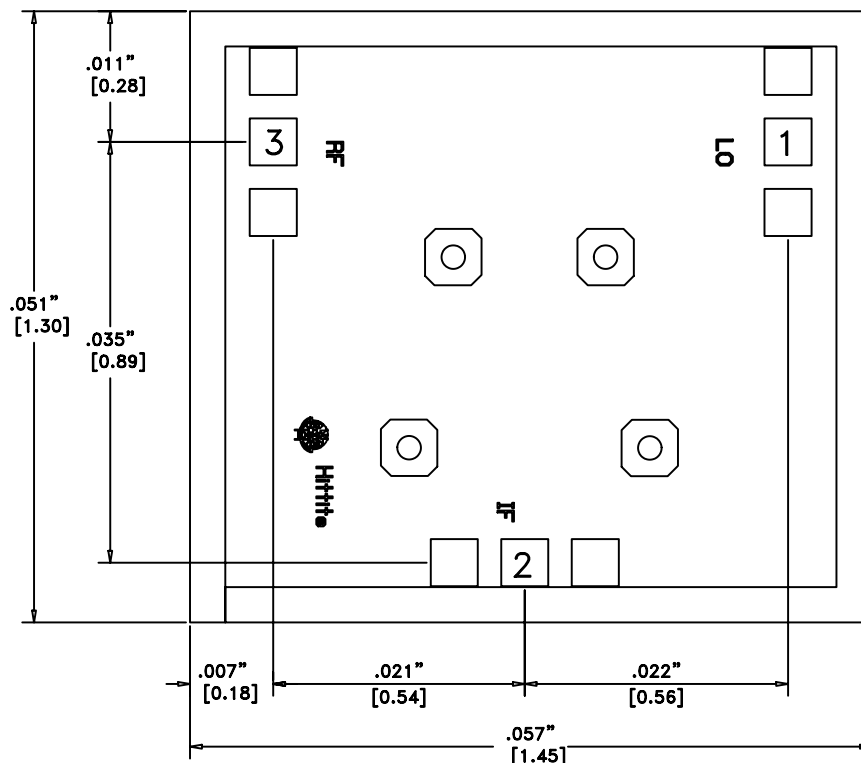

NOTES:

1. ALL DIMENSIONS ARE IN INCHES [MM].
2. TYPICAL BOND PAD IS .004" SQUARE.
3. BOND PAD SPACING IS .006" CENTER TO CENTER.
4. BACKSIDE METALIZATION: GOLD.
5. BACKSIDE METAL IS GROUND.
6. BOND PAD METALIZATION: GOLD.
7. CONNECTION NOT REQUIRED FOR UNLABELED BOND PADS.

This datasheet has been download from:

www.datasheetcatalog.com

Datasheets for electronics components.