

#### DESCRIPTION

The GLF72101 is an advanced technology fully integrated I<sub>Q</sub>Smart™ load switch device with True Reverse Current Blocking (TRCB) technology and the slew rate control of the output voltage.

The GLF72101 offers industry leading True Reverse Current Blocking (TRCB) performance, featuring an ultra-low threshold voltage. It minimizes reverse current flow in the event that the V<sub>OUT</sub> pin voltage exceeds the V<sub>IN</sub> voltage.

The GLF72101 has industry leading efficiency. It features a R<sub>ON</sub> as low as 37 mΩ typical at 5.5 V, reducing power loss during conduction. The device also features ultra-low shutdown current (I<sub>SD</sub>) to reduce power loss and battery drain in the off state. When EN is pulled low, and the output is grounded, the GLF72101 can achieve an I<sub>SD</sub> as low as 20 nA typical at 5.5 V.

The GLF72101 load switch device supports an industry leading wide input voltage range and helps to improve operating life and system robustness. Furthermore, one device can be used in multiple voltage rail applications which helps to simplify inventory management and reduces operating cost.

The GLF72101 load switch device is small utilizing a chip scale package with 6 bumps in a 0.77 mm x 0.77 mm die size and a 0.4 mm pitch.

#### FEATURES

- True Reverse Current Blocking
- Ultra-Low I<sub>Q</sub>: 0.45 uA Typ @ 5.5 V<sub>IN</sub>
- Ultra-Low I<sub>SD</sub>: 20 nA Typ @ 5.5 V<sub>IN</sub>
- Low R<sub>ON</sub> : 37mΩ Typ @ 5.5 V<sub>IN</sub>
- I<sub>OUT</sub> Max: 2 A
- Wide Input Range: 1.5 V to 5.5 V  
6 V abs max
- Controlled Rise Time: 570 us at 3.3V<sub>IN</sub>
- Internal EN Pull-Down Resistor
- Integrated Output Discharge Switch
- Ultra-Small: 0.77 mm x 0.77 mm

#### APPLICATIONS

- Mobile Devices
- Wearables
- Low Power Subsystems

#### PACKAGE

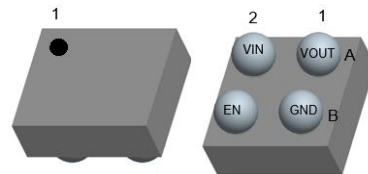

0.77 mm x 0.77 mm x 0.46 mm WLCSP

#### APPLICATION DIAGRAM

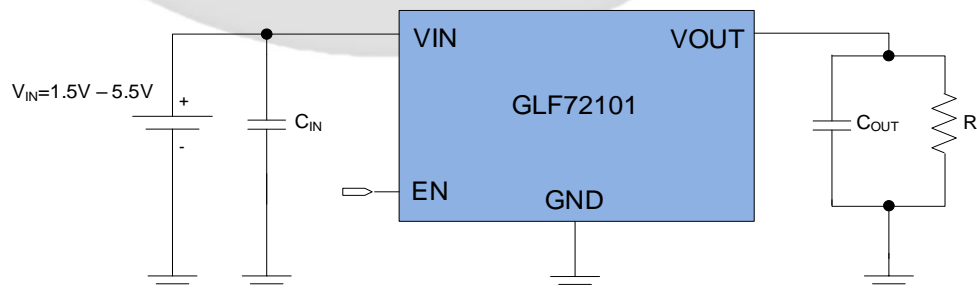

**FUNCTIONAL BLOCK DIAGRAM**

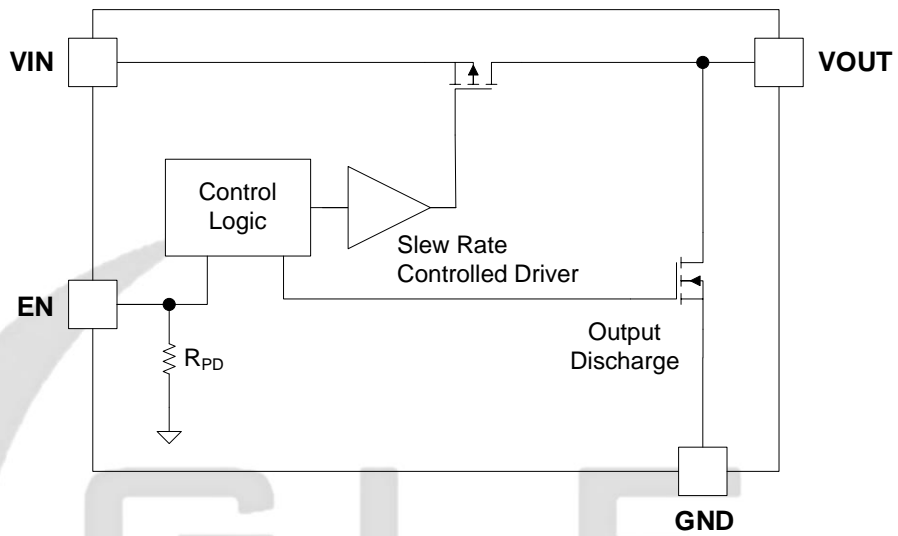
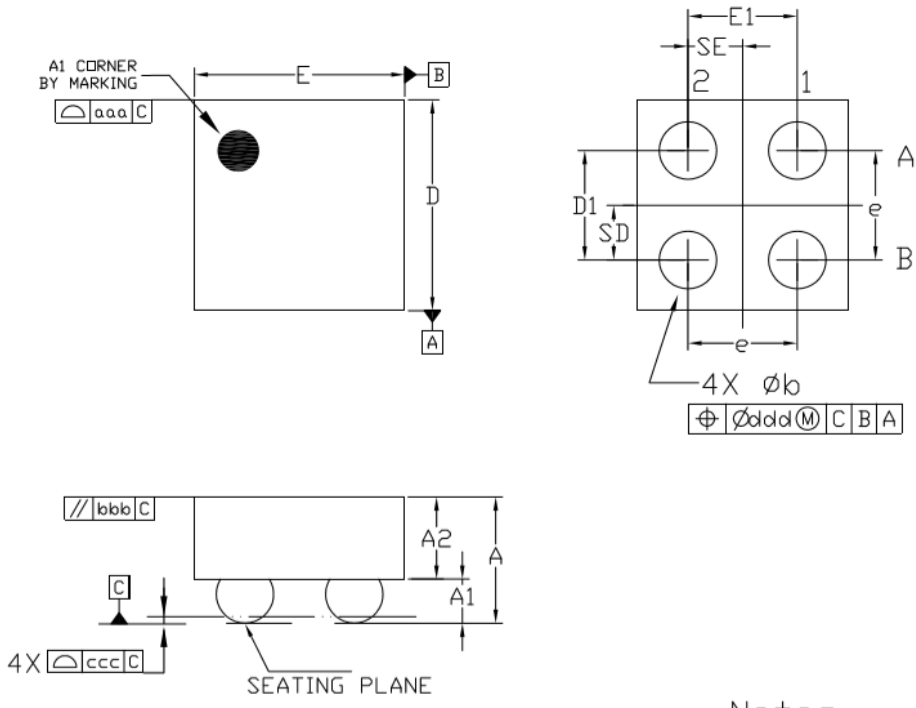

Figure 1. Functional Block Diagram

GLF  
INTEGRATED POWER

**PACKAGE OUTLINE**



Dimensional Ref.			
REF.	Min.	Nom.	Max.
A	0.410	0.460	0.510
A1	0.135	0.160	0.185
A2	0.275	0.300	0.325
D	0.755	0.770	0.785
E	0.755	0.770	0.785
D1	0.350	0.400	0.450
E1	0.350	0.400	0.450
b	0.170	0.210	0.250
e	0.400 BSC		
SD	0.200 BSC		
SE	0.200 BSC		
Tol. of Form&Position			
aaa	0.10		
bbb	0.10		
ccc	0.05		
ddd	0.05		

Notes

1. ALL DIMENSIONS ARE IN MILLIMETERS (ANGLES IN DEGREES).
2. DIMENSIONING AND TOLERANCING PER ANSI Y14.5M-1994.