

DATA SHEET

# SKY85203-11: 2.4 GHz, 802.11ac Switch/Low-Noise Amplifier Front-End

## Applications

- WiFi-enabled handsets, tablets, and mobile systems
- System-in-Package (SiP) modules for embedded systems
- 802.11n/ac smartphones and tablets

## Features

- Integrates an SP3T switch and LNA with bypass mode
- Receive gain: 14.5 dB
- Noise figure: 1.9 dB
- Transmit/Bluetooth® path loss: 0.7 dB
- Small QFN (12-pin, 2 x 2 mm) package (MSL1, 260 °C per JEDEC-J-STD-020)



Skyworks Green™ products are compliant with all applicable legislation and are halogen-free. For additional information, refer to *Skyworks Definition of Green™*, document number SQ04-0074.

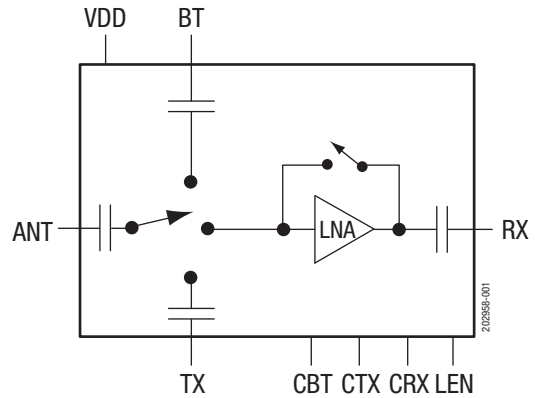

Figure 1. SKY85203-11 Block Diagram

## Description

The SKY85203-11 integrates a single-pole, triple-throw (SP3T) switch and low-noise amplifier (LNA) with a bypass mode in an ultra-compact package. The device is capable of switching between WLAN receive, WLAN transmit, and Bluetooth.

The SKY85203-11 is provided in a small Quad Flat No-Lead (QFN) 12-pin, 2 x 2 mm package. A functional block diagram is shown in Figure 1. The pin configuration and package are shown in Figure 2. Signal pin assignments and functional pin descriptions are provided in Table 1.

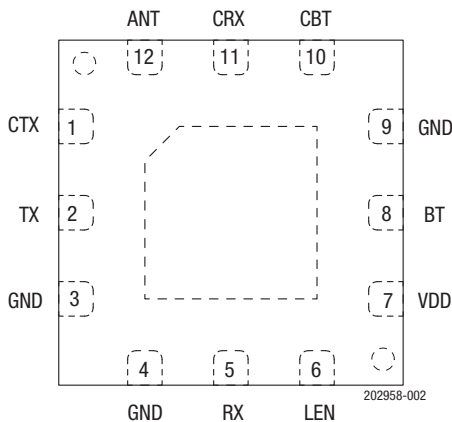

Figure 2. SKY85203-11 Pinout (Top View)

**Table 1. SKY85203-11 Signal Descriptions**

Pin	Name	Description	Pin	Name	Description
1	CTX	Control signal	7	VDD	Supply voltage
2	TX	Transmit input	8	BT	Bluetooth port
3	GND	Ground	9	GND	Ground
4	GND	Ground	10	CBT	Control signal
5	RX	LNA output	11	CRX	Control signal
6	LEN	Control signal	12	ANT	Antenna port

### Electrical and Mechanical Specifications

The absolute maximum ratings of the SKY85203-11 are provided in Table 2. The recommended operating conditions are specified

in Table 3, and electrical specifications are provided in Tables 4 to 8.

**Table 2. SKY85203-11 Absolute Maximum Ratings<sup>1</sup>**

Parameter	Symbol	Minimum	Maximum	Units
Supply voltage	V <sub>BAT</sub> , V <sub>CC</sub>	-0.3	+5.5	V
DC input on control pins	V <sub>IN</sub>	-0.3	+3.6	V
LNA input power (RXOUT terminated in 50 Ω match):	P <sub>IN</sub>			
LNA On mode			+5	dBm
Bypass mode			+20	dBm
Operating temperature	T <sub>A</sub>	-40	+85	°C
Storage temperature	T <sub>STG</sub>	-40	+140	°C

<sup>1</sup> Exposure to maximum rating conditions for extended periods may reduce device reliability. There is no damage to device with only one parameter set at the limit and all other parameters set at or below their nominal value. Exceeding any of the limits listed here may result in permanent damage to the device.

**ESD HANDLING:** *Although this device is designed to be as robust as possible, electrostatic discharge (ESD) can damage this device. This device must be protected at all times from ESD when handling or transporting. Static charges may easily produce potentials of several kilovolts on the human body or equipment, which can discharge without detection. Industry-standard ESD handling precautions should be used at all times.*

**Table 3. Recommended Operating Conditions**

Parameter	Symbol	Min	Typ	Max	Units
Supply voltage relative to ground (= 0 V)	V <sub>DD</sub>	3.0	3.6	5.0	V
Control voltage:					
High	V <sub>IH</sub>	1.6		3.6	V
Low	V <sub>IL</sub>	0		0.4	V
Control current:					
High	I <sub>IH</sub>			5	μA
Low	I <sub>IL</sub>			1	μA
Operating temperature	T <sub>A</sub>	-40	+25	+85	°C

**Table 4. SKY85203-11 Electrical Specifications: DC Characteristics<sup>1</sup>**  
**(V<sub>DD</sub> = 3.6 V, T<sub>A</sub> = +25 °C, All Unused Ports Terminated with 50 Ω, Unless Otherwise Noted)**

Parameter	Symbol	Test Condition	Min	Typ	Max	Units
Supply current	I <sub>CC</sub>	LNA enabled		11	14	mA
		Transmit/BT mode		8	12	μA
		Bypass mode		8	12	μA
		All off		8	12	μA

<sup>1</sup> Performance is guaranteed only under the conditions listed in this table.

**Table 5. SKY85203-11 Electrical Specifications: Transmit (ANT to TX) Characteristics<sup>1</sup>**  
**(V<sub>DD</sub> = 3.6 V, T<sub>A</sub> = +25 °C, All Unused Ports Terminated with 50 Ω, Unless Otherwise Noted)**

Parameter	Symbol	Test Condition	Min	Typ	Max	Units
Frequency	f		2400		2500	MHz
Insertion loss	TX <sub>IL</sub>	Insertion loss from TX input to ANT port		0.7	1.1	dB
1 dB input compression point (TX port)	IP1dB		+28	+31		dBm
Transmit input return loss (TX port)	S <sub>11</sub>		-15	-20		dB
Output return loss (ANT port)	S <sub>22</sub>		-12	-18		dB
ANT to RX isolation, TX (loopback) mode				42		dB
TX to ANT isolation @ 3.8 GHz: All other modes	RX <sub>iso</sub>		20	27		dB

<sup>1</sup> Performance is guaranteed only under the conditions listed in this table.

**Table 6. SKY85203-11 Electrical Specifications: Transmit (ANT to BT) Characteristics<sup>1</sup>**  
**(V<sub>DD</sub> = 3.6 V, T<sub>A</sub> = +25 °C, All Unused Ports Terminated with 50 Ω, Unless Otherwise Noted)**

Parameter	Symbol	Test Condition	Min	Typ	Max	Units
Frequency	f		2400		2500	MHz
Insertion loss	BT <sub>IL</sub>	Insertion loss from BT input to ANT port		0.7	1.1	dB
1 dB input compression point (BT port)	IP1dB		+28	+31		dBm
Transmit input return loss (BT port)	S <sub>11</sub>		-15	-20		dB
Output return loss (ANT port)	S <sub>22</sub>		-15	-20		dB
BT to ANT isolation @ 3.8 GHz: All other modes	BT <sub>iso</sub>		20	25		dB

<sup>1</sup> Performance is guaranteed only under the conditions listed in this table.

**Table 7. SKY85203-11 Electrical Specifications: Receive (ANT to RX Port) Characteristics<sup>1</sup>**  
**(V<sub>DD</sub> = 3.6 V, T<sub>A</sub> = +25 °C, All Unused Ports Terminated with 50 Ω, Unless Otherwise Noted)**

Parameter	Symbol	Test Condition	Min	Typ	Max	Units
Frequency	f		2400		2500	MHz
Small signal gain	S21	LNA enabled Bypass mode	12 -9	14.5 -6.5	16 -5	dB dB
LNA gain step	Gain_STEP	Gain step change between LNA normal and LNA bypass modes	19	21	23	dB
Gain flatness		Over 20 MHz Full band			±0.25 ±0.50	dB dB
Noise figure	NF	LNA enabled Bypass mode		1.9 6.5	2.2	dB dB
Third order input intercept point	IIP3	LNA enabled Bypass mode	+1 +24	+3 +27		dBm dBm
Receive input return loss	S11			-19	-14	dB
Receive output return loss	S22			-14	-8	dB
Receive to transmit (or BT) switching time	t <sub>RX</sub> - t <sub>X(BT)</sub>	10% to 90%			500	ns
Transmit (or BT) to receive switching time	t <sub>TX(BT)</sub> - t <sub>RX</sub>	10% to 90%			500	ns
LNA turn-on time	t <sub>OFF</sub> - t <sub>ON</sub>	10% to 90%			500	ns
LNA turn-off time	t <sub>ON</sub> - t <sub>OFF</sub>	90% to 10%			200	ns
RX to ANT isolation @ 3.8 GHz: Non-RX modes	RX <sub>iso</sub>		20	25		dB

<sup>1</sup> Performance is guaranteed only under the conditions listed in this table.

**Table 8. SKY85203-11 Control Logic**

Mode	CBT (Pin 10)	CTX (Pin 1)	LEN (Pin 6)	CRX (Pin 11)
All off	0	0	0	0
WLAN receive LNA	0	0	1	1
WLAN receive bypass	0	0	0	1
Bluetooth	1	0	0	0
WLAN transmit	0	1	0	0

**Note:** “0” = 0 V to +0.4 V. “1” = +1.6 V to +3.6 V. Any state other than described in this table places the switch into an undefined state. An undefined state will not damage the device.

## Evaluation Board Description

The SKY85203-11 Evaluation Board is used to test the performance of the SKY85203-11 LNA FEM. An Evaluation Board schematic diagram is provided in Figure 3. A photograph of the Evaluation Board is shown in Figure 4.

## Evaluation Board Setup Procedure

1. Connect the system ground to pin 19 of connector J9.
2. Apply 3.3 V to VDD pin 17 of connector J9.
3. Refer to the Control Logic Table in Table 8 to set the device in the desired mode of operation. Set CRX, CTX, CBT, and LEN to appropriate VIL and VIH voltages, as specified in Table 3.
4. Transmit performance is monitored by applying an RF signal to the connector J4 (TX) and measuring the output power at the antenna port connector J3 (ANT).
5. Monitor the receive performance in either high gain or bypass mode by applying an RF signal to the antenna port connector J3 (ANT) and measuring the output power at the receive port connector J2 (RX).
6. Monitor the Bluetooth performance by applying an RF signal to the antenna port connector J1 (BT) and measuring the output power at the receive port connector J3 (ANT).

## Evaluation Board Losses

The total track losses from the RF connectors of the Evaluation Board to the flip chip die bumps of the SKY85203-11 are:

ANT: 0.22 dB

TX: 0.22 dB

RX: 0.22 dB

BT: 0.36 dB

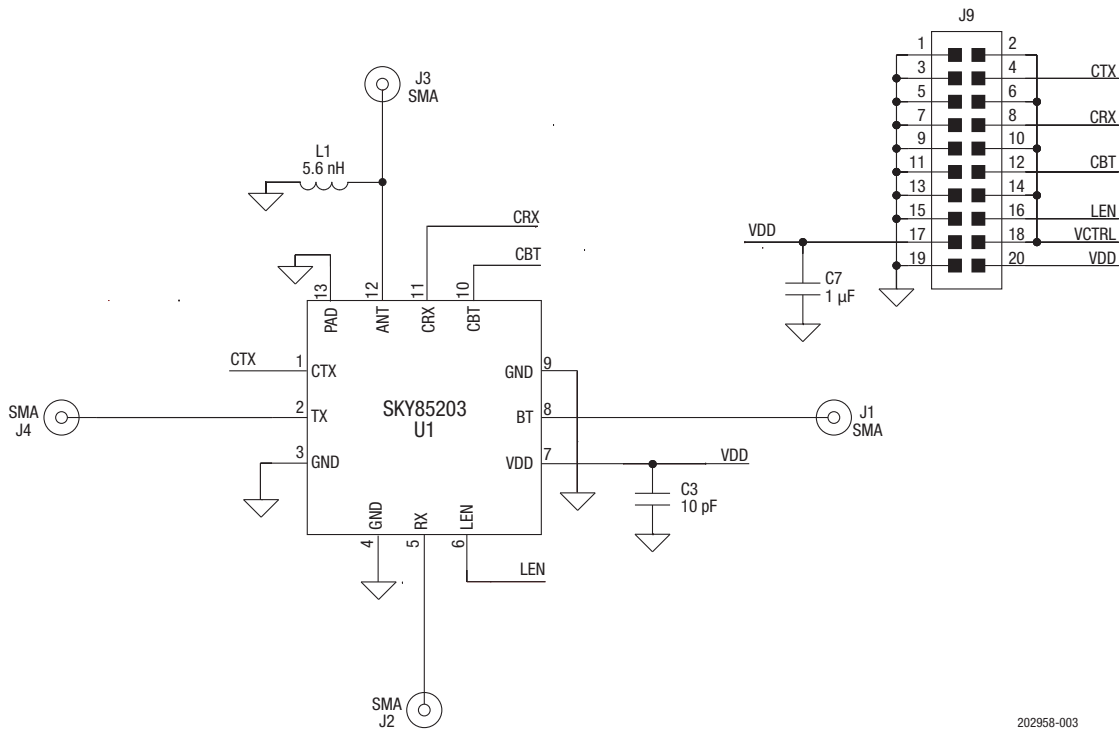

202958-003

Figure 3. SKY85203-11 Evaluation Board Schematic

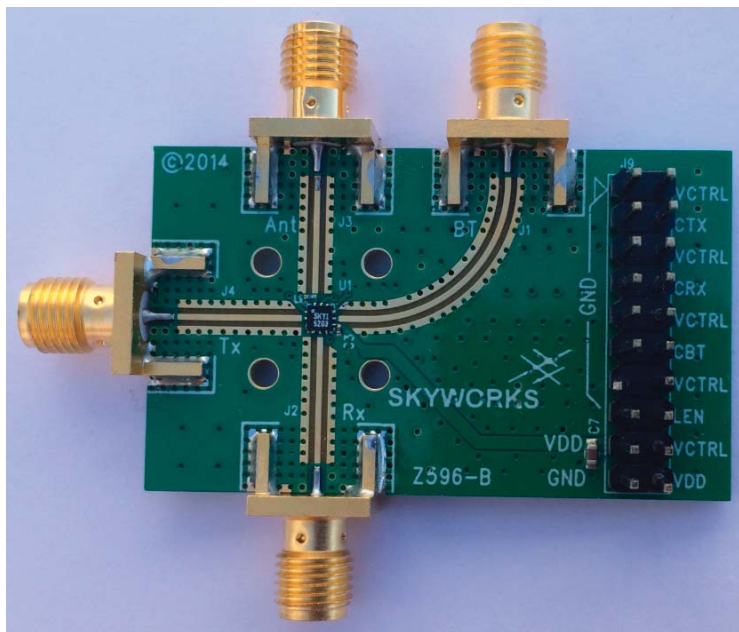

202958-004

Figure 4. SKY85203-11 Evaluation Board

## Package Dimensions

The PCB layout footprint for the SKY85203-11 is provided in Figure 5. Typical part markings are shown in Figure 6. Package dimensions are shown in Figure 7, and tape and reel dimensions are provided in Figure 8.

## Package and Handling Information

Instructions on the shipping container label regarding exposure to moisture after the container seal is broken must be followed. Otherwise, problems related to moisture absorption may occur when the part is subjected to high temperature during solder assembly.

The SKY85203-11 is rated to Moisture Sensitivity Level 1 (MSL1) at 260 °C. It can be used for lead or lead-free soldering. For additional information, refer to the Skyworks Application Note, *Solder Reflow Information*, document number 200164.

Care must be taken when attaching this product, whether it is done manually or in a production solder reflow environment. Production quantities of this product are shipped in a standard tape and reel format.

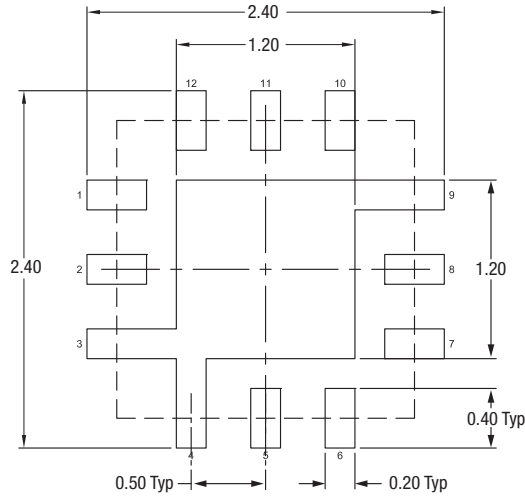

Board Metal

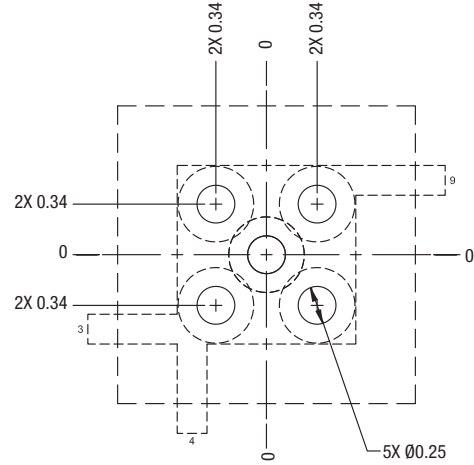

Via Pattern  
(Note 4)

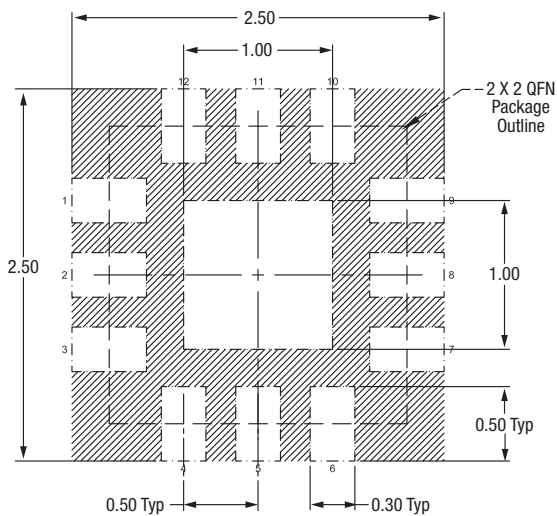

Solder Mask Pattern

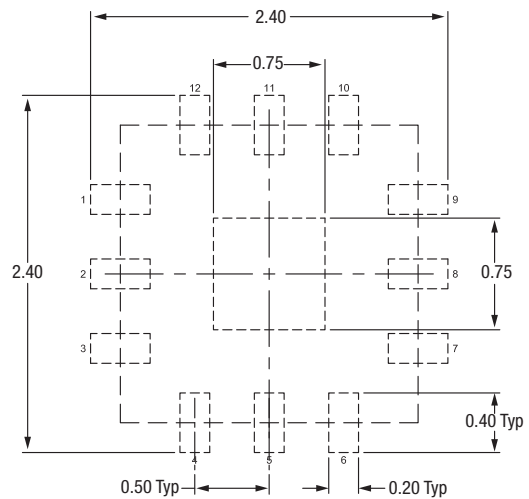

Stencil Pattern  
(Note 5)

56% Solder Coverage  
on Center Pad

Notes:

1. All dimensions are in millimeters.
2. Dimensions and tolerances per ASME Y14.5M-1994.
3. Unless specified, dimensions are symmetrical about center lines.
4. Via hole recommendations:  
Cu via wall plating: 0.025 mm minimum  
Should be filled with conductive paste and plated over.
5. Stencil recommendations: 0.10 mm stencil thickness.  
Laser cut apertures, trapezoidal walls and rounded corners offer better paste release.

202958-005

Figure 5. SKY85203-11 PCB Layout Footprint



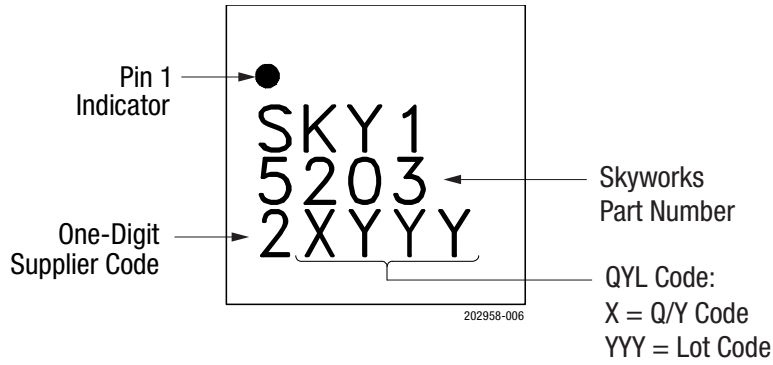

Figure 6. Typical Part Marking

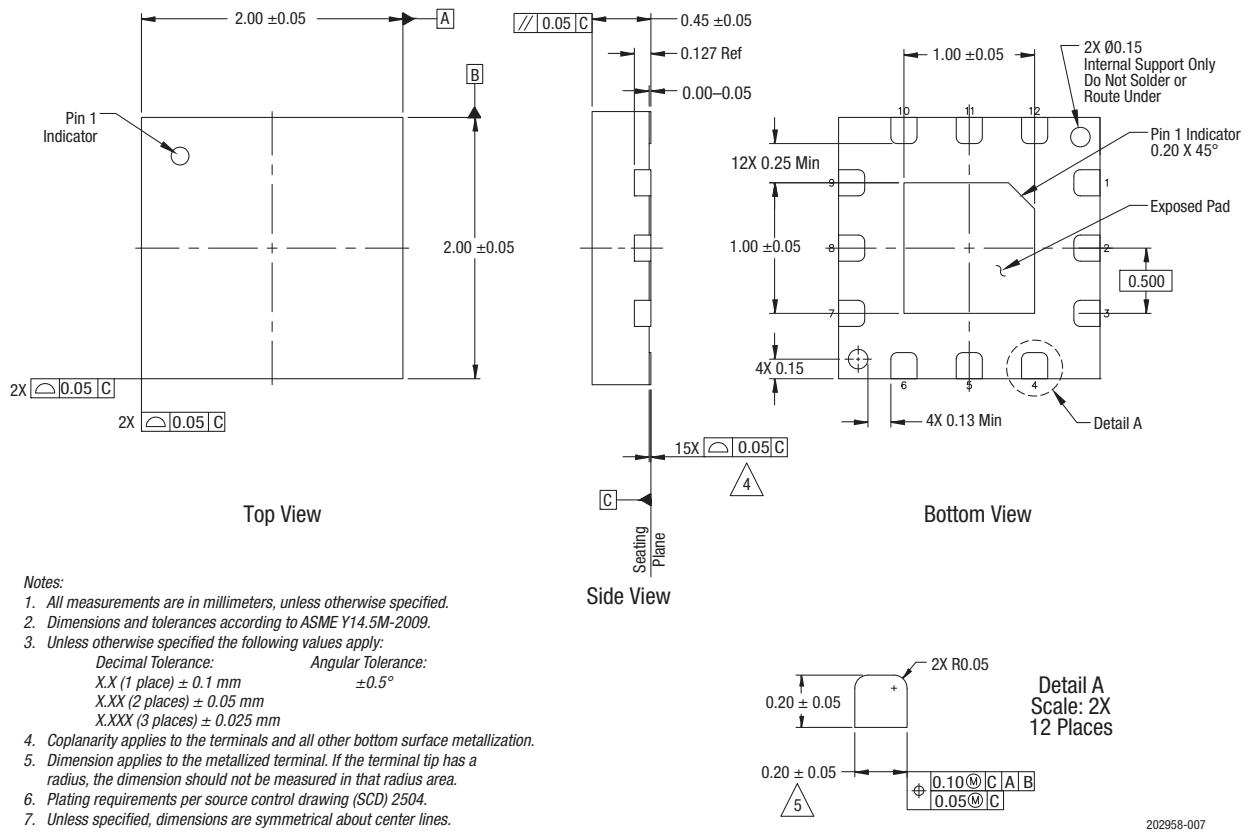
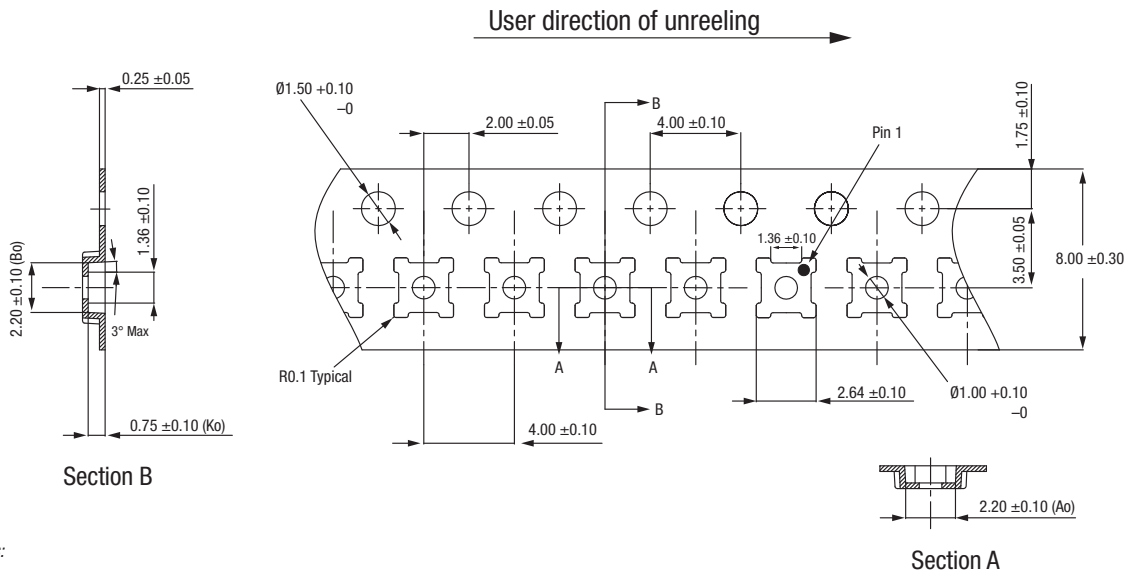

Figure 7. SKY85203-11 Package Dimensions



Notes:

1. Carrier tape: black conductive polystyrene.
2. Cover tape material: transparent conductive.
3. 10-sprocket hole pitch cumulative tolerance on tape:  $\pm 0.20$  mm.
4. All dimensions are in millimeters.

Tolerances:

General:  
 $\pm 0.2$

Angles:  
 $\pm 1^\circ$

202958-008

**Figure 8. SKY85203-11 Tape and Reel Dimensions**

## Ordering Information

Part Number	Product Description	Evaluation Board Part Number
SKY85203-11	2.4 GHz, 802.11ac Switch/Low-Noise Amplifier Front-End	SKY85203-11EK1

Copyright © 2013-2018 Skyworks Solutions, Inc. All Rights Reserved.

Information in this document is provided in connection with Skyworks Solutions, Inc. ("Skyworks") products or services. These materials, including the information contained herein, are provided by Skyworks as a service to its customers and may be used for informational purposes only by the customer. Skyworks assumes no responsibility for errors or omissions in these materials or the information contained herein. Skyworks may change its documentation, products, services, specifications or product descriptions at any time, without notice. Skyworks makes no commitment to update the materials or information and shall have no responsibility whatsoever for conflicts, incompatibilities, or other difficulties arising from any future changes.

No license, whether express, implied, by estoppel or otherwise, is granted to any intellectual property rights by this document. Skyworks assumes no liability for any materials, products or information provided hereunder, including the sale, distribution, reproduction or use of Skyworks products, information or materials, except as may be provided in Skyworks Terms and Conditions of Sale.

THE MATERIALS, PRODUCTS AND INFORMATION ARE PROVIDED "AS IS" WITHOUT WARRANTY OF ANY KIND, WHETHER EXPRESS, IMPLIED, STATUTORY, OR OTHERWISE, INCLUDING FITNESS FOR A PARTICULAR PURPOSE OR USE, MERCHANTABILITY, PERFORMANCE, QUALITY OR NON-INFRINGEMENT OF ANY INTELLECTUAL PROPERTY RIGHT; ALL SUCH WARRANTIES ARE HEREBY EXPRESSLY DISCLAIMED. SKYWORKS DOES NOT WARRANT THE ACCURACY OR COMPLETENESS OF THE INFORMATION, TEXT, GRAPHICS OR OTHER ITEMS CONTAINED WITHIN THESE MATERIALS. SKYWORKS SHALL NOT BE LIABLE FOR ANY DAMAGES, INCLUDING BUT NOT LIMITED TO ANY SPECIAL, INDIRECT, INCIDENTAL, STATUTORY, OR CONSEQUENTIAL DAMAGES, INCLUDING WITHOUT LIMITATION, LOST REVENUES OR LOST PROFITS THAT MAY RESULT FROM THE USE OF THE MATERIALS OR INFORMATION, WHETHER OR NOT THE RECIPIENT OF MATERIALS HAS BEEN ADVISED OF THE POSSIBILITY OF SUCH DAMAGE.

Skyworks products are not intended for use in medical, lifesaving or life-sustaining applications, or other equipment in which the failure of the Skyworks products could lead to personal injury, death, physical or environmental damage. Skyworks customers using or selling Skyworks products for use in such applications do so at their own risk and agree to fully indemnify Skyworks for any damages resulting from such improper use or sale.

Customers are responsible for their products and applications using Skyworks products, which may deviate from published specifications as a result of design defects, errors, or operation of products outside of published parameters or design specifications. Customers should include design and operating safeguards to minimize these and other risks. Skyworks assumes no liability for applications assistance, customer product design, or damage to any equipment resulting from the use of Skyworks products outside of stated published specifications or parameters.

Skyworks and the Skyworks symbol are trademarks or registered trademarks of Skyworks Solutions, Inc. or its subsidiaries in the United States and other countries. Third-party brands and names are for identification purposes only, and are the property of their respective owners. Additional information, including relevant terms and conditions, posted at [www.skyworksinc.com](http://www.skyworksinc.com), are incorporated by reference.