



# PFC thyristor module

**Series/Type: TSM-LC200**

The following products presented in this data sheet are being withdrawn.

Ordering Code	Substitute Product	Date of Withdrawal	Deadline Last Orders	Last Shipments
B44066T0200E402		2021-05-07	2021-08-13	2021-11-13

Please contact your nearest TDK sales office if you need support in selecting a suitable substitute. The addresses of our worldwide sales network are presented at [www.tdk-electronics.tdk.com/sales](http://www.tdk-electronics.tdk.com/sales).

### Characteristics

- Fast electronically controlled self observing thyristor switch
- For capacitive loads up to 200 kvar
- Suitable for designing dynamic PFC-systems in 380 and 400 V grids
- Micro-processor controlled alignment to tuned or detuned capacitor branches (up to 14 %) for optimized switching behaviour
- No system perturbation due to switching operations (transients)
- Switching without delay
- Maintenance-free
- Long useful service life
- No noise emission during switching operation
- Compact module ready for connection

### Features

- Easy installation: mechanical assembly directly on a mounting plate
- Self check after turn-on of main voltage
- Optimized switching behaviour to the connected load (tuned/detuned) via the internal processor
- Storage of optimized parameters for optimum switching behaviour
- Mounting position: Upright; minimum 150 mm space on top and below
- Display and control via LED display
  - Operation
  - Faults
  - Activation
- Permanent self-monitoring
  - Temperature
  - Voltage
  - Operating state



**Technical data and specifications**

Dimensions	250 x 480 x 160 mm (w x h x d)
Weight	11.5 kg
Rated voltage	380 ... 400 V
Maximum voltage	
- in conventional PFC-systems (without reactors)	440 V
- in detuned PFC-systems (7 % detuning)	440 V (no upwards tolerance permitted)
- in detuned PFC-systems (14 % detuning)	400 V
Auxiliary supply	230 V AC
Frequency	50/60 Hz
Switching capability	Max. 200 kvar at 400 V
Activation	10...24 V DC (approx. 20 mA) via terminal clamp, internally electrically isolated
Switching time	Approx. 5 ms
Reset time	Depending on degree of detuning and dimension of discharge resistor
Display	2 status LEDs per phase: operation/fault and triggering signal
Power circuit	Direct connection 4 pole via busbar (cable lug max. 185 mm <sup>2</sup> , D = 12 mm), connection from the top
Power dissipation	$P_D$ (in W) = 2,0 x I (in A) ; at 400 V/200 kvar approx. 580 W thermal
Fuses (mandatory for protection of components)	3 x electronic fuse „superfast“ NH2 AC 690V, characteristic gRL 125 kvar: 315 A (e.g. SIBA Art.Nr. 20.212.20.315) 150 kvar: 350 A (e.g. SIBA Art.Nr. 20.212.20.350) 200 kvar: 450 A (e.g. SIBA Art.Nr. 20 212. 20.450)
Ambient operating temperature at nominal load	-10 °C ... +55 °C

Connection diagram: three-phase load (standard)

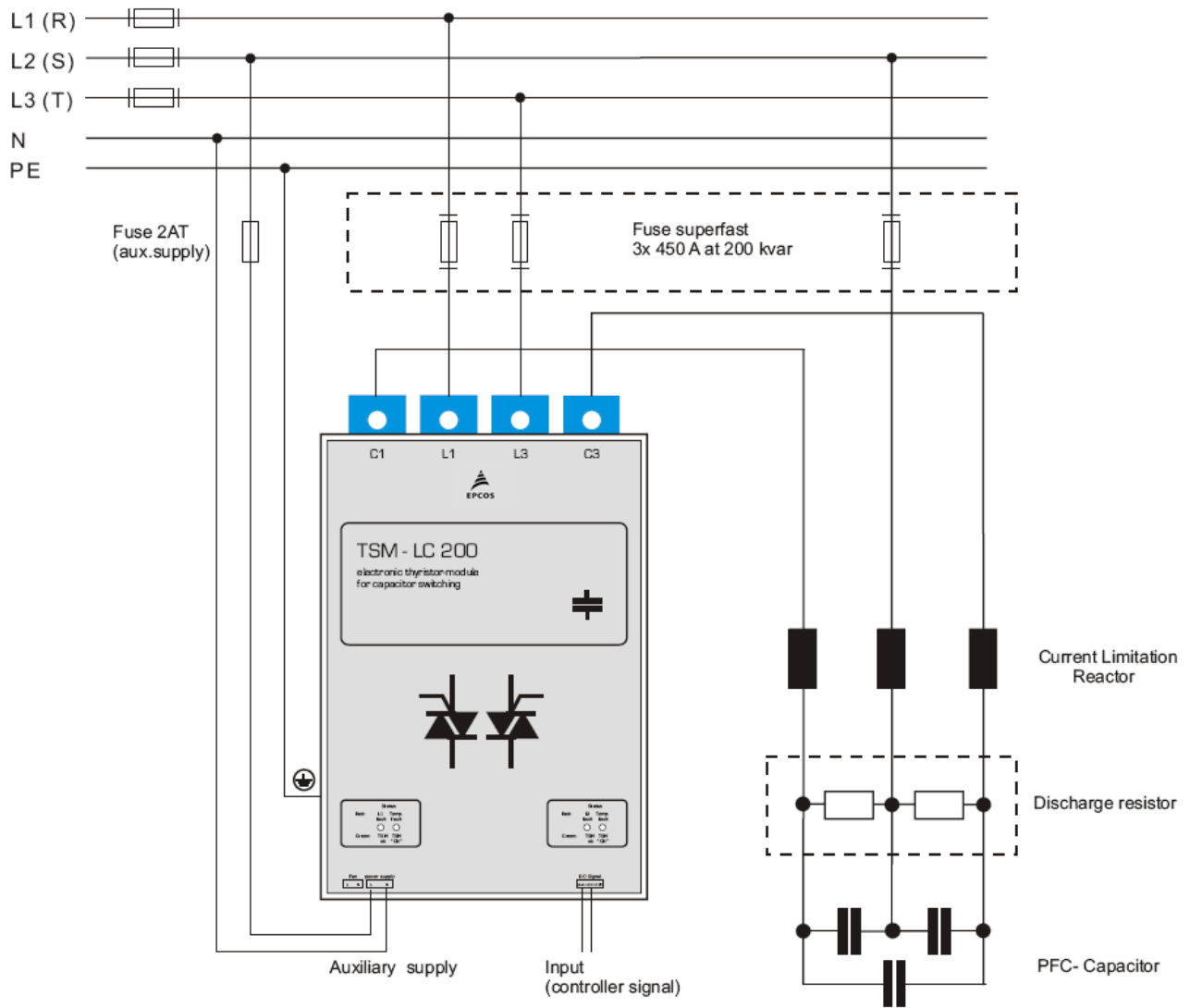

Dimensional drawing

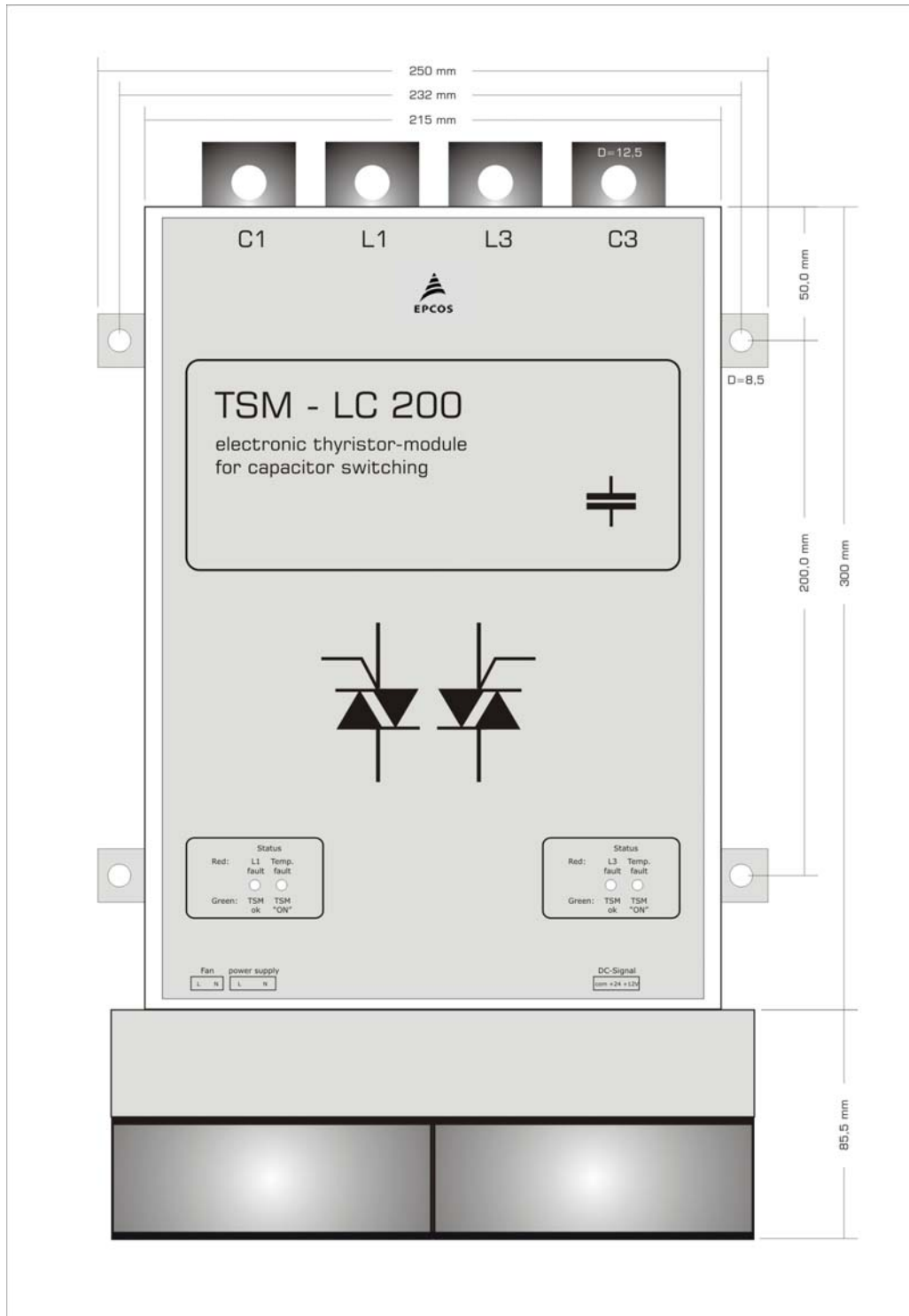

## Cautions and Warnings

### General

- Thyristor modules TSM series may only be used for the purpose they have been designed for.
- Thyristor modules TSM series may only be used in combination with appropriate pre-switched grid separator device.
- Thyristor modules have to be projected in such a way that in case of any failure no uncontrolled high current and voltages may occur.
- The devices in operation have to be protected against moisture and dust, sufficient cooling has to be assured.

### Attention

Due to the switching principle of the thyristor module the power capacitors are permanently loaded to the peak value of the grid voltage (DC voltage) even when switched off. Therefore following rules have to be obeyed in any case:

- For standard PFC-systems (without reactors) power capacitors of 440 V nominal voltage have to be used; for detuned systems PFC capacitors of 525 V nominal voltage have to be used.
- Due to the high voltage (2 x peak value of nominal voltage) that occurs, the discharge resistors of the power capacitors have to be replaced by special types (accessory EW22).
- In dynamic systems with TSM modules no fast discharge reactors may be used (reactor = DC-wise short circuit).
- For standard PFC-systems 2 current limiting reactors are mandatory per thyristor module (accessory BD100).
- Thyristor modules in general have to be protected by superfast electronic fuses. Principles for dimensioning have to be considered. Fuses in the system have to be marked.
- Due to the special switching, the PFC capacitors are fully loaded even when the particular step has been switched off. Protection against contact has to be guaranteed. Warning signals in the systems are required.
- Even in switched off state no electrical isolation is achieved for electronic switches. Therefore parts of the systems may not be touched after switching off the complete system before the capacitors have been completely discharged.

FAILURE TO FOLLOW CAUTIONS MAY RESULT, WORST CASE, IN PREMATURE FAILURES OR PHYSICAL INJURY.

### Note

For detailed information about PFC capacitors and cautions, refer to the latest version of EPCOS PFC Product Profile.

## Important notes

The following applies to all products named in this publication:

1. Some parts of this publication contain **statements about the suitability of our products for certain areas of application**. These statements are based on our knowledge of typical requirements that are often placed on our products in the areas of application concerned. We nevertheless expressly point out **that such statements cannot be regarded as binding statements about the suitability of our products for a particular customer application**. As a rule we are either unfamiliar with individual customer applications or less familiar with them than the customers themselves. For these reasons, it is always ultimately incumbent on the customer to check and decide whether a product with the properties described in the product specification is suitable for use in a particular customer application.
2. We also point out that **in individual cases, a malfunction of electronic components or failure before the end of their usual service life cannot be completely ruled out in the current state of the art, even if they are operated as specified**. In customer applications requiring a very high level of operational safety and especially in customer applications in which the malfunction or failure of an electronic component could endanger human life or health (e.g. in accident prevention or life-saving systems), it must therefore be ensured by means of suitable design of the customer application or other action taken by the customer (e.g. installation of protective circuitry or redundancy) that no injury or damage is sustained by third parties in the event of malfunction or failure of an electronic component.
3. **The warnings, cautions and product-specific notes must be observed.**
4. In order to satisfy certain technical requirements, **some of the products described in this publication may contain substances subject to restrictions in certain jurisdictions (e.g. because they are classed as hazardous)**. Useful information on this will be found in our Material Data Sheets on the Internet ([www.tdk-electronics.tdk.com/material](http://www.tdk-electronics.tdk.com/material)). Should you have any more detailed questions, please contact our sales offices.
5. We constantly strive to improve our products. Consequently, **the products described in this publication may change from time to time**. The same is true of the corresponding product specifications. Please check therefore to what extent product descriptions and specifications contained in this publication are still applicable before or when you place an order.  
  
We also **reserve the right to discontinue production and delivery of products**. Consequently, we cannot guarantee that all products named in this publication will always be available. The aforementioned does not apply in the case of individual agreements deviating from the foregoing for customer-specific products.
6. Unless otherwise agreed in individual contracts, **all orders are subject to our General Terms and Conditions of Supply**.
7. **Our manufacturing sites serving the automotive business apply the IATF 16949 standard**. The IATF certifications confirm our compliance with requirements regarding the quality management system in the automotive industry. Referring to customer requirements and customer specific requirements ("CSR") TDK always has and will continue to have the policy of respecting individual agreements. Even if IATF 16949 may appear to support the acceptance of unilateral requirements, we hereby like to emphasize that **only requirements mutually agreed upon can and will be implemented in our Quality Management System**. For clarification purposes we like to point out that obligations from IATF 16949 shall only become legally binding if individually agreed upon.
8. The trade names EPCOS, CeraCharge, CeraDiode, CeraLink, CeraPad, CeraPlas, CSMP, CTVS, DeltaCap, DigiSiMic, ExoCore, FilterCap, FormFit, LeaXield, MiniBlue, MiniCell, MKD, MKK, MotorCap, PCC, PhaseCap, PhaseCube, PhaseMod, PhiCap, PowerHap, PQSine, PQvar, SIFERRIT, SIFI, SIKOREL, SilverCap, SIMDAD, SiMic, SIMID, SineFormer, SIOV, ThermoFuse, WindCap are **trademarks registered or pending** in Europe and in other countries. Further information will be found on the Internet at [www.tdk-electronics.tdk.com/trademarks](http://www.tdk-electronics.tdk.com/trademarks).

Release 2018-10