

## TO-92 Plastic-Encapsulate MOSFETs

### 2N7002K N-channel MOSFET

$V_{(BR)DSS}$	$R_{DS(on)MAX}$	$I_D$
60V	5Ω@10V	340mA
	5.3Ω@4.5V	

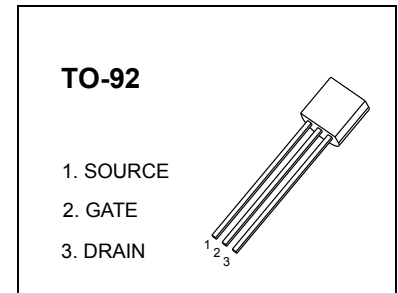

#### FEATURE

- High density cell design for Low  $R_{DS(on)}$
- Voltage controlled small signal switch
- Rugged and reliable
- High saturation current capability
- ESD protected

#### APPLICATION

- Load Switch for Portable Devices
- DC/DC Converter

#### MARKING

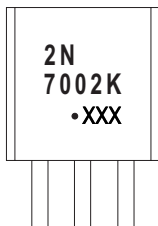

Pin1

2N7002K= Device code  
 Solid dot = Green molding compound device,  
 if none, the normal device  
 XXX= Code

#### Equivalent circuit

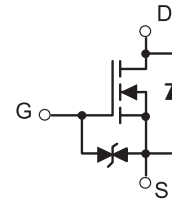

#### ORDERING INFORMATION

Part Number	Package	Packing Method	Pack Quantity
2N7002K	TO-92	Bulk	1000pcs/Bag
2N7002K-TA	TO-92	Tape	2000pcs/Box

#### MOSFET MAXIMUM RATINGS ( $T_a = 25^\circ\text{C}$ unless otherwise noted)

Symbol	Parameter	Value	Unit
$V_{DS}$	Drain-Source voltage	60	V
$V_{GS}$	Gate-Source voltage	±20	V
$I_D$	Drain Current	340	mA
$P_D$	Power Dissipation	0.625	W
$T_J$	Junction Temperature	150	°C
$T_{stg}$	Storage Temperature	-55~+150	°C
$R_{\theta JA}$	Thermal Resistance from Junction to Ambient	200	°C/W

## MOSFET ELECTRICAL CHARACTERISTICS

$T_a=25\text{ }^\circ\text{C}$  unless otherwise specified

Parameter	Symbol	Test Condition	Min	Typ	Max	Units
<b>Static Characteristics</b>						
Drain-Source Breakdown Voltage	$V_{DS}$	$V_{GS} = 0V, I_D = 250\mu A$	60			V
Gate Threshold Voltage*	$V_{GS(th)}$	$V_{DS} = V_{GS}, I_D = 1mA$	1	1.3	2.5	V
Zero Gate Voltage Drain Current	$I_{DSS}$	$V_{DS} = 48V, V_{GS} = 0V$			1	$\mu A$
Gate –Source leakage current	$I_{GSS1}$	$V_{GS} = \pm 20V, V_{DS} = 0V$			$\pm 10$	$\mu A$
	$I_{GSS2}$	$V_{GS} = \pm 10V, V_{DS} = 0V$			$\pm 200$	nA
	$I_{GSS3}$	$V_{GS} = \pm 5V, V_{DS} = 0V$			$\pm 100$	nA
Drain-Source On-Resistance*	$R_{DS(on)}$	$V_{GS} = 4.5V, I_D = 200mA$		1.1	5.3	$\Omega$
		$V_{GS} = 10V, I_D = 500mA$		0.9	5	$\Omega$
Diode Forward Voltage	$V_{SD}$	$V_{GS} = 0V, I_S = 300mA$			1.5	V
Recovered charge	$Q_r$	$V_{GS} = 0V, I_S = 300mA, V_R = 25V, di/dt = -100A/\mu S$		30		nC
<b>Dynamic Characteristics**</b>						
Input Capacitance	$C_{iss}$	$V_{DS} = 10V, V_{GS} = 0V, f = 1MHz$			40	pF
Output Capacitance	$C_{oss}$				30	pF
Reverse Transfer Capacitance	$C_{rss}$				10	pF
<b>Switching Characteristics**</b>						
Turn-On Delay Time	$t_{d(on)}$	$V_{GS} = 10V, V_{DD} = 50V, R_G = 50\Omega, R_{GS} = 50\Omega, R_L = 250\Omega$			10	ns
Turn-Off Delay Time	$t_{d(off)}$				15	ns
Reverse recovery Time	$t_{rr}$	$V_{GS} = 0V, I_S = 300mA, V_R = 25V, di/dt = -100A/\mu S$		30		ns
<b>GATE-SOURCE ZENER DIODE</b>						
Gate-Source Breakdown Voltage	$BV_{GSO}$	$I_{GS} = \pm 1mA$ (Open Drain)	$\pm 21.5$		$\pm 30$	V

**Notes :**

\*Pulse Test : Pulse Width  $\leq 300\mu s$ , Duty Cycle  $\leq 2\%$ .

\*\*These parameters have no way to verify.

# Typical Characteristics

Output Characteristics

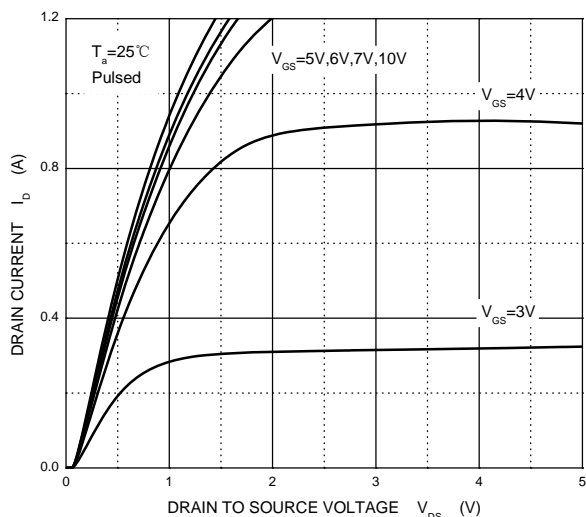

Transfer Characteristics

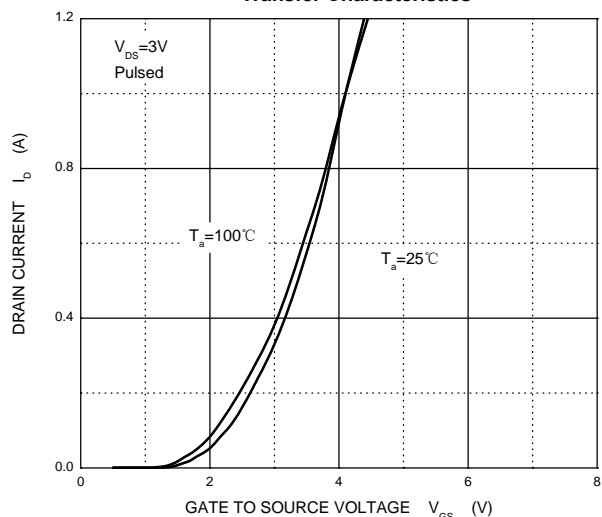

$R_{DS(ON)}$  —  $I_D$

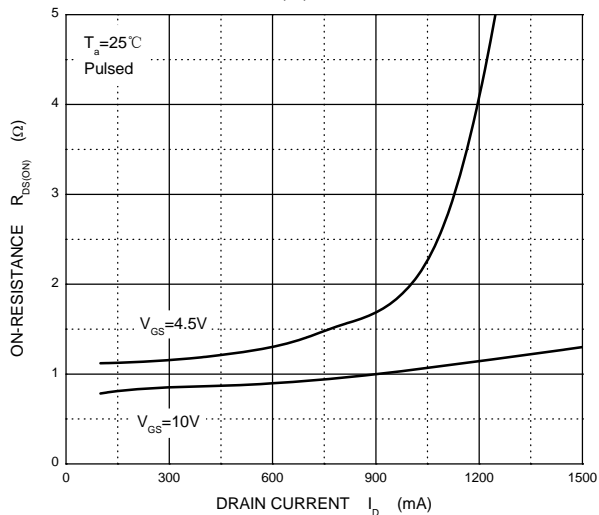

$R_{DS(ON)}$  —  $V_{GS}$

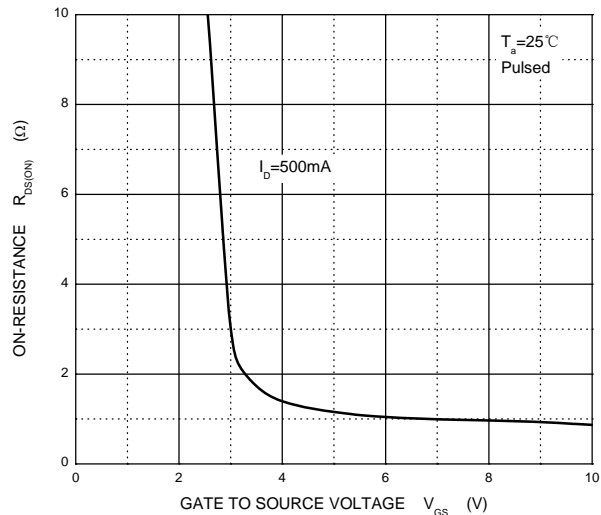

$I_S$  —  $V_{SD}$

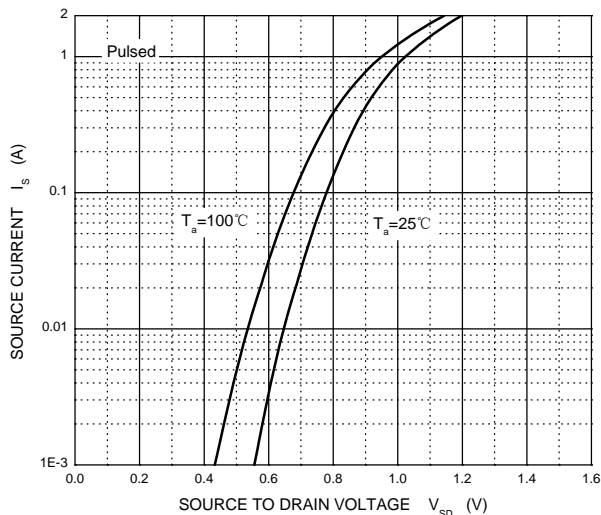

Threshold Voltage

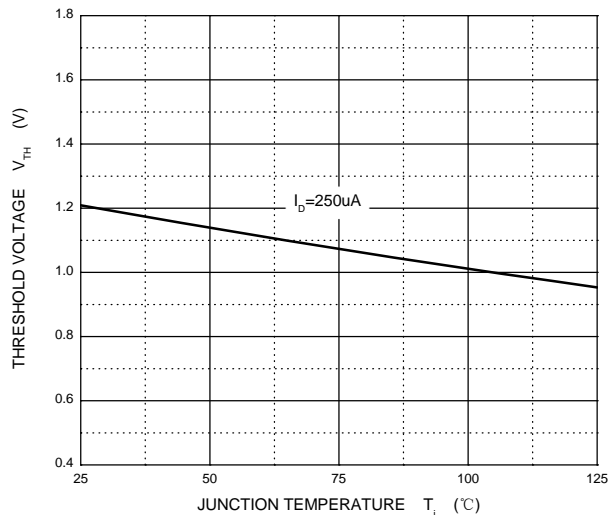

## TO-92 Package Outline Dimensions



Symbol	Dimensions In Millimeters		Dimensions In Inches	
	Min	Max	Min	Max
A	3.300	3.700	0.130	0.146
A1	1.100	1.400	0.043	0.055
b	0.380	0.550	0.015	0.022
c	0.360	0.510	0.014	0.020
D	4.300	4.700	0.169	0.185
D1	3.430		0.135	
E	4.300	4.700	0.169	0.185
e	1.270 TYP		0.050 TYP	
e1	2.440	2.640	0.096	0.104
L	14.100	14.500	0.555	0.571
Φ		1.600		0.063
h	0.000	0.380	0.000	0.015

## TO-92 Suggested Pad Layout



### Note:

1. Controlling dimension: in millimeters.
2. General tolerance:  $\pm 0.05\text{mm}$ .
3. The pad layout is for reference purposes only.

### NOTICE

JCET reserve the right to make modifications, enhancements, improvements, corrections or other changes without further notice to any product herein. JCET does not assume any liability arising out of the application or use of any product described herein.

TO-92 PACKAGE TAPEING DIMENSION

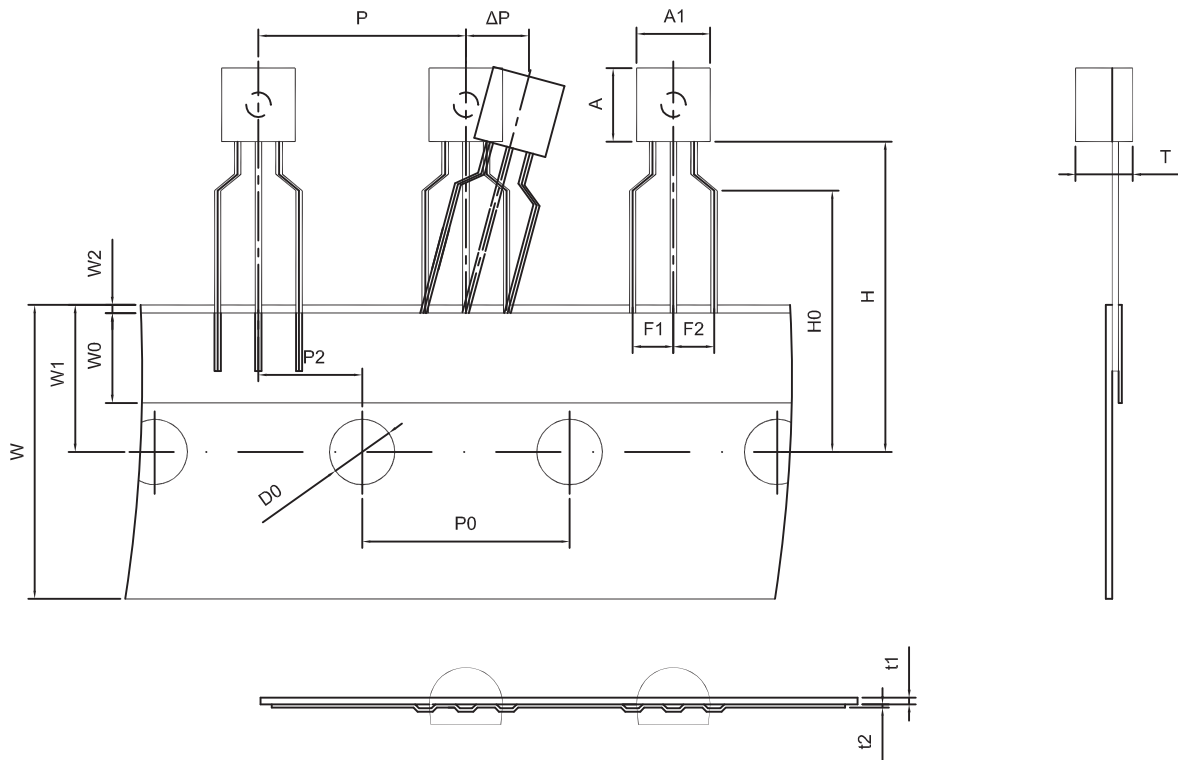

Dimiensions are in millimeter								
A1	A	T	P	P0	P2	F1	F2	W
4.5	4.5	3.5	12.7	12.7	6.35	2.5	2.5	18.0
W0	W1	W2	H	H0	D0	t1	t2	ΔP
6.0	9.0	1.0 MAX.	19.0	16.0	4.0	0.4	0.2	0

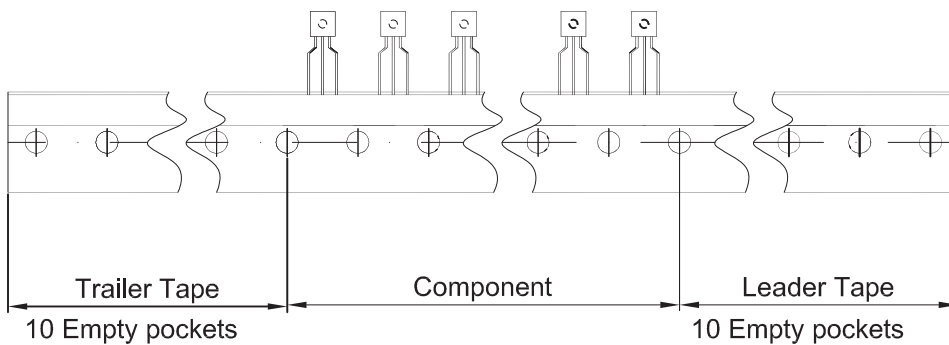

Package	Box	Box Size(mm)	Carton	Carton Size(mm)
TO-92	2000 pcs	333×162×43	20,000 pcs	350×340×250