

Fan, DC Types, 60 x 60mm

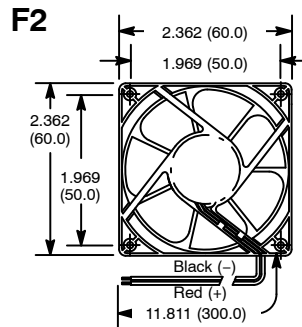

Features

- High Speed
- Ball Bearings
- 24 AWG Red (+) and Black (-) Leads
- 11.8" (300mm) Lead Length

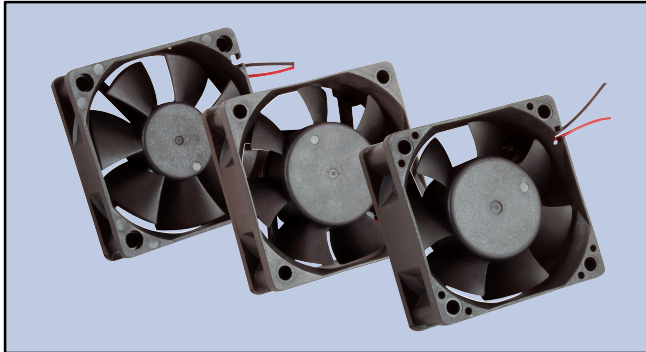

Type	Thickness "T"	
	DC	AC
6010	.409 (10.4)	N/A
6015	.610 (15.5)	N/A
6020	.787 (20.0)	N/A
6025	.984 (25.0)	N/A

a: Lead Types

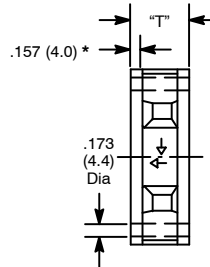

* 10mm Types: .098 (2.5); 15mm Types: .118 (3.0)

DC OPERATED							
NTE Type No.	Rated Voltage	Max. Input Current	Max. Input Power (W)	Speed 10% (RPM)	Max Air Flow (CFM)	Max Acoustical Noise	Diag No.
77-6010D24	24	0.13A	3.10	4200	18.50	39dB(A)	F2
77-6015D12	12	0.20A	2.35	4500	18.62	39dB(A)	F2
77-6015D24#	24	0.17A	4.14	4500	18.62	39dB(A)	F2
77-6020D12	12	0.18A	2.21	4200	22.43	38dB(A)	F2
77-6020D24#	24	0.15A	3.59	4200	22.43	38dB(A)	F2
77-6025D12	12	0.16A	1.93	4000	19.25	32dB(A)	F2
77-6025D24	24	0.16A	3.86	4000	19.25	32dB(A)	F2

These devices do not meet UL approval

ACCESSORIES		
FAN TYPE	DESCRIPTION	NTE TYPE NO.
60 X 60mm	Fan Guard, Metal	77-MG60
60 X 60mm	Fan Filter, 3-Piece w/Cover	77-FF60

Specifications

Electrical Characteristics

Insulation Resistance: 10MΩ Min. (at 500VDC) between frame and positive terminal

Dielectric Strength: 500VAC, 1 minute; 600VAC, 1 sec at 5mA Max. between frame and positive terminal

Life Expectancy: Approx. 70000 hours at rated voltage, +40°C, 15% to 65% RH

Mechanical Characteristics

Frame: Thermoplastic, Black, UL94V-0

Impeller: Thermoplastic, Black, UL94V-0

Bearing: 2 Ball Bearings

Weight: Approx. 23g (10mm); 34g (15mm); 50g (20mm); 62g (25mm)

Environmental Characteristics

Operating Temperature: -10°C to +70°C

Storage Temperature: -40°C to +75°C

Operating Humidity: 35% to 85% RH

Storage Humidity: 35% to 85% RH

Protection

Polarity: Damage will not occur for up to 10 minutes with positive and negative leads connected in reverse.

Locked Rotor: Within 72 hours of a rotor locking condition, at the rated voltage and operating temperature, the impedance of the motor winding will protect the motor from damage.