



P-DUKE POWER

QAE100W Series

Quarter-Brick DC-DC Converter
Up to 90 Watts

3
YEARS
WARRANTY

ROHS
COMPLIANT

REACH
COMPLIANT

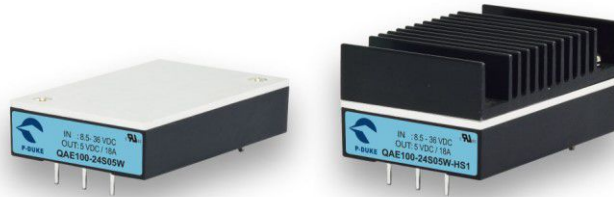

Railway



Automation



Datacom



IPC



Industry



Measurement



Telecom



Automobile



Boat



Charger



Medical



PV

UL US CB CE UK CA

3000
VAC
Reinforced
Insulation

2250
VDC
Basic
Insulation

4 : 1
Wide
Input
Range

NO
Min. Load
Required

LOW
Standby
Power

REMOTE
ON
OFF

OCP

OTP

OVP

SCP

UVP

PART NUMBER STRUCTURE

QAE100 -	48	S	05	W	-	P	HS
Series Name	Input Voltage (VDC)	Output Quantity	Output Voltage (VDC)	Input Range		Ctrl and Pin Options	Assembly Options
	24: 8.5~36 48: 16.5~75 110: 40~160	S:Single	3P3:3.3 05:5 12:12 15:15 24:24 30:30 48:48	4:1		□:Negative logic P:Positive logic	□: None Heat-sink type HS:7G-0029B-F; H=0.24" HS1:7G-0030B-F; H=0.5" HS2:7G-0031B-F; H=0.24" HS3:7G-0032B-F; H=0.5" HS4:7GA0124P01-F;H=0.65" HS5:7GA0125P01-F;H=1" Through hole type TH:No thread*

* The module can't equip Heat-sink with TH option.

TECHNICAL SPECIFICATION All specifications are typical at nominal input, full load and 25°C unless otherwise noted

Model Number	Input Range	Output Voltage	Output Current @Full Load	Input Current @No Load	Efficiency	Maximum Capacitor Load
	VDC	VDC	A	mA	%	μF
QAE100-24S3P3W	8.5 ~ 36	3.3	25	25	88	75000
QAE100-24S05W	8.5 ~ 36	5	18	25	89	36000
QAE100-24S12W	8.5 ~ 36	12	7.5	25	89	6250
QAE100-24S15W	8.5 ~ 36	15	6	25	89	4000
QAE100-24S24W	8.5 ~ 36	24	3.7	25	89	1540
QAE100-24S30W	8.5 ~ 36	30	3	25	89	1000
QAE100-24S48W	8.5 ~ 36	48	1.8	25	88	380
QAE100-48S3P3W	16.5 ~ 75	3.3	25	15	88	75000
QAE100-48S05W	16.5 ~ 75	5	18	15	89	36000
QAE100-48S12W	16.5 ~ 75	12	7.5	15	89	6250
QAE100-48S15W	16.5 ~ 75	15	6	15	90	4000
QAE100-48S24W	16.5 ~ 75	24	3.7	15	90	1540
QAE100-48S30W	16.5 ~ 75	30	3	15	90	1000
QAE100-48S48W	16.5 ~ 75	48	1.8	15	90	380
QAE100-110S3P3W	40 ~ 160	3.3	23	8	88	70000
QAE100-110S05W	40 ~ 160	5	17	8	89	34000
QAE100-110S12W	40 ~ 160	12	7	8	89	5830
QAE100-110S15W	40 ~ 160	15	5.5	8	89	3670
QAE100-110S24W	40 ~ 160	24	3.5	8	89	1460
QAE100-110S30W	40 ~ 160	30	2.8	8	89	930
QAE100-110S48W	40 ~ 160	48	1.8	8	89	380

INPUT SPECIFICATIONS						
Parameter	Conditions		Min.	Typ.	Max.	Unit
Operating input voltage range	24Vin(nom)		8.5	24	36	VDC
	48Vin(nom)		16.5	48	75	
	110Vin(nom)		40	110	160	
Start up voltage	24Vin(nom)				9	VDC
	48Vin(nom)				18	
	110Vin(nom)				43	
Shutdown voltage	24Vin(nom)		7.3	7.7	8.1	VDC
	48Vin(nom)		15.5	15.9	16.3	
	110Vin(nom)		33.0	34.5	36.0	
Start up time	Constant resistive load	Power up		75	100	ms
		Remote ON/OFF		75	100	
Input surge voltage	1 second, max.	24Vin(nom)			50	VDC
		48Vin(nom)			100	
		110Vin(nom)			185	
Input filter ⁽¹⁾			Pi type			
Remote ON/OFF	Referred to -Vin pin	Negative logic DC-DC ON			Short or 0 ~ 1.2VDC	
		(Standard) DC-DC OFF			Open or 3 ~ 12 VDC	
		Positive logic DC-DC ON			Open or 3 ~ 12 VDC	
		(Option) DC-DC OFF			Short or 0 ~ 1.2VDC	
		Input current of Ctrl pin	-0.5		1	mA
		Remote off input current		3		mA

OUTPUT SPECIFICATIONS						
Parameter	Conditions		Min.	Typ.	Max.	Unit
Voltage accuracy			-1.0		+1.0	%
Line regulation	Low Line to High Line at Full Load		-0.1		+0.1	%
Load regulation	No Load to Full Load	3.3 & 5Vout	-0.2		+0.2	%
		Others	-0.1		+0.1	
Voltage adjustability	Maximum output deviation is inclusive of remote sense		-20		+10	%
Remote sense	% of Vout(nom) If remote sense is not being used, sense pins should connect to the output pins with the same polarity.				10	%
Ripple and noise	Measured by 20MHz bandwidth			75		mVp-p
	With a 22 μ F/25V X7R MLCC	3.3Vout, 5Vout		100		
	With a 22 μ F/25V X7R MLCC	12Vout, 15Vout		200		
	With a 4.7 μ F/50V X7R MLCC	24Vout, 30Vout		300		
	With a 2.2 μ F/100V X7R MLCC	48Vout				
Temperature coefficient			-0.02		+0.02	%/°C
Transient response recovery time	25% load step change			250		μ s
Over voltage protection	% of Vout(nom); Hiccup mode		115		130	%
Over load protection	% of Iout rated; Hiccup mode		110		140	%
Short circuit protection			Continuous, automatic recovery			

GENERAL SPECIFICATIONS						
Parameter	Conditions		Min.	Typ.	Max.	Unit
Isolation voltage	1 minute	110Vin(nom) Input to Output	3000			VAC
	(Reinforced insulation)	Input (Output) to Base-Plate	1500			
	1 minute	Others Input to Output	2250			VDC
	(Basic insulation)	Input (Output) to Base-Plate	2250			
Isolation resistance	500VDC		1			G Ω
Isolation capacitance					1500	pF
Switching frequency			270	300	330	kHz
Safety approvals	IEC/ EN/ UL 62368-1					UL:E193009 CB:UL(Demko)
Standard approvals	EN50155 EN45545-2					
Case material			Aluminum base-plate with plastic case			
Potting material			Silicone (UL94 V-0)			
Weight			64g (2.26oz)			
MTBF	MIL-HDBK-217F, Full load		5.070 x 10 ⁵ hrs			

ENVIRONMENTAL SPECIFICATIONS						
Parameter	Conditions		Min.	Typ.	Max.	Unit
Operating base-plate temperature			-40		+105	°C
Maximum case temperature					105	°C
Over temperature protection				110		°C
Storage temperature range			-55		+125	°C
Thermal impedance	Module without assembly option			9		°C/W
	Only mount on the iron base-plate			2.8		
	Heat-sink type with 0.24" Height			7.1		
	Heat-sink type with 0.5" Height			5.5		
	Heat-sink type with 0.65" Height			4.2		
	Heat-sink type with 1" Height			3.4		
Thermal shock			MIL-STD-810F			
Shock			EN61373, MIL-STD-810F			
Vibration			EN61373, MIL-STD-810F			
Relative humidity			5% to 95% RH			

EMC SPECIFICATIONS

Parameter	Conditions	Level
EMI	EN55032, EN50121-3-2	With external components
EMS	EN55035, EN50121-3-2	
ESD	EN61000-4-2	Air $\pm 8kV$ and Contact $\pm 6kV$
Radiated immunity	EN61000-4-3	20 V/m
Fast transient	EN61000-4-4	$\pm 2kV$
Surge	QAE100-24S□□W QAE100-48S□□W	With 2 pcs of aluminum electrolytic capacitor (Nippon chemi-con KY series, 220 μ F/100V)
	QAE100-110S□□W	With 3 pcs of aluminum electrolytic capacitor (Ruby-con BXF series, 100 μ F/250V)
	EN61000-4-5	$\pm 2kV$
Conducted immunity	QAE100-24S□□W QAE100-48S□□W	With 2 pcs of aluminum electrolytic capacitor (Nippon chemi-con KY series, 220 μ F/100V)
	QAE100-110S□□W	With 3 pcs of aluminum electrolytic capacitor (Ruby-con BXF series, 100 μ F/250V)
	EN61000-4-6	10 Vr.m.s
Power frequency magnetic field	EN61000-4-8	100A/m continuous; 1000A/m 1 second

Note:

- Input source impedance: The power module will operate as specifications without external components, assuming that the source voltage has a very low impedance and reasonable input voltage regulation. Highly inductive source impedances can affect the stability of the power module. Since real-world voltage source has finite impedance, performance can be improved by adding external filter capacitor. The QAE100-24S□□W and QAE100-48S□□W recommended Nippon Chemi-con KY series, 100 μ F/100V. The QAE100-110S□□W recommended Ruby-con BXF series, 39 μ F/200V.
- BASE-PLATE GROUNDING: When connect two screw bolts to shield plane, the EMI could be reduced.

CAUTION: This power module is not internally fused. An input line fuse must always be used.

CHARACTERISTIC CURVE

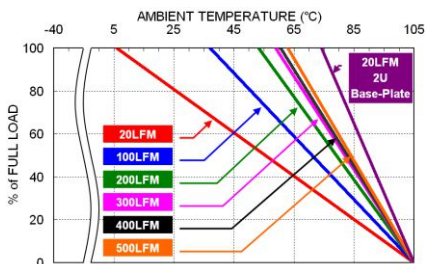

QAE100-24S05W Derating Curve

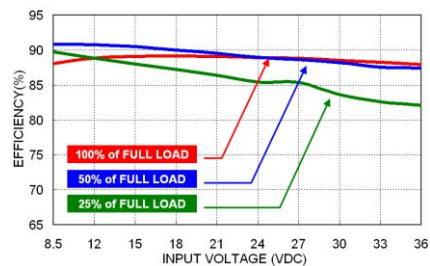

QAE100-24S05W Efficiency vs. Input Voltage

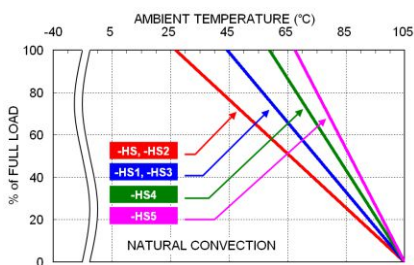

QAE100-24S05W Derating Curve with Heat-sink
(See Thermal Considerations)

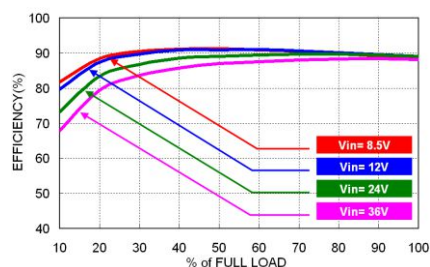

QAE100-24S05W Efficiency vs. Output Load

FUSE CONSIDERATION

This power module is not internally fused. An input line fuse must always be used.

This encapsulated power module can be used in a wide variety of applications, ranging from simple stand-alone operation to an integrated part of sophisticated power architecture.

To maximum flexibility, internal fusing is not included; however, to achieve maximum safety and system protection, always use an input line fuse.

The input line fuse suggest as below :

Model	Fuse Rating (A)	Fuse Type
QAE100-24S□□W	20	Fast-Acting
QAE100-48S□□W	10	Fast-Acting
QAE100-110S□□W	4	Slow-Blow

The table based on the information provided in this data sheet on inrush energy and maximum DC input current at low Vin.

MECHANICAL DRAWING

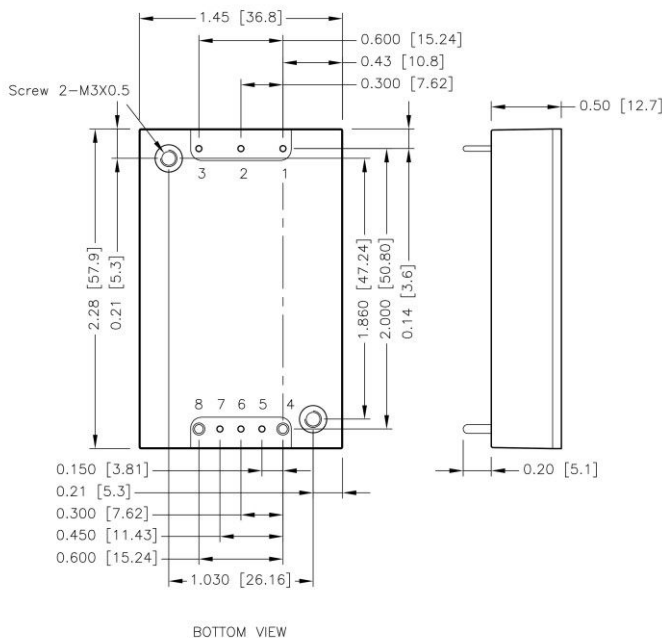

PIN CONNECTION

PIN	DEFINE	DIAMETER
1	- Vin	0.04 Inch
2	Ctrl	0.04 Inch
3	+ Vin	0.04 Inch
4	- Vout	0.06 Inch
5	- Sense	0.04 Inch
6	Trim	0.04 Inch
7	+ Sense	0.04 Inch
8	+ Vout	0.06 Inch

- All dimensions in inch [mm]
- Tolerance :x.xx±0.02 [x.x±0.5]
x.xxx±0.010 [x.xx±0.25]
- Pin dimension tolerance ±0.004[0.10]
- The screw locked torque:MAX 3.5kgf-cm [0.34N-m]

RECOMMENDED PAD LAYOUT

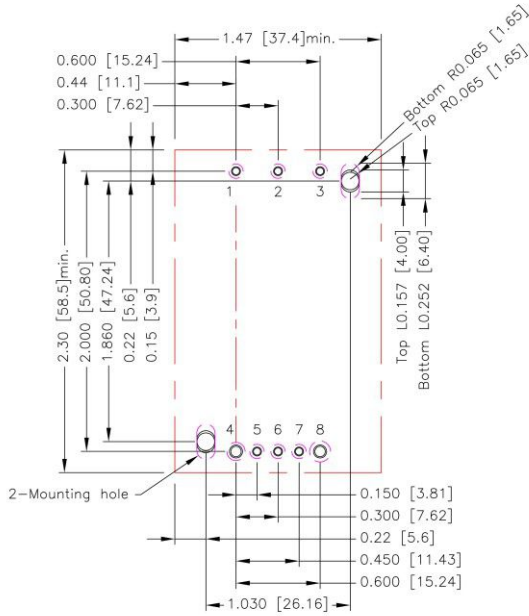

All dimensions in inch[mm]
 Pad size(lead free recommended)
 Through hole 1.2.3.5.6.7: $\varnothing 0.051[1.30]$
 Through hole 4.8: $\varnothing 0.075[1.90]$
 Through hole of mounting: $\varnothing 0.126[3.20]$
 Top view pad 1.2.3.5.6.7: $\varnothing 0.064[1.63]$
 Top view pad 4.8: $\varnothing 0.094[2.38]$
 Top view pad of mounting: Groove R0.065[1.65]L0.157[4.00]
 Bottom view pad 1.2.3.5.6.7: $\varnothing 0.102[2.60]$
 Bottom view pad 8: $\varnothing 0.150[3.80]$
 Bottom view pad 4: $\varnothing 0.130[3.30]$
 Bottom view pad of mounting: Groove R0.065[1.65]L0.252[6.40]

THERMAL CONSIDERATIONS

The power module operates in a variety of thermal environments. However, sufficient cooling should be provided to help ensure reliable operation of the unit. Heat is removed by conduction, convection, and radiation to the surrounding environment. Proper cooling can be verified by measuring the point as the figure below. The temperature at this location should not exceed "Maximum case temperature". When operating, adequate cooling must be provided to maintain the test point temperature at or below "Maximum case temperature". You can limit this temperature to a lower value for extremely high reliability.

- Thermal test condition with vertical direction by natural convection (20LFM).
- The iron base-plate dimension is 19" X 3.5" X 0.063" (The height is EIA standard 2U).
- The heat-sink is optional and P/N: 7G-0029B-F, 7G-0030B-F, 7G-0031B-F, 7G-0032B-F, 7GA0124P01-F, 7GA0125P01-F.

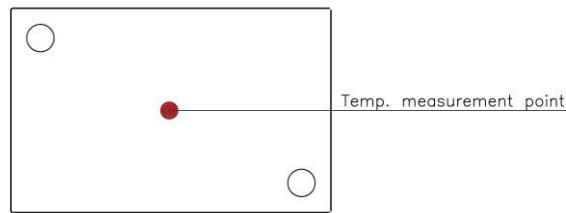

BASE PLATE

HEAT-SINK TYPE OPTIONS

QAE100-□□S□□W -HS
7G-0029B-F

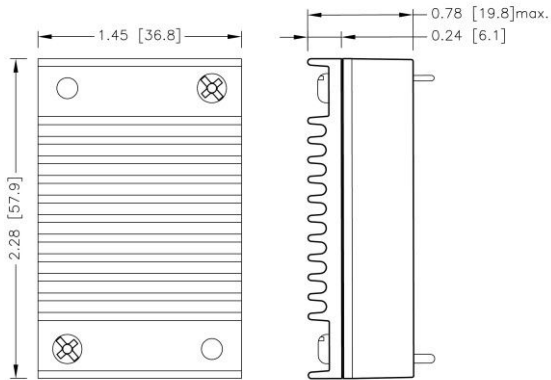

QAE100-□□S□□W -HS1
7G-0030B-F

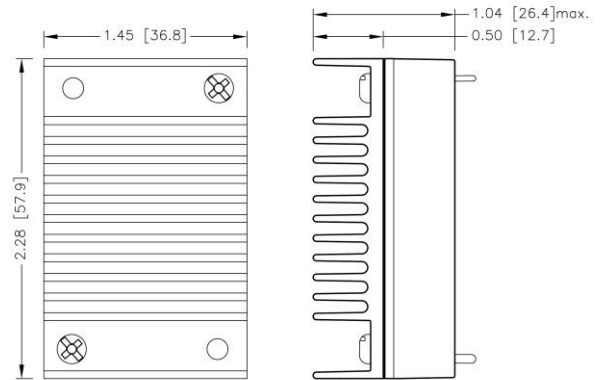

QAE100-□□S□□W -HS2
7G-0031B-F

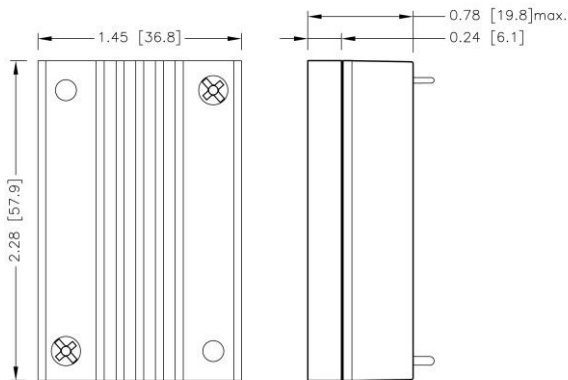

QAE100-□□S□□W -HS3
7G-0032B-F

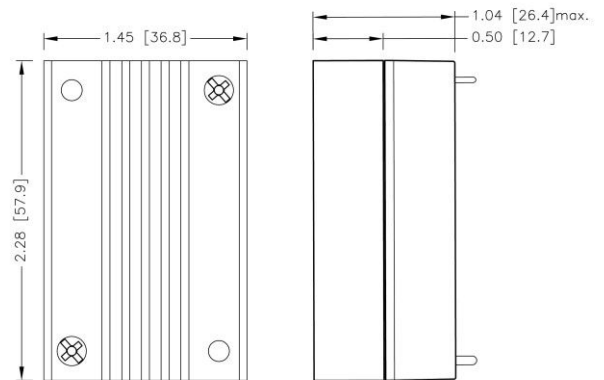

QAE100-□□S□□W -HS4
7GA0124P01-F

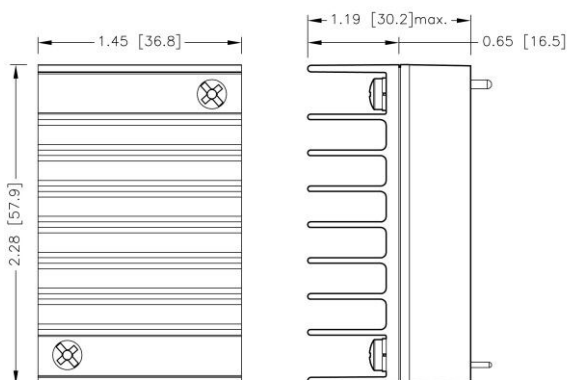

QAE100-□□S□□W -HS5
7GA0125P01-F

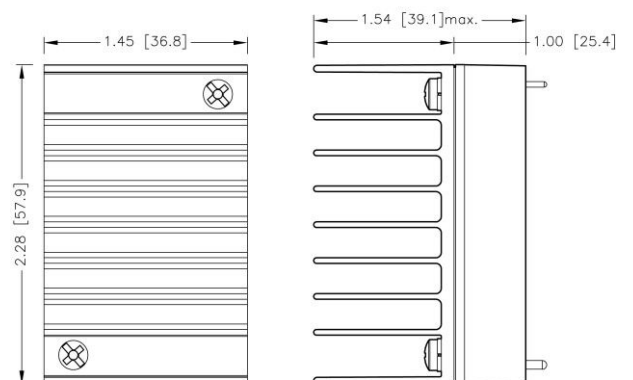

1. All dimensions in inch [mm]
2. Tolerance :x.xx±0.02 [x.x±0.5]

OUTPUT VOLTAGE ADJUSTMENT

Output voltage is adjustable for 10% trim up or -20% trim down of nominal output voltage by connecting an external resistor between the Trim pin and either the +Sense or -Sense pins.

With an external resistor between the Trim and -Sense pin, the output voltage set point decreases.

With an external resistor between the Trim and +Sense pin, the output voltage set point increases.

Maximum output deviation is +10% inclusive of remote sense.

The external Trim resistor needs to be at least 1/8W of rated power.

Trim Up Equation

$$R_U = \left(\frac{5.11V_{OUT}(100 + \Delta\%)}{1.225\Delta\%} - \frac{511 + 10.22\Delta\%}{\Delta\%} \right) k\Omega$$

Trim Down Equation

$$R_D = \left(\frac{511}{\Delta\%} - 10.22 \right) k\Omega$$

EXTERNAL OUTPUT TRIMMING

Output can be externally trimmed by using the method shown below.

Trim-up

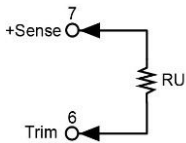

□□S3P3W

ΔV (%)	1	2	3	4	5	6	7	8	9	10
Vout (V)	3.333	3.366	3.399	3.432	3.465	3.498	3.531	3.564	3.597	3.630
RU (k Ω)	869.117	436.331	292.07	219.939	176.66	147.808	127.198	111.742	99.72	90.103

□□S05W

ΔV (%)	1	2	3	4	5	6	7	8	9	10
Vout (V)	5.05	5.10	5.15	5.20	5.25	5.30	5.35	5.40	5.45	5.50
RU (k Ω)	1585.35	797.994	535.542	404.316	325.58	273.09	235.596	207.476	185.605	168.109

□□S12W

ΔV (%)	1	2	3	4	5	6	7	8	9	10
Vout (V)	12.12	12.24	12.36	12.48	12.60	12.72	12.84	12.96	13.08	13.20
RU (k Ω)	4534.55	2287.19	1538.08	1163.52	938.78	788.956	681.939	601.676	539.25	489.309

□□S15W

ΔV (%)	1	2	3	4	5	6	7	8	9	10
Vout (V)	15.15	15.30	15.45	15.60	15.75	15.90	16.05	16.20	16.35	16.50
RU (k Ω)	5798.49	2925.42	1967.73	1488.89	1201.58	1010.04	873.229	770.619	690.812	626.966

□□S24W

ΔV (%)	1	2	3	4	5	6	7	8	9	10
Vout (V)	24.24	24.48	24.72	24.96	25.20	25.44	25.68	25.92	26.16	26.40
RU (k Ω)	9590.32	4840.11	3256.7	2465	1989.98	1673.3	1447.1	1277.45	1145.5	1039.94

□□S30W

ΔV (%)	1	2	3	4	5	6	7	8	9	10
Vout (V)	30.3	30.6	30.9	31.2	31.5	31.8	32.1	32.4	32.7	33
RU (k Ω)	12118.2	6116.57	4116.02	3115.74	2515.58	2115.47	1829.68	1615.33	1448.62	1315.25

□□S48W

ΔV (%)	1	2	3	4	5	6	7	8	9	10
Vout (V)	48.48	48.96	49.44	49.92	50.40	50.88	51.36	51.84	52.32	52.80
RU (k Ω)	19701.9	9945.94	6693.96	5067.97	4092.38	3441.99	2977.42	2628.99	2357.99	2141.19

OUTPUT VOLTAGE ADJUSTMENT(CONTINUED)

Trim-down

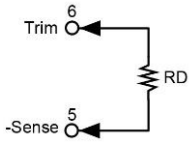

□□S□□W

ΔV (%)	1	2	3	4	5	6	7	8	9	10
RD (k Ω)	500.78	245.28	160.113	117.53	91.98	74.947	62.78	53.655	46.558	40.88
ΔV (%)	11	12	13	14	15	16	17	18	19	20
RD (k Ω)	36.235	32.363	29.088	26.28	23.847	21.718	19.839	18.169	16.675	15.33