



LEGEND
 = CRITICAL INSPECTION DIMENSIONS.
 = KEY PRODUCT CHARACTERISTICS



SEE NOTE 4.

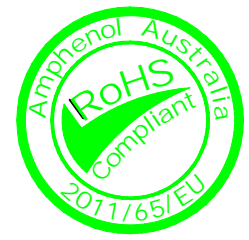
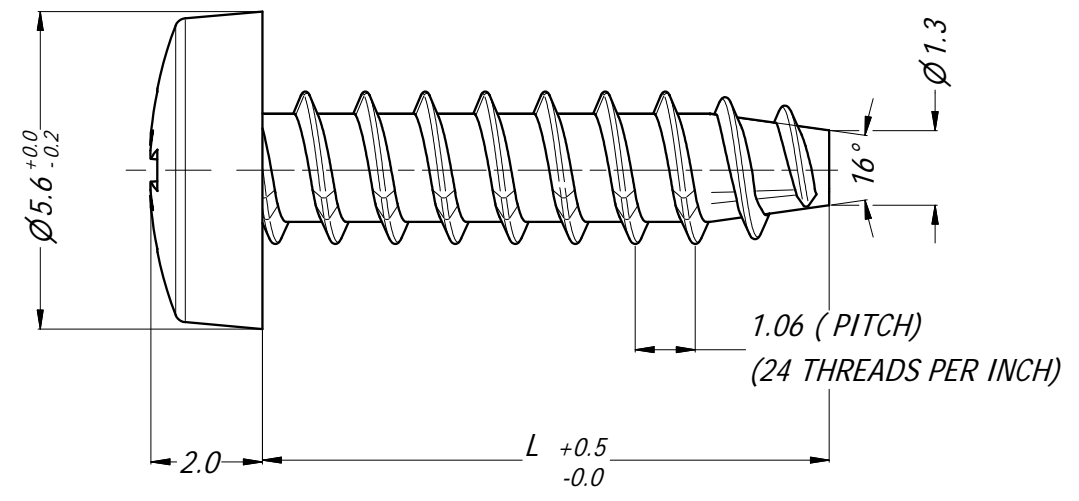
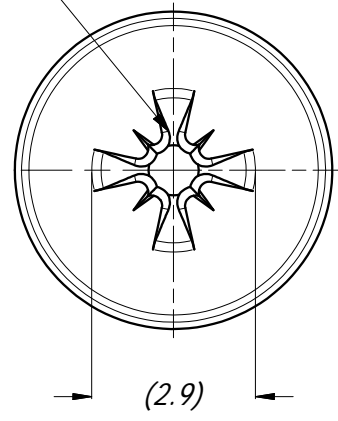

- NOTES:
1. MATERIAL: MEDIUM CARBON STEEL, HARDENED TO 50-55 HRC
 2. FINISH: BLACK COATING
 3. ALL MATERIAL SHALL BE RoHS & REACH COMPLIANT.
 4. CROSS RECESSES TYPE 1A AS PER ANSI B18.6.4-1981, R1991

TABLE OF PART No.

PART No.	LENGTH L
52500014-734	7.8
52500014-735	10.0

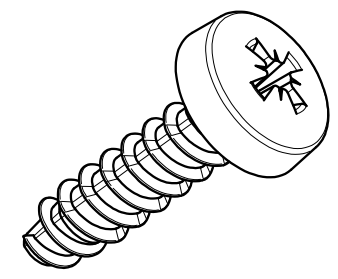

3D VIEW
4:1

UNLESS OTHERWISE SPECIFIED TOLERANCE TO BE		THIS DOCUMENT IS THE PROPERTY OF AMPHENOL AUSTRALIA PTY. LTD. NO PART THEREOF MAY BE REPRODUCED AND USED WITHOUT THE PRIOR WRITTEN CONSENT OF THE OWNER.				Amphenol Amphenol Australia Pty.Ltd, 22 Industry Blvd Carrum Downs, VIC 3201	
LINEAR	ANGULAR	MATERIAL:	DRN:	T.N	DATE:	TITLE:	PART No:
X ± 0.5	X' ± 1	CARBON STEEL	CKD:	P.M	DATE:	SCREW 2.9 x 1.06	SEE TABLE
X.X ± 0.1	X.X' ± 30'		APP'D:	P.M	DATE:	TRI-ROUNDULAR THREAD	1
X.XX ± 0.05	X.XX' ± 15'	FINISH:	SCALE:	SIZE:	A4	CUSTOMER DWG	DRAWING No.
BREAK ALL SHARP EDGES AND REMOVE ALL BURRS		DO NOT SCALE	THIRD ANGLE PROJECTION		DRAWING No.		SHEET
DIMENSIONS IN MILLIMETRES						52500014-734-1	2/2