

**MATERIAL**

C10 zinc-plated steel.

**RIVETS**

Zinc-plated steel.

**PULLING PIN AND HOOK**

Zinc-plated steel.

**HANDLE**

Polyurethane, red colour.

**STANDARD EXECUTIONS**

- **MTA-T**: with pulling pin.
- **MTA-TF**: with pulling hook.

**FEATURES AND APPLICATIONS**

All articulated joints are lubricated with special grease.  
 MTA. clamps ensure tight closing of any cover.  
 The position of the pulling hook (MTA-TF) can be adjusted according to specific applications.

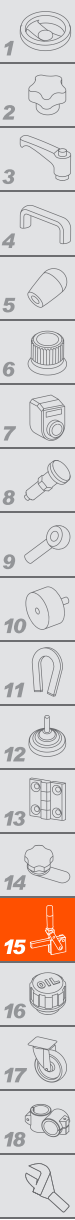
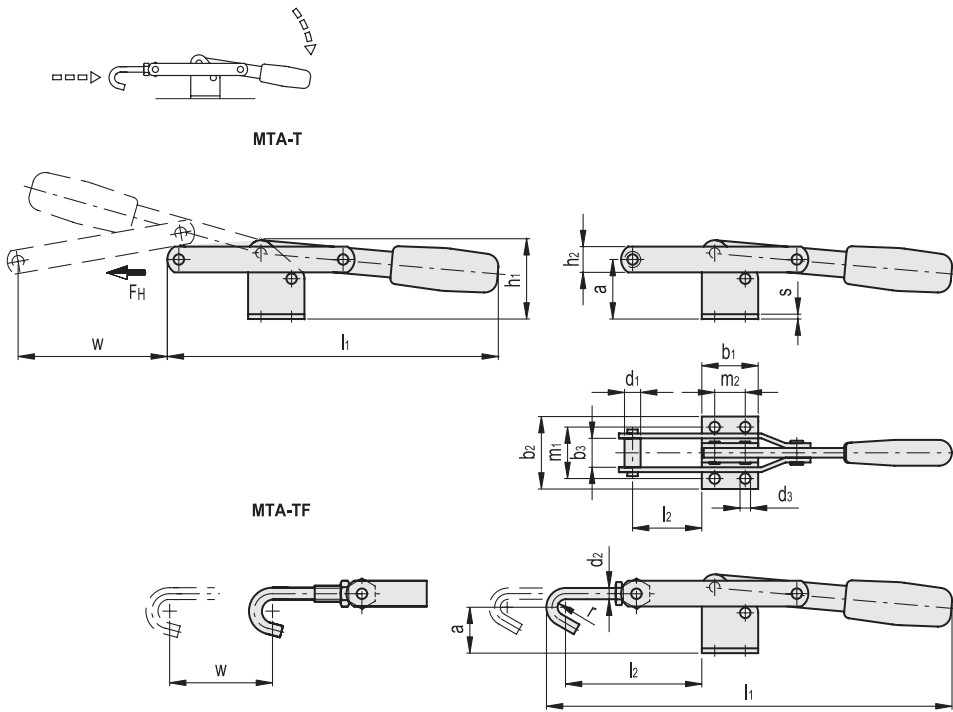

**MTA-T**

**METRIC**

Code	Description	a	b1	b2	b3	d1	d3	h1	h2	l1	l2	m1	m2	s	Stroke w	FH [N]*	
GG.AL200	MTA.200-T	37	35	45	18	10	6.5	49	16	203	43	32	19	3	100	2000	300
GG.AL300	MTA.300-T	35	48	60	21	10	8.3	49	18	226	43	45	32	3	104	3000	460
GG.AL400	MTA.400-T	43	54	84	26	14	10.5	60.5	25	278	45.5	60.5	28.5	5	160	4000	1000

**MTA-TF**

**METRIC**

Code	Description	a	b1	b2	d2	d3	h1	h2	l1	l2	m1	m2	r	s	Stroke w	FH [N]*	
GG.AL205	MTA.200-TF	29	35	45	8	6.5	49	16	250	85+105	32	19	5	3	100	2000	380
GG.AL305	MTA.300-TF	25	48	60	10	8.5	49	18	305	90+120	45	32	6	3	104	3000	560
GG.AL405	MTA.400-TF	30	54	84	11	10.5	60.5	25	343	105+135	60.5	28.5	7	5	160	4000	1200

\* Holding force.