

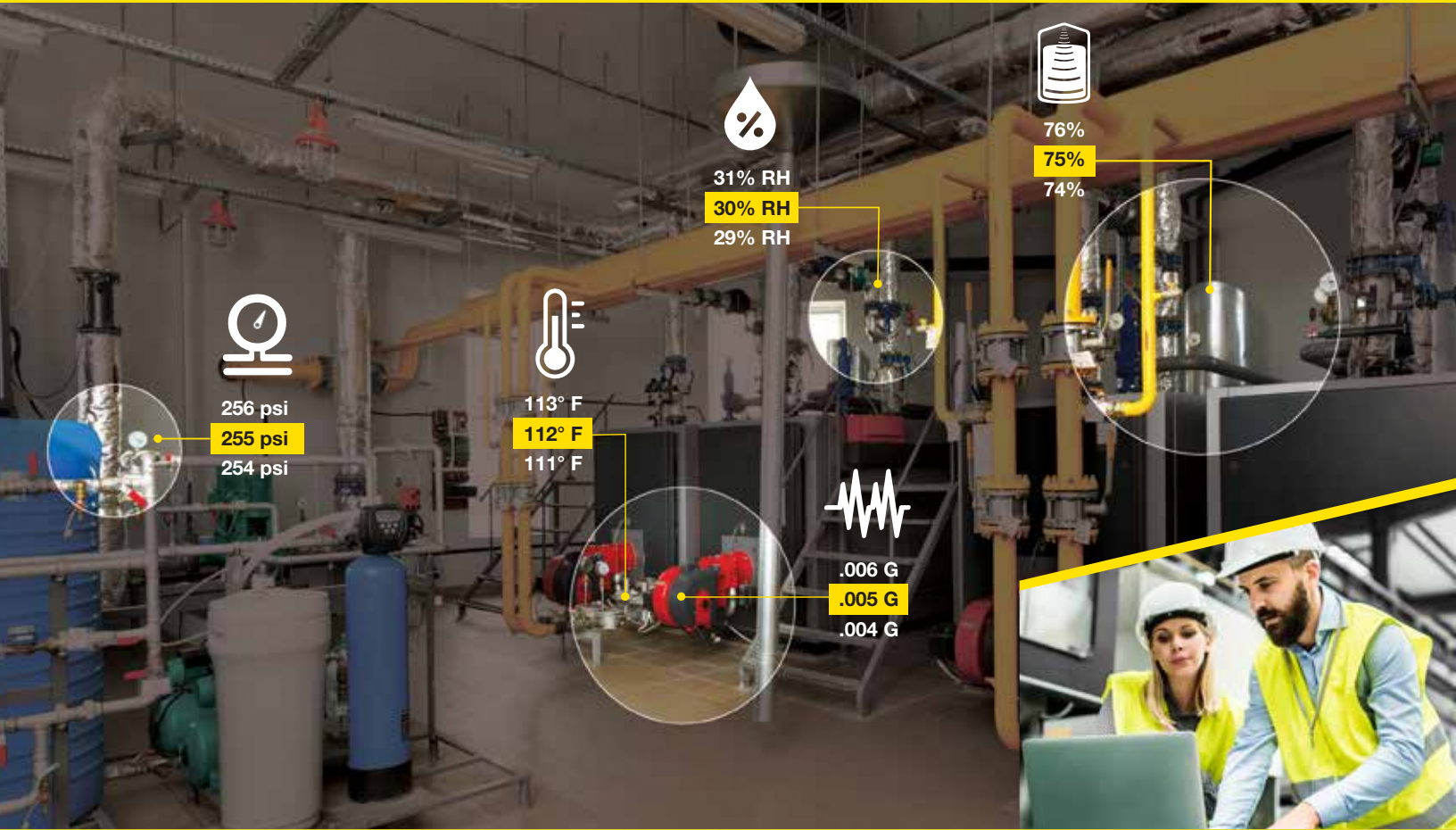

# SmartSolutions™ StarterKit

## Vibration Monitoring



### Validate with data. Provide Savings. Increase Value.

- Products with proven wireless communication and integrated cellular connectivity
- Configurable dashboards with default alarms assist in data-driven decisions and solutions
- Battery-powered devices for convenient installation
- Durable IP-rated sensors and gateways

### Kit includes:



Vibration Monitoring Sensor



Wireless Gateway



Prepaid Cellular and Banner Cloud Data Services

### The turn-key, essential solution to kick-start predictive maintenance initiatives

Identify equipment problems before a failure occurs by monitoring the health of motors, fans, pumps, and similar equipment. This kit includes Banner Engineering's market-leading sensor technology, assuring you fast and powerful insights key to preventing asset failure. Automatically set a baseline for the health of an asset with machine learning software embedded in your cloud instance. View graphs, create alerts, store, and analyze the data from multiple assets using the Banner Cloud Data Services platform.

# SmartSolutions™ StarterKit

## Begin Your IIoT Journey with Banner

### Kit Features:

- Connect a total of 10 sensor nodes for your specific application needs
- Preconfigured gateway provides time-saving Direct-to-Cloud functionality
- Wireless Gateway options for indoor and outdoor asset monitoring and communication
- Proven secure and reliable communications between sensors and the gateway (FHSS)
- 900 MHz ISM Radio for up to 50 times larger range than Bluetooth
- LCD user interface for sensor-binding process

### Acquire insights with one Direct-to-Cloud Solution

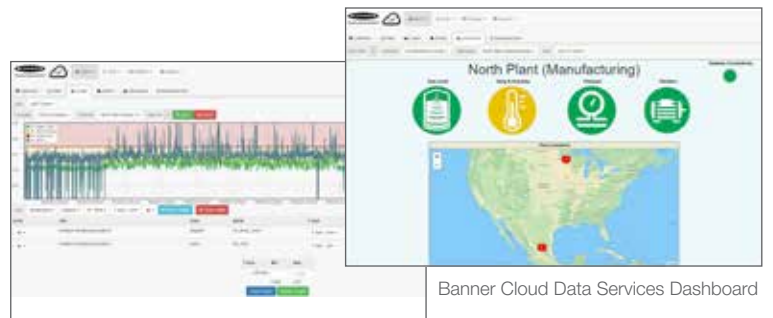
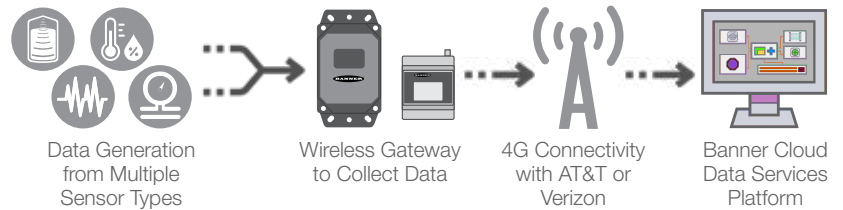

### The SmartSolutions™ StarterKit Series

Designed to enable owners of assets and processes to obtain actionable insights that will solve industrial challenges delivered in a robust and easily deployable solution. From high-grade sensing hardware and gateways, to trusted network connectivity and intuitive software, the SmartSolutions™ StarterKit Series provides the entire stack of technologies needed to evaluate the Industrial Internet of Things (IIoT) within an enterprise.

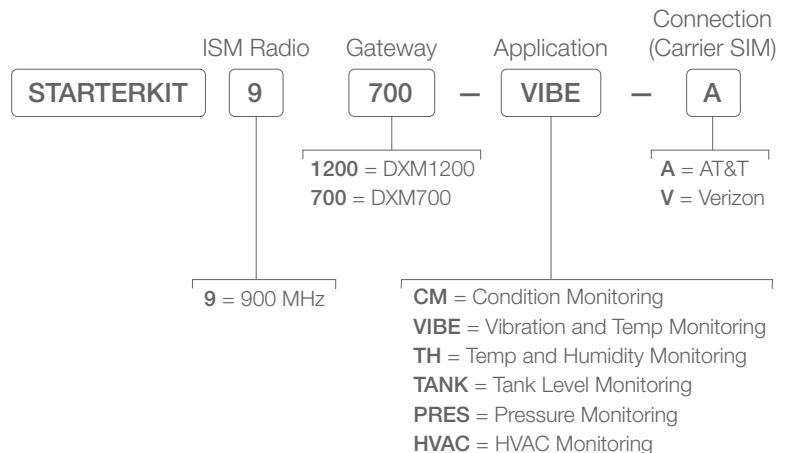

"Took no time to install, paid for itself and made me look good. Thanks!"

Matt M. - Sr Facility Manager

### Designed to get up to speed quickly and scale with ease

The SmartSolutions™ StarterKit can deliver value in minutes, not hours or days. Add any additional industrial grade All-In-One Sensor Node to the StarterKit and adapt the system for the specific requirements of the application or facility.

#### Wireless Gateways



DXM1200 (Sealed)

DXM700

#### All-in-One Sensor Nodes



Vibration

Temp/Humidity

Tank Level

Pressure

Temp Probe



# DXM700 Wireless Gateway

Banner's Wireless Gateway is an industrial wireless device that facilitates Industrial Internet of Things (IIoT) applications. As a communications gateway, it offers seamless connectivity by hosting a robust ISM radio network for local wireless devices used to acquire and transmit data from assets with the industrial environment. The intuitive on-board display is used to bind the radios to the wireless network and an internal cellular modem provides a preconfigured connection to a 4G LTE network.

- ISM local radio network available in 900 MHz frequency band
- DIN-rail mounting for use in factory floor and enclosure environments
- DC Power Supply included within SmartSolutions™ StarterKit
- Embedded cellular connection with Verizon or AT&T carriers
- External radio and cellular antennas for increased reception or extension
- Ethernet connection available



Models	Description
DXM700-B2R1-SK-V	ISM 900 MHz Radio; preconfigured device detection with Verizon cellular module & SIM
DXM700-B2R1-SK-A	ISM 900 MHz Radio; preconfigured device detection with AT&T cellular module & SIM

Specifications	
Supply Voltage	12 to 30 V DC (use only with a suitable Class 2 power supply (UL) or a Limited Power Source (LPS) (CE) power supply)
Construction	Polycarbonate; DIN rail mount option
Environmental Rating	IEC IP20
Operating Conditions	-20 to +60 °C (-4 to +140 °F)
Security Protocol	VPN, SSL, HTTPS
Push to Cloud Rate	Once every 10 minutes
900 MHz Compliance	FCC ID UE3RM1809: FCC Part 15, Subpart C, 15.247 IC: 7044A-RM1809 IFT: RCPBARM13-2283
Certifications	 

## Support Literature

207894	Sure Cross® DXM700-Bx Wireless Controller Instruction Manual
207893	Sure Cross® DXM700-Bx Wireless Controller Datasheet

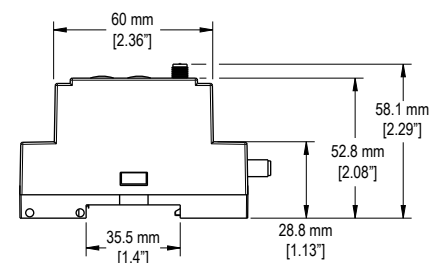
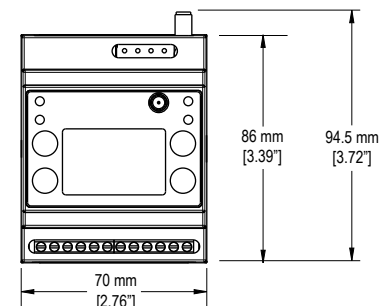

# Q45VA All-in-One Vibration Sensor Node

Q45VA devices combine an ISM radio, sensor, and battery power supply into one easy-to-deploy Sensor Node. The Q45VA is a compact industrial-grade device specially designed to analyze vibration and temperature data that can be used to identify and predict failures for rotating machinery.

- Delivers pre-processed high accuracy vibration values for monitoring rotating equipment such as motors, pumps, rotary compressors, exhaust or HVAC fan motors, and spindles.
- Achieves vibration accuracy of  $\pm 10\%$  RMS velocity (in/sec)
- 2+ years of battery life with simple installation (Two mounting bracket options included)
- Detects vibration characteristics on two axis (radial and axial) and two bands of RMS velocity and High Frequency Acceleration



Models*	Radio Frequency	Inputs & Outputs
DX80N9Q45VA-BK	900 MHz ISM Band	Vibration and temperature detection

(BWA-BK-009 and BWA-BK-010 (magnetic) Mounting Brackets included)

\* Additional sensors available to add to the StarterKit Series. See last page for more information.

## Specifications

<b>Construction</b>	Molded reinforced thermoplastic polyester housing, oring-sealed transparent Lexan® cover, molded acrylic lenses, and stainless steel hardware. Designed to withstand 1200 psi washdown.
<b>Environmental Rating</b>	NEMA 6P, IEC IP67
<b>Operating Conditions</b>	Ambient temperature: $-40$ to $+70$ °C ( $-40$ to $+158$ °F) Contact temperature: $-40$ to $+105$ °C ( $-40$ to $+221$ °F)
<b>Vibration Sensor</b>	Measuring Range: 0 to 46 mm/sec or 0 to 1.8 in/sec RMS Frequency Range: 10 Hz to 4 kHz Accuracy: $\pm 10\%$ at 25 °C Sampling Frequency: 20 kHz (default) Record Length: 8192 points (default) Sample Duration: 0.4 s (default)
<b>Temperature Sensor</b>	Measuring Range: $-40$ to $+105$ °C ( $-40$ to $+221$ °F)
<b>Default Sensing Interval</b>	5 minutes
<b>900 MHz Compliance</b>	FCC ID UE3RM1809: FCC Part 15, Subpart C, 15.247 IC: 7044A-RM1809 IFT: RCPBARM13-2283
<b>Certifications</b>	

## Support Literature

205704	Sure Cross® Wireless Q45VA All-in-One Vibration and Temperature Node Data sheet
208986	Q45VA Sensor Mounting Options Quick Start Guide

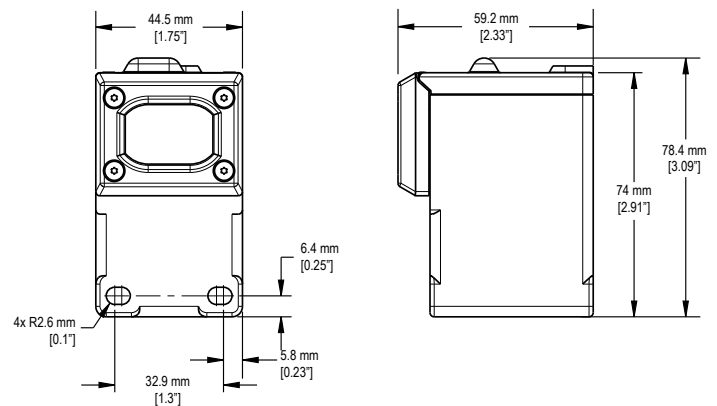

# Additional Sensor Nodes to Expand your StarterKit

Add additional devices for up to 10 sensor nodes per gateway that monitor tank level, ambient temperature and humidity, the health of rotating machines and pressurized conditions.

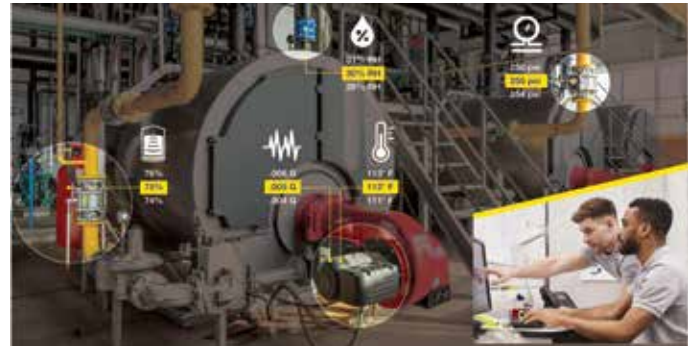

Banner Engineering has hundreds of sensor solutions to meet your needs. Please visit [BannerEngineering.com](http://BannerEngineering.com) to discover the right solution for your specialized applications.

## All-in-One Ultrasonic Sensor Node



Models	Radio Frequency	Ultrasonic input Range and Frequency	Inputs
DX80N9Q45UAA	900 MHz ISM Band	Range: 100 mm to 1 m (3.94 in to 39.4 in) Frequency: 240 kHz	Inputs: One Ultrasonic Input, One Thermistor Input
DX80N9Q45UAC	900 MHz ISM Band	Range: 300 mm to 3 m (11.8 in to 118 in) Frequency: 114 kHz	

## Wireless Node and Quick-Disconnect Pressure Sensor (must be purchased together)



Models	Radio Frequency	Pressure Range	Inputs
DX80N9Q45UPSD	900 MHz ISM Band	Universal	Pressure
BWA-PRESSURE-SENSOR-15	1 Wire Serial	0-15 PSI	
BWA-PRESSURE-SENSOR-50	1 Wire Serial	0-50 PSI	
BWA-PRESSURE-SENSOR-150	1 Wire Serial	0-150 PSI	
BWA-PRESSURE-SENSOR-500	1 Wire Serial	0-500 PSI	
BWA-PRESSURE-SENSOR-3000	1 Wire Serial	0-3000 PSI	

## All-in-One Temperature and Humidity Sensor Node



Models	Radio Frequency	Measurement Range	Inputs
DX80N9Q45THA	900 MHz ISM Band	-40 to +85 °C (-40 to +185 °F) 0 to 100% Relative Humidity	Temperature and relative humidity (%)

## All-in-One Temperature Probe Sensor Node



Models	Radio Frequency	Measurement Range	Inputs
DX80N9Q45TA	900 MHz ISM Band	-20 to +105 °C (-4 to +221 °F)	Temperature

## Wireless Node and Compact Vibration Sensor (must be purchased together)



Models	Communication	Radio Frequency	Inputs & Outputs
DX80N9Q45VTP	ISM Radio Band	900 MHz	Vibration and temperature detection
QM30VT1	1-Wire Serial	-	