

TMS320DM647/TMS320DM648 Digital Media Processor

Check for Samples: [TMS320DM647](#), [TMS320DM648](#)

1 Features

- **High-Performance Digital Media Processor**
 - 720-MHz, 800-MHz, 900-MHz, 1.1-GHz C64x+™ Clock Rates
 - 1.39 ns (-720), 1.25 ns (-800), 1.11 ns (-900), 0.91 ns (-1100) Instruction Cycle Time
 - 5760, 6400, 7200, 8800 MIPS
 - Eight 32-Bit C64x+ Instructions/Cycle
 - Fully Software-Compatible With C64x/Debug
 - Commercial Temperature Ranges (-720, -900, and -1100 only)
 - Extended Temperature Ranges (-800 only)
 - Industrial Temperature Ranges (-720, -900, and -1100 only)
- **VelociTI.2™ Extensions to VelociTI™ Advanced Very-Long-Instruction-Word (VLIW) TMS320C64x+™ DSP Core**
 - Eight Highly Independent Functional Units With VelociTI.2 Extensions:
 - Six ALUs (32-/40-Bit), Each Supports Single 32-bit, Dual 16-bit, or Quad 8-bit Arithmetic per Clock Cycle
 - Two Multipliers Support Four 16 x 16-bit Multiplies (32-bit Results) per Clock Cycle or Eight 8 x 8-bit Multiplies (16-Bit Results) per Clock Cycle
 - Load-Store Architecture With Non-Aligned Support
 - 64 32-bit General-Purpose Registers
 - Instruction Packing Reduces Code Size
 - All Instructions Conditional
 - Additional C64x+™ Enhancements
 - Protected Mode Operation
 - Exceptions Support for Error Detection and Program Redirection
 - Hardware Support for Modulo Loop Auto-Focus Module Operation
- **C64x+ Instruction Set Features**
 - Byte-Addressable (8-/16-/32-/64-bit Data)
 - 8-bit Overflow Protection
 - Bit-Field Extract, Set, Clear
 - Normalization, Saturation, Bit-Counting
 - VelociTI.2 Increased Orthogonality
 - C64x+ Extensions
 - Compact 16-bit Instructions
 - Additional Instructions to Support Complex Multiplies
- **C64x+ L1/L2 Memory Architecture**
 - 256K-bit (32K-byte) L1P Program RAM/Cache [Direct Mapped]
 - 256K-bit (32K-byte) L1D Data RAM/Cache [2-Way Set-Associative]
 - 2M-bit/256K-byte (DM647) or 4M-Bit/512K-byte (DM648) L2 Unified Mapped RAM/Cache [Flexible Allocation]
- **Supports Little Endian Mode Only**
- **Five Configurable Video Ports**
 - Providing a Glueless I/F to Common Video Decoder and Encoder Devices
 - Supports Multiple Resolutions/Video Standards
- **VCXO Interpolated Control Port (VIC)**
 - Supports Audio/Video Synchronization
- **External Memory Interfaces (EMIFs)**
 - 32-Bit DDR2 SDRAM Memory Controller With 512M-Byte Address Space (1.8-V I/O)
 - Asynchronous 16-Bit Wide EMIF (EMIFA)
 - Up to 128M-Byte Total Address Reach
 - 64M-Byte Address Reach per CE Space
 - Glueless Interface to Asynchronous Memories (SRAM, Flash, and EEPROM)
 - Synchronous Memories (SBSRAM and ZBT SRAM)
 - Supports Interface to Standard Sync Devices and Custom Logic (FPGA, CPLD, ASICs, etc.)
- **Enhanced Direct-Memory-Access (EDMA) Controller (64 Independent Channels)**
- **3-Port Gigabit Ethernet Switch Subsystem**
- **Four 64-Bit General-Purpose Timers (Each Configurable as Two 32-Bit Timers)**
- **One UART (With RTS and CTS Flow Control)**
- **One 4-wire Serial Port Interface (SPI) With Two Chip-Selects**
- **Master/Slave Inter-Integrated Circuit (I2C Bus™)**
- **Multichannel Audio Serial Port (McASP)**
 - Ten Serializers and SPDIF (DIT) Mode
- **16/32-Bit Host-Port Interface (HPI)**
- **Advanced Event Triggering (AET) Compatible**
- **32-Bit 33-/66-MHz, 3.3-V Peripheral Component Interconnect (PCI) Master/Slave Interface Conforms to PCI Specification 2.3**



Please be aware that an important notice concerning availability, standard warranty, and use in critical applications of Texas Instruments semiconductor products and disclaimers thereto appears at the end of this data sheet.

- VLYNQ™ Interface (FPGA Interface)
 - On-Chip ROM Bootloader
 - Individual Power-Saving Modes
 - Flexible PLL Clock Generators
 - IEEE-1149.1 (JTAG™) Boundary-Scan-Compatible
 - 32 General-Purpose I/O (GPIO) Pins
- (Multiplexed With Other Device Functions)
- Package:
 - 529-pin nFBGA (ZUT suffix)
 - 19x19 mm 0.8 mm pitch BGA
 - 0.09- μ m/6-Level Cu Metal Process (CMOS)
 - 3.3-V and 1.8-V I/O, 1.2-V Internal (-720, -800, -900, -1100)

1.1 Applications

- Digital Video Recording

1.2 Trademarks

TMS320C64x+, C64x, C64x+, VelociTI, VelociTI.2, VLYNQ, TMS320C6000, C6000, TI, and TMS320 are trademarks of Texas Instruments.

I2C Bus is a registered trademark of Koninklijke Philips Electronics N.V.

Windows is a registered trademark of Microsoft Corporation in the United States and/or other countries.

All trademarks are the property of their respective owners.

1.3 Description

The TMS320C64x+™ DSPs (including the TMS320DM647/TMS320DM648 devices) are the highest-performance fixed-point DSP generation in the TMS320C6000™ DSP platform. The DM647, DM648 devices are based on the third-generation high-performance, advanced VelociTI™ very-long-instruction-word (VLIW) architecture developed by Texas Instruments (TI), making these DSPs an excellent choice for digital media applications. The C64x+™ devices are upward code-compatible from previous devices that are part of the C6000™ DSP platform. The C64x™ DSPs support added functionality and have an expanded instruction set from previous devices.

Any reference to the C64x DSP or C64x CPU also applies, unless otherwise noted, to the C64x+ DSP and C64x+ CPU, respectively.

With performance of up to 8800 million instructions per second (MIPS) at a clock rate of 1.1 GHz, the C64x+ core offers solutions to high-performance DSP programming challenges. The DSP core possesses the operational flexibility of high-speed controllers and the numerical capability of array processors. The C64x+ DSP core processor has 64 general-purpose registers of 32-bit word length and eight highly independent functional units—two multipliers for a 32-bit result and six arithmetic logic units (ALUs). The eight functional units include instructions to accelerate the performance in video and imaging applications. The DSP core can produce four 16-bit multiply-accumulates (MACs) per cycle for up to 4400 million MACs per second (MMACS), or eight 8-bit MACs per cycle for up to 8800 MMACS. For more details on the C64x+ DSP, see the *TMS320C64x/C64x+ DSP CPU and Instruction Set Reference Guide* (literature number [SPRU732](#)).

The devices also have application-specific hardware logic, on-chip memory, and additional on-chip peripherals similar to the other C6000 DSP platform devices. The core uses a two-level cache-based architecture. The Level 1 program cache (L1P) is a 256K-bit direct mapped cache and the Level 1 data cache (L1D) is a 256K-bit 2-way set-associative cache. The Level 2 memory/cache (L2) consists of a 4M-bit (DM648) or 2M-bit (DM647) memory space that is shared between program and data space. L2 memory can be configured as mapped memory, cache, or combinations of the two.

The peripheral set includes five configurable 16-bit video port peripherals (VP0, VP1, VP2, VP3, and VP4). These video port peripherals provide a glueless interface to common video decoder and encoder devices. The video port peripherals support multiple resolutions and video standards (e.g., CCIR601, ITU-BT.656, BT.1120, SMPTE 125M, 260M, 274M, and 296M), a VCXO interpolated control port (VIC); a 1000 Mbps Ethernet Switch Subsystem with a management data input/output (MDIO) module and two SGMII

ports (DM648) or one SGMII port (only DM647); a 4-bit transmit, 4-bit receive VLYNQ interface; an inter-integrated circuit (I2C) bus interface; a multichannel audio serial port (McASP) with ten serializers; four 64-bit general-purpose timers each configurable as two independent 32-bit timers; a user-configurable 16-bit or 32-bit host-port interface (HPI); 32 pins for general-purpose input/output (GPIO) with programmable interrupt/event generation modes, multiplexed with other peripherals; one UART; and two glueless external memory interfaces: a synchronous and asynchronous external memory interface (EMIFA) for slower memories/peripherals, and a higher DDR2 SDRAM interface.

The video port peripherals provide a glueless interface to common video decoder and encoder devices. The video port peripherals support multiple resolutions and video standards (e.g., CCIR601, ITU-BT.656, BT.1120, SMPTE 125M, 260M, 274M, and 296M).

The video port peripherals are configurable and can support either video capture and/or video display modes. Each video port consists of two channels (A and B) with a 5120-byte capture/display buffer that is splittable between the two channels.

For more details on the video port peripherals, see the *TMS320DM647/DM648 Video Port User's Guide* (literature number [SPRUEM1](#)).

The management data input/output (MDIO) module continuously polls all 32 MDIO addresses to enumerate all PHY devices in the system.

The I2C and VLYNQ ports allow the device to easily control peripheral modules and/or communicate with host processors.

The rich peripheral set provides the ability to control external peripheral devices and communicate with external processors. For details on each of the peripherals, see the related sections later in this document and the associated peripheral reference guides.

The devices have a complete set of development tools. These include C compilers, a DSP assembly optimizer to simplify programming and scheduling, and a Windows™ debugger interface for visibility into source code execution.

1.4 Functional Block Diagram

Figure 1-1 shows the functional block diagram of the device.

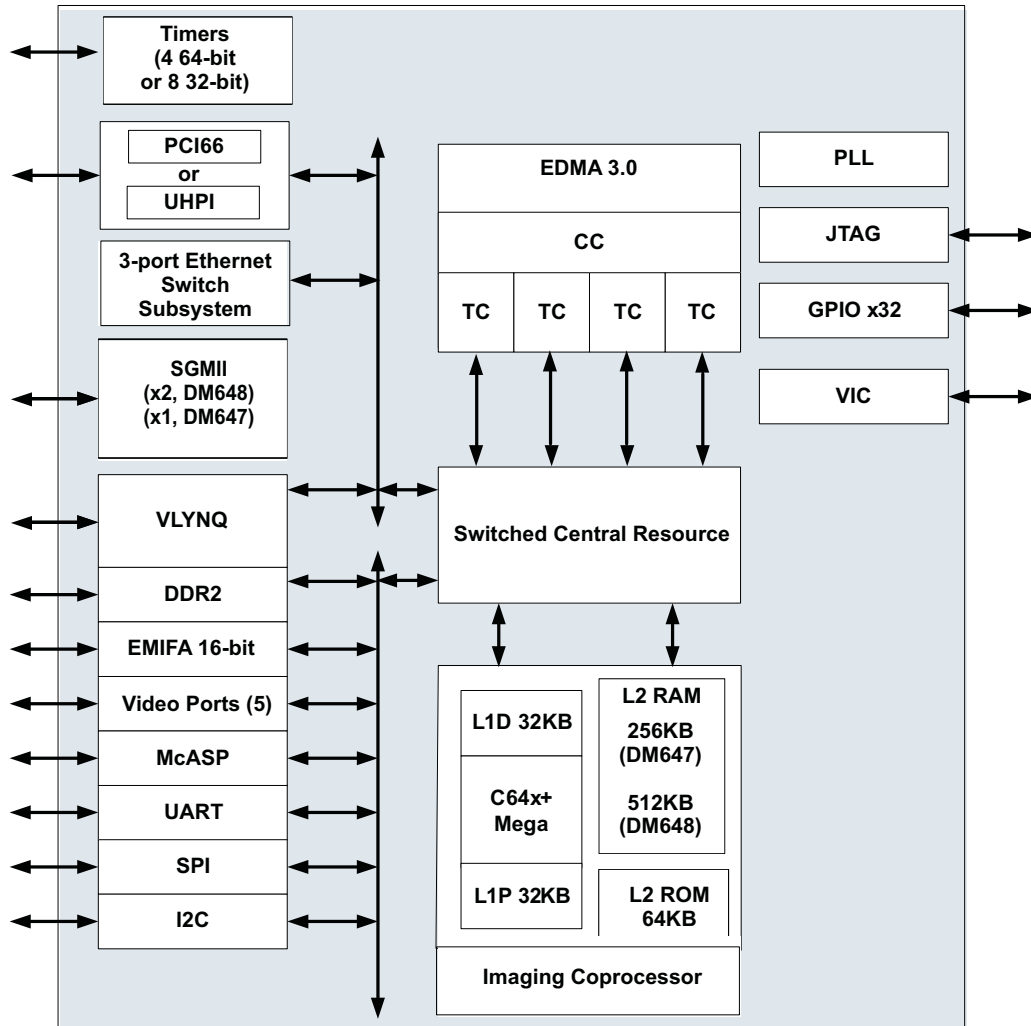

Figure 1-1. Functional Block Diagram

1	Features	1	6.2	Recommended Clock and Control Signal Transition Behavior	59
1.1	Applications	2	6.3	Power Supplies	59
1.2	Trademarks	2	6.4	PLL1 Controller	65
1.3	Description	2	6.5	PLL2 Controller	69
1.4	Functional Block Diagram	4	6.6	Enhanced Direct Memory Access (EDMA3) Controller	71
Revision History		6	6.7	Reset Controller	84
2	Device Overview	7	6.8	Interrupts	96
2.1	Device Characteristics	7	6.9	DDR2 Memory Controller	100
2.2	CPU (DSP Core) Description	8	6.10	External Memory Interface A (EMIFA)	111
2.3	C64x+ CPU	11	6.11	Video Port	118
2.4	Memory Map Summary	12	6.12	VCXO Interpolated Control (VIC)	126
2.5	Pin Assignments	16	6.13	Universal Asynchronous Receiver/Transmitter (UART)	128
2.6	Terminal Functions	20	6.14	Serial Peripheral Interface Port (SPI)	130
2.7	Device Support	34	6.15	Inter-Integrated Circuit (I2C)	134
3	Device Configuration	38	6.16	Host-Port Interface (HPI) Peripheral	138
3.1	System Module Registers	38	6.17	Peripheral Component Interconnect (PCI)	149
3.2	Bootmode Registers	39	6.18	Multichannel Audio Serial Port (McASP)	154
3.3	Pullup/Pulldown Resistors	49	6.19	3-Port Ethernet Switch Subsystem (3PSW)	162
4	System Interconnect	50	6.20	Management Data Input/Output (MDIO)	172
4.1	Internal Buses, Bridges, and Switch Fabrics	50	6.21	Timers	173
4.2	Data Switch Fabric Connections	50	6.22	VLYNQ Peripheral	175
4.3	Configuration Switch Fabric	52	6.23	General-Purpose Input/Output (GPIO)	178
5	Device Operating Conditions	54	6.24	Emulation Features and Capability	180
5.1	Absolute Maximum Ratings	54	6.25	IEEE 1149.1 JTAG	181
5.2	Recommended Operating Conditions	55	7	Mechanical Data	183
5.3	Electrical Characteristics	56	7.1	Thermal Data for ZUT	183
6	Peripheral Information and Electrical Specifications	57	7.2	Packaging Information	184
6.1	Parameter Information	57			

Revision History

NOTE: Page numbers for previous revisions may differ from page numbers in the current version.

This data manual revision history highlights the technical changes made to the SPRS372G device-specific data manual to make it an SPRS372H revision. Applicable updates to the TMS320DM64x Digital Media Processors device family, specifically relating to the TMS320DM647, TMS320DM648 devices which are now in the production data (PD) stage of development, have been incorporated.

DM647/DM648 Revision History

SEE	ADDITIONS, DELETIONS, MODIFICATIONS
Section 1	External Memory Interfaces (EMIFs): <ul style="list-style-type: none"> Deleted the footnote reference (1) from "512M-Byte Address Space (1.8-V I/O)" subbullet Deleted associated footnote [devices are PD; SR1.0 was TMX]
Section 1.1	Added separate Applications section (new format structure)
Table 2-4	Terminal Functions, Power Pins: <ul style="list-style-type: none"> Added "or left unconnected" to the V_{CCMON} (L19) pin DESCRIPTION column [For the Advisory, see the Device-Specific Silicon Errata.]
Figure 6-5	Corrected CLKDIR to VLYNQ to show 0 is VLYNQ, external
Section 6.4.1	PLL1 Controller Device-Specific Information <ul style="list-style-type: none"> Added "[When SYSCLK4 is used as the EMIF input clock source, the actual clock goes through a divider and the frequency would be SYSCLK4 divide-by-2 (see Figure 6-5, PLL Input Clock.)]" to the <i>SYSCLK4 is used as the EMIFA AECLKOUT</i> bullet [Cleared Doc Feedback]
Table 6-44	Timing Requirements for Asynchronous Memory Cycles for EMIFA Module: <ul style="list-style-type: none"> Changed 3ns to 0ns for t_h(AOEH-EDV)
Figure 6-21	Updated to show times 3 and 4 are referred to rising edge $\overline{AAOE}/\overline{ASOE}$.
Table 6-49	Changed 5.4ns to 4.2ns for t _w (VKIH) and t _w (VKIL).
Section 7.2	Deleted duplicated Orderable Addendum table

2 Device Overview

2.1 Device Characteristics

Table 2-1, provides an overview of the DSP. The tables show significant features of the devices, including the capacity of on-chip RAM, the peripherals, the CPU frequency, and the package type with pin count.

Table 2-1. Characteristics of the Processor

HARDWARE FEATURES		DM647	DM648
Peripherals Not all peripheral pins are available at the same time (For more detail, see Section 3.)	DDR2 memory controller (32-bit bus width) [1.8 V I/O]	1	1
	16-bit bus width synchronous/asynchronous EMIF [EMIFA]	1	1
	EDMA3 (64 independent channels, 8 QDMA channels)	1	1
	Timers	4 64-bit General Purpose (each configurable as 1 64-bit or 2 32-bit)	4 64-bit General Purpose (each configurable as 1 64-bit or 2 32-bit)
	UART	(with RTS and CTS flow control)	(with RTS and CTS flow control)
	I2C	1 (Master/Slave)	1 (Master/Slave)
	SPI	1 (4-wire, 2 chip select)	1 (4-wire, 2 chip select)
	McASP	1 (10 serializers)	1 (10 serializers)
	3-port Ethernet Switch Subsystem supporting 10/100/1000 Base-T Management data input/output (MDIO)	1 SGMII port available	2 SGMII ports available
	VLINQ	1	1
	General-purpose input/output port (GPIO)	Up to 32 pins	Up to 32 pins
	HPI (16/32-bit)	1	1
	PCI (32 bit) (33 MHz or 66 MHz)	1 (PCI33 or PCI66)	1 (PCI33 or PCI66)
	VIC	1	1
	Configurable video ports	5	5
On-Chip Memory	Size (bytes)	320KB RAM, 64KB ROM	576KB RAM, 64KB ROM
	Organization	32KB L1 program (L1P)/cache (up to 32KB) 32KB L1 data (L1D)/cache (up to 32KB) 256KB unified mapped RAM/Cache (L2) 64KB Boot ROM	32KB L1 program (L1P)/cache (up to 32KB) 32KB L1 data (L1D)/cache (up to 32KB) 512 KB unified mapped RAM/Cache (L2) 64KB Boot ROM
MegaModule Rev ID	Revision ID Register (MM_REVID[15:0]) (address location 0x0181 2000)	0x0003	0x0003
CPU ID + CPU Rev ID	Control Status Register (CSR.[31:16])	0x1000	0x1000
JTAG BSDL_ID	JTAGID register (address location: 0x0204 9018)	0x1B77 A02F	0x1B77 A02F
CPU Frequency	MHz	720, 900, 1100	720, 800, 900, 1100
Cycle Time	ns	1.39 ns (-720)	1.39 ns (-720)
		1.11 ns (-900)	1.25 ns (-800)
		0.91 ns (-1100)	1.11 ns (-900)
			0.91 ns (-1100)
Voltage	Core (V)	1.2 V (-720, -900, -1100)	1.2 V (-720, -800, -900, -1100)
	I/O (V)	1.8 V, 3.3 V	1.8 V, 3.3 V

Table 2-1. Characteristics of the Processor (continued)

HARDWARE FEATURES		DM647	DM648
PLL Options	CLKIN1 frequency multiplier	x1 (Bypass), PLLM = 15, 16, ..., 31 (x16, x17, ..., x32) ⁽¹⁾	x1 (Bypass), PLLM = 15, 16, ..., 31 (x16, x17, ..., x32) ⁽¹⁾
BGA Package		529-Pin Flip Chip Plastic BGA (ZUT)	529-Pin Flip Chip Plastic BGA (ZUT)
Process Technology	0.09- μ m/6-Level Cu Metal Process (CMOS)	0.09 μ m	0.09 μ m
Product Status ⁽²⁾	Production Data (PD)	PD	PD

(1) The maximum CPU frequency must not be violated.
(2) See [Section 2.7](#) for a description of each stage of development.

2.2 CPU (DSP Core) Description

The C64x+ central processing unit (CPU) consists of eight functional units, two register files, and two data paths as shown in [Figure 2-1](#). The two general-purpose register files (A and B) each contain 32 32-bit registers for a total of 64 registers. The general-purpose registers can be used for data or can be data address pointers. The data types supported include packed 8-bit data, packed 16-bit data, 32-bit data, 40-bit data, and 64-bit data. Values larger than 32 bits, such as 40-bit-long or 64-bit-long values are stored in register pairs, with the 32 LSBs of data placed in an even register and the remaining 8 or 32 MSBs in the next upper register (which is always an odd-numbered register).

The eight functional units (.M1, .L1, .D1, .S1, .M2, .L2, .D2, and .S2) are each capable of executing one instruction every clock cycle. The .M functional units perform all multiply operations. The .S and .L units perform a general set of arithmetic, logical, and branch functions. The .D units primarily load data from memory to the register file and store results from the register file into memory.

The C64x+ CPU extends the performance of the C64x core through enhancements and new features.

Each C64x+ .M unit can perform one of the following each clock cycle: one 32 x 32 bit multiply, one 16 x 32 bit multiply, two 16 x 16 bit multiplies, two 16 x 32 bit multiplies, two 16 x 16 bit multiplies with add/subtract capabilities, four 8 x 8 bit multiplies, four 8 x 8 bit multiplies with add operations, and four 16 x 16 multiplies with add/subtract capabilities (including a complex multiply). There is also support for Galois field multiplication for 8-bit and 32-bit data. Many communications algorithms such as FFTs and modems require complex multiplication. The complex multiply (CMPY) instruction takes for 16-bit inputs and produces a 32-bit real and a 32-bit imaginary output. There are also complex multiplies with rounding capability that produces one 32-bit packed output that contain 16-bit real and 16-bit imaginary values. The 32 x 32 bit multiply instructions provide the extended precision necessary for audio and other high-precision algorithms on a variety of signed and unsigned 32-bit data types.

The .L or (Arithmetic Logic Unit) now incorporates the ability to do parallel add/subtract operations on a pair of common inputs. Versions of this instruction exist to work on 32-bit data or on pairs of 16-bit data performing dual 16-bit add and subtracts in parallel. There are also saturated forms of these instructions.

The C64x+ core enhances the .S unit in several ways. In the C64x core, dual 16-bit MIN2 and MAX2 comparisons were available only on the .L units. On the C64x+ core they are also available on the .S unit, which increases the performance of algorithms that do searching and sorting. Finally, to increase data packing and unpacking throughput, the .S unit allows sustained high performance for the quad 8-bit/16-bit and dual 16-bit instructions. Unpack instructions prepare 8-bit data for parallel 16-bit operations. Pack instructions return parallel results to output precision including saturation support.

Other new features include:

- **SPLOOP** - A small instruction buffer in the CPU that aids in creation of software pipelining loops where multiple iterations of a loop are executed in parallel. The SPLOOP buffer reduces the code size associated with software pipelining. Furthermore, loops in the SPLOOP buffer are fully interruptible.

- **Compact Instructions** - The native instruction size for the C6000 devices is 32 bits. Many common instructions such as MPY, AND, OR, ADD, and SUB can be expressed as 16 bits if the C64x+ compiler can restrict the code to use certain registers in the register file. This compression is performed by the code generation tools.
- **Instruction Set Enhancement** - As noted above, there are new instructions such as 32-bit multiplications, complex multiplications, packing, sorting, bit manipulation, and 32-bit Galois field multiplication.
- **Exceptions Handling** - Intended to aid the programmer in isolating bugs. The C64x+ CPU is able to detect and respond to exceptions, both from internally detected sources (such as illegal opcodes).
- **Privilege** - Defines user and supervisor modes of operation, allowing the operating system to give a basic level of protection to sensitive resources. Local memory is divided into multiple pages, each with read, write, and execute permissions.
- **Time-Stamp Counter** - Primarily targeted for real-time operating system (RTOS) robustness, a free-running time-stamp counter that is *not* sensitive to system stalls is implemented in the CPU.

For more details on the C64x+ CPU and its enhancements over the C64x architecture, see the following documents:

- *TMS320C64x/C64x+ DSP CPU and Instruction Set Reference Guide* (literature number [SPRU732](#))
- *TMS320C64x+ DSP Megamodule Reference Guide* (literature number [SPRU871](#))
- *TMS320C64x to TMS320C64x+ CPU Migration Guide Application Report* (literature number [SPRAA84](#))
- *TMS320C64x+ DSP Cache User's Guide* (literature number [SPRU862](#))

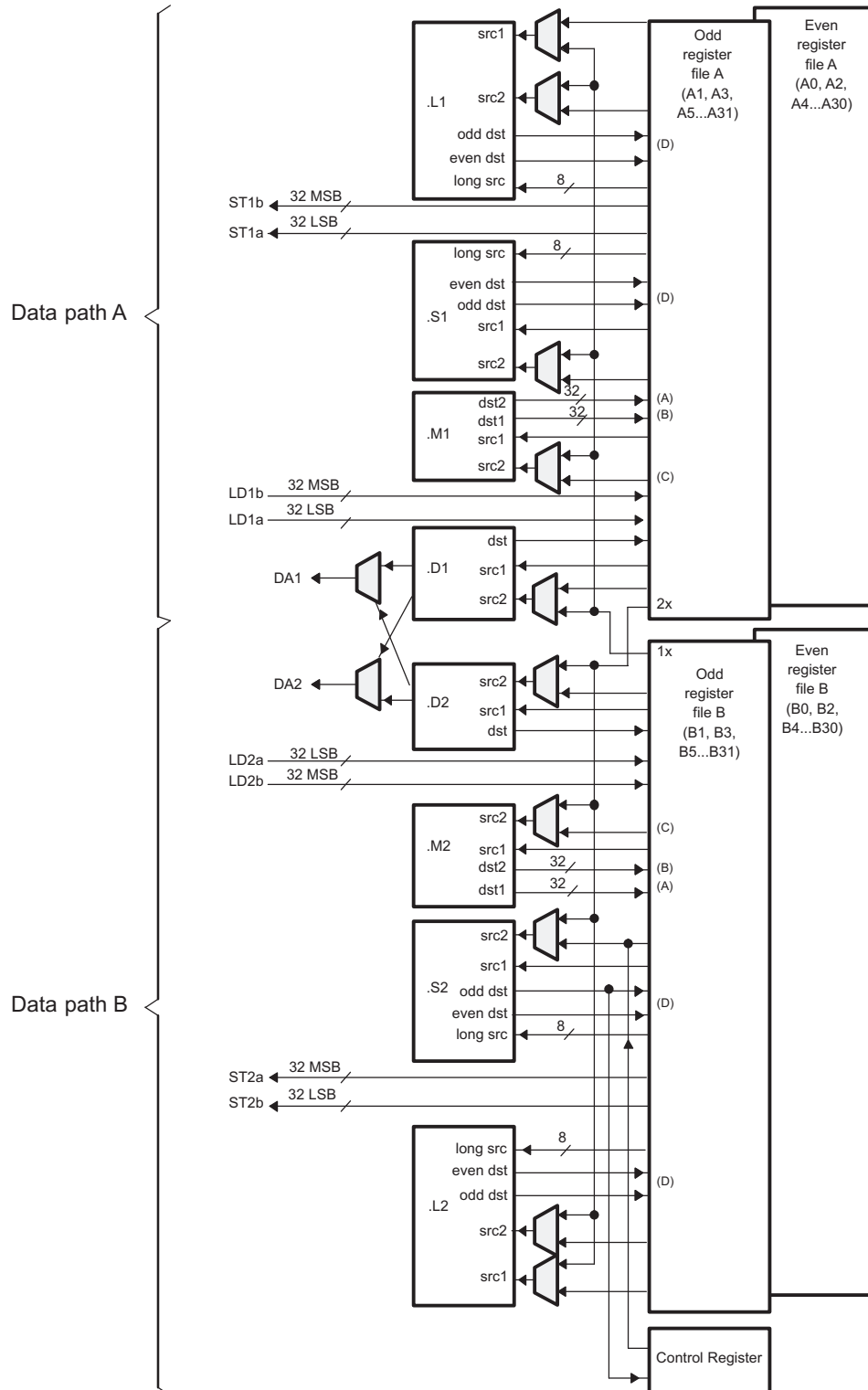

- A. On .M unit, dst2 is 32 MSB.
- B. On .M unit, dst1 is 32 LSB.
- C. On C64x CPU .M unit, src2 is 32 bits; on C64x+ CPU .M unit, src2 is 64 bits.
- D. On .L and .S units, odd dst connects to odd register files and even dst connects to even register files.

Figure 2-1. TMS320C64x+™ CPU (DSP Core) Data Paths

2.3 C64x+ CPU

The C64x+ core uses a two-level cache-based architecture. The Level 1 program memory/cache (L1P) consists of 32KB memory space that can be configured as mapped memory or direct mapped cache. The Level 1 data memory/cache (L1D) consists of 32KB that can be configured as mapped memory or 2-way associated cache. The Level 2 memory/cache (L2) consists of a 256KB (DM647)/512 KB (DM648) memory space that is shared between program and data space. L2 memory can be configured as mapped memory, cache, or a combination of both.

Table 2-2 shows a memory map of the C64x+ CPU cache registers for the device.

Table 2-2. C64x+ Cache Registers

HEX ADDRESS RANGE	REGISTER ACRONYM	DESCRIPTION
0x0184 0000	L2CFG	L2 cache configuration register
0x0184 0020	L1PCFG	L1P size cache configuration register
0x0184 0024	L1PCC	L1P freeze mode cache configuration register
0x0184 0040	L1DCFG	L1D size cache configuration register
0x0184 0044	L1DCC	L1D freeze mode cache configuration register
0x0184 0048 - 0x0184 0FFC	-	Reserved
0x0184 1000	-	Reserved
0x0184 1004 - 0x0184 1FFC	-	Reserved
0x0184 2000	L2ALLOC0	L2 allocation register 0
0x0184 2004	L2ALLOC1	L2 allocation register 1
0x0184 2008	L2ALLOC2	L2 allocation register 2
0x0184 200C	L2ALLOC3	L2 allocation register 3
0x0184 2010 - 0x0184 3FFF	-	Reserved
0x0184 4000	L2WBAR	L2 writeback base address register
0x0184 4004	L2WWC	L2 writeback word count register
0x0184 4010	L2WIBAR	L2 writeback invalidate base address register
0x0184 4014	L2WIWC	L2 writeback invalidate word count register
0x0184 4018	L2IBAR	L2 invalidate base address register
0x0184 401C	L2IWC	L2 invalidate word count register
0x0184 4020	L1PIBAR	L1P invalidate base address register
0x0184 4024	L1PIWC	L1P invalidate word count register
0x0184 4030	L1DWIBAR	L1D writeback invalidate base address register
0x0184 4034	L1DWIWC	L1D writeback invalidate word count register
0x0184 4038	-	Reserved
0x0184 4040	L1DWBAR	L1D block writeback
0x0184 4044	L1DWWC	L1D block writeback
0x0184 4048	L1DIBAR	L1D invalidate base address register
0x0184 404C	L1DIWC	L1D invalidate word count register
0x0184 4050 - 0x0184 4FFF	-	Reserved
0x0184 5000	L2WB	L2 writeback all register
0x0184 5004	L2WBINV	L2 writeback invalidate all register
0x0184 5008	L2INV	L2 global invalidate without writeback
0x0184 500C - 0x0184 5027	-	Reserved
0x0184 5028	L1PINV	L1P global invalidate
0x0184 502C - 0x0184 5039	-	Reserved
0x0184 5040	L1DWB	L1D global writeback
0x0184 5044	L1DWBINV	L1D global writeback with invalidate
0x0184 5048	L1DINV	L1D global invalidate without writeback

Table 2-2. C64x+ Cache Registers (continued)

HEX ADDRESS RANGE	REGISTER ACRONYM	DESCRIPTION
0x0184 8000 - 0x0184 80FC	MAR0 - MAR63	Reserved 0x0000 0000 - 0x3FFF FFFF
0x0184 80C0 - 0x0184 80FC	MAR48 - MAR63	Reserved 0x3000 0000 - 0x3FFF FFFF
0x0184 8100 - 0x0184 813C	MAR64 - MAR79	Memory attribute registers for PCI Data 0x4000 0000 - 0x4FFF FFFF
0x0184 8140 - 0x0184 827C	MAR80 - MAR159	Reserved 0x5000 0000 - 0x9FFF FFFF
0x0184 8280 - 0x0184 82BC	MAR160 - MAR175	Memory attribute registers for EMIFA CE2 0xA000 0000 - 0xA3FF FFFF
0x0184 82C0 - 0x0184 82FC	MAR176 - MAR191	Memory attribute registers for EMIFA CE3 0xB000 0000 - 0xB3FF FFFF
0x0184 8130 - 0x0184 813C	MAR76 - MAR79	Memory Attribute Registers for VLYNQ 0x4C00 0000 - 0x4FFF FFFF
0x0184 8300 - 0x0184 837C	MAR192 - MAR223	Reserved 0xC000 0000 - 0xDFFF FFFF
0x0184 8380 - 0x0184 83BC	MAR224 - MAR239	Memory attribute registers for DDR2 0xE000 0000 - 0xEFFF FFFF
0x0184 83C0 - 0x0184 83FC	MAR240 - MAR255	Memory attribute registers for DDR2 0xF000 0000 - 0xFFFF FFFF

2.4 Memory Map Summary

Table 2-3 shows the memory map address ranges of the device. The device has multiple on-chip memories associated with its processor and various subsystems. To help simplify software development, a unified memory map is used where possible to maintain a consistent view of device resources across all bus masters.

Table 2-3. Memory Map Summary

START ADDRESS	END ADDRESS	SIZE (Bytes)	C64x+ MEMORY MAP
0x0000 0000	0x000F FFFF	1M	Reserved
0x0010 0000	0x0011 FFFF	128K	VICP
0x0020 0000	0x007F FFFF	6M	Reserved
0x0080 0000	0x008B FFFF	768K	Internal ROM
0x008C 0000	0x009F FFFF	2M - 768K	Reserved
0x00A0 0000	0x00A3 FFFF	256K	L2 SRAM (for both DM647 and DM648)
0x00A4 0000	0x00A7 FFFF	256K	L2 SRAM (for DM648 only)
0x00A8 0000	0x00DF FFFF	4M - 512K	Reserved
0x00E0 0000	0x00E0 7FFF	32K	L1P SRAM
0x00E0 8000	0x00EF FFFF	1M – 32K	Reserved
0x00F0 0000	0x00F0 7FFF	32K	L1D SRAM
0x00F0 8000	0x00FF FFFF	1M – 32K	Reserved
0x0100 0000	0x017F FFFF	8M	Reserved
0x0180 0000	0x0180 FFFF	64K	C64x+ Interrupt Controller
0x0181 0000	0x0181 0FFF	4K	C64x+ Power-down Control
0x0181 1000	0x0181 1FFF	4K	C64x+ Security ID
0x0181 2000	0x0181 2FFF	4K	C64x+ Revision ID
0x0181 3000	0x0181 FFFF	52K	Reserved
0x0182 0000	0x0182 040F	1040B	C64x+ EMC
0x0182 0410	0x0182 FFFF	64K – 16	Reserved
0x0183 0000	0x0183 FFFF	64K	Reserved
0x0184 0000	0x0184 FFFF	64K	C64x+ Memory control
0x0185 0000	0x01BB FFFF	3, 520K	Reserved
0x01BC 0000	0x01BC FFFF	64K	Emulation
0x01BD 0000	0x01BD FFFF	64K	Reserved
0x01BE 0000	0x01BF FFFF	128K	Reserved
0x01BE 0000	0x01FF FFFF	4.125M	Reserved
0x0200 0000	0x0200 007F	128B	HPI Control
0x0200 0080	0x0203 FFFF	256K – 128	Reserved
0x0204 0000	0x0204 3FFF	16K	McASP Control

Table 2-3. Memory Map Summary (continued)

START ADDRESS	END ADDRESS	SIZE (Bytes)	C64x+ MEMORY MAP
0x0204 4000	0x0204 43FF	1K	McASP Data
0x0204 4400	0x0204 47FF	1K	Timer0
0x0204 4800	0x0204 4BFF	1K	Timer1
0x0204 4C00	0x0204 4FFF	1K	Timer2
0x0204 5000	0x0204 53FF	1K	Timer3
0x0204 5400	0x0204 5FFF	3K	Reserved
0x0204 6000	0x0204 6FFF	4K	PSC
0x0204 7000	0x0204 73FF	1K	UART
0x0204 7400	0x0204 77FF	1K	VIC Control
0x0204 7800	0x0204 7BFF	1K	SPI
0x0204 7C00	0x0204 7FFF	1K	I2C Data and Control
0x0204 8000	0x0204 83FF	1K	GPIO
0x0204 8400	0x0204 87FF	1K	PCI Control
0x0204 8800	0x0204 8FFF	2K	Reserved
0x0204 9000	0x0204 9FFF	4K	Chip-Level Registers
0x0204 A000	0x0207 FFFF	216K	Reserved
0x0208 0000	0x0209 FFFF	128K	VICP Configuration
0x020A 0000	0x020D FFFF	256K	Reserved
0x020E 0000	0x020E 01FF	512	PLL Controller 1
0x020E 0200	0x0211 FFFF	256K – 512	Reserved
0x0212 0000	0x0212 01FF	512	PLL Controller 2
0x0212 0200	0x0215 FFFF	256K – 512	Reserved
0x0216 0000	0x029C FFFF	9M - 576K	Reserved
0x02A0 0000	0x02A0 7FFF	32K	EDMA3CC
0x02A0 8000	0x02A1 FFFF	96K	Reserved
0x02A2 0000	0x02A2 7FFF	32K	EDMA3TC0
0x02A2 8000	0x02A2 FFFF	32K	EDMA3TC1
0x02A3 0000	0x02A3 7FFF	32K	EDMA3TC2
0x02A3 8000	0x02A3 FFFF	32K	EDMA3TC3
0x02A4 0000	0x02A7 FFFF	256K	Reserved
0x02A8 0000	0x02A8 04FF	1.25K	Reserved
0x02A8 0500	0x02AB FFFF	256K – 1.25K	Reserved
0x02AC 0000	0x02AD FFFF	128K	Reserved
0x02AE 0000	0x02AF FFFF	128K	Reserved
0x02B0 0000	0x02B0 00FF	256	Reserved
0x02B0 0100	0x02B0 3FFF	16K – 256	Reserved
0x02B0 4000	0x02B0 407F	128	Reserved
0x02B0 4080	0x02B3 FFFF	256K – 128	Reserved
0x02B4 0000	0x02B4 01FF	512	Reserved
0x02B4 0200	0x02B7 FFFF	256K – 512	Reserved
0x02B8 0000	0x02B9 FFFF	128K	Reserved
0x02BA 0000	0x02BB FFFF	128K	Reserved
0x02BC 0000	0x02BF FFFF	256K	Reserved
0x02C0 0000	0x02C0 3FFF	16K	VP0 Control
0x02C0 4000	0x02C0 7FFF	16K	VP1 Control
0x02C0 8000	0x02C0 BFFF	16K	VP2 Control
0x02C0 C000	0x02C0 FFFF	16K	VP3 Control
0x02C1 0000	0x02C1 3FFF	16K	VP4 Control
0x02C1 4000	0x02C3 FFFF	176K	Reserved
0x02C4 0000	0x02C7 FFFF	256K	Reserved
0x02C8 0000	0x02CB FFFF	256K	Reserved

Table 2-3. Memory Map Summary (continued)

START ADDRESS	END ADDRESS	SIZE (Bytes)	C64x+ MEMORY MAP
0x02CC 0000	0x02CF FFFF	256K	Reserved
0x02D0 0000	0x02D0 1FFF	8K	Ethernet Subsystem CPPI RAM ⁽¹⁾
0x02D0 2000	0x02D0 2FFF	4K	Ethernet Subsystem Control
0x02D0 3000	0x02D0 3FFF	4K	Ethernet Subsystem 3PSW
0x02D0 4000	0x02D0 47FF	2K	Ethernet Subsystem MDIO
0x02D0 4800	0x02D0 4BFF	1K	Ethernet Subsystem SGMII0
0x02D0 4C00	0x02D0 4FFF	1K	Ethernet Subsystem SGMII1 (DM648 only)
0x02D0 5000	0x02D0 57FF	2K	Reserved
0x02D0 5800	0x02DB FFFF	746K	Reserved
0x02DC 0000	0x02DF FFFF	256K	Reserved
0x02E0 0000	0x02E0 3FFF	16K	Reserved
0x02E0 4000	0x02FF FFFF	2M – 16K	Reserved
0x0300 0000	0x03FF FFFF	16M	Reserved
0x0400 0000	0x0FFF FFFF	192M	Reserved
0x1000 0000	0x1FFF FFFF	256M	Reserved
0x2000 0000	0x2FFF FFFF	256M	Reserved
0x3000 0000	0x3000 00FF	256	Reserved
0x3000 0100	0x33FF FFFF	64M – 256	Reserved
0x3400 0000	0x3400 00FF	256	Reserved
0x3400 0100	0x37FF FFFF	64M – 256	Reserved
0x3800 0000	0x3BFF FFFF	64M	VLYNQ
0x3C00 0000	0x3CFF FFFF	16M	Reserved
0x3D00 0000	0x3DFF FFFF	16M	Reserved
0x3E00 0000	0x3FFF FFFF	32M	Reserved
0x4000 0000	0x4FFF FFFF	256M	PCI Data
0x5000 0000	0x51FF FFFF	32M	VP0 ChannelA Data
0x5200 0000	0x53FF FFFF	32M	VP0 ChannelB Data
0x5400 0000	0x55FF FFFF	32M	VP1 ChannelA Data
0x5600 0000	0x57FF FFFF	32M	VP1 ChannelB Data
0x5800 0000	0x59FF FFFF	32M	VP2 ChannelA Data
0x5A00 0000	0x5BFF FFFF	32M	VP2 ChannelB Data
0x5C00 0000	0x5DFF FFFF	32M	Reserved
0x5E00 0000	0x5FFF FFFF	32M	Reserved
0x6000 0000	0x61FF FFFF	32M	VP3 ChannelA Data
0x6200 0000	0x63FF FFFF	32M	VP3 ChannelB Data
0x6400 0000	0x65FF FFFF	32M	VP4 ChannelA Data
0x6600 0000	0x67FF FFFF	32M	VP4 ChannelB Data
0x6800 0000	0x6FFF FFFF	128M	Reserved
0x7000 0000	0x77FF FFFF	128M	EMIFA Configuration
0x7800 0000	0x7FFF FFFF	128M	DDR2 EMIF Configuration
0x8000 0000	0x8FFF FFFF	256M	Reserved
0x9000 0000	0x9FFF FFFF	256M	Reserved
0xA000 0000	0xA3FF FFFF	64M	EMIFA CE2 ⁽²⁾
0xA400 0000	0xAFFF FFFF	256 - 64M	Reserved
0xB000 0000	0xB3FF FFFF	64M	EMIFA CE3 ⁽²⁾
0xB400 0000	0xBFFF FFFF	256 - 64M	Reserved
0xC000 0000	0xCFFF FFFF	256M	Reserved

- (1) The 8K CPPI Descriptor memory is mapped to an address range 0x02C8 2000 - 0x02C8 3FFF, from the perspective of the Ethernet subsystem 3PSW. The buffer descriptors, when accessed from the C64x+, are addressed from 0x02D0 0000. However, within these buffer descriptors, when the pointer to the next buffer descriptor is programmed, the Ethernet subsystem 3PSW is interpreting this value. Thus, this programmed value should be in the address range starting from 0x02C8 2000.
- (2) The EMIFA CS0 and CS1 are **not** functionally supported; therefore, they are **not** pinned out.

Table 2-3. Memory Map Summary (continued)

START ADDRESS	END ADDRESS	SIZE (Bytes)	C64x+ MEMORY MAP
0xD000 0000	0xDFFF FFFF	256M	Reserved
0xE000 0000	0xEFFF FFFF	256M	DDR2 SDRAM
0xF000 0000	0xFFFF FFFF	256M	DDR2 SDRAM

2.5 Pin Assignments

Extensive use of pin multiplexing is used to accommodate the largest number of peripheral functions in the smallest possible package. Pin multiplexing is controlled using a combination of hardware configuration at device reset and software programmable register settings. For more information on pin muxing, see [Section 3.2.6, PINMUX Register](#).

2.5.1 Pin Map (Bottom View)

Figure 2-2 through Figure 2-5 show the bottom view of the ZUT package pin assignments in four quadrants (A, B, C, and D).

	1	2	3	4	5	6	7	8	9	10	11	12
AC	V _{SS}	D _{VDD33}	AHCLKX	AHCLKR	D _{VDD33}	ACLKR	ACLKX	V _{SS}	SGMII1RXN	V _{SS}	REFCLKN	V _{SS}
AB	VP2CLK0	VP2CTL1	AMUTEIN	AXR3	V _{SS}	AXR0	D _{VDD33}	A _{VDDT}	SGMII1RXP	A _{VDDR}	REFCLKP	D _{VDD33}
AA	VP2CTL0	VP2D03	V _{SS}	AXR6	VDAC/ AXR9	AXR2	AFSX	V _{SS}	SGMII0RXP	SGMII0RXN	V _{SS}	PREQ/ GP03
Y	VP2CTL2/ VSCRUN	VP2D06	VP2D04	D _{VDD33}	AXR4	AXR1	STCLK/ AXR8	D _{VDD33}	V _{SS}	V _{SS}	SGMII0TXP	RSV21
W	VP2CLK1/ VCLK	VP2D12/ VRXD0	VP2D07	VP2D09	VP2D02	AFSR	V _{SS}	SGMII1TXP	SGMII1TXN	A _{VDDA}	SGMII0TXN	RSV22
V	V _{SS}	D _{VDD33}	VP2D13/ /VRXD1	VP2D14/ VRXD2	VP2D08	AXR7	AXR5	C _{VDD}	V _{SS}	RSV17	A _{VDDA}	PINTA/ GP02
U	VP2D15/ VRXD3	VP2D17/ VTXD1	VP2D16/ VTXD0	VP2D19/ VTXD3	VP2D18/ VTXD2	VP2D05	AMUTE	MDIO	MDCLK	D _{VDD}	A _{VDDT}	PRST/ GP01
T	VP3CLK0/ AECLKIN	VP3CTL0/ AAWE/ASWE	VP3D05/ AED03	VP3D04/ AED02	VP3D03/ AED01	VP3D02/ AED00	V _{SS}	D _{VDD33}	V _{SS}	D _{VDD}	V _{SS}	D _{VDD33}
R	VP3CTL1/ AR/W	VP3D12/ AED08	VP3D09/ AED07	VP3D08/ AED06	VP3D07/ AED05	VP3D06/ AED04	D _{VDD33}	C _{VDD}	C _{VDD}	V _{SS}	C _{VDD}	V _{SS}
P	VP3CLK1/ AECLKOUT	VP3CTL2/ AAOE/ASOE	VP3D16/ AED12	VP3D15/ AED11	VP3D14/ AED10	VP3D13/ AED09	V _{SS}	D _{VDD33}	V _{SS}	C _{VDD}	V _{SS}	C _{VDD}
N	V _{SS}	D _{VDD33}	PLL1	VP3D17/ AED13	VP3D19/ AED15	VP3D18/ AED14	D _{VDD33}	V _{SS}	C _{VDD}	V _{SS}	C _{VDD}	V _{SS}
M	CLKIN1	RSV9	SYSCLK5	VP4D03/ ABE01	VP4D04/ AEA10	VP4D05	V _{SS}	D _{VDD33}	V _{SS}	C _{VDD}	V _{SS}	C _{VDD}

Figure 2-2. ZUT Pin Map [Top Left Quadrant]

	13	14	15	16	17	18	19	20	21	22	23	
	AD26/ HD26	AD22/ HD22	PCLK/ HHWIL	V _{SS}	$\overline{\text{PCBE1}}/HDS2$	AD14/ HD14	D _{VDD33}	$\overline{\text{PCBE0}}/GP04$	AD02/ HD02	AD04/ HD04	D _{VDD33}	AC
	AD27/ HD27	AD23/ HD23	AD17/ HD17	D _{VDD33}	$\overline{\text{PIRDY}}/HRDY$	AD12/ HD12	V _{SS}	AD08/ HD08	AD05/ HD05	AD01/ HD01	V _{SS}	AB
	AD28/ HD28	PIDSEL/ GP06	AD18/ HD18	$\overline{\text{PFRAME}}/HINT$	$\overline{\text{PTRDY}}/GP05$	AD15/ HD15	AD13/ HD13	AD09/ HD09	AD06/ HD06	AD00/ HD00	AD03/ HD03	AA
	AD29/ HD29	$\overline{\text{PCBE3}}/GP07$	AD19/ HD19	AD16/ HD16	$\overline{\text{PDEVSEL}}/HCNTL1$	$\overline{\text{PSTOP}}/HCNTL0$	AD11/ HD11	AD10/ HD10	AD07/ HD07	VP0CTL0	VP0CLK0	Y
	AD30/ HD30	AD24/ HD24	AD20/ HD20	$\overline{\text{PCBE2}}/HR/W$	$\overline{\text{PPERR}}/HCS$	$\overline{\text{PSERR}}/HDS1$	PPAR/ HAS	VP0D02	VP0D06	V _{SS}	D _{VDD33}	W
	AD31/ HD31	AD25/ HD25	AD21/ HD21	D _{VDD33}	V _{SS}	VP0D03	VP0D05	VP0D09	VP0D12/ GP12	VP0CTL1	VP0CLK1	V
	$\overline{\text{PGNT}}/GP00$	V _{SS}	D _{VDD33}	V _{SS}	D _{VDD33}	VP0D04	VP0D08	VP0D16	VP0D18	VP0D17	VP0CTL2	U
	V _{SS}	D _{VDD33}	V _{SS}	C _{VDD}	V _{SS}	VP0D07	VP0D13/ GP13	VP0D14/ GP14	VP0D15/ GP15	V _{SS}	D _{VDD33}	T
	C _{VDD}	V _{SS}	C _{VDD}	V _{SS}	D _{VDD33}	VP0D19	VP1D02/ GP16	VP1D07/ GP21	VP1D06/ GP20	VP1D05/ GP19	VP1CTL0	R
	V _{SS}	C _{VDD}	V _{SS}	D _{VDD33}	V _{SS}	VP1D04/ GP18	VP1D03/ GP17	VP1D14/ GP26	VP1D13/ GP25	VP1CTL1	VP1CLK0	P
	C _{VDD}	V _{SS}	C _{VDD}	V _{SS}	D _{VDD33}	VP1D17/ GP29	VP1D12/ GP24	VP1D09/ GP23	VP1D08/ GP22	VP1CTL2	VP1CLK1	N
	V _{SS}	C _{VDD}	V _{SS}	D _{VDD33}	V _{SS}	VP1D16/ GP28	VP1D19/ GP31	VP1D15/ GP27	VP1D18/ GP30	V _{SS}	D _{VDD33}	M

Figure 2-3. ZUT Pin Map [Top Right Quadrant]



L	VP4CLK0/ AARDY	VP4D02/ ABE00	VP4D06/ ACE2	VP4D07/ ACE3	VP4D08/ AEA00	VP4D13/ AEA03	D _{VDD33}	V _{SS}	C _{VDD}	V _{SS}	C _{VDD}	V _{SS}
K	VP4CLK1	VP4CTL2/ ASADS/ASRE	VP4D09/ AEA01	VP4D12/ AEA02	VP4D14/ AEA04	VP4D19/ AEA09	V _{SS}	D _{VDD33}	V _{SS}	C _{VDD}	V _{SS}	C _{VDD}
J	VP4CTL1/ ABA1	VP4CTL0/ ABA0	VP4D15/ AEA05	VP4D16/ AEA06	VP4D17/ AEA07	VP4D18/ AEA08	D _{VDD33}	V _{SS}	C _{VDD}	V _{SS}	C _{VDD}	V _{SS}
H	V _{SS}	UHPIEN	HPIWIDTH/ AEA16	AEA23	AEA19	RSV_BOOT/ AEA15	RSV7	RSV8	C _{VDD1}	D _{VDD18}	V _{SS}	D _{VDD18}
G	D _{VDD33}	FASTBOOT /AEA21	EMIFA WIDTH/ AEA22	AECLKIN SEL/ AEA17	PCI66/ AEA18	BOOT MODE3/ AEA14	PLL2	V _{SS}	D _{VDD18}	V _{SS}	D _{VDD18}	V _{SS}
F	CLKIN2	DEVICE ENABLE0/ AEA20	BOOT MODE0/ AEA11	BOOT MODE1/ AEA12	BOOT MODE2/ AEA13	RSV18	V _{SS}	D _{VDD18}	$\overline{\text{DDR_CS}}$	DDR_A13	DDR_A06	DDR_A08
E	RSV12	RSV11	RSV14	RSV13	D _{VDD18}	V _{SS}	DDR_D07	DDR_D04	DDR_D00	$\overline{\text{DDR_RAS}}$	DDR_BA[2]	DDR_A12
D	RSV4	RSV3	RSV6	RSV5	DDR_ DQM[1]	DDR_D10	DDR_ DQGATE0	DDR_D05	V _{SS}	DDR_CAS	DDR_WE	V _{SS}
C	RSV20	RSV19	D _{VDD18}	V _{SS}	DDR_D15	DDR_D08	DDR_D06	DDR_D03	DDR_D01	D _{VDD18}	DDR_ VREF	DDR_BA[0]
B	D _{VDD18}	V _{DD18MON}	DDR_D12	DDR_D14	D _{VDD18}	DDR_ DQGATE1	DDR_D09	DDR_ DQM[0]	DDR_D02	A _{VDDL1}	DDR_CKE	DDR_BA[1]
A	V _{SS}	RSV10	DDR_D11	DDR_D13	V _{SS}	$\overline{\text{DDR_DQS}}[1]$	DDR_ DQS[1]	$\overline{\text{DDR_DQS}}[0]$	DDR_ DQS[0]	RSV15	DDR_CLK	$\overline{\text{DDR_CLK}}$
	1	2	3	4	5	6	7	8	9	10	11	12

Figure 2-4. ZUT Pin Map [Bottom Left Quadrant]

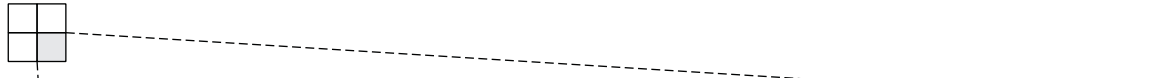

C _{VDD}	V _{SS}	C _{VDD}	V _{SS}	D _{VDD33}	EMU4	V _{CCMON}	RSV1	RSV2	TMS	$\overline{\text{TRST}}$	L
V _{SS}	C _{VDD}	V _{SS}	D _{VDD33}	V _{SS}	EMU11	EMU6	EMU3	EMU2	EMU1	EMU0	K
C _{VDD1}	V _{SS}	C _{VDD}	V _{SS}	D _{VDD33}	NMI	EMU10	EMU8	EMU5	TDI	TDO	J
V _{SS}	D _{VDD18}	V _{SS}	D _{VDD33}	V _{SS}	$\overline{\text{POR}}$	$\overline{\text{RESETSTAT}}$	EMU9	EMU7	D _{VDD33}	TCLK	H
D _{VDD18}	V _{SS}	D _{VDD18}	V _{SS}	D _{VDD18}	V _{SS}	D _{VDD33}	$\overline{\text{RESET}}$	V _{DD33MON}	V _{SS}	SPIDI/ UARTRTS	G
DDR_A02	D _{VDD18}	V _{SS}	D _{VDD18}	V _{SS}	D _{VDD18}	V _{SS}	D _{VDD33}	SPIDO/ UARTCTS	SPICLK	$\overline{\text{SPICS2/}}$ UARTRX	F
DDR_ODT0	DDR_A03	DDR_DQM[2]	DDR_D19	DDR_D23	DDR_DQGATE2	DDR_D31	T0INP12/ GP08	T1INP12/ GP10	D _{VDD33}	V _{SS}	E
DDR_A09	DDR_A04	DDR_A00	DDR_D18	DDR_D22	DDR_D25	DDR_D29	V _{SS}	T0OUT12/ GP09	SCL	$\overline{\text{SPICS1/}}$ UARTTX	D
D _{VDD18}	DDR_A05	DDR_A01	DDR_D17	DDR_D21	DDR_D24	DDR_D27	DDR_D30	D _{VDD18}	T1OUT12/ GP11	SDA	C
DDR_A11	DDR_A07	D _{VDD18}	DDR_D16	DDR_D20	D _{VDD18}	DDR_D26	DDR_D28	DDR_DQM[3]	A _{VLL2}	D _{VDD18}	B
DDR_A10	DDR_ODT1	V _{SS}	$\overline{\text{DDR}}_DQS[2]$	DDR_DQS[2]	V _{SS}	$\overline{\text{DDR}}_DQS[3]$	DDR_DQS[3]	DDR_DQGATE3	RSV16	V _{SS}	A
13	14	15	16	17	18	19	20	21	22	23	

Figure 2-5. ZUT Pin Map [Bottom Right Quadrant]

2.6 Terminal Functions

The terminal functions tables (Table 2-4 through Table 2-5) identify the external signal names, the associated pin (ball) numbers along with the mechanical package designator, the pin type, whether the pin has any internal pullup or pulldown resistors, and a functional pin description. For more detailed information on device configuration, peripheral selection, multiplexed/shared pin, and debugging considerations, see Section 3.

All device boot and configuration pins are multiplexed with functional pins. These pins function as device boot and configuration pins only during device reset. When both the reset pin ($\overline{\text{RESET}}$) and the power-on reset pin ($\overline{\text{POR}}$) are deasserted, the input states of these multiplexed device boot and configuration pins are sampled and latched into the BOOTCFG register. For proper device operation, these pins must be pulled up/down to the desired value via an external resistor.

Table 2-4. Terminal Functions

TERMINAL NAME	NO	TYPE ⁽¹⁾	INTERNAL PULLUP/PULLDOWN	OPER VOLT	DESCRIPTION
Clock/PLL Configuration					
CLKIN1	M1	I	IPD	3.3 V	Clock Input for PLL1
CLKIN2	F1	I	IPD	3.3 V	Clock Input for PLL2
REFCLKN ⁽²⁾	AC11	I			Differential Reference Clock input (negative) for SGMII
REFCLKP ⁽²⁾	AB11	I			Differential Reference Clock input (positive) for SGMII
PLLV1	N3	A		1.8 V	1.8-V I/O Supply Voltage for PLL1
PLLV2	G7	A		1.8 V	1.8-V I/O Supply Voltage for PLL2
SYSCLK5	M3	I/O/Z	IPD	3.3 V	Clock out of device speed/4
JTAG					
TCLK	H23	I	IPU	3.3 V	JTAG Test Port Clock
TDI	J22	I	IPU	3.3 V	JTAG Test Port Data In
TDO	J23	OZ	IPU	3.3 V	JTAG Test Port Data Out
TMS	L22	I	IPU	3.3 V	JTAG Test Port Mode Select
$\overline{\text{TRST}}$	L23	I	IPD	3.3 V	JTAG Test Port Reset
EMU0	K23	I/O/Z	IPU	3.3 V	JTAG Test Port Emulation 0
EMU1	K22	I/O/Z	IPU	3.3 V	JTAG Test Port Emulation 1
EMU2	K21	I/O/Z	IPU	3.3 V	JTAG Test Port Emulation 2
EMU3	K20	I/O/Z	IPU	3.3 V	JTAG Test Port Emulation 3
EMU4	L18	I/O/Z	IPU	3.3 V	JTAG Test Port Emulation 4
EMU5	J21	I/O/Z	IPU	3.3 V	JTAG Test Port Emulation 5
EMU6	K19	I/O/Z	IPU	3.3 V	JTAG Test Port Emulation 6
EMU7	H21	I/O/Z	IPU	3.3 V	JTAG Test Port Emulation 7
EMU8	J20	I/O/Z	IPU	3.3 V	JTAG Test Port Emulation 8
EMU9	H20	I/O/Z	IPU	3.3 V	JTAG Test Port Emulation 9
EMU10	J19	I/O/Z	IPU	3.3 V	JTAG Test Port Emulation 10
EMU11	K18	I/O/Z	IPU	3.3 V	JTAG Test Port Emulation 11
RESET/INTERRUPTS					
NMI	J18	I	IPD	3.3 V	Nonmaskable Interrupt
$\overline{\text{RESETSTAT}}$	H19	O		3.3 V	Reset Status Pin
$\overline{\text{RESET}}$	G20	I		3.3 V	Device Reset
$\overline{\text{POR}}$	H18	I		3.3 V	Power On Reset

(1) I = Input, O = Output, Z = High impedance, S = Supply voltage, GND = Ground, A = Analog signal

(2) The clock input buffers on the REFCLKP/N pins are compatible with LVDS and LVPECL clock sources. These input buffers include a 100-Ω termination (P to N) and a common-mode biasing. Because the common-mode biasing is included, the clock source must be AC coupled.

Table 2-4. Terminal Functions (continued)

TERMINAL NAME	NO	TYPE ⁽¹⁾	INTERNAL PULLUP/PULLDOWN	OPER VOLT	DESCRIPTION
HOST-PORT INTERFACE (HPI) or PERIPHERAL COMPONENT INTERCONNECT (PCI) or GPIO[0:7]					
AD00/HD00	AA22	I/O/Z		3.3 V	Host Port data [15:00] pin or PCI data-address bus [15:00] [default]
AD01/HD01	AB22	I/O/Z		3.3 V	
AD02/HD02	AC21	I/O/Z		3.3 V	
AD03/HD03	AA23	I/O/Z		3.3 V	
AD04/HD04	AC22	I/O/Z		3.3 V	
AD05/HD05	AB21	I/O/Z		3.3 V	
AD06/HD06	AA21	I/O/Z		3.3 V	
AD07/HD07	Y21	I/O/Z		3.3 V	
AD08/HD08	AB20	I/O/Z		3.3 V	
AD09/HD09	AA20	I/O/Z		3.3 V	
AD10/HD10	Y20	I/O/Z		3.3 V	
AD11/HD11	Y19	I/O/Z		3.3 V	
AD12/HD12	AB18	I/O/Z		3.3 V	
AD13/HD13	AA19	I/O/Z		3.3 V	
AD14/HD14	AC18	I/O/Z		3.3 V	
AD15/HD15	AA18	I/O/Z		3.3 V	
AD16/HD16	Y16	I/O/Z		3.3 V	Host Port data [31:16] pin or PCI data-address bus [31:16] [default]
AD17/HD17	AB15	I/O/Z		3.3 V	
AD18/HD18	AA15	I/O/Z		3.3 V	
AD19/HD19	Y15	I/O/Z		3.3 V	
AD20/HD20	W15	I/O/Z		3.3 V	
AD21/HD21	V15	I/O/Z		3.3 V	
AD22/HD22	AC14	I/O/Z		3.3 V	
AD23/HD23	AB14	I/O/Z		3.3 V	
AD24/HD24	W14	I/O/Z		3.3 V	
AD25/HD25	V14	I/O/Z		3.3 V	
AD26/HD26	AC13	I/O/Z		3.3 V	
AD27/HD27	AB13	I/O/Z		3.3 V	
AD28/HD28	AA13	I/O/Z		3.3 V	
AD29/HD29	Y13	I/O/Z		3.3 V	
AD30/HD30	W13	I/O/Z		3.3 V	
AD31/HD31	V13	I/O/Z		3.3 V	
PPAR/ $\overline{\text{HAS}}$	W19	I/O/Z		3.3 V	Host Address Strobe (I) or PCI parity [default]
$\overline{\text{PSTOP}}$ /HCNTL0	Y18	I/O/Z		3.3 V	Host Control selects between control, address, or data registers (I) or PCI Stop [default]
$\overline{\text{PDEVSEL}}$ /HCNTL1	Y17	I/O/Z		3.3 V	Host Control selects between control, address, or data registers (I) or PCI Device Select [default]
$\overline{\text{PPERR}}$ / $\overline{\text{HCS}}$	W17	I/O/Z		3.3 V	Host Chip Select (I) or PCI Parity Error [default]
$\overline{\text{PSERR}}$ / $\overline{\text{HDS1}}$	W18	I/O/Z		3.3 V	Host Data Strobe 1 (I) or PCI System Error [default]
$\overline{\text{PCBE0}}$ /GP04	AC20	I/O/Z		3.3 V	PCI Command/Byte Enable 0 or GP[4] [default]
$\overline{\text{PCBE1}}$ / $\overline{\text{HDS2}}$	AC17	I		3.3 V	PCI Command/Byte Enable 1 or host data strobe 2
$\overline{\text{PCBE2}}$ / $\overline{\text{HR}}/\overline{\text{W}}$	W16	I/O/Z		3.3 V	PCI Command/Byte Enable 2 or host read or write select (I)
$\overline{\text{PCBE3}}$ /GP07	Y14	I/O/Z		3.3 V	PCI Command/Byte Enable 3 or GPIO[7]
PCLK/HHWIL	AC15	I/O/Z		3.3 V	PCI Clock (I) [default] or host Half-word Select - first or second half-word (not necessarily high or low order) [For HPI16 bus width selection only] (I)

Table 2-4. Terminal Functions (continued)

TERMINAL NAME	NO	TYPE ⁽¹⁾	INTERNAL PULLUP/PULLDOWN	OPER VOLT	DESCRIPTION
$\overline{\text{PFRAME}}/\text{HINT}$	AA16	I/O/Z		3.3 V	PCI Frame or host interrupt from DSP to host (O/Z)
$\overline{\text{PIRDY}}/\text{HRDY}$	AB17	I/O/Z		3.3 V	PCI Initiator Ready [default] or Host Ready from DSP to host (O/Z)
$\overline{\text{PGNT}}/\text{GP00}$	U13	I/O/Z		3.3 V	PCI Bus Grant (I) or GPIO[0]
$\overline{\text{PRST}}/\text{GP01}$	U12	I/O/Z		3.3 V	PCI Reset (I) or GPIO[1]
$\overline{\text{PINTA}}/\text{GP02}$	V12	I/O/Z		3.3 V	PCI Interrupt A (O/Z) or GPIO[2]
$\overline{\text{PREQ}}/\text{GP03}$	AA12	I/O/Z		3.3 V	PCI Bus Request (O/Z) or GPIO[3]
$\overline{\text{PTRDY}}/\text{GP05}$	AA17	I/O/Z		3.3 V	PCI Target Ready or GPIO[5]
$\overline{\text{PIDSEL}}/\text{GP06}$	AA14	I/O/Z		3.3 V	PCI Initialization Device Select (I) or GPIO[6]
DDR2 MEMORY CONTROLLER					
DDR_BA[0]	C12	I/O/Z		1.8 V	DDR2 Memory Controller Bank Address Control
DDR_BA[1]	B12	I/O/Z		1.8 V	
DDR_BA[2]	E11	I/O/Z		1.8 V	
$\overline{\text{DDR_CS}}$	F9	I/O/Z		1.8 V	DDR2 Memory Controller Memory Space Enable
DDR_A00	D15	I/O/Z		1.8 V	DDR2 Memory Controller External Address
DDR_A01	C15	I/O/Z		1.8 V	
DDR_A02	F13	I/O/Z		1.8 V	
DDR_A03	E14	I/O/Z		1.8 V	
DDR_A04	D14	I/O/Z		1.8 V	
DDR_A05	C14	I/O/Z		1.8 V	
DDR_A06	F11	I/O/Z		1.8 V	
DDR_A07	B14	I/O/Z		1.8 V	
DDR_A08	F12	I/O/Z		1.8 V	
DDR_A09	D13	I/O/Z		1.8 V	
DDR_A10	A13	I/O/Z		1.8 V	
DDR_A11	B13	I/O/Z		1.8 V	
DDR_A12	E12	I/O/Z		1.8 V	
DDR_A13	F10	I/O/Z		1.8 V	
$\overline{\text{DDR_CLK}}$	A12	I/O/Z		1.8 V	Negative DDR2 Memory Controller Output Clock (CLKIN2 frequency x 10)
DDR_CLK	A11	I/O/Z		1.8 V	DDR2 Memory Controller Output Clock (CLKIN2 frequency x 10)
DDR_D00	E9	I/O/Z		1.8 V	DDR2 Memory Controller External Data
DDR_D01	C9	I/O/Z		1.8 V	
DDR_D02	B9	I/O/Z		1.8 V	
DDR_D03	C8	I/O/Z		1.8 V	
DDR_D04	E8	I/O/Z		1.8 V	
DDR_D05	D8	I/O/Z		1.8 V	
DDR_D06	C7	I/O/Z		1.8 V	
DDR_D07	E7	I/O/Z		1.8 V	
DDR_D08	C6	I/O/Z		1.8 V	
DDR_D09	B7	I/O/Z		1.8 V	
DDR_D10	D6	I/O/Z		1.8 V	
DDR_D11	A3	I/O/Z		1.8 V	
DDR_D12	B3	I/O/Z		1.8 V	
DDR_D13	A4	I/O/Z		1.8 V	
DDR_D14	B4	I/O/Z		1.8 V	
DDR_D15	C5	I/O/Z		1.8 V	

Table 2-4. Terminal Functions (continued)

TERMINAL NAME	NO	TYPE ⁽¹⁾	INTERNAL PULLUP/PULLDOWN	OPER VOLT	DESCRIPTION
DDR_D16	B16	I/O/Z		1.8 V	DDR2 Memory Controller External Data (continued)
DDR_D17	C16	I/O/Z		1.8 V	
DDR_D18	D16	I/O/Z		1.8 V	
DDR_D19	E16	I/O/Z		1.8 V	
DDR_D20	B17	I/O/Z		1.8 V	
DDR_D21	C17	I/O/Z		1.8 V	
DDR_D22	D17	I/O/Z		1.8 V	
DDR_D23	E17	I/O/Z		1.8 V	
DDR_D24	C18	I/O/Z		1.8 V	
DDR_D25	D18	I/O/Z		1.8 V	
DDR_D26	B19	I/O/Z		1.8 V	
DDR_D27	C19	I/O/Z		1.8 V	
DDR_D28	B20	I/O/Z		1.8 V	
DDR_D29	D19	I/O/Z		1.8 V	
DDR_D30	C20	I/O/Z		1.8 V	
DDR_D31	E19	I/O/Z		1.8 V	
DDR_ODT0	E13	I/O/Z		1.8 V	On-die termination signals to external DDR2 SDRAM. These pins are reserved for future use and should not be connected to the DDR2 SDRAM. Note: There are no on-die termination resistors implemented on the DM647/DM648 DSP die.
DDR_ODT1	A14	I/O/Z		1.8 V	
$\overline{\text{DDR_CAS}}$	D10	I/O/Z		1.8 V	DDR2 Memory Controller SDRAM column address strobe
DDR_CKE	B11	I/O/Z		1.8 V	DDR2 Memory Controller SDRAM clock-enable
DDR_DQGATE0	D7	I/O/Z		1.8 V	DDR2 Memory Controller Data Strobe Gate
DDR_DQGATE1	B6	I/O/Z		1.8 V	
DDR_DQGATE2	E18	I/O/Z		1.8 V	
DDR_DQGATE3	A21	I/O/Z		1.8 V	
DDR_DQM[0]	B8	I/O/Z		1.8 V	DDR2 Memory Controller Byte-enable Controls. Decoded from the low-order address bits. The number of address bits or byte enables used depends on the width of external memory. Byte-write enables for most types of memory. Can be directly connected to SDRAM read and write mask signal (SDQM).
DDR_DQM[1]	D5	I/O/Z		1.8 V	
DDR_DQM[2]	E15	I/O/Z		1.8 V	
DDR_DQM[3]	B21	I/O/Z		1.8 V	
DDR_DQS[0]	A9	I/O/Z		1.8 V	DDR2 Memory Controller Data Strobe [3:0]
DDR_DQS[1]	A7	I/O/Z		1.8 V	
DDR_DQS[2]	A17	I/O/Z		1.8 V	
DDR_DQS[3]	A20	I/O/Z		1.8 V	
$\overline{\text{DDR_DQS}}[0]$	A8	I/O/Z		1.8 V	DDR2 Memory Controller Data Strobe [3:0] Negative
$\overline{\text{DDR_DQS}}[1]$	A6	I/O/Z		1.8 V	
$\overline{\text{DDR_DQS}}[2]$	A16	I/O/Z		1.8 V	
$\overline{\text{DDR_DQS}}[3]$	A19	I/O/Z		1.8 V	
$\overline{\text{DDR_RAS}}$	E10	I/O/Z		1.8 V	DDR2 Memory Controller SDRAM Row Address Strobe
$\overline{\text{DDR_WE}}$	D11	I/O/Z		1.8 V	DDR2 Memory Controller SDRAM Write Enable

Table 2-4. Terminal Functions (continued)

TERMINAL NAME	NO	TYPE ⁽¹⁾	INTERNAL PULLUP/PULLDOWN	OPER VOLT	DESCRIPTION
CONFIGURATION AND EMIFA					
DEVICEENABLE0/AEA20	F2	I/O/Z	IPD	3.3 V	EMIFA External Address 20 (word address). (O/Z) For proper device operation, this pin must be externally pulled up with a 1-kΩ resistor at device reset
EMIFAWIDTH/AEA22	G3	I/O/Z	IPD	3.3 V	EMIFA External Address 22 (word address). (O/Z) EMIFA data bus width selection pin state captured at the rising edge of RESET. 0 - sets EMIFA CS2 to 8-bit data bus width 1 - sets EMIFA CS2 to 16 bit data bus width. For details, see Section 3 .
FASTBOOT/AEA21	G2	I/O/Z	IPD	3.3 V	EMIFA External Address 22 (word address). (O/Z) Enables FAST BOOT of the device. For details, see Section 3 .
UHPIEN	H2	I	IPD	3.3 V	UHPI Enable Pin. This pin controls the selection (enable/disable) of the HPI and GPIO[0:7] muxed with PCI. For details, see Section 3 .
HPIWIDTH/AEA16	H3	I/O/Z	IPD	3.3 V	EMIFA External Address 16 (word address) (O/Z) HPI peripheral bus width (HPI_WIDTH) select (Applies only when HPI is enabled; UHPIEN pin = 1)
RSV_BOOT/AEA15	H6	I/O/Z	IPU	3.3 V	EMIFA External Address 15 (word address) (O/Z) For proper device operation, this pin must be externally pulled up with a 1-kΩ resistor at device reset.
PCI66/AEA18	G5	I/O/Z	IPD	3.3 V	PCI Frequency Selection (PCI66). The PCI peripheral must be enabled (UHPIEN = 0) to use this function. PCI66_AEA18 selects the PCI operating frequency of 66 MHz or 33 MHz. PCI operating frequency is selected at reset via the pullup/pulldown resistor on the PCI66 pin AEA18: 0 - PCI operates at 33 MHz (default) 1 - PCI operates at 66 MHz.
BOOTMODE0/AEA11 BOOTMODE1/AEA12 BOOTMODE2/AEA13 BOOTMODE3/AEA14	F3 F4 F5 G6	I/O/Z	IPD	3.3 V	The BOOTMODE[3:0] defines what boot code is executed on device reset. See Section 3.2.1 for more details.
INTER-INTEGRATED CIRCUIT (I2C)					
SCL	D22	I/O/Z		3.3 V	I2C clock. When the I2C module is used, use an external pullup resistor.
SDA	C23	I/O/Z		3.3 V	I2C data. When I2C is used, make certain there is an external pullup resistor.
SGMII0/1 and MDIO⁽¹⁾⁽²⁾					
SGMII0RXN	AA10	I		1.2 V	Differential SGMII Port 0 RX input (negative)
SGMII0RXP	AA9	I		1.2 V	Differential SGMII Port 0 RX input (positive)
SGMII0TXN	W11	O		1.2 V	Differential SGMII Port 0 TX output (negative)
SGMII0TXP	Y11	O		1.2 V	Differential SGMII Port 0 TX output (positive)
SGMII1RXN	AC9	I		1.2 V	Differential SGMII Port 1 RX input (negative)
SGMII1RXP	AB9	I		1.2 V	Differential SGMII Port 1 RX input (positive)
SGMII1TXN	W9	O		1.2 V	Differential SGMII Port 1 TX output (negative)
SGMII1TXP	W8	O		1.2 V	Differential SGMII Port 1 TX output (positive)
MDCLK	U9	OZ	IPD	3.3 V	MDIO Serial Clock (MDCLK)

- (1) For DM647: Leave the SGMII1RXP/N and SGMII1TXP/N pins disconnected. Disable ENTX/ENRX bits in CFGTX1/CFGRX1 for SGMII1 and still configure the CFGPLL because the SerDes TXBCLK0 is used as the internal VBUS clock. For DM648: if one of the SGMII pair is not used, the same approach must be used.
- (2) If the Ethernet Subsystem is not used at all, these connections must be followed:
- Disconnect AA10, AA9, W11, Y11, AC9, AB9, W9, W8, and U9
 - Connect AC11 to CV_{DD}
 - Connect AB11 to V_{SS}
 - Directly connect V11 (V_{DDA}), W10 (V_{DDA}), T10 (V_{DDD}), U10 (V_{DDD}), AB8 (V_{DDT}), U11 (V_{DDT}), R9 (ESS core power), R11 (ESS core power) to CV_{DD}
 - Directly connect AB10, (V_{DDR}) to DV_{DD18}

Table 2-4. Terminal Functions (continued)

TERMINAL NAME	NO	TYPE ⁽¹⁾	INTERNAL PULLUP/PULLDOWN	OPER VOLT	DESCRIPTION
MDIO	U8	I/O/Z	IPU	3.3 V	MDIO Serial Data (MDIO)
SPI or UART					
SPICLK	F22	I/O/Z	IPU	3.3 V	SPI Clock Output
SPICS1/UARTTX	D23	I/O/Z	IPU	3.3 V	SPI Chip Select 1 or UART Transmit (O/Z)
SPICS2/UARTRX	F23	I/O/Z	IPU	3.3 V	SPI Chip Select 2 or UART Receive
SPIDI/UARTRTS	G23	I/O/Z	IPU	3.3 V	SPI Data input or UART Ready to send (O/Z)
SPIDO/UARTCTS	F21	I/O/Z	IPU	3.3 V	SPI Data Output or UART Clear to send
TIMER 0/1 or GPIO[8:11]					
T0INP12/GP08	E20	I/O/Z	IPD	3.3 V	Timer 0 input pin for lower 32-bit counter (I) or GPIO 8
T0OUT12/GP09	D21	I/O/Z	IPD	3.3 V	Timer 0 output pin for lower 32-bit counter (O/Z) or GPIO 9
T1INPL/GP10	E21	I/O/Z	IPD	3.3 V	Timer 1 input pin for lower 32-bit counter (I) or GPIO 10
T1OUT12/GP11	C22	I/O/Z	IPD	3.3 V	Timer 1 output pin for lower 32-bit counter(O/Z) or GPIO 11
McASP OR VIDEO PORT OR VIC					
AHCLKR	AC4	I/O/Z	IPD	3.3 V	McASP Receive high-frequency master clock
AHCLKX	AC3	I/O/Z	IPD	3.3 V	McASP Transmit high-frequency master clock
ACLKR	AC6	I/O/Z	IPD	3.3 V	McASP Receive master clock
ACLKX	AC7	I/O/Z	IPD	3.3 V	McASP Transmit master clock
AFSR	W6	I/O/Z	IPD	3.3 V	McASP Receive Frame sync or left/right clock (LRCLK)
AFSX	AA7	I/O/Z	IPD	3.3 V	McASP Transmit Frame sync or left/right clock (LRCLK)
AXR0	AB6	I/O/Z	IPD	3.3 V	McASP Data Pin [0:7]
AXR1	Y6		IPD	3.3 V	
AXR2	AA6		IPD	3.3 V	
AXR3	AB4		IPD	3.3 V	
AXR4	Y5		IPD	3.3 V	
AXR5	V7		IPD	3.3 V	
AXR6	AA4		IPD	3.3 V	
AXR7	V6		IPD	3.3 V	
STCLK/AXR8	Y7	I/O/Z	IPD	3.3 V	The STCLK signal drives the hardware counter for use by the video ports (I) or McASP data pin 8.
VDAC/AXR9	AA5	I/O/Z	IPD	3.3 V	VCXO Interpolated Control Port (VIC) single-bit digital-to-analog converter (VDAC) output (O) or McASP data pin 9
AMUTEIN	AB3	I/O/Z	IPD	3.3 V	McASP Mute Input
AMUTE	U7	I/O/Z	IPD	3.3 V	McASP Mute Output
VIDEO PORT 0 OR GPIO[12:15]					
VP0CLK0	Y23	I	IPU	3.3 V	Video Port 0 Clock 0 (I)
VP0CLK1	V23	I/O/Z	IPU	3.3 V	Video Port 0 Clock 1
VP0CTL0	Y22	I/O/Z	IPU	3.3 V	Video Port 0 Control 0
VP0CTL1	V22	I/O/Z	IPU	3.3 V	Video Port 0 Control 1
VP0CTL2	U23	I/O/Z	IPU	3.3 V	Video Port 0 Control 2
VP0D02	W20	I/O/Z	IPD	3.3 V	Video Port 0 Data 2
VP0D03	V18	I/O/Z	IPD	3.3 V	Video Port 0 Data 3
VP0D04	U18	I/O/Z	IPD	3.3 V	Video Port 0 Data 4
VP0D05	V19	I/O/Z	IPD	3.3 V	Video Port 0 Data 5
VP0D06	W21	I/O/Z	IPD	3.3 V	Video Port 0 Data 6
VP0D07	T18	I/O/Z	IPD	3.3 V	Video Port 0 Data 7
VP0D08	U19	I/O/Z	IPD	3.3 V	Video Port 0 Data 8

Table 2-4. Terminal Functions (continued)

TERMINAL NAME	NO	TYPE ⁽¹⁾	INTERNAL PULLUP/PULLDOWN	OPER VOLT	DESCRIPTION
VP0D09	V20	I/O/Z	IPD	3.3 V	Video Port 0 Data 9
VP0D12/GP12	V21	I/O/Z	IPD	3.3 V	Video Port 0 Data 12 or GPIO 12
VP0D13/GP13	T19	I/O/Z	IPD	3.3 V	Video Port 0 Data 13 or GPIO 13
VP0D14/GP14	T20	I/O/Z	IPD	3.3 V	Video Port 0 Data 14 or GPIO 14
VP0D15/GP15	T21	I/O/Z	IPD	3.3 V	Video Port 0 Data 15 or GPIO 15
VP0D16	U20	I/O/Z	IPD	3.3 V	Video Port 0 Data 16
VP0D17	U22	I/O/Z	IPD	3.3 V	Video Port 0 Data 17
VP0D18	U21	I/O/Z	IPD	3.3 V	Video Port 0 Data 18
VP0D19	R18	I/O/Z	IPD	3.3 V	Video Port 0 Data 19
VIDEO PORT 1 OR GPIO[16:31]					
VP1CLK0	P23	I	IPU	3.3 V	Video Port 1 Clock 0
VP1CLK1	N23	I/O/Z	IPU	3.3 V	Video Port 1 Clock 1
VP1CTL0	R23	I/O/Z	IPU	3.3 V	Video Port 1 Control 0
VP1CTL1	P22	I/O/Z	IPU	3.3 V	Video Port 1 Control 1
VP1CTL2	N22	I/O/Z	IPU	3.3 V	Video Port 1 Control 2
VP1D02/GP16	R19	I/O/Z	IPD	3.3 V	Video Port 1 Data 2 or GPIO 16
VP1D03/GP17	P19	I/O/Z	IPD	3.3 V	Video Port 1 Data 3 or GPIO 17
VP1D04/GP18	P18	I/O/Z	IPD	3.3 V	Video Port 1 Data 4 or GPIO 18
VP1D05/GP19	R22	I/O/Z	IPD	3.3 V	Video Port 1 Data 5 or GPIO 19
VP1D06/GP20	R21	I/O/Z	IPD	3.3 V	Video Port 1 Data 6 or GPIO 20
VP1D07/GP21	R20	I/O/Z	IPD	3.3 V	Video Port 1 Data 7 or GPIO 21
VP1D08/GP22	N21	I/O/Z	IPD	3.3 V	Video Port 1 Data 8 or GPIO 22
VP1D09/GP23	N20	I/O/Z	IPD	3.3 V	Video Port 1 Data 9 or GPIO 23
VP1D12/GP24	N19	I/O/Z	IPD	3.3 V	Video Port 1 Data 12 or GPIO 24
VP1D13/GP25	P21	I/O/Z	IPD	3.3 V	Video Port 1 Data 13 or GPIO 25
VP1D14/GP26	P20	I/O/Z	IPD	3.3 V	Video Port 1 Data 14 or GPIO 26
VP1D15/GP27	M20	I/O/Z	IPD	3.3 V	Video Port 1 Data 15 or GPIO 27
VP1D16/GP28	M18	I/O/Z	IPD	3.3 V	Video Port 1 Data 16 or GPIO 28
VP1D17/GP29	N18	I/O/Z	IPD	3.3 V	Video Port 1 Data 17 or GPIO 29
VP1D18/GP30	M21	I/O/Z	IPD	3.3 V	Video Port 1 Data 18 or GPIO 30
VP1D19/GP31	M19	I/O/Z	IPD	3.3 V	Video Port 1 Data 19 or GPIO 31
VIDEO PORT 2 OR VLYNQ					
VP2CLK0	AB1	I	IPU	3.3 V	Video Port 2 Clock 0 (I)
VP2CLK1/VCLK	W1	I/O/Z	IPU	3.3 V	Video Port 2 Clock 1 or VLYNQ Clock (I/O)
VP2CTL0	AA1	I/O/Z	IPU	3.3 V	Video Port 2 Control 0
VP2CTL1	AB2	I/O/Z	IPU	3.3 V	Video Port 2 Control 1
VP2CTL2/VSCRUN	Y1	I/O/Z	IPU	3.3 V	Video Port 2 Control 2 or VLYNQ serial clock run request (I/O)
VP2D02	W5	I/O/Z	IPD	3.3 V	Video Port 2 Data 2
VP2D03	AA2	I/O/Z	IPD	3.3 V	Video Port 2 Data 3
VP2D04	Y3	I/O/Z	IPD	3.3 V	Video Port 2 Data 4
VP2D05	U6	I/O/Z	IPD	3.3 V	Video Port 2 Data 5
VP2D06	Y2	I/O/Z	IPD	3.3 V	Video Port 2 Data 6
VP2D07	W3	I/O/Z	IPD	3.3 V	Video Port 2 Data 7
VP2D08	V5	I/O/Z	IPD	3.3 V	Video Port 2 Data 8
VP2D09	W4	I/O/Z	IPD	3.3 V	Video Port 2 Data 9
VP2D12/VRXD0	W2	I/O/Z	IPD	3.3 V	Video Port 2 Data 12 or VLYNQ receive data pin [0] (I)

Table 2-4. Terminal Functions (continued)

TERMINAL NAME	NO	TYPE ⁽¹⁾	INTERNAL PULLUP/PULLDOWN	OPER VOLT	DESCRIPTION
VP2D13/VRXD1	V3	I/O/Z	IPD	3.3 V	Video Port 2 Data 13 or VLYNQ receive data pin [1] (I)
VP2D14/VRXD2	V4	I/O/Z	IPD	3.3 V	Video Port 2 Data 14 or VLYNQ receive data pin [2] (I)
VP2D15/VRXD3	U1	I/O/Z	IPD	3.3 V	Video Port 2 Data 15 or VLYNQ receive data pin [3] (I)
VP2D16/VTXD0	U3	I/O/Z	IPD	3.3 V	Video Port 2 Data 16 or VLYNQ transmit data pin [0] (O)
VP2D17/VTXD1	U2	I/O/Z	IPD	3.3 V	Video Port 2 Data 17 or VLYNQ transmit data pin [1] (O)
VP2D18/VTXD2	U5	I/O/Z	IPD	3.3 V	Video Port 2 Data 18 or VLYNQ transmit data pin [2] (O)
VP2D19/VTXD3	U4	I/O/Z	IPD	3.3 V	Video Port 2 Data 19 or VLYNQ transmit data pin [3] (O)
VIDEO PORT 3 OR EMIFA					
VP3CLK0/ AECLKIN	T1	I	IPD	3.3 V	Video Port 3 Clock 0 (I) or EMIFA external input clock (I)
VP3CLK1/ AECLKOUT	P1	I/O/Z	IPD	3.3 V	Video Port 3 Clock 1 or EMIFA output clock (O/Z)
VP3CTL0/ AAW \bar{E} /ASWE	T2	I/O/Z	IPU	3.3 V	Video Port 3 Control 0 or Asynchronous memory write enable/Programmable synchronous interface write-enable
VP3CTL1/ AR \bar{W}	R1	I/O/Z	IPU	3.3 V	Video Port 3 Control 1 or Asynchronous memory read/write (O/Z)
VP3CTL2/ AAO \bar{E} /ASOE	P2	I/O/Z	IPU	3.3 V	Video Port 3 Control 2 or Asynchronous/Programmable synchronous memory output-enable (O/Z)
VP3D02/AED00	T6	I/O/Z	IPU	3.3 V	Video Port 3 Data 2 or EMIFA External Data 0
VP3D03/AED01	T5	I/O/Z	IPU	3.3 V	Video Port 3 Data 3 or EMIFA External Data 1
VP3D04/AED02	T4	I/O/Z	IPU	3.3 V	Video Port 3 Data 4 or EMIFA External Data 2
VP3D05/AED03	T3	I/O/Z	IPU	3.3 V	Video Port 3 Data 5 or EMIFA External Data 3
VP3D06/AED04	R6	I/O/Z	IPU	3.3 V	Video Port 3 Data 6 or EMIFA External Data 4
VP3D07/AED05	R5	I/O/Z	IPU	3.3 V	Video Port 3 Data 7 or EMIFA External Data 5
VP3D08/AED06	R4	I/O/Z	IPU	3.3 V	Video Port 3 Data 8 or EMIFA External Data 6
VP3D09/AED07	R3	I/O/Z	IPU	3.3 V	Video Port 3 Data 9 or EMIFA External Data 7
VP3D12/AED08	R2	I/O/Z	IPU	3.3 V	Video Port 3 Data 12 or EMIFA External Data 8
VP3D13/AED09	P6	I/O/Z	IPU	3.3 V	Video Port 3 Data 13 or EMIFA External Data 9
VP3D14/AED10	P5	I/O/Z	IPU	3.3 V	Video Port 3 Data 14 or EMIFA External Data 10
VP3D15/AED11	P4	I/O/Z	IPU	3.3 V	Video Port 3 Data 15 or EMIFA External Data 11
VP3D16/AED12	P3	I/O/Z	IPU	3.3 V	Video Port 3 Data 16 or EMIFA External Data 12
VP3D17/AED13	N4	I/O/Z	IPU	3.3 V	Video Port 3 Data 17 or EMIFA External Data 13
VP3D18/AED14	N6	I/O/Z	IPU	3.3 V	Video Port 3 Data 18 or EMIFA External Data 14
VP3D19/AED15	N5	I/O/Z	IPU	3.3 V	Video Port 3 Data 19 or EMIFA External Data 15
VIDEO PORT 4 OR EMIFA					
VP4CLK0/AARDY	L1	I	IPU	3.3 V	Video Port 4 Clock 0 (I) or Asynchronous memory ready input (I)
VP4CLK1	K1	I/O/Z	IPD	3.3 V	Video Port 4 Clock 1
VP4CTL0/ABA0	J2	I/O/Z	IPD	3.3 V	Video Port 4 Control 0 or EMIFA bank address control (ABA[1:0]) (O/Z). Active-low bank selects for the 16-bit EMIFA. When interfacing to 16-bit asynchronous devices, ABA1 carries bit 1 of the byte address. For an 8-bit asynchronous interface, ABA[1:0] are used to carry bits 1 and 0 of the byte address.
VP4CTL1/ABA1	J1	I/O/Z	IPD	3.3 V	Video Port 4 Control 1 or EMIFA bank address control (ABA[1:0]) (O/Z). Active-low bank selects for the 16-bit EMIFA. WHEN interfacing to 16-bit asynchronous devices, ABA1 carries bit 1 of the byte address. For an 8-bit asynchronous interface, ABA[1:0] are used to carry bits 1 and 0 of the byte address.

Table 2-4. Terminal Functions (continued)

TERMINAL NAME	NO	TYPE ⁽¹⁾	INTERNAL PULLUP/PULLDOWN	OPER VOLT	DESCRIPTION
VP4CTL2/ $\overline{\text{ASADS}}$ / $\overline{\text{ASRE}}$	K2	I/O/Z	IPD	3.3 V	Video Port 4 Control 2 or Programmable synchronous address strobe or read-enable. For programmable synchronous interface, the r_enable field in the ChipSelect x Configuration Register selects between $\overline{\text{ASADS}}$ and $\overline{\text{ASRE}}$: – If $r_enable = 0$, then the $\overline{\text{ASADS}}$ / $\overline{\text{ASRE}}$ signal functions as the $\overline{\text{ASADS}}$ signal. – If $r_enable = 1$, then the $\overline{\text{ASADS}}$ / $\overline{\text{ASRE}}$ signal functions as the $\overline{\text{ASRE}}$ signal.
VP4D02/ $\overline{\text{ABE00}}$	L2	I/O/Z	IPU	3.3 V	Video Port 4 Data 2 or EMIFA byte-enable control 0. Decoded from the low-order address bits. The number of address bits or byte enables used depends on the width of external memory. Byte-write enables for most types of memory.
VP4D03/ $\overline{\text{ABE01}}$	M4	I/O/Z	IPU	3.3 V	Video Port 4 Data 3 or EMIFA byte-enable control 1. Number of address bits or byte enables used depends on the width of external memory. Byte-write enables for most types of memory.
VP4D04/ $\overline{\text{AEA10}}$	M5	I/O/Z	IPU	3.3 V	Video Port 4 Data 4 or EMIFA External Address 10 (word address) (O/Z)
VP4D05	M6	I/O/Z	IPU	3.3 V	Video Port 4 Data 5
VP4D06/ $\overline{\text{ACE2}}$	L3	I/O/Z	IPU	3.3 V	Video Port 4 Data 6 or EMIFA memory space enable 2
VP4D07/ $\overline{\text{ACE3}}$	L4	I/O/Z	IPU	3.3 V	Video Port 4 Data 7 or EMIFA memory space enable 3
VP4D08/ $\overline{\text{AEA00}}$	L5	I/O/Z	IPD	3.3 V	Video Port 4 Data 8 or EMIFA External Address 0 (word address) (O/Z)
VP4D09/ $\overline{\text{AEA01}}$	K3	I/O/Z	IPD	3.3 V	Video Port 4 Data 9 or EMIFA External Address 1 (word address) (O/Z)
VP4D12/ $\overline{\text{AEA02}}$	K4	I/O/Z	IPD	3.3 V	Video Port 4 Data 12 or EMIFA External Address 2 (word address) (O/Z)
VP4D13/ $\overline{\text{AEA03}}$	L6	I/O/Z	IPD	3.3 V	Video Port 4 Data 13 or EMIFA External Address 3 (word address) (O/Z)
VP4D14/ $\overline{\text{AEA04}}$	K5	I/O/Z	IPD	3.3 V	Video Port 4 Data 14 or EMIFA External Address 4 (word address) (O/Z)
VP4D15/ $\overline{\text{AEA05}}$	J3	I/O/Z	IPD	3.3 V	Video Port 4 Data 15 or EMIFA External Address 5 (word address) (O/Z)
VP4D16/ $\overline{\text{AEA06}}$	J4	I/O/Z	IPD	3.3 V	Video Port 4 Data 16 or EMIFA External Address 6 (word address) (O/Z)
VP4D17/ $\overline{\text{AEA07}}$	J5	I/O/Z	IPD	3.3 V	Video Port 4 Data 17 or EMIFA External Address 7 (word address) (O/Z)
VP4D18/ $\overline{\text{AEA08}}$	J6	I/O/Z	IPD	3.3 V	Video Port 4 Data 18 or EMIFA External Address 8 (word address) (O/Z)
VP4D19/ $\overline{\text{AEA09}}$	K6	I/O/Z	IPD	3.3 V	Video Port 4 Data 19 or EMIFA External Address 9 (word address) (O/Z)
EMIFA					
AEA23	H4	OZ	IPD	3.3 V	EMIFA External Address 23 (word address) (O/Z)
AEA19	H5	O/Z	IPU	3.3 V	EMIFA External Address 19 (word address) (O/Z)
AECLKINSEL/ $\overline{\text{AEA17}}$	G4	I/O/Z	IPD	3.3 V	Select EMIFA external clock (I) (The EMIFA input clock AECLKIN or SYSCLK4 is selected at reset via the pullup/pulldown resistor on this pin. Note: AECLKIN is the default for the EMIFA input clock.) or EMIFA external address 17 (word address) (O/Z)

Table 2-5. Terminal Functions (Ground and Power Supply)

TERMINAL NAME	NO	TYPE ⁽¹⁾	INTERNAL PULLUP/ PULLDOWN	OPER VOLT	DESCRIPTION
V _{SS}	A1				Ground
V _{SS}	A5				Ground
V _{SS}	A15				Ground
V _{SS}	A18				Ground
V _{SS}	A23				Ground
V _{SS}	C4				Ground
V _{SS}	D9				Ground
V _{SS}	D12				Ground
V _{SS}	D20				Ground
V _{SS}	E6				Ground
V _{SS}	E23				Ground
V _{SS}	F7				Ground
V _{SS}	F15				Ground
V _{SS}	F17				Ground
V _{SS}	F19				Ground
V _{SS}	G8				Ground
V _{SS}	G10				Ground
V _{SS}	G12				Ground
V _{SS}	G14				Ground
V _{SS}	G16				Ground
V _{SS}	G18				Ground
V _{SS}	G22				Ground
V _{SS}	H1				Ground
V _{SS}	H11				Ground
V _{SS}	H13				Ground
V _{SS}	H15				Ground
V _{SS}	H17				Ground
V _{SS}	J8				Ground
V _{SS}	J10				Ground
V _{SS}	J12				Ground
V _{SS}	J14				Ground
V _{SS}	J16				Ground
V _{SS}	K7				Ground
V _{SS}	K9				Ground
V _{SS}	K11				Ground
V _{SS}	K13				Ground
V _{SS}	K15				Ground
V _{SS}	K17				Ground
V _{SS}	L8				Ground
V _{SS}	L10				Ground
V _{SS}	L12				Ground
V _{SS}	L14				Ground
V _{SS}	L16				Ground
V _{SS}	M7				Ground
V _{SS}	M9				Ground

(1) I = Input, O = Output, Z = High impedance, S = Supply voltage, GND = Ground, A = Analog signal

Table 2-5. Terminal Functions (Ground and Power Supply) (continued)

TERMINAL NAME	NO	TYPE ⁽¹⁾	INTERNAL PULLUP/PULLDOWN	OPER VOLT	DESCRIPTION
V _{SS}	M11				Ground
V _{SS}	M13				Ground
V _{SS}	M15				Ground
V _{SS}	M17				Ground
V _{SS}	M22				Ground
V _{SS}	N1				Ground
V _{SS}	N8				Ground
V _{SS}	N10				Ground
V _{SS}	N12				Ground
V _{SS}	N14				Ground
V _{SS}	N16				Ground
V _{SS}	P7				Ground
V _{SS}	P9				Ground
V _{SS}	P11				Ground
V _{SS}	P13				Ground
V _{SS}	P15				Ground
V _{SS}	P17				Ground
V _{SS}	R10				Ground
V _{SS}	R12				Ground
V _{SS}	R14				Ground
V _{SS}	R16				Ground
V _{SS}	T7				Ground
V _{SS}	T9				Ground
V _{SS}	T11				Ground
V _{SS}	T13				Ground
V _{SS}	T15				Ground
V _{SS}	T17				Ground
V _{SS}	T22				Ground
V _{SS}	U14				Ground
V _{SS}	U16				Ground
V _{SS}	V1				Ground
V _{SS}	V9				Ground
V _{SS}	V17				Ground
V _{SS}	W7				Ground
V _{SS}	W22				Ground
V _{SS}	Y9				Ground
V _{SS}	Y10				Ground
V _{SS}	AA3				Ground
V _{SS}	AA8				Ground
V _{SS}	AA11				Ground
V _{SS}	AB5				Ground
V _{SS}	AB19				Ground
V _{SS}	AB23				Ground
V _{SS}	AC1				Ground
V _{SS}	AC8				Ground
V _{SS}	AC10				Ground

Table 2-5. Terminal Functions (Ground and Power Supply) (continued)

TERMINAL NAME	NO	TYPE ⁽¹⁾	INTERNAL PULLUP/ PULLDOWN	OPER VOLT	DESCRIPTION
V _{SS}	AC12				Ground
V _{SS}	AC16				Ground
POWER PINS					
CV _{DD}	J9				1.2-V Core Power Supply
CV _{DD}	J11				1.2-V Core Power Supply
CV _{DD}	J15				1.2-V Core Power Supply
CV _{DD}	K10				1.2-V Core Power Supply
CV _{DD}	K12				1.2-V Core Power Supply
CV _{DD}	K14				1.2-V Core Power Supply
CV _{DD}	L9				1.2-V Core Power Supply
CV _{DD}	L11				1.2-V Core Power Supply
CV _{DD}	L13				1.2-V Core Power Supply
CV _{DD}	L15				1.2-V Core Power Supply
CV _{DD}	M10				1.2-V Core Power Supply
CV _{DD}	M12				1.2-V Core Power Supply
CV _{DD}	M14				1.2-V Core Power Supply
CV _{DD}	N11				1.2-V Core Power Supply
CV _{DD}	N13				1.2-V Core Power Supply
CV _{DD}	N15				1.2-V Core Power Supply
CV _{DD}	P10				1.2-V Core Power Supply
CV _{DD}	P12				1.2-V Core Power Supply
CV _{DD}	P14				1.2-V Core Power Supply
CV _{DD}	R13				1.2-V Core Power Supply
CV _{DD}	N9				1.2-V Core Power Supply
CV _{DD}	T16				1.2-V Core Power Supply
CV _{DD}	R8				1.2-V Core Power Supply
CV _{DD}	R15				1.2-V Core Power Supply
CV _{DD}	V8				1.2-V Core Power Supply
CV _{DDESS}	R11				1.2-V Core Power Supply for Ethernet Subsystem
CV _{DDESS}	R9				1.2-V Core Power Supply for Ethernet Subsystem
AV _{DLL1}	B10				1.8-V I/O supply
AV _{DLL2}	B22				1.8-V I/O supply
CV _{DD1}	H9				1.2-V Power supply for DDR, DDR I/Os, EMIF-DDR Subsystem
CV _{DD1}	J13				1.2-V Power supply for DDR, DDR I/Os, EMIF-DDR Subsystem
AV _{DDA}	V11				1.2-V SerDes Analog supply
AV _{DDA}	W10				1.2-V SerDes Analog supply
DV _{DDD}	T10				1.2-V SerDes Digital Supply
DV _{DDD}	U10				1.2-V SerDes Digital Supply
AV _{DDR}	AB10				1.8-V SerDes Analog Supply (Regulator)
AV _{DDT}	AB8				1.2-V SerDes Analog Supply
AV _{DDT}	U11				1.2-V SerDes Analog Supply
DV _{DD33}	E22				3.3-V I/O supply voltage
DV _{DD33}	F20				3.3-V I/O supply voltage
DV _{DD33}	G1				3.3-V I/O supply voltage

Table 2-5. Terminal Functions (Ground and Power Supply) (continued)

TERMINAL NAME	NO	TYPE ⁽¹⁾	INTERNAL PULLUP/ PULLDOWN	OPER VOLT	DESCRIPTION
DV _{DD33}	G19				3.3-V I/O supply voltage
DV _{DD33}	J7				3.3-V I/O supply voltage
DV _{DD33}	H16				3.3-V I/O supply voltage
DV _{DD33}	H22				3.3-V I/O supply voltage
DV _{DD33}	J17				3.3-V I/O supply voltage
DV _{DD33}	K8				3.3-V I/O supply voltage
DV _{DD33}	K16				3.3-V I/O supply voltage
DV _{DD33}	L7				3.3-V I/O supply voltage
DV _{DD33}	L17				3.3-V I/O supply voltage
DV _{DD33}	M8				3.3-V I/O supply voltage
DV _{DD33}	M16				3.3-V I/O supply voltage
DV _{DD33}	M23				3.3-V I/O supply voltage
DV _{DD33}	N2				3.3-V I/O supply voltage
DV _{DD33}	N7				3.3-V I/O supply voltage
DV _{DD33}	N17				3.3-V I/O supply voltage
DV _{DD33}	P8				3.3-V I/O supply voltage
DV _{DD33}	P16				3.3-V I/O supply voltage
DV _{DD33}	R7				3.3-V I/O supply voltage
DV _{DD33}	R17				3.3-V I/O supply voltage
DV _{DD33}	T8				3.3-V I/O supply voltage
DV _{DD33}	T12				3.3-V I/O supply voltage
DV _{DD33}	T14				3.3-V I/O supply voltage
DV _{DD33}	T23				3.3-V I/O supply voltage
DV _{DD33}	AB7				3.3-V I/O supply voltage
DV _{DD33}	U15				3.3-V I/O supply voltage
DV _{DD33}	U17				3.3-V I/O supply voltage
DV _{DD33}	V2				3.3-V I/O supply voltage
DV _{DD33}	V16				3.3-V I/O supply voltage
DV _{DD33}	W23				3.3-V I/O supply voltage
DV _{DD33}	Y4				3.3-V I/O supply voltage
DV _{DD33}	Y8				3.3-V I/O supply voltage
DV _{DD33}	AB16				3.3-V I/O supply voltage
DV _{DD33}	AC2				3.3-V I/O supply voltage
DV _{DD33}	AC5				3.3-V I/O supply voltage
DV _{DD33}	AB12				3.3-V I/O supply voltage
DV _{DD33}	AC19				3.3-V I/O supply voltage
DV _{DD33}	AC23				3.3-V I/O supply voltage
DV _{DD18}	B1				1.8-V I/O supply voltage (DDR2 Memory Controller)
DV _{DD18}	B5				1.8-V I/O supply voltage (DDR2 Memory Controller)
DV _{DD18}	B15				1.8-V I/O supply voltage (DDR2 Memory Controller)
DV _{DD18}	B18				1.8-V I/O supply voltage (DDR2 Memory Controller)
DV _{DD18}	B23				1.8-V I/O supply voltage (DDR2 Memory Controller)
DV _{DD18}	C3				1.8-V I/O supply voltage (DDR2 Memory Controller)
DV _{DD18}	C10				1.8-V I/O supply voltage (DDR2 Memory Controller)
DV _{DD18}	C13				1.8-V I/O supply voltage (DDR2 Memory Controller)
DV _{DD18}	C21				1.8-V I/O supply voltage (DDR2 Memory Controller)

Table 2-5. Terminal Functions (Ground and Power Supply) (continued)

TERMINAL NAME	NO	TYPE ⁽¹⁾	INTERNAL PULLUP/ PULLDOWN	OPER VOLT	DESCRIPTION
DV _{DD18}	E5				1.8-V I/O supply voltage (DDR2 Memory Controller)
DV _{DD18}	F8				1.8-V I/O supply voltage (DDR2 Memory Controller)
DV _{DD18}	F14				1.8-V I/O supply voltage (DDR2 Memory Controller)
DV _{DD18}	F16				1.8-V I/O supply voltage (DDR2 Memory Controller)
DV _{DD18}	F18				1.8-V I/O supply voltage (DDR2 Memory Controller)
DV _{DD18}	G9				1.8-V I/O supply voltage (DDR2 Memory Controller)
DV _{DD18}	G11				1.8-V I/O supply voltage (DDR2 Memory Controller)
DV _{DD18}	G13				1.8-V I/O supply voltage (DDR2 Memory Controller)
DV _{DD18}	G15				1.8-V I/O supply voltage (DDR2 Memory Controller)
DV _{DD18}	G17				1.8-V I/O supply voltage (DDR2 Memory Controller)
DV _{DD18}	H10				1.8-V I/O supply voltage (DDR2 Memory Controller)
DV _{DD18}	H12				1.8-V I/O supply voltage (DDR2 Memory Controller)
DV _{DD18}	H14				1.8-V I/O supply voltage (DDR2 Memory Controller)
DDR_VREF	C11				(DV _{DD18} /2)-V reference for SSTL buffer (DDR2 Memory Controller). This input voltage can be generated directly from DV _{DD18} using two 1-K Ω resistors to form a resistor divider circuit.
V _{CCMON}	L19				Die-side 1.2-V core supply voltage monitor pin. The monitor pins indicate the voltage on the die, and, therefore, provide the best probe point for voltage monitoring purposes. If the V _{CCMON} pin is not used, it should be connected directly to the 1.2-V core supply or left unconnected.
V _{DD18MON}	B2				Die-side 1.8-V I/O supply voltage monitor pin. The monitor pins indicate the voltage on the die and, therefore, provide the best probe point for voltage monitoring purposes. If the V _{DD18MON} pin is not used, it should be connected directly to the 1.8-V I/O supply (DV _{DD18}).
V _{DD33MON}	G21				Die-side 3.3-V I/O supply voltage monitor pin. The monitor pins indicate the voltage on the die and, therefore, provide the best probe point for voltage monitoring purposes. If the V _{DD33MON} pin is not used, it should be connected directly to the 3.3-V I/O supply (DV _{DD33}).
Reserved					
RSV 1	L20	A			Reserved. Unconnected
RSV 2	L21	A			Reserved. Unconnected
RSV 3	D2	O			Reserved. Unconnected
RSV 4	D1	O			Reserved. Unconnected
RSV 5	D4	O			Reserved. Unconnected
RSV 6	D3	O			Reserved. Unconnected
RSV 7	H7	A			Reserved. These pins must be connected directly to V _{SS} for proper device operation.
RSV 8	H8	A			Reserved. These pins must be connected directly to V _{SS} for proper device operation.
RSV 9	M2	A			Reserved. Unconnected
RSV 10	A2	A			Reserved. Unconnected
RSV 11	E2				Reserved. This pin must be connected directly to V _{SS} for proper device operation.
RSV 12	E1				Reserved. This pin must be connected directly to 1.8-V I/O supply
RSV 13	E4				Reserved. This pin must be connected directly to V _{SS} for proper device operation.
RSV 14	E3				Reserved. This pin must be connected directly to 1.8-V I/O supply

Table 2-5. Terminal Functions (Ground and Power Supply) (continued)

TERMINAL NAME	NO	TYPE ⁽¹⁾	INTERNAL PULLUP/PULLDOWN	OPER VOLT	DESCRIPTION
RSV 15	A10	A			Reserved. Unconnected
RSV 16	A22	A			Reserved. Unconnected
RSV 17	V10	A			Reserved. Unconnected
RSV 18	F6	I			Reserved. These pins must be connected directly to 1.8-V I/O supply(DV _{DD18}) for proper device operation.
RSV 19	C2				Reserved. This pin must be connected to the 1.8-V I/O supply (DV _{DD18}) via a 200-Ω resistor for proper device operation. NOTE: If the DDR2 Memory Controller is not used, the DDR_VREF, RSV19, and RSV20 pins can be directly connected to ground (V _{SS}) to save power. However, connecting these pins directly to ground will prevent boundary scan from functioning on the DDR2 Memory Controller pins. To preserve boundary-scan functionality on the DDR2 Memory Controller pins, see Section 6.3.6 .
RSV 20	C1				Reserved. This pin must be connected to ground (V _{SS}) via a 200-Ω resistor for proper device operation. NOTE: If the DDR2 Memory Controller is not used, the RSV 19 and RSV 20 pins can be directly connected to ground (V _{SS}) to save power. However, connecting these pins directly to ground will prevent boundary scan from functioning on the DDR2 Memory Controller pins. To preserve boundary-scan functionality on the DDR2 Memory Controller pins, see Section 6.3.6 .
RSV 21	Y12				Reserved. This pin must be connected via a 20-Ω resistor directly to 3.3-V I/O Supply (DV _{DD33}) for proper device operation. The resistor used should have a minimal rating of 250 mW.
RSV 22	W12				Reserved. This pin must be connected via a 40-Ω resistor directly to ground (V _{SS}) for proper device operation. The resistor used should have a minimal rating of 100 mW.

2.7 Device Support

2.7.1 Development Support

TI offers an extensive line of development tools for the TMS320DM64x DMP platform, including tools to evaluate the performance of the processors, generate code, develop algorithm implementations, and fully integrate and debug software and hardware modules. The tools support documentation is electronically available within the Code Composer Studio™ Integrated Development Environment (IDE).

The following products support development of TMS320DM64xx DMP-based applications:

Software Development Tools:

Code Composer Studio™ Integrated Development Environment (IDE): including Editor C/C++/Assembly Code Generation, and Debug plus additional development tools
Scalable, Real-Time Foundation Software (DSP/BIOS™), which provides the basic run-time target software needed to support any SoC application.

Hardware Development Tools:

Extended Development System (XDS™) Emulator (supports TMS320DM64x multiprocessor system debug) EVM (Evaluation Module)

For a complete listing of development-support tools for the TMS320DM64x platform, visit the Texas Instruments website at www.ti.com. For information on pricing and availability, contact the nearest TI field sales office or authorized distributor.

2.7.2 Device and Development-Support Tool Nomenclature

To designate the stages in the product development cycle, TI assigns prefixes to the part numbers of all DSP devices and support tools. Each DSP commercial family member has one of three prefixes: TMX, TMP, or TMS (e.g., TMS320DM648ZUTA7). Texas Instruments recommends two of three possible prefix designators for its support tools: TMDX and TMDS. These prefixes represent evolutionary stages of product development from engineering prototypes (TMX/TMDX) through fully qualified production devices/tools (TMS/TMDS).

Device development evolutionary flow:

- TMX** Experimental device that is not necessarily representative of the final device's electrical specifications.
- TMP** Final silicon die that conforms to the device's electrical specifications but has not completed quality and reliability verification.
- TMS** Fully-qualified production device.

Support tool development evolutionary flow:

- TMDX** Development-support product that has not yet completed Texas Instruments internal qualification testing.
- TMDS** Fully qualified development-support product.

TMX and TMP devices and TMDX development-support tools are shipped against the following disclaimer:

"Developmental product is intended for internal evaluation purposes."

TMS devices and TMDS development-support tools have been characterized fully, and the quality and reliability of the device have been demonstrated fully. TI's standard warranty applies.

Predictions show that prototype devices (TMX or TMP) have a greater failure rate than the standard production devices. Texas Instruments recommends that these devices not be used in any production system because their expected end-use failure rate still is undefined. Only qualified production devices are to be used.

TI device nomenclature also includes a suffix with the device family name. This suffix indicates the package type (for example, ZUT), the temperature range (for example, "Blank" is the commercial temperature range), and the device speed range in megahertz (for example, "Blank" is the default [720-MHz]).

Figure 2-6 provides a legend for reading the complete device name for the devices.

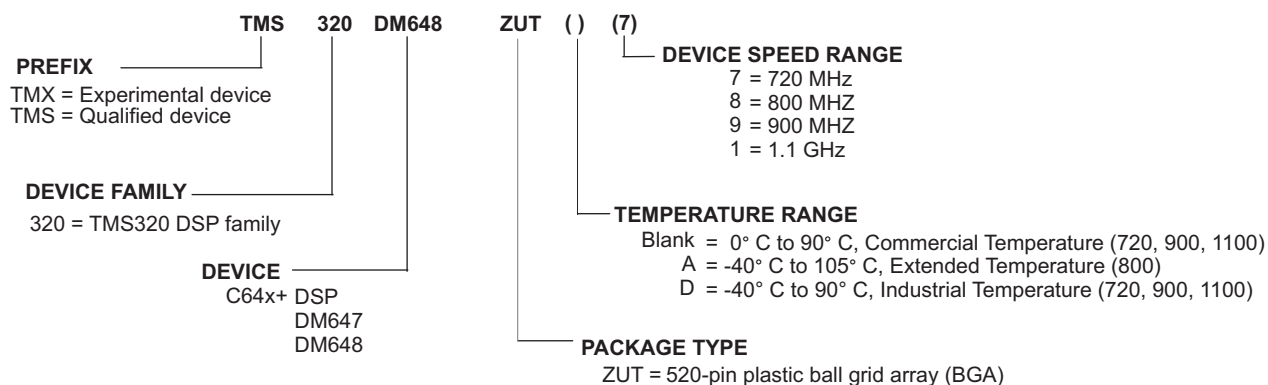

Figure 2-6. Device Nomenclature

2.7.3 Related Documentation From Texas Instruments

The following documents describe the devices. Copies of these documents are available on the Internet at www.ti.com. *Tip:* Enter the literature number in the search box provided at www.ti.com.

The current documentation that describes the DM64x DMP, related peripherals, and other technical collateral, is available in the C6000 DSP product folder at: www.ti.com/c6000.

[SPRU732](#) ***TMS320C64x/C64x+ DSP CPU and Instruction Set Reference Guide*** describes the CPU architecture, pipeline, instruction set, and interrupts for the TMS320C64x and TMS320C64x+ digital signal processors (DSPs) of the TMS320C6000 DSP family. The C64x/C64x+ DSP generation comprises fixed-point devices in the C6000 DSP platform. The C64x+ DSP is an enhancement of the C64x DSP with added functionality and an expanded instruction set.

[SPRUEK5](#) ***TMS320DM647/DM648 DSP DDR2 Memory Controller User's Guide*** describes the DDR2 memory controller in the TMS320DM647/DM648 Digital Signal Processor (DSP). The DDR2/mDDR memory controller is used to interface with JESD79D-2A standard compliant DDR2 SDRAM devices and standard Mobile DDR SDRAM devices.

[SPRUEK6](#) ***TMS320DM647/DM648 DSP External Memory Interface (EMIF) User's Guide*** describes the operation of the asynchronous external memory interface (EMIF) in the TMS320DM647/DM648 Digital Signal Processor (DSP). The EMIF supports a glueless interface to a variety of external devices.

[SPRUEK7](#) ***TMS320DM647/DM648 DSP General-Purpose Input/Output (GPIO) User's Guide*** describes the general-purpose input/output (GPIO) peripheral in the TMS320DM647/DM648 Digital Signal Processor (DSP). The GPIO peripheral provides dedicated general-purpose pins that can be configured as either inputs or outputs. When configured as an input, you can detect the state of the input by reading the state of an internal register. When configured as an output, you can write to an internal register to control the state driven on the output pin.

[SPRUEK8](#) ***TMS320DM647/DM648 DSP Inter-Integrated Circuit (I2C) Module User's Guide*** describes the inter-integrated circuit (I2C) peripheral in the TMS320DM647/DM648 Digital Signal Processor (DSP). The I2C peripheral provides an interface between the DSP and other devices compliant with the I2C-bus specification and connected by way of an I2C-bus. External components attached to this 2-wire serial bus can transmit and receive up to 8-bit wide data to and from the DSP through the I2C peripheral. This document assumes the reader is familiar with the I2C-bus specification.

[SPRUELO](#) ***TMS320DM647/DM648 DSP 64-Bit Timer User's Guide*** describes the operation of the 64-bit timer in the TMS320DM647/DM648 Digital Signal Processor (DSP). The timer can be configured as a general-purpose 64-bit timer or dual general-purpose 32-bit timers.

[SPRUEL1](#) ***TMS320DM647/DM648 DSP Multichannel Audio Serial Port (McASP) User's Guide*** describes the multichannel audio serial port (McASP) in the TMS320DM647/DM648 Digital Signal Processor (DSP). The McASP functions as a general-purpose audio serial port optimized for the needs of multichannel audio applications. The McASP is useful for time-division multiplexed (TDM) stream, Inter-Integrated Sound (I2S) protocols, and intercomponent digital audio interface transmission (DIT).

[SPRUEL2](#) ***TMS320DM647/DM648 DSP Enhanced DMA (EDMA) Controller User's Guide*** describes the operation of the enhanced direct memory access (EDMA3) controller in the TMS320DM647/DM648 Digital Signal Processor (DSP). The EDMA3 controller's primary purpose is to service user-programmed data transfers between two memory-mapped slave endpoints on the DSP.

[SPRUEL4](#) ***TMS320DM647/DM648 DSP Peripheral Component Interconnect (PCI) User's Guide*** describes the peripheral component interconnect (PCI) port in the TMS320DM647/DM648 Digital Signal Processor (DSP). The PCI port supports connection of the C642x DSP to a

PCI host via the integrated PCI master/slave bus interface. The PCI port interfaces to the DSP via the enhanced DMA (EDMA) controller. This architecture allows for both PCI master and slave transactions, while keeping the EDMA channel resources available for other applications.

- [SPRUJEL5](#)** ***TMS320DM647/DM648 DSP Host Port Interface (UHPI) User's Guide*** describes the host port interface (HPI) in the TMS320DM647/DM648 Digital Signal Processor (DSP). The HPI is a parallel port through which a host processor can directly access the CPU memory space. The host device functions as a master to the interface, which increases ease of access. The host and CPU can exchange information via internal or external memory. The host also has direct access to memory-mapped peripherals. Connectivity to the CPU memory space is provided through the enhanced direct memory access (EDMA) controller.
- [SPRUJEL8](#)** ***TMS320DM647/DM648 DSP Universal Asynchronous Receiver/Transmitter (UART) User's Guide*** describes the universal asynchronous receiver/transmitter (UART) peripheral in the TMS320DM647/DM648 Digital Signal Processor (DSP). The UART peripheral performs serial-to-parallel conversion on data received from a peripheral device, and parallel-to-serial conversion on data received from the CPU.
- [SPRUJEL9](#)** ***TMS320DM647/DM648 DSP VLYNQ Port User's Guide*** describes the VLYNQ port in the TMS320DM647/DM648 Digital Signal Processor (DSP). The VLYNQ port is a high-speed point-to-point serial interface for connecting to host processors and other VLYNQ compatible devices. It is a full-duplex serial bus where transmit and receive operations occur separately and simultaneously without interference.
- [SPRUJEM1](#)** ***TMS320DM647/DM648 DSP Video Port/VCXO Interpolated Control (VIC) Port User's Guide*** discusses the video port and VCXO interpolated control (VIC) port in the TMS320DM647/DM648 Digital Signal Processor (DSP). The video port can operate as a video capture port, video display port, or transport channel interface (TCI) capture port. The VIC port provides single-bit interpolated VCXO control with resolution from 9 bits to up to 16 bits. When the video port is used in TCI mode, the VIC port is used to control the system clock, VCXO, for MPEG transport channel.
- [SPRUJEM2](#)** ***TMS320DM647/DM648 DSP Serial Port Interface (SPI) User's Guide*** discusses the Serial Port Interface (SPI) in the TMS320DM647/DM648 Digital Signal Processor (DSP). This reference guide provides the specifications for a 16-bit configurable, synchronous serial peripheral interface. The SPI is a programmable-length shift register, used for high speed communication between external peripherals or other DSPs.
- [SPRUJEU6](#)** ***TMS320DM647/DM648 DSP Subsystem User's Guide*** describes the subsystem in the TMS320DM647/DM648 Digital Signal Processor (DSP). The subsystem is responsible for performing digital signal processing for digital media applications. The subsystem acts as the overall system controller, responsible for handling many system functions such as system-level initialization, configuration, user interface, user command execution, connectivity functions, and overall system control.
- [SPRUJF57](#)** ***TMS320DM647/DM648 DSP 3 Port Switch (3PSW) Ethernet Subsystem User's Guide*** describes the operation of the 3 port switch (3PSW) ethernet subsystem in the TMS320DM647/DM648 Digital Signal Processor (DSP). The 3 port switch gigabit ethernet subsystem provides ethernet packet communication and can be configured as an ethernet switch (DM648 only). It provides the serial gigabit media independent interface (SGMII), the management data input output (MDIO) for physical layer device (PHY) management.

3 Device Configuration

3.1 System Module Registers

The system module includes status and control registers required for configuration of the device. Brief descriptions of the various registers are shown in [Table 3-1](#). System Module registers required for device configuration are described in the following sections.

Table 3-1. System Module Register Memory Map

HEX ADDRESS RANGE	REGISTER NAME	DESCRIPTION
0x0204 9000	PINMUX	Pin multiplexing control 0
0x0204 9004	Reserved	Reserved
0x0204 9008	DSPBOOTADDR	Boot Address of DSP, decoded by bootloader software for host boots
0x0204 900C	BOOTCMPLT	Boot Complete
0x0204 9010		Reserved
0x0204 9014	BOOTCFG	Device boot configuration
0x0204 9018	JTAGID	Device ID number. See Section 6.25 for details.
0x0204 901C	PRI_ALLOC	Bus master priority control. See Section 4 for details
0x0204 9020 - 0x0204 9053	Reserved	Reserved
0x0204 9054	KEY_REG	Key Register to protect against accidental writes.
0x0204 9060 - 0x0204 90A7	Reserved	Reserved
0x0204 90A8	CFGPLL	CFGPLL inputs for SerDes
0x0204 90AC	Reserved	Reserved
0x0204 90B0	CFGRX0	Configure SGMII0 RX ⁽¹⁾
0x0204 90B4	CFGRX1	Configure SGMII1 RX ⁽¹⁾
0x0204 90B8	CFGTX0	Configure SGMII0 TX ⁽¹⁾
0x0204 90BC	CFGTX1	Configure SGMII1 TX ⁽¹⁾
0x0204 90C0	Reserved	Reserved
0x0204 90C4	MAC_ADDR_R0	MAC Address Read Only Register 0
0x0204 90C8	MAC_ADDR_R1	MAC Address Read Only Register 1
0x0204 90CC	MAC_ADDR_RW0	MAC Address Read/Write Register 0
0x0204 90D0	MAC_ADDR_RW0	MAC Address Read/Write Register 1
0x0204 90D4	ESS_LOCK	Ethernet Sub System Lock Register

(1) See the *TMS320DM647/DM648 DSP Ethernet Subsystem User's Guide Reference Guide* (literature number [SPRUF57](#)) for details.

3.2 Bootmode Registers

The BOOTCFG and DSPBOOTADDR registers are described in the following sections. At reset, the status levels of various pins required for proper boot are stored within these registers.

3.2.1 Boot Configuration (BOOTCFG) Register

Configuration pins latched at reset are presented in the BOOTCFG register accessible through the system module. This is a read-only register. The bits show the true latched value of the corresponding input at $\overline{\text{RESET}}$ or $\overline{\text{POR}}$ deassertion. This is desirable since the most important use of this MMR is for the user to debug/view the actual value driven on the pins during device reset.

Figure 3-1. BOOTCFG Register

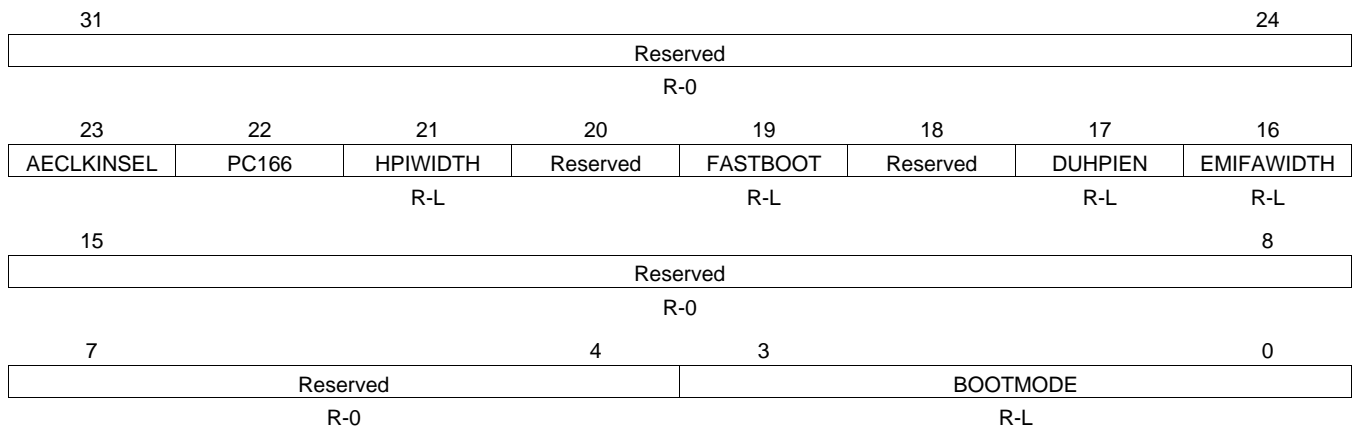

LEGEND: R/W = Read/Write; R = Read only; -n = value after reset

Table 3-2. BOOTCFG Register Field Descriptions

Bit	Field	Value	Description
31:24	Reserved		Reserved
23	AECLKINSEL	1 0	Controls the clock input for EMIFA. Latched from AECLKINSEL at $\overline{\text{RESET}}$ or $\overline{\text{POR}}$ deassertion EMIFA clocked from internal SYSCLK EMIFA clocked from outside from AECLKIN
22	PCI66	0 1	Controls PCI speed. PCI. Latched from PCI66 at $\overline{\text{RESET}}$ or $\overline{\text{POR}}$ deassertion 33 MHz PCI 66 MHz
21	HPIWIDTH	0 1	Controls HPI bus width. Latched from HPIWIDTH at $\overline{\text{RESET}}$ or $\overline{\text{POR}}$ deassertion 16 bit 32 bit
20	Reserved	1	Reserved
19	FASTBOOT	0 1	Fast Boot. Latched from FASTBOOT at $\overline{\text{RESET}}$ or $\overline{\text{POR}}$ deassertion No Fast Boot Fast Boot
18	Reserved		Reserved
17	DUHPIEN	0 1	PCI Enable Default. Latched from UHPIEN at $\overline{\text{RESET}}$ or $\overline{\text{POR}}$ deassertion UHPI disabled UHPI enabled
16	EMIFAWIDTH	0 1	EMIFA CS2 Bus Width Default. Latched from EMIFAWIDTH at $\overline{\text{RESET}}$ or $\overline{\text{POR}}$ deassertion 8-bit 16-bit
15:4	Reserved		Reserved

Table 3-2. BOOTCFG Register Field Descriptions (continued)

Bit	Field	Value	Description
3:0	BOOTMODE		Boot Mode. Latched from Bootmode at RESET or POR deassertion

Table 3-3. Boot Modes

DEVICE BOOT AND CONFIGURATION PINS			BOOT DESCRIPTION ^{(1) (2)}	DM647, DM648 (MASTER/SLAVE)	DSPBOOTADDR (DEFAULT)
BOOTMODE[3:0]	UHPIEN	FASTBOOT			
0000	0 or 1	0 or 1	No boot (emulation boot)	-	0x0080 0000
0001	0	1	PCI boot no auto-initialization	Slave	0x0080 0000
	1	0 or 1	HPI boot	Slave	0x0080 0000
0010	0	1	PCI boot with auto-initialization	Slave	0x0080 0000
	1	0 or 1	HPI boot	Slave	0x0080 0000
0011	0 or 1	0	UART boot with no hardware flow control	Slave	0x0080 0000
0100	0 or 1	0	EMIFA ROM direct boot (PLL bypass mode)	Master	0xA000 0000
		1	EMIFA ROM AIS boot	Master	0x0080 0000
0101	0 or 1	0 or 1	I2C Boot (standard mode)	Master	0x0080 0000
0110	0 or 1	0 or 1	SPI boot	Master	0x0080 0000
0111	0 or 1	0 or 1	Reserved	-	0x0080 0000
1000	0 or 1	0 or 1	SGMII0 - Boot port, no packet forwarding	Slave	0x0080 0000
1001	0 or 1	0 or 1	SGMII0 - Boot port, SGMII1 packet forwarding (reserved in DM647)	Slave	0x0080 0000
1010	0 or 1	0 or 1	SGMII1 - Boot port, SGMII0 packet forwarding (reserved in DM647)	Slave	0x0080 0000
1011	0 or 1	0 or 1	Reserved	-	0x0080 0000
1100	0 or 1	0 or 1	Reserved	-	0x0080 0000
1101	0 or 1	0 or 1	Reserved	-	0x0080 0000
1110	0 or 1	0	UART Boot with hardware flow control [UART0]	Slave	0x0080 0000
1111	0 or 1	0 or 1	Reserved	-	0x0080 0000

(1) In all bootmodes other than EMIFA ROM Direct Boot (BOOTMODE[3:0] = 0100b, UHPIEN = 0b or 1b, FASTBOOT = 0b) all C64x+ cache is disabled (L1P,L1D,L2).

(2) For details of the boot process, see *Using the TMS320DM647 Bootloader* Application Report (literature number [SPRAAJ1](#)).

3.2.2 DSPBOOTADDR Register Description

The DSPBOOTADDR register contains the upper 22 bits of the C64x+ DSP reset vector. The register format is shown in [Figure 3-2](#) and bit field descriptions are shown in [Table 3-4](#). DSPBOOTADDR is readable and writable by software after reset. DSPBOOTADDR Decode: This decode logic determines the default of the DSPBOOTADDR Register. It can default to the base address of L2 ROM (0x00800000) or the base address of EMIFA CS2 (0xA0000000).

Figure 3-2. DSPBOOTADDR Register

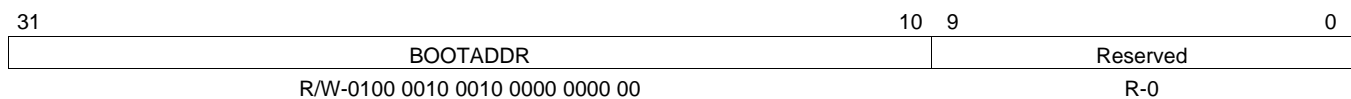

LEGEND: R/W = Read/Write; R = Read only; -n = value after reset

Table 3-4. DSPBOOTADDR Register Field Descriptions

Bit	Field	Value	Description
31:10	BOOTADDR		Upper 22 bits of the C64x+ DSP bootmode address
9:0	Reserved		Reserved

3.2.3 Boot Complete (BOOTCMPLT) register

The BOOTCMPLT register contains a BC (boot complete) field in bit 0, and a ERR (boot error) field in bits 19:16.

The BC field is written by the external host to indicate that it has completed boot. In the bootloader code, the CPU can poll for this bit. Once this bit = 1, the CPU can begin executing from DSPBOOTADDR.

The ERR field is written by the bootloader software if the software detects a boot error. Coming out of a boot, application software can read this field to determine if boot was accomplished. Actual error code is determined by software.

Figure 3-3. BOOTCMPLT Register 3

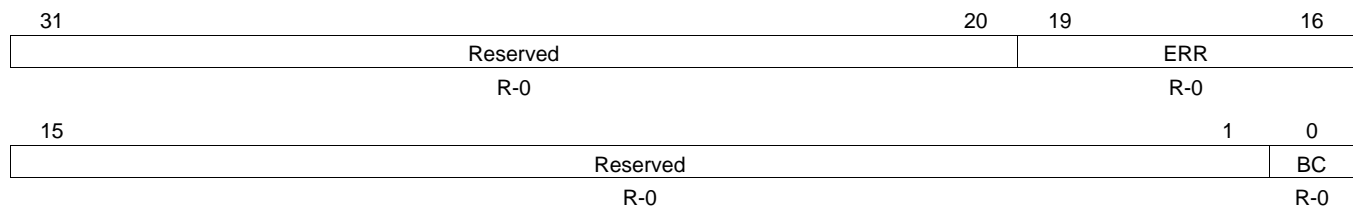

LEGEND: R/W = Read/Write; R = Read only; -n = value after reset

Table 3-5. BOOTCMPLT Register Field Descriptions

Bit	Field	Value	Description
31:20	Reserved		Reserved
19:16	ERR	0000 0001 – 1111	Boot error No error Bootloader software detected boot error. For details on boot errors, see the <i>Using the TMS320DM647/DM648 Bootloader</i> Application Report (literature number SPRAAJ1).
15:1	Reserved		Reserved
0	BC	0 1	Boot Complete Flag from host. This is applicable only to host boots. Host has not completed booting this device. Host has completed booting this device and the DSP can begin executing from DSPBOOTADDR.

3.2.4 Priority Allocation (PRI_ALLOC)

Each of the masters (excluding the C64x+ Megamodule) is assigned a priority via the Priority Allocation Register (PRI_ALLOC), see [Figure 3-4](#). The priority is enforced when several masters in the system are vying for the same endpoint. A value of 000b has the highest priority, while 111b has the lowest priority.

Note that the configuration SCR port on the data SCR is considered a single endpoint meaning priority will be enforced when multiple masters try to access the configuration SCR. Priority is also enforced on the configuration SCR side when a master (through the data SCR) tries to access the same endpoint as the C64x+ Megamodule.

The Ethernet Subsystem and VLYNQ fields specify the priority of the Ethernet Subsystem and VLYNQ peripherals, respectively. Similarly, the HOST field applies to the priority of the HPI and PCI peripherals. Other master peripherals are not present in the PRI_ALLOC register as they have their own registers to program their priorities. For more information on the default priority values in these peripheral registers, see the device-compatible peripheral reference guides.

TI recommends that these priority registers be reprogrammed during device initialization.

Table 3-6. Default Master Priorities

MASTER	DEFAULT PRIORITY
EDMA3TC0	0 (EDMA CC QUEPRI Register)
EDMA3TC1	0 (EDMA CC QUEPRI Register)
EDMA3TC2	0 (EDMA CC QUEPRI Register)
EDMA3TC3	0 (EDMA CC QUEPRI Register)
64x+_DMAP	7 (C64x+ MDMAARBE.PRI Register bit field)
64x+_CFGP	1 (C64x+ MDMAARBE.PRI Register bit field)
Ethernet Subsystem	3 (PRI_ALLOC register)
VLYNQ	4 (PRI_ALLOC register)
UHPI	4 (PRI_ALLOC register)
PCI	4 (PRI_ALLOC register)
VICP	5 (PRI_ALLOC register)

Figure 3-4. Priority Allocation Register (PRI_ALLOC)

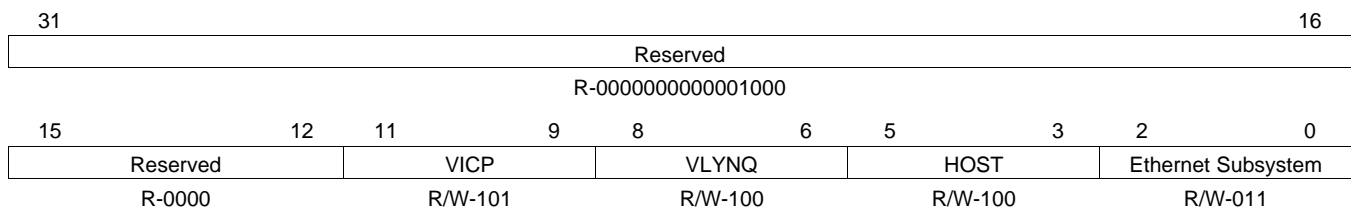

LEGEND: R/W = Read/Write; R = Read only; -n = value after reset

3.2.5 KEY_REG (write protection)

KEY_REG protects against accidental writes to certain system configuration registers. The complete set of registers protected by the KEY_REG is:

- PINMUX
- BOOTCFG
- PRI_ALLOC
- CFGPLL
- CFGRX0
- CFGTX0
- CFGRX1
- CFGTX1
- MAC_ADDR_RW0
- MAC_ADDR_RW1

Writes to these registers are locked/blocked by default. To enable writes to these registers, write 0xADDDECAF to the KEY_REG. After enabling writes to protected registers by doing the above, the register writes should occur within 10000 CPU/6 cycles, after which the key will be reset.

Figure 3-5. KEY_REG

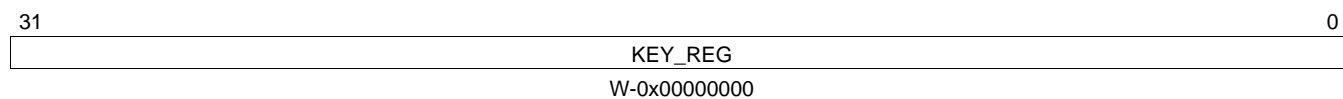

LEGEND: R/W = Read/Write; R = Read only; -n = value after reset

3.2.6 PINMUX Register

All pin multiplexing options are controlled by software via PINMUX register (except the ones mentioned in Table 3-8, whose default is selected by configuration pins). This PINMUX register reside within the system module portion of the CFG bus memory map. The format of the registers and a description of the pins they control are in the following sections.

The PINMUX Register controls all the software-controlled pin muxing. The register format is shown in Figure 3-6. A brief description of each field is shown in Table 3-7.

Figure 3-6. PINMUX Register

31										22		21	20		19		18	17		16							
Reserved										GPIO_EN		Reserved		VPI_EN													
R-0000 0000 00										R/W-00		R-00		R/W-00													
15		14		13		12		11		10		9		8		7		6		5		4		3		1	0
VP34_EN		SPI_UART_EN		Reserved		MCASP_EN		Reserved		VLYNQ_EN		Reserved		TIMER_EN													
R/W-00		R/W-00		R-00		R/W-00		R-00		R/W-00		R-000		R/W-0													

LEGEND: R/W = Read/Write; R = Read only; -n = value after reset

Table 3-7. PINMUX Register Field Descriptions

Bit	Field	Value	Description
31:22	Reserved		Reserved
21:20	GPIO_EN		Controls the pin muxing between Video Port 0 and the GPIO[12:15]
			UNMUXED ⁽¹⁾ UNMUXED ⁽²⁾ SECONDARY MUXED ⁽³⁾
			.VP0D16-19 VP0D02-09/CLK/CTL VP0D12-15 GP12-15
		00	3-state 3-state 3-state
		01	3-state 3-state 3-state
		10	Enable Enable VP0D12-15
	11	3-state Enable GP12-15	
19:18	Reserved		Reserved
17:16	VP1_EN		Controls the pin muxing between Video Port 1 and GPIO[16:31]
			UNMUXED ⁽⁴⁾ MUXED ⁽⁵⁾
			VP1CLK0-1/VP1CTL0-2 VP1 Data (V1D02-09/12-19) GP[16-31]
		00	3-state 3-state
		01	3-state 3-state
		10	3-state GP16-31
	11	Enable VP1D02-09 and VP1D12-19	

(1) The complete list of pins: U20, U21, U22, R18.
 (2) The complete list of pins: Y23, V23, Y22, V22, U23, W20, V18, U18, V19, W21, T18, U19, V20.
 (3) The complete list of pins: V21, T19, T20, T21.
 (4) The complete list of pins: P23, N23, R23, P22, N22
 (5) The complete list of pins: R19, P19, P18, R22, R21, R20, N21, N20, N19, P21, P20, M20, M18, N18, M21, M19

Table 3-7. PINMUX Register Field Descriptions (continued)

Bit	Field	Value	Description
15:14	VP34_EN		Controls the pin muxing between Video Port 3-4 and EMIFA ⁽⁶⁾
			UNMUXED ⁽⁷⁾
			MUXED ⁽⁸⁾
			VP4D05/VP4CLK1
			VP3/VP4
			EMIFA
	00	3-state	3-state
	01	3-state	3-state
	10	Disable	EMIFA
	11	Enable	VP3/VP4
13:12	SPI_UART_EN		Controls the pin muxing between SPI and UART
			UNMUXED ⁽⁹⁾
			MUXED ⁽¹⁰⁾
			SPICLK
			SPI or UART
			00
	01	Enable	SPI
	10	Disable	UART
	11	Enable	SPIDI SPIDO UART_TX UART_RX
11:10	Reserved		Reserved

(6) The value of VP34_EN depends on the BOOTMODE[3:0] pin value at reset. If the BOOTMODE[3:0] is 0100, the VP3/4 and the EMIFA mux defaults to EMIFA enable (the value is 10b).

(7) The complete list of pins: K1, M6.

(8) The complete list of pins: T1, P1, T2, R1, P2, T6, T5, T4, T3, R6, R5, R4, R3, R2, P6, P5, P4, P3, N4, N6, N5, L1, J2, J1, K2, L2, M4, M5, L3, L4, L5, K3, K4, L6, K5, J3, J4, J5, J6, K6.

(9) The complete list of pin:F22

(10) The complete list of pins: D23, F23, G23, F21

Table 3-7. PINMUX Register Field Descriptions (continued)

Bit	Field	Value	Description	
9:8	MCASP_EN		Controls the pin muxing between McASP and VIC	
			UNMUXED	MUXED ⁽¹¹⁾
				STCLK, VCTL, or McASP
		00		3-state
		01		McASP (all McASP Pins)
		10		(McASP without AXR8, AXR9)
				ACLKR
				AFSR
				AXR0
				AXR1
				AC:LKX
				AFSX
				AXR2
				AXR3
				AHCLKR
				AMUTEIN
				AXR4
	AXR5			
	AHCLKX			
	AMUTE			
	AXR6			
	AXR7			
	STCLK			
	VCTL			
11		Reserved		
7:6	Reserved		Reserved	
5:4	VLYNQ_EN		Controls the pin muxing between Video Port 2 and VLYNQ	
			UNMUXED ⁽¹²⁾	MUXED ⁽¹³⁾
			VP2#1	VP2#2 VLYNQ
		00		3-state
		01		3-state
		10		Enable
11		Enable	VRXD0-3 and VTXD0-3, VCLK, VSCRUN	
3:1	Reserved		Reserved	
0	TIMER_EN		Controls the pin muxing between TIMER and GPIO[8:11]	
				MUXED ⁽¹⁴⁾
		0		GPIO[8:11]
1		Timer 0/1		

(11) The complete list of pins: AC4, AC3, AC6, AC7, W6, AA7, AB6, Y6, AA6, AB4, Y5, V7, AA4, V6, Y7, AA5, AB3, U7
(12) For the first half of the Video Port 2, the complete list of pins with function: AB1(VP2CLK0), AA1 (VP2CTL0), AB2 (VP2CTL1) and W5, AA2, Y3, U6, Y2, W3, V5, W4 (VP2D02, VP2D03, VP2D04, VP2D05, VP2D06, VP2D07, VP2D08, VP2D09)
(13) For the second half of the Video Port 2, the complete list of pins with function: W1 (VP2CLK1/VCLK), Y1(VP2CTL2/VSCRUN), W2, V3, V4, U1, U3, U2, U5, U4 (VP2D12/VRXD0, VP2D13/VRXD1, VP2D14/VRXD2, VP2D15/VRXD3, VP2D16/VTXD0, VP2D17/VTXD1, VP2D18/VTXD2, VP2D19/VTXD3)
(14) The complete list of pins: E20, D21, E21, C22

Table 3-8. PCI/UHPI/GPIO Block: PCI MUXed With UHPI and GPIO[0:7]

	MUXED ⁽¹⁾	
	PCI	UHPI/GPIO[0:7]
UHPIEN (pin)		
1	UHPI/GPIO[0:7]	
0	PCI	

(1) The complete list of pin:AA22, AB22, AC21, AA23, AC22, AB21, AA21, Y21, AB20, AA20, Y20, Y19, AB18, AA19, AC18, AA18, Y16, AB15, AA15, Y15, W15, V15, AC14, AB14, W14, V14, AC13, AB13, AA13, Y13, W13, V13, W19, Y18, Y17, W17, W18, AC20, AC17, W16, Y14, AC15, AA16, AB17, U13, U12, V12, AA12, AA17, AA14.

For information on the Ethernet Subsystem registers, see the *TMS320DM647/DM648 DSP Subsystem Reference Guide* (literature number [SPRUEU6](#)).

3.2.7 MAC Address Registers

- MAC_ADDR_R0
- MAC_ADDR_R1
- MAC_ADDR_RW0
- MAC_ADDR_RW1

Two sets of registers provide default MAC addresses for the device. One set - MAC_ADDR_R0 and MAC_ADDR_R1 - is read only and the other set - MAC_ADDR_RW0 and MAC_ADDR_RW1 - includes read and write registers.

Figure 3-7. MAC_ADDR_R0 Register

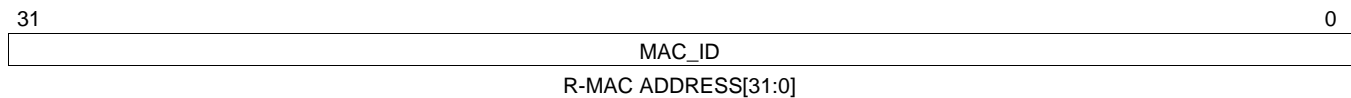

LEGEND: R/W = Read/Write; R = Read only; -n = value after reset

Table 3-9. MAC_ADDR_R0 Register Field Descriptions

Bit	Field	Value	Description
31:0	MAC_ID	Mac Address[31:0] of the device	Bit 0 of MAC_ID is bit 0 of MAC Address

Figure 3-8. MAC_ADDR_R1 Register

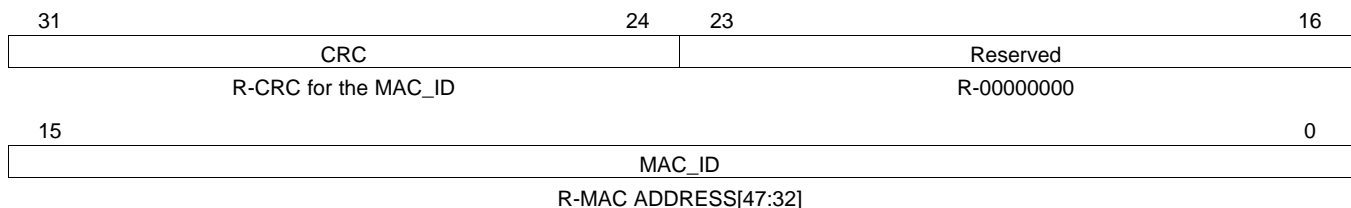

LEGEND: R/W = Read/Write; R = Read only; -n = value after reset

Table 3-10. MAC_ADDR_R1 Register Field Descriptions

Bit	Field	Value	Description
31:24	CRC	CRC of the MAC ID	This field will hold the CRC of the MAC address of that particular device.
23:16	Reserved	0x00	Reserved

Table 3-10. MAC_ADDR_R1 Register Field Descriptions (continued)

Bit	Field	Value	Description
15:0	MAC_ID	Mac Address[47:32] of the device	Bit 0 of MAC_ID is Bit 32 of MAC Address

Figure 3-9. MAC_ADDR_RW0 Register

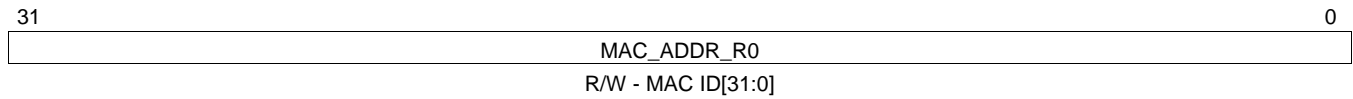

LEGEND: R/W = Read/Write; R = Read only; -n = value after reset

Table 3-11. MAC_ADDR_RW0 Register Field Descriptions

Bit	Field	Value	Description
31:0	MAC_ID	Mac Address[31:0] of the device	Bit 0 of MAC_ID is bit 0 of MAC Address

Figure 3-10. MAC_ADDR_RW1 Register

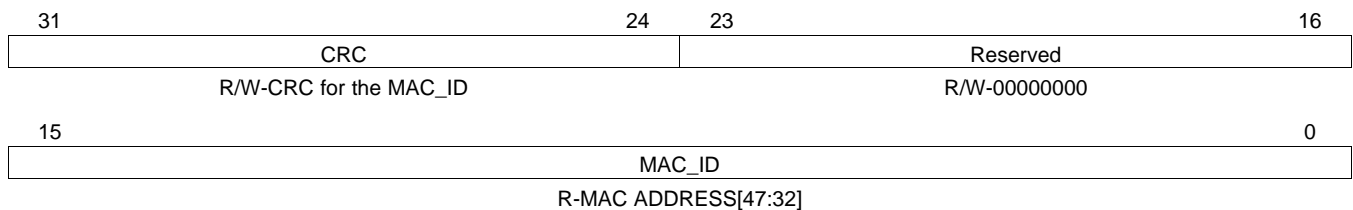

LEGEND: R/W = Read/Write; R = Read only; -n = value after reset

Table 3-12. MAC_ADDR_RW1 Register Field Descriptions

Bit	Field	Value	Description
31:24	CRC	CRC of the MAC ID	This field will hold the CRC of the MAC address of that particular device.
23:16	Reserved	0x00	Reserved
15:0	MAC_ID	Mac Address[47:32] of the device	Bit 0 of MAC_ID is Bit 32 of MAC Address

3.3 Pullup/Pulldown Resistors

Proper board design should specify that input pins to the device always be at a valid logic level and not floating. This may be achieved via pullup/pulldown resistors. The device features internal pullup (IPU) and internal pulldown (IPD) resistors on most pins to eliminate the need, unless otherwise noted, for *external* pullup/pulldown resistors.

An external pullup/pulldown resistor must be used in the following situations:

- *Boot and Configuration Pins:* If the pin is both routed out and in high-impedance mode, an external pullup/pulldown resistor *must* be used, even if the IPU/IPD matches the desired value/state.
- *Other Input Pins:* If the IPU/IPD *does not* match the desired value/state, use an external pullup/pulldown resistor to pull the signal to the opposite rail.

If the boot and configuration pins are both routed out and in high-impedance mode, it is recommended that an external pullup/pulldown resistor be used. Although internal pullup/pulldown resistors exist on these pins and they may match the desired configuration value, providing external connectivity can help specify that valid logic levels are latched on these important boot configuration pins. In addition, applying external pullup/pulldown resistors on the boot and configuration pins adds convenience to the user in debugging and flexibility in switching operating modes.

Tips for choosing an external pullup/pulldown resistor:

- Select a resistor with the largest possible resistance
- Calculate the worst-case leakage current that flows through this external resistor. Worst-case leakage current can be calculated by adding up all the leakage current at the pin—e.g., the input current (I_I) from the device, and leakage current from the other device(s) to which this pin is connected.
- Specify that the voltage at the pin stays well within the low-/high-level input voltages (V_{IL} or V_{IH}) when worst-case leakage current is flowing through this external resistor.
 - To oppose an IPU and pull the signal to a logic low, the voltage at the pin must stay well below V_{IL} .
 - To oppose an IPD and pull the signal to a logic high, the voltage at the pin must stay well above V_{IH} .

For most systems, a 1-k Ω resistor can be used to oppose the IPU/IPD while meeting the above criteria. Users should confirm this resistor value is correct for their specific application.

For most systems, a 20-k Ω resistor can be used to complement the IPU/IPD on the boot and configuration pins while meeting the above criteria. Users should confirm this resistor value is correct for their specific application.

For more detailed information on input current (I_I), and the low-/high-level input voltages (V_{IL} and V_{IH}), see [Section 5.3, Electrical Characteristics Over Recommended Ranges of Supply Voltage and Operating Temperature](#).

For the internal pullup/pulldown resistors for all device pins, see the peripheral/system-specific terminal functions table.

4 System Interconnect

The C64x+ Megamodule, the EDMA3 transfer controllers, and the system peripherals are interconnected through two switch fabrics. The switch fabrics allow for low-latency, concurrent data transfers between master peripherals and slave peripherals. Through a switch fabric, the CPU can send data to the video ports without affecting a data transfer between the PCI and the DDR2 memory controller. The switch fabrics also allow for seamless arbitration between the system masters when accessing system slaves.

4.1 Internal Buses, Bridges, and Switch Fabrics

Two types of buses exist in the device: data buses and configuration buses. Some device peripherals have both a data bus and a configuration bus interface, while others only have one type of interface. Furthermore, the bus interface width and speed varies from peripheral to peripheral. Configuration buses are mainly used to access the register space of a peripheral and the data buses are used mainly for data transfers. However, in some cases, the configuration bus is also used to transfer data. For example, data is transferred to the UART or I2C via their configuration bus. Similarly, the data bus can also be used to access the register space of a peripheral. For example, the EMIFA and DDR2 memory controller registers are accessed through their data bus interface.

The C64x+ Megamodule, the EDMA3 traffic controllers, and the various system peripherals can be divided into two categories: masters and slaves. Masters are capable of initiating read and write transfers in the system and do not rely on the EDMA3 for their data transfers. Slaves, on the other hand, rely on the EDMA3 to perform transfers to and from them. Masters include the EDMA3 traffic controllers and PCI. Slaves include the McASP, video ports, and I2C.

The device contains two switch fabrics through which masters and slaves communicate. The data switch fabric, known as the data switched central resource (SCR), is a high-throughput interconnect mainly used to move data across the system (for more information, see [Section 4.2](#)). The data SCR connects masters to slaves via 128-bit data buses running at a SYSCLK1 frequency (SYSCLK1 is generated from PLL1 controller). Peripherals that have a 128-bit data bus interface running at this speed can connect directly to the data SCR; other peripherals require a bridge.

The configuration switch fabric, also known as the configuration switch central resource (SCR) is mainly used by the C64x+ Megamodule to access peripheral registers (for more information, see [Section 4.3](#)). The configuration SCR connects the C64x+ Megamodule to slaves via 32-bit configuration buses running at a SYSCLK1 frequency (SYSCLK1 is generated from the PLL1 controller). As with the data SCR, some peripherals require the use of a bridge to interface to the configuration SCR. Note that the data SCR also connects to the configuration SCR. Bridges perform a variety of functions:

- Conversion between configuration bus and data bus.
- Width conversion between peripheral bus width and SCR bus width
- Frequency conversion between peripheral bus frequency and SCR bus frequency

For example, the EMIFA memory controller require a bridge to convert their 64-bit data bus interface into a 128-bit interface so that they can connect to the data SCR.

Some peripherals can be accessed through the data SCR and also through the configuration SCR.

4.2 Data Switch Fabric Connections

[Figure 4-1](#) shows the connection between slaves and masters through the data switched central resource (SCR). Masters are shown on the right and slaves on the left. The data SCR connects masters to slaves via 128-bit data buses running at a SYSCLK1 frequency. SYSCLK1 is supplied by the PLL1 controller and is fixed at a frequency equal to the CPU frequency divided by 3. Some peripherals, like PCI and the C64x+ Megamodule, have both slave and master ports. Each EDMA3 transfer controller has an independent connection to the data SCR.

Masters can access the configuration SCR through the data SCR. The configuration SCR is described in [Section 4.3](#).

Not all masters on the device may connect to all slaves. Allowed connections are summarized in [Table 4-1](#).

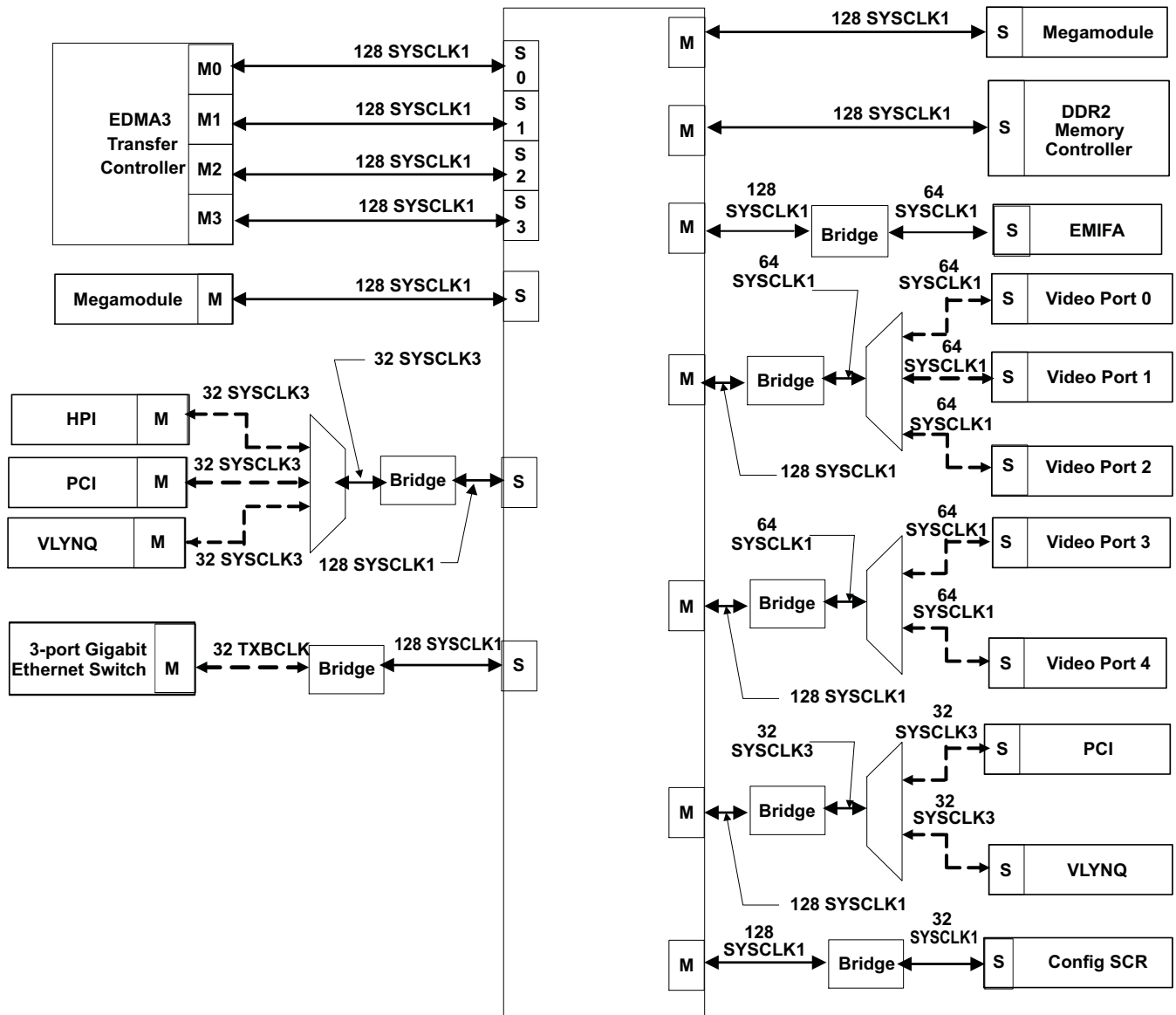

Figure 4-1. Data SCR

Table 4-1. Connectivity Matrix for Data SCR

	MEGAMODULE	DDR2 EMIF	EMIFA	VIDEO PORT 0-2	VIDEO PORT 3-4	PCI	VLYNQ	Configuration SCR
TC0	Y	Y	Y	Y	Y	Y	Y	Y
TC1	Y	Y	Y	Y	Y	Y	Y	Y
TC2	Y	Y	Y	Y	Y	Y	Y	Y
TC3	Y	Y	Y	Y	Y	N	N	N
Megamodule	N	Y	Y	N	N	Y	Y	N
HPI	Y	Y	Y	N	N	Y	Y	Y
PCI	Y	Y	Y	N	N	Y	Y	Y
VLYNQ	Y	Y	Y	N	N	Y	Y	Y
Ethernet Subsystem	Y	Y	Y	N	N	N	N	N

4.3 Configuration Switch Fabric

Figure 4-2 shows the connection between the C64x+ megamodule and the configuration SCR, which is mainly used by the C64x+ Megamodule to access peripheral registers. The data SCR also has a connection to the configuration SCR that allows masters to access most peripheral registers. The only registers not accessible by the data SCR through the configuration SCR are the device configuration registers and the PLL1 and PLL2 controller registers; these can be accessed only by the C64x+ Megamodule. The configuration SCR uses 32-bit configuration buses running at SYSCLK1 frequency. SYSCLK1 is supplied by the PLL1 controller and is fixed at a frequency equal to the CPU frequency divided by 3.

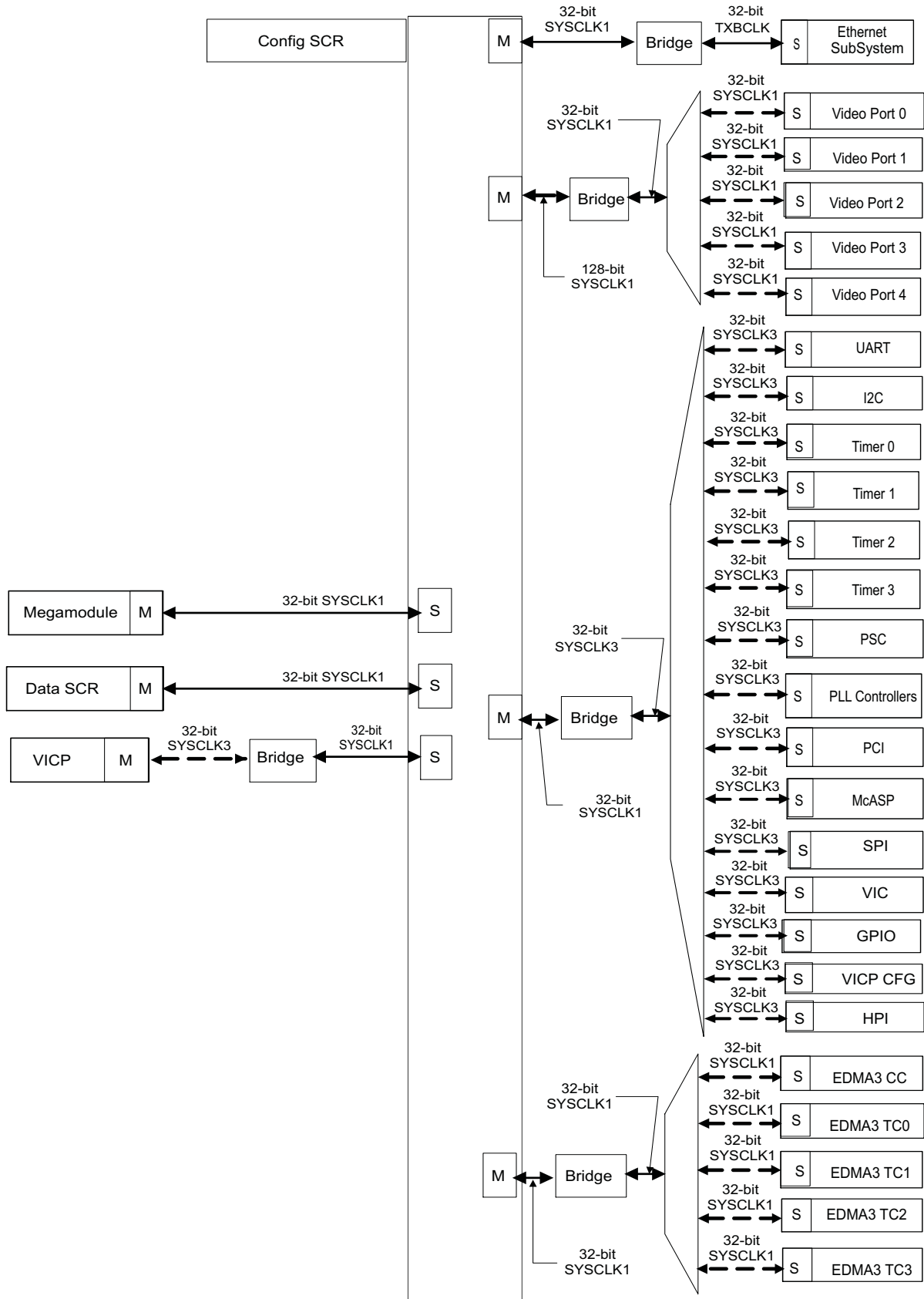

Figure 4-2. Configuration SCR

5 Device Operating Conditions

5.1 Absolute Maximum Ratings

Over Operating Temperature Range (Unless Otherwise Noted)⁽¹⁾

Supply voltage ranges:	Core (CV _{DD} , CV _{DDESS} , CV _{DD1} , AV _{DDA} , DV _{DDD} , AV _{DDT}) ⁽²⁾	1.20-V operation	-0.5 V to 1.5 V
	I/O, 3.3V (DV _{DD33}) ⁽²⁾		-0.5 V to 4.2 V
	I/O, 1.8V (DV _{DD18} , AV _{DLL1} , AV _{DLL2} , AV _{DDR}) ⁽²⁾		-0.5 to 2.5 V
Input voltage ranges:	V _I I/O, 3.3-V pins		-0.5 V to 4.2 V
	V _I I/O, 1.8 V		-0.5 V to 2.5 V
Output voltage ranges:	V _O I/O, 3.3-V pins		-0.5 V to 4.2 V
	V _O I/O, 1.8 V		-0.5 V to 2.5 V
Operating case temperature, T _{case}	Commercial		0°C to 90°C
	Extended		-40°C to 105°C
	Industrial		-40°C to 90°C
Storage temperature range, T _{stg}	(default)		-65°C to 150°C

- (1) Stresses beyond those listed under *absolute maximum ratings* may cause permanent damage to the device. These are stress ratings only, and functional operation of the device at these or any other conditions beyond those indicated under *recommended operating conditions* is not implied. Exposure to absolute-maximum-rated conditions for extended periods may affect device reliability.
- (2) All voltage values are with respect to V_{SS}.

5.2 Recommended Operating Conditions

		MIN	NOM	MAX	UNIT
CV _{DD}	Supply voltage, Core ⁽¹⁾	(-720, -800, -900, -1100 devices)	1.2	1.26	V
CV _{DDESS}	Supply voltage, Ethernet Subsystem Core ⁽¹⁾				
CV _{DD1}	Supply voltage, DDR Core ⁽¹⁾				
AV _{DDA}	Supply voltage, SerDes Analog ⁽¹⁾				
DV _{DDD}	Supply voltage, SerDes Digital ⁽¹⁾				
AV _{DDT}	Supply voltage, SerDes Analog ⁽¹⁾				
DV _{DD33}	Supply voltage, I/O, 3.3 V	3.14	3.3	3.46	V
DV _{DD18}	Supply voltage, DDR I/O, 1.8 V	1.71	1.8	1.89	V
AV _{DLL1}	Supply voltage, I/O, 1.8 V				
AV _{DLL2}	Supply voltage, I/O, 1.8 V				
AV _{DDR}	Supply voltage, 1.8-V SerDes Analog Supply (Regulator)				
V _{SS}	Supply ground (V _{SS})	0	0	0	V
DDR_VREF	DDR2 reference voltage ⁽²⁾	0.49DV _{DD18}	0.5DV _{DD18}	0.51DV _{DD18}	V
V _{IH}	High-level input voltage, 3.3 V (except PCI-capable and I2C pins)	2			V
	High-level input voltage, I2C	0.7DV _{DD33}			V
	PCI-capable pins	0.5DV _{DD33}		DV _{DD33} + 0.5	V
	DDR2 memory controller pins (DC)	DDR_VREF + 0.125		DV _{DD18} + 0.3	V
V _{IL}	Low-level input voltage, 3.3 V (except PCI-capable and I2C pins)	0.8			V
	Low-level input voltage, I2C	0		0.3DV _{DD33}	V
	PCI-capable pins	-0.5		0.3DV _{DD33}	V
	DDR2 memory controller pins (DC)	-0.3		DDR_VREF - 0.125	V
T _{case}	Operating case temperature	Commercial ⁽³⁾	0		90
		Extended ⁽⁴⁾	-40		105
		Industrial	-40		90
F _{SYCLK1}	DSP Operating Frequency (SYCLK1)	(-1100 devices) ⁽³⁾	33.3		1100
		(-900 devices)	33.3		900
		(-720 devices)	33.3		720
		(-800 devices)	33.3		800

- (1) Future variants of TI SOC devices may operate at voltages ranging from 0.9 V to 1.4 V to provide a range of system power/performance options. TI highly recommends that users design-in a supply that can handle multiple voltages within this range (i.e., 1.0 V, 1.05 V, 1.1 V, 1.14 V, 1.2, 1.26 V with ± 3% tolerances) by implementing simple board changes such as reference resistor values or input pin configuration modifications. Not incorporating a flexible supply may limit the system ability to easily adapt to future versions of TI SOC devices.
- (2) DDR_VREF is expected to equal 0.5DV_{DDR2} of the transmitting device and to track variations in the DV_{DD18}.
- (3) To avoid significant device degradation for 1.1GHz devices, the device power-on hours (POH) must be limited to less than 87.6K.
- (4) To avoid significant device degradation for extended temperature devices (- 40°C ≤ T_{case} ≤ 105°C), the device power-on hours (POH) must be limited to less than 50K.

5.3 Electrical Characteristics

Over Recommended Ranges of Supply Voltage and Operating Temperature (Unless Otherwise Noted)

PARAMETER		TEST CONDITIONS ⁽¹⁾	MIN	TYP	MAX	UNIT
V _{OH} High-level output voltage	3.3-V pins (except PCI-capable and I2C pins)	DV _{DD33} = MIN, I _{OH} = MAX	0.8DV _{DD33}			V
	PCI-capable pins(2)	DV _{DD33} = 3.3V, I _{OH} = -0.5 mA	0.9DV _{DD33}			
	DDR2 memory controller pins		1.4			
V _{OL} Low-level output voltage	3.3-V pins (except PCI-capable and I2C pins)	DV _{DD33} = MIN, I _{OL} = MAX			0.22DV _{DD33}	
	PCI-capable pins(2)	DV _{DD33} = 3.3V, I _{OL} = 1.5 mA			0.1DV _{DD33}	
	I2C pins	Pulled up to 3.3 V, 3 mA sink current			0.4	
	DDR2 memory controller pins				0.4	V
I _I Input current [dc]	3.3-V pins (except PCI-capable and I2C pins)	V _I = V _{SS} to DV _{DD33} without internal pullup or pulldown resistor	-1		1	μA
		V _I = V _{SS} to DV _{DD33} with internal pullup resistor ⁽²⁾	50	100	400	μA
		V _I = V _{SS} to DV _{DD33} with opposing internal pulldown resistor ⁽²⁾	-400	-100	-50	μA
	Input current [dc] (I2C)	0.1DV _{DD33} ≤ V _I ≤ 0.9DV _{DD33}	-10		10	μA
	PCI-capable pins(4)		-600		600	μA
I _{OH} High-level output current [dc]	All peripherals other than DDR2 and PCI				-8	mA
	DDR2 memory controller pins				-4	mA
	PCI-capable pins(2)				-0.5	mA
I _{OL} Low-level output current [dc]	All peripherals other than DDR2, PCI and I2C				8	mA
	I2C pins				3	mA
	DDR2 memory controller pins				4	mA
	PCI-capable pins(2)				1.5	mA
I _{OZ} I/O Off-state output current [DC]	3.3-V pins		-20		20	μA
I _{CDD}	Core (CV _{DD} , V _{DDA_1P1V}) supply current ⁽³⁾	CV _{DD} = 1.2-V, DSP clock = 720 MHz		2497		mA
		CV _{DD} = 1.2-V, DSP clock = 800 MHz		2605		mA
		CV _{DD} = 1.2-V, DSP clock = 900 MHz		2741		mA
		CV _{DD} = 1.2-V, DSP clock = 1100 MHz		3013		mA
I _{DDD}	3.3-V I/O (DV _{DD33}) supply current ⁽³⁾	DV _{DD} = 3.3-V, DSP clock = 720 MHz, 800 MHz, 900 MHz, 1100 MHz		227		mA
	1.8-V I/O (DV _{DDR2} , DDR_VDDLL, PLLV _{PRW18} , V _{DDA_1P8V} , MXV _{DD}) supply current ⁽³⁾	DV _{DD} = 1.8-V, DSP clock = 720 MHz, 800 MHz, 900 MHz, 1100 MHz		311		mA
C _I	Input capacitance				10	pF
C _O	Output capacitance				10	pF

- (1) For test conditions shown as MIN, MAX, or NOM, use the appropriate value specified in the recommended operating conditions table.
- (2) Applies only to pins with an internal pullup (IPU) or pulldown (IPD) resistor.
- (3) Assumes the following conditions: 50% DSP CPU utilization; (peripheral configurations, other housekeeping activities) DDR2 at 50% utilization (266 MHz), 50% writes, 32 bits, 100% bit switching, 110-MHz Video Ports at 100% utilization, MCASP operating at 25 MHz with 100% utilization with 10 serializers, Timer0,1 at 100% utilization, VICP with 100% utilization, PCI operating at 66 MHz with 50% writes at room temp (25°C) using ZUT package. (as in the power appnote) for the three items.

6 Peripheral Information and Electrical Specifications

6.1 Parameter Information

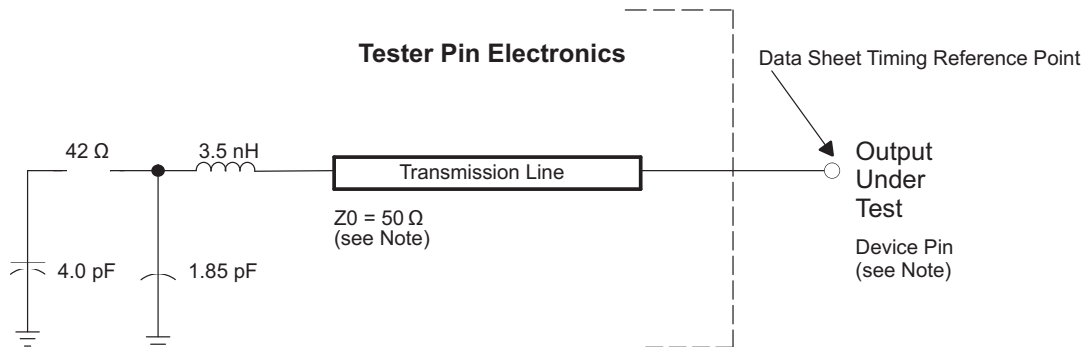

NOTE: The data sheet provides timing at the device pin. For output timing analysis, the tester pin electronics and its transmission line effects must be taken into account. A transmission line with a delay of 2 ns can be used to produce the desired transmission line effect. The transmission line is intended as a load only. It is not necessary to add or subtract the transmission line delay (2 ns) from the data sheet timings.

Input requirements in this data sheet are tested with an input slew rate of < 4 Volts per nanosecond (4 V/ns) at the device pin.

Figure 6-1. Test Load Circuit for AC Timing Measurements

The load capacitance value stated is only for characterization and measurement of ac timing signals. This load capacitance value does not indicate the maximum load the device is capable of driving.

6.1.1 3.3-V Signal Transition Levels

All input and output timing parameters are referenced to V_{ref} for both 0 and 1 logic levels. For 3.3-V I/O, $V_{ref} = 1.5$ V. For 1.8-V I/O, $V_{ref} = 0.9$ V.

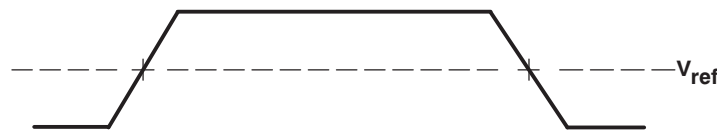

Figure 6-2. Input and Output Voltage Reference Levels for ac Timing Measurements

All rise and fall transition timing parameters are referenced to V_{IL} MAX and V_{IH} MIN for input clocks, V_{OL} MAX and V_{OH} MIN for output clocks.

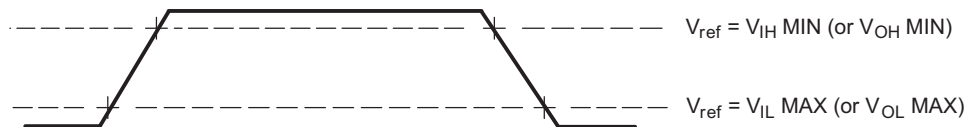

Figure 6-3. Rise and Fall Transition Time Voltage Reference Levels

6.1.2 3.3-V Signal Transition Rates

All timings are tested with an input edge rate of 4 volts per nanosecond (4 V/ns).

6.1.3 Timing Parameters and Board Routing Analysis

The timing parameter values specified in this data manual do *not* include delays caused by board routings. As a good board design practice, such delays must *always* be taken into account. Timing values may be adjusted by increasing/decreasing such delays. TI recommends utilizing the available I/O buffer information specification (IBIS) models to analyze the timing characteristics correctly. To properly use IBIS models to attain accurate timing analysis for a given system, see the *Using IBIS Models for Timing Analysis Application Report* (literature number [SPRA839](#)). If needed, external logic hardware such as buffers may be used to compensate for any timing differences.

For inputs, timing is most impacted by the round-trip propagation delay from the DSP to the external device and from the external device to the DSP. This round-trip delay tends to negatively impact the input setup time margin, but also tends to improve the input hold time margins (see [Table 6-1](#) and [Figure 6-4](#)).

[Figure 6-4](#) represents a general transfer between the DSP and an external device. The figure also represents board route delays and how they are perceived by the DSP and the external device.

Table 6-1. Board-Level Timing Example
(see [Figure 6-4](#))

NO.	DESCRIPTION
1	Clock route delay
2	Minimum DSP hold time
3	Minimum DSP setup time
4	External device hold time requirement
5	External device setup time requirement
6	Control signal route delay
7	External device hold time
8	External device access time
9	DSP hold time requirement
10	DSP setup time requirement
11	Data route delay

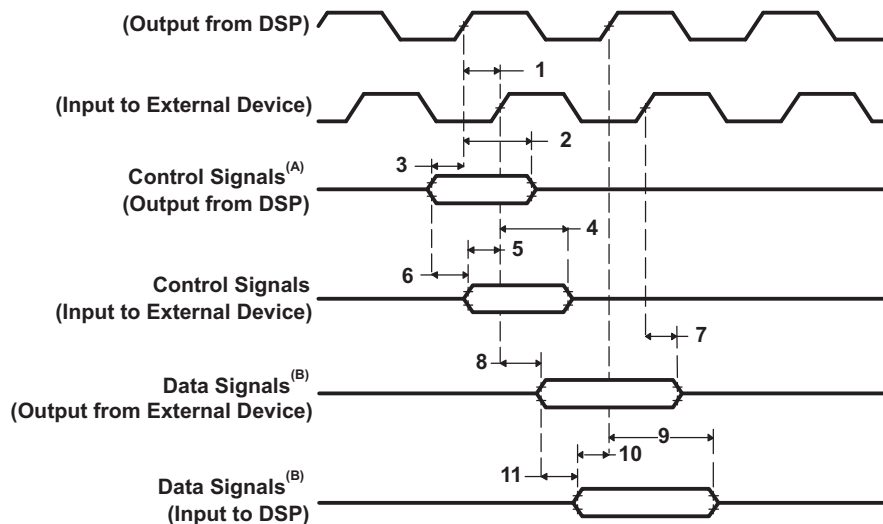

- A. Control signals include data for writes.
- B. Data signals are generated during reads from an external device.

Figure 6-4. Board-Level Input/Output Timings

6.2 Recommended Clock and Control Signal Transition Behavior

All clocks and control signals **must** transition between V_{IH} and V_{IL} (or between V_{IL} and V_{IH}) in a monotonic manner.

6.3 Power Supplies

For more information regarding TI's power management products and suggested devices to power TI DSPs, visit www.ti.com/dsppower.

6.3.1 Power-Supply Sequencing

The device includes 1.2-V core supply (CV_{DD} , CV_{DDESS} , CV_{DD1} , AV_{DDA} , DV_{DDD} , AV_{DDT}), and two I/O supplies—3.3-V (DV_{DD33}) and 1.8-V (DV_{DD18} , AV_{DLL1} , AV_{DLL2} , AV_{DDR}). To ensure proper device operation, a specific power-up sequence must be followed. Some TI power-supply devices include features that facilitate power sequencing — for example, Auto-Track and Slow-Start/Enable features. For more information on TI power supplies and their features, visit www.ti.com/dsppower.

Following is a summary of the power sequencing requirements:

- The power ramp order must be 3.3-V (DV_{DD33}) before 1.8-V (DV_{DD18} , AV_{DLL1} , AV_{DLL2} , AV_{DDR}), and 1.8-V (DV_{DD18} , AV_{DLL1} , AV_{DLL2} , AV_{DDR}) before 1.2-V core supply (CV_{DD} , CV_{DDESS} , CV_{DD1} , AV_{DDA} , DV_{DDD} , AV_{DDT}) —meaning during power up, the voltage at the 1.8-V rail should never exceed the voltage at the 3.3-V rail. Similarly, the voltage at the 1.2-V rail should never exceed the voltage at the DV_{DDR2} rail.
- From the time that power ramp begins, all power supplies (3.3 V, 1.8 V, 1.2 V) must be stable within 200 ms. The term "stable" means reaching the recommended operating condition (see [Section 5.2](#)).

6.3.2 Power-Supply Design Considerations

Core and I/O supply voltage regulators should be located close to the DSP to minimize inductance and resistance in the power delivery path. Additionally, when designing for high-performance applications utilizing the device, the PC board should include separate power planes for core, I/O, and ground; all bypassed with high-quality low-ESL/ESR capacitors.

6.3.3 Power-Supply Decoupling

In order to properly decouple the supply planes from system noise, place as many capacitors (caps) as possible close to the DSP. These caps need to be close to the DSP, no more than 1.25 cm maximum distance to be effective. Physically smaller caps are better, such as 0402, but need to be evaluated from a yield/manufacturing point-of-view. Parasitic inductance limits the effectiveness of the decoupling capacitors; therefore physically smaller capacitors should be used while maintaining the largest available capacitance value. Larger caps for each supply can be placed further away for bulk decoupling. Large bulk caps (on the order of 100 μ F) should be furthest away, but still as close as possible. Large caps for each supply should be placed outside of the BGA footprint.

6.3.4 Power and Sleep Controller (PSC)

The power and sleep controller (PSC) controls power by turning off unused power domains or by gating off clocks to individual peripherals/modules. The device uses the clock-gating feature of the PSC only for power savings. The PSC consists of a global PSC (GPSC) and a set of local PSCs (LPSCs).

The GPSC contains memory mapped registers, PSC interrupt control, and a state machine for each peripheral/module. An LPSC is associated with each peripheral/module and provides clock and reset control. The LPSCs are shown in [Table 6-2](#). The PSC register memory map is given in [Table 6-3](#). For more details on the PSC, see the *TMS320DM647/TMS320DM648 DSP Subsystem Reference Guide* (literature number [SPRUEU6](#)).

Table 6-2. LPSC Assignments

LPSC NUMBER	PERIPHERAL/ MODULE
0	EDMA3CC
1	Reserved
2	Reserved
3	Reserved
4	Reserved
5	Reserved
6	Reserved
7	DDR2 Memory Controller
8	UHPI
9	VLYNQ
10	GPIO
11	TIMER0
12	TIMER1
13	Reserved
14	Reserved
15	Reserved
16	Reserved
17	SPI
18	I2C
19	PCI
20	VP0
21	VP1
22	VP2
23	VP3
24	VP4
25	EMIFA
26	TIMER2
27	TIMER3
28	VIC
29	McASP
30	UART
31	VICP
32	Reserved
33	C64x+ CPU
34	Ethernet Subsystem

Table 6-3. PSC Register Memory Map

HEX ADDRESS RANGE	REGISTER ACRONYM	DESCRIPTION
0x0204 6000	PID	Peripheral Revision and Class Information Register
0x0204 6004- 0x0204 600F	–	Reserved
0x0204 6010	–	Reserved
0x0204 6014		Reserved
0x0204 6018	INTEVAL	Interrupt Evaluation Register
0x0204 601C- 0x0204 603F	–	Reserved
0x0204 6040	–	Reserved
0x0204 6044	MERRPR1	Module Error Pending 1 (mod 32- 63) Register
0x0204 6048- 0x0204 604F	–	Reserved

Table 6-3. PSC Register Memory Map (continued)

HEX ADDRESS RANGE	REGISTER ACRONYM	DESCRIPTION
0x0204 6050	–	Reserved
0x0204 6054	MERRCR1	Module Error Clear 1 (mod 32 - 63) Register
0x0204 6058- 0x0204 605F	–	Reserved
0x0204 6060	–	Reserved
0x0204 6064- 0x0204 6067	–	Reserved
0x0204 6068	–	Reserved
0x0204 606C- 0x0204 611F	–	Reserved
0x0204 6120	PTCMD	Power Domain Transition Command Register
0x0204 6124- 0x0204 6127	–	Reserved
0x0204 6128	PTSTAT	Power Domain Transition Status Register
0x0204 612C- 0x0204 61FF	–	Reserved
0x0204 6200	PDSTAT0	Power Domain Status 0 Register (Always On)
0x0204 6204- 0x0204 62FF	–	Reserved
0x0204 6300	PDCTL0	Power Domain Control 0 Register (Always On)
0x0204 6304- 0x1C4 150F	–	Reserved
0x0204 6510	–	Reserved
0x0204 6514	–	Reserved
0x0204 6518- 0x0204 65FF	–	Reserved
0x0204 6600- 0x0204 67FF	–	Reserved
0x0204 6800	MDSTAT0	Module Status 0 Register (EDMACC)
0x0204 6804	–	Reserved
0x0204 6808	–	Reserved
0x0204 680C	–	Reserved
0x0204 6810	–	Reserved
0x0204 6814	–	Reserved
0x0204 6818	–	Reserved
0x0204 681C	MDSTAT7	Module Status 7 Register (DDR2)
0x0204 6820	MDSTAT8	Module Status 8 Register (HPI)
0x0204 6824	MDSTAT9	Module Status 9 Register (VLYNQ)
0x0204 6828	MDSTAT10	Module Status 10 Register (GPIO)
0x0204 682C	MDSTAT11	Module Status 11 Register (TIMER 0)
0x0204 6830	MDSTAT12	Module Status 12 Register (TIMER 1)
0x0204 6834	–	Reserved
0x0204 6838	–	Reserved
0x0204 683C	–	Reserved
0x0204 6840	–	Reserved
0x0204 6844	MDSTAT17	Module Status 17 Register (SPI)
0x0204 6848	MDSTAT18	Module Status 18 Register (I2C)
0x0204 684C	MDSTAT19	Module Status 19 Register (PCI)
0x0204 6850	MDSTAT20	Module Status 20 Register (Video Port 0)
0x0204 6854	MDSTAT21	Module Status 21 Register (Video Port 1)
0x0204 6858	MDSTAT22	Module Status 22 Register (Video Port 2)
0x0204 685C	MDSTAT23	Module Status 23 Register (Video Port 3)
0x0204 6860	MDSTAT24	Module Status 24 Register (Video Port 4)
0x0204 6864	MDSTAT25	Module Status 25 Register (EMIFA)
0x0204 6868	MDSTAT26	Module Status 26 Register (TIMER 2)
0x0204 686C	MDSTAT27	Module Status 27 Register (TIMER 3)

Table 6-3. PSC Register Memory Map (continued)

HEX ADDRESS RANGE	REGISTER ACRONYM	DESCRIPTION
0x0204 6870	MDSTAT28	Module Status 28 Register (VIC)
0x0204 6874	MDSTAT29	Module Status 29 Register (McASP)
0x0204 6878	MDSTAT30	Module Status 30 Register (UART)
0x0204 687C	MDSTAT31	Module Status 31 Register (VICP)
0x0204 6880	–	Reserved
0x0204 6884	MDSTAT33	Module Status 33 Register (C64x+ CPU)
0x0204 6888	MDSTAT34	Module Status 34 Register (Ethernet Subsystem)
0x0204 688C-0x0204 69FF	–	Reserved
0x0204 6A00	MDCTL0	Module Control 0 Register (EDMACC)
0x0204 6A04	–	Reserved
0x0204 6A08	–	Reserved
0x0204 6A0C	–	Reserved
0x0204 6A10	–	Reserved
0x0204 6A14	–	Reserved
0x0204 6A18	–	Reserved
0x0204 6A1C	MDCTL7	Module Control 7 Register (DDR2)
0x0204 6A20	MDCTL8	Module Control 8 Register (HPI)
0x0204 6A24	MDCTL9	Module Control 9 Register (VLYNQ)
0x0204 6A28	MDCTL10	Module Control 10 Register (GPIO)
0x0204 6A2C	MDCTL11	Module Control 11 Register (TIMER 0)
0x0204 6A30	MDCTL12	Module Control 12 Register (TIMER 1)
0x0204 6A34	–	Reserved
0x0204 6A38	–	Reserved
0x0204 6A3C	–	Reserved
0x0204 6A40	–	Reserved
0x0204 6A44	MDCTL17	Module Control 17 Register (SPI)
0x0204 6A48	MDCTL18	Module Control 18 Register (I2C)
0x0204 6A4C	MDCTL19	Module Control 19 Register (PCI)
0x0204 6A50	MDCTL20	Module Control 20 Register (Video Port 0)
0x0204 6A54	MDCTL21	Module Control 21 Register (Video Port 1)
0x0204 6A58	MDCTL22	Module Control 22 Register (Video Port 2)
0x0204 6A5C	MDCTL23	Module Control 23 Register (Video Port 3)
0x0204 6A60	MDCTL24	Module Control 24 Register (Video Port 4)
0x0204 6A64	MDCTL25	Module Control 25 Register (EMIFA)
0x0204 6A68	MDCTL26	Module Control 26 Register (TIMER 2)
0x0204 6A6C	MDCTL27	Module Control 27 Register (TIMER 3)
0x0204 6A70	MDCTL28	Module Control 28 Register (VIC)
0x0204 6A74	MDCTL29	Module Control 29 Register (McASP)
0x0204 6A78	MDCTL30	Module Control 30 Register (UART)
0x0204 6A7C	MDCTL31	Module Control 31 Register (VICP)
0x0204 6A80	–	Reserved
0x0204 6A84	MDCTL33	Module Control 33 Register (C64x+ CPU)
0x0204 6A88	MDCTL34	Module Control 34 Register (Ethernet Subsystem)
0x0204 6A90- 0x0204 6FFF	–	Reserved

6.3.5 Power and Clock Domains

The device includes two power domains: the System Domain and the Ethernet Subsystem Domain. Both of these power domains are always on when the chip is on. Both of these domains are powered by the CV_{DD} pins of the device.

The primary PLL controller generates the input clock to the C64x+ megamodule as well as most of the system peripherals such as the multichannel audio serial ports (McASPs) and the external memory interface (EMIFA). The secondary PLL controller generates interface clocks for the DDR2 memory controller. The Ethernet Subsystem is clocked through the SerDes module, which takes input from REFCLKP/N. The primary PLL controller (PLL1 controller) uses the device input clock CLKIN1 and the secondary PLL controller (PLL2 controller) uses the device input clock CLKIN2.

Table 6-4 provides a listing of the clock domains.

Table 6-4. Power and Clock Domains

POWER DOMAIN	CLOCK DOMAIN	PERIPHERAL/MODULE/USAGE
System Domain	CLKDIV1	C64x+ CPU
System Domain	CLKDIV3	EDMA/SCR
System Domain	CLKDIV3	DDR Subsystem
System Domain	CLKDIV3	Video Port 0
System Domain	CLKDIV3	Video Port 1
System Domain	CLKDIV3	Video Port 2
System Domain	CLKDIV3	Video Port 3
System Domain	CLKDIV3	Video Port 4
System Domain	CLKDIV3	EMIFA
System Domain	CLKDIV6	HPI
System Domain	CLKDIV6	PCI
System Domain	CLKDIV6	VLYNQ
System Domain	CLKDIV6	UART
System Domain	CLKDIV6	I2C
System Domain	CLKDIV6	TIMER 0
System Domain	CLKDIV6	TIMER 1
System Domain	CLKDIV6	TIMER 2
System Domain	CLKDIV6	TIMER 3
System Domain	CLKDIV6	SPI
System Domain	CLKDIV6	McASP
System Domain	CLKDIV6	VIC
System Domain	CLKDIV6	GPIO
System Domain	CLKDIV6	PLL Controller 1
System Domain	CLKDIV6	PLL Controller 2
System Domain	CLKDIV6	Config SCR
System Domain	CLKDIV4 0	Internal EMIFA Clock
System Domain	CLKDIV4 1	Emulation and Trace
System Domain	CLKDIV4 2	VICP cop_clk/2
System Domain	CLKDIV2	VICP cop_clk
Ethernet Subsystem Domain	SerDes TXBCLK	Ethernet Subsystem

The device architecture is divided into the power and clock domains shown in [Table 6-5](#), which further shows the clock domains and their ratios.

Table 6-5. Clock Domain Assignment

SUBSYSTEM	CLOCK DOMAIN	DOMAIN CLOCK SOURCE	FIXED RATIO vs SYSREFCLK FREQUENCY
DSP Subsystem	CLKDIV1	PLL1.REFSYSCLK	-
Peripherals (CLKDIV3 Domain)	CLKDIV3	PLL1.SYSCLK1	1:3
Emulation/Trace	CLKDIV4 1	PLL1.SYSCLK2	1:4
Peripherals (CLKDIV6 Domain)	CLKDIV6	PLL1.SYSCLK3	1:6
Internal EMIFA Clock	CLKDIV4 0	PLL1.SYSCLK4	1:4 ⁽¹⁾
VICP cop_clk/2	CLKDIV4 2	PLL1.SYSCLK5	1:4
VICP cop_clk	CLKDIV2	PLL1.SYSCLK6	1:2

(1) There is a /2 divider in the path of PLL1.SYSCLK4 so the effective EMIFA clock is PLL1.SYSCLK4/2. By default the internal EMIFA Clock is 1:8.

6.3.6 Preserving Boundary-Scan Functionality on DDR2 Memory Pins

Similarly, when the DDR2 Memory Controller is not used, the DDR_VREF, RSV19, and RSV20 pins can be connected directly to ground (V_{SS}) to save power. However, this will prevent boundary-scan from functioning on the DDR2 Memory Controller pins. To preserve boundary-scan functionality on the DDR2 Memory Controller pins, DDR_VREF, RSV19, and RSV20 should be connected as follows:

- DDR_VREF - connect to a voltage of $DV_{DD18}/2$. The $DV_{DD18}/2$ voltage can be generated directly from the DV_{DD18} supply using two 1-k Ω resistors to form a resistor divider circuit.
- RSV19 - connect this pin to the 1.8-V I/O supply (DV_{DD18}) via a 200- Ω resistor
- RSV20 - connect this pin to ground (V_{SS}) via a 200- Ω resistor.

6.4 PLL1 Controller

The primary PLL controller generates the input clock to the C64x+ megamodule (including the CPU) as well as most of the system peripherals such as the multichannel audio serial ports (McASPs) and the external memory interface (EMIFA). Figure 6-5 shows a functional block diagram of the PLL Input Clock.

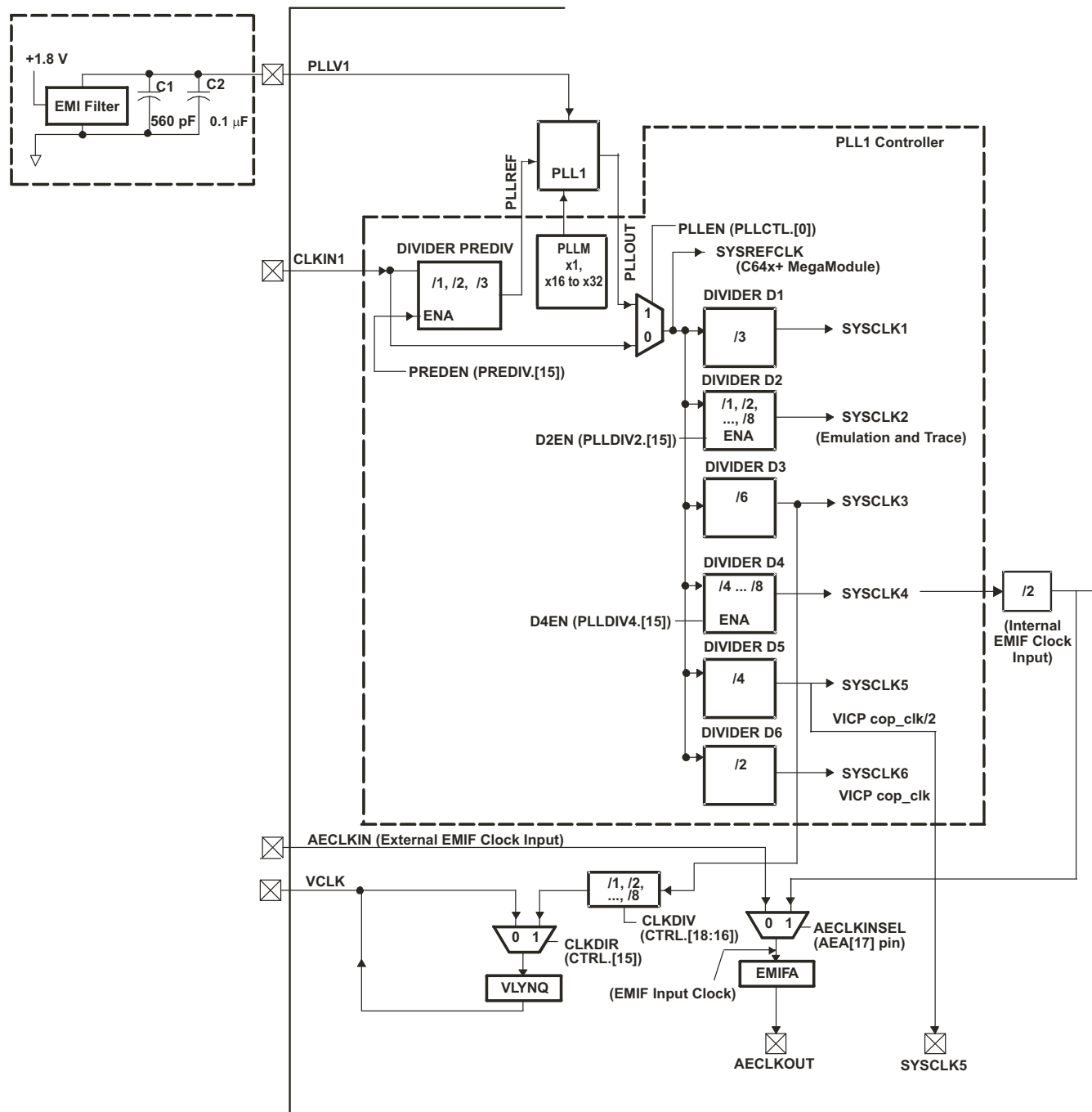

Figure 6-5. PLL Input Clock

As shown in [Figure 6-5](#), the PLL1 controller features a software-programmable PLL multiplier controller (PLLM) and seven dividers (PREDIV, D1, D2, D3, D4, D5). The PLL1 controller uses the device input clock CLKIN1 to generate a system reference clock (SYSREFCLK) and system clocks (SYSCLK1, SYSCLK2, SYSCLK3, SYSCLK4, SYSCLK5). PLL1 power is supplied externally via the PLL1 power-supply pin (PLL1V1). An external EMI filter circuit must be added to PLL1V1. The 1.8-V supply of the EMI filter must be from the same 1.8-V power plane supplying the I/O power-supply pin, DV_{DD18}. TI requires EMI filter manufacturer Murata, part number NFM18CC222R1C3.

All PLL external components (C1, C2, and the EMI Filter) must be placed as close to the C64x+ DSP device as possible. For the best performance, TI recommends that all the PLL external components be on a single side of the board without jumpers, switches, or components other than the ones shown. For reduced PLL jitter, maximize the spacing between switching signals and the PLL external components (C1, C2, and the EMI Filter). The minimum CLKIN1 rise and fall times should also be observed. For the input clock timing requirements, see [Section 6.4.4](#).

6.4.1 PLL1 Controller Device-Specific Information

As shown in [Figure 6-5](#), the PLL1 controller generates several internal clocks including the system reference clock (SYSREFCLK), and the system clocks (SYSCLK1/2/3/4/5/6). The high-frequency clock signal SYSREFCLK is directly used to clock the C64x+ megamodule (including the CPU) and also serves as a reference clock for the rest of the DSP system. Dividers D1, D2, D3, D4, D5, and D6 divide the high-frequency clock SYSREFCLK to generate SYSCLK1, SYSCLK2, SYSCLK3, SYSCLK4, SYSCLK5, and SYSCLK6, respectively.

The system clocks are used to clock different portions of the DSP as follows:

- SYSCLK1 is used for the following modules: 3PDMA, the SCR and the bridges, DDR Subsystem internal logic, Video Port 0, Video Port 1, Video Port 2, Video Port 3, Video Port 4, EMIFA internal logic.
- SYSCLK2 is used for Emulation and Trace
- SYSCLK3 is used for most of the peripherals. These modules are clocked from SYSCLK3: HPI, PCI, VLYNQ, UART, I2C, TIMER 0, TIMER 1, TIMER 2, TIMER 3, SPI, McASP, VIC, GPIO, PLL Controller 1, PLL Controller 2, Config SCR
- SYSCLK4 is used as the EMIFA AECLKOUT
[When SYSCLK4 is used as the EMIF input clock source, the actual clock goes through a divider and the frequency would be SYSCLK4 divide-by-2 (see [Figure 6-5, PLL Input Clock](#)).]
- SYSCLK5 is used as the VICP internal clock
- SYSCLK6 is used as the VICP internal clock

The PLL multiplier controller (PLLM) must be programmed after reset. There is no hardware CLKMODE selection on the device. Since the divider ratio bits for dividers D1, D3, D5, and D6 are fixed, the frequency of SYSCLK1, SYCLK3, SYSCLK5, and SYSCLK6 is tied to the frequency of SYSREFCLK. However, the frequency of SYSCLK2 and SYSCLK4 depends on the configuration of dividers D2 and D4. For example, with PLLM in the PLL1 multiply control register set to 10011b (x20 mode) and a 35-MHz CLKIN1 input, the PLL output PLLOUT is set to 700 MHz and SYSCLK1 and SYSCLK3 run at 233 MHz and 117 MHz, respectively. Divider D4 can be programmed through the PLLDIV4 register to divide SYSREFCLK by 8 ($2 * (PLLDIV4.RATIO+1)$) such that SYSCLK4 runs at 87.5 MHz.

Note that there is a minimum and maximum operating frequency for PLLREF, PLLOUT, and SYSCLK4. The PLL1 Controller must not be configured to exceed any of these constraints (certain combinations of external clock input, internal dividers, and PLL multiply ratios might not be supported). For the PLL clocks input and output frequency ranges, see [Table 6-6](#).

Table 6-6. PLL1 Clock Frequency Ranges

CLOCK SIGNAL	MIN	MAX	UNIT
CLKIN1	25	66.6	MHz
PLLREF (PLEN = 1) ⁽¹⁾	25	66.6	MHz
PLLOUT ⁽¹⁾	400	720 (-720 devices)	MHz
	400	800 (-800 devices) ⁽²⁾	MHz
	400	900 (-900 devices)	MHz
	400	1100 (-1100 devices)	MHz
SYSCLK4	1/16P ⁽³⁾	PLLOUT / (2*(PLLDIV4.RATIO+1)) ⁽⁴⁾	MHz

(1) Only applies when the PLL1 Controller is set to PLL mode (PLEN = 1 in the PLLCTL register). Based on CLKIN1 and PLLOUT, PLL1 multiplier factor ranges from x16 to x32.

(2) Only for Extended Temperature Range device (-800 MHz)

(3) P = 1/CPU clock frequency in ns

(4) PLLDIV4.RATIO = 3

6.4.2 PLL1 Controller Operating Modes

The PLL1 controller has two modes of operation: bypass mode and PLL mode. The mode of operation is determined by the PLEN bit of the PLL control register (PLLCTL). In PLL mode, SYSREFCLK is generated from the device input clock CLKIN1 using the divider PREDIV and the PLL multiplier PLLM. In bypass mode, CLKIN1 is fed directly to SYSREFCLK.

All hosts (i.e., HPI) must hold off accesses to the DSP while the frequency of its internal clocks is changing. A mechanism must be in place such that the DSP notifies the host when the PLL configuration has completed.

6.4.3 PLL1 Stabilization, Lock, and Reset Times

The PLL stabilization time is the amount of time that must be allotted for the internal PLL regulators to become stable after device power-up. The PLL should not be operated until this stabilization time has finished.

The PLL reset time is the amount of wait time needed when resetting the PLL (writing PLLRST = 1) for the PLL to properly reset, before bringing the PLL out of reset (writing PLLRST = 0). For the PLL1 reset time value, see [Table 6-7](#).

Table 6-7. PLL1 Stabilization, Lock, and Reset Times

	MIN	TYP	MAX	UNIT
PLL stabilization time	150			μs
PLL lock time			2000 × C ⁽¹⁾	μs
PLL reset time	128 × C ⁽¹⁾			μs

(1) C = CLKIN1 cycle time in ns. For example, when CLKIN1 frequency is 50 MHz, use C = 20 ns.

6.4.4 PLL1 Controller Input and Output Clock Electrical Data/Timing

Table 6-8. Timing Requirements for CLKIN1⁽¹⁾⁽²⁾ (see Figure 6-6)

NO.			720, 800, 900, 1100		UNIT
			PLL MODES ⁽³⁾		
			MIN	MAX	
1	$t_{c(CLKIN1)}$	Cycle time, CLKIN1	15	40	ns
2	$t_{w(CLKIN1H)}$	Pulse duration, CLKIN1 high	0.4C		ns
3	$t_{w(CLKIN1L)}$	Pulse duration, CLKIN1 low	0.4C		ns
4	$t_t(CLKIN1)$	Transition time, CLKIN1		1.2	ns
5	$t_j(CLKIN1)$	Period jitter, (peak-to-peak), CLKIN1		100	ps

- (1) The reference points for the rise and fall transitions are measured at 3.3-V V_{IL} MAX and V_{IH} MIN.
- (2) C = CLKIN1 cycle time in ns. For example, when CLKIN1 frequency is 50 MHz, use C = 20 ns.
- (3) The PLL1 multiplier factors (x1 [BYPASS], x16 to x32) further limit the MIN and MAX values for $t_{c(CLKIN1)}$. See Section 6.3.5 for supported PLL1 multiplier factors.

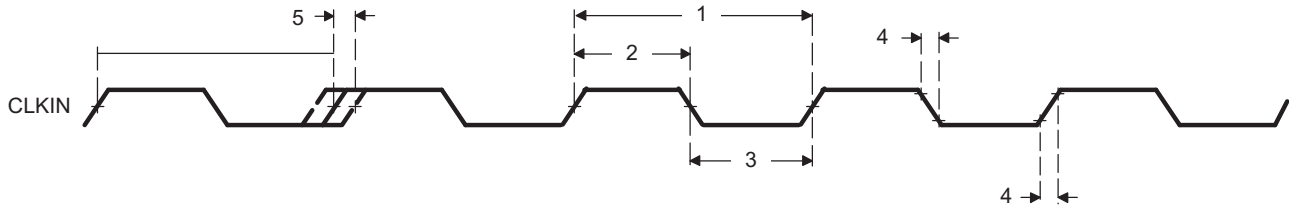

Figure 6-6. CLKIN1 Timing

6.4.5 PLL1 Controller Register Description(s)

A summary of the PLL1 controller registers is shown in Table 6-9.

Table 6-9. PLL1 and Reset Controller Registers Memory Map

HEX ADDRESS RANGE	REGISTER NAME	DESCRIPTION
0x020E 0000	PID	Peripheral Identification and Revision Information Register
0x020E 00E4	RSTYPE	Reset Type Register
0x020E 0100	PLLCTL	PLL Controller 1 Operations Control Register
0x020E 0110	PLLM	PLL Controller 1 Multiplier Control Register
0x020E 0114	PREDIV	PLL Pre-Divider Control Register
0x020E 011C	PLLDIV2	PLL Controller 1 Control-Divider 2 Register (SYSCLK2)
0x020E 0138	PLLCMD	PLL Controller 1 Command Register
0x020E 013C	PLLSTAT	PLL Controller 1 Status Register (Shows PLLC1 Status)
0x020E 0140	ALNCTL	PLL Controller Clock Align Control Register
0x020E 0144	DCHANGE	PLLDIV Ratio Change Status Register
0x020E 0150	SYSTAT	PLL Controller 1 System Clock Status 1 Register (Indicates SYSCLK on/off Status)
0x020E 0160	PLLDIV4	PLL Controller 1 Control-Divider 4 Register (SYSCLK4)

6.5 PLL2 Controller

The secondary PLL controller generates interface clocks for the DDR2 memory controller.

As shown in [Figure 6-7](#), the PLL2 controller features a PLL multiplier controller. The PLL multiplier is fixed to a x20 multiplier rate. PLL2 power is supplied externally via the PLL2 power supply (PLL2V2). An external PLL filter circuit must be added to PLL2V2 as shown in [Figure 6-7](#). The 1.8-V supply for the EMI filter must be from the same 1.8-V power plane supplying the I/O power-supply pin, DV_{DD18}. TI requires EMI filter manufacturer Murata, part number NFM18CC222R1C3.

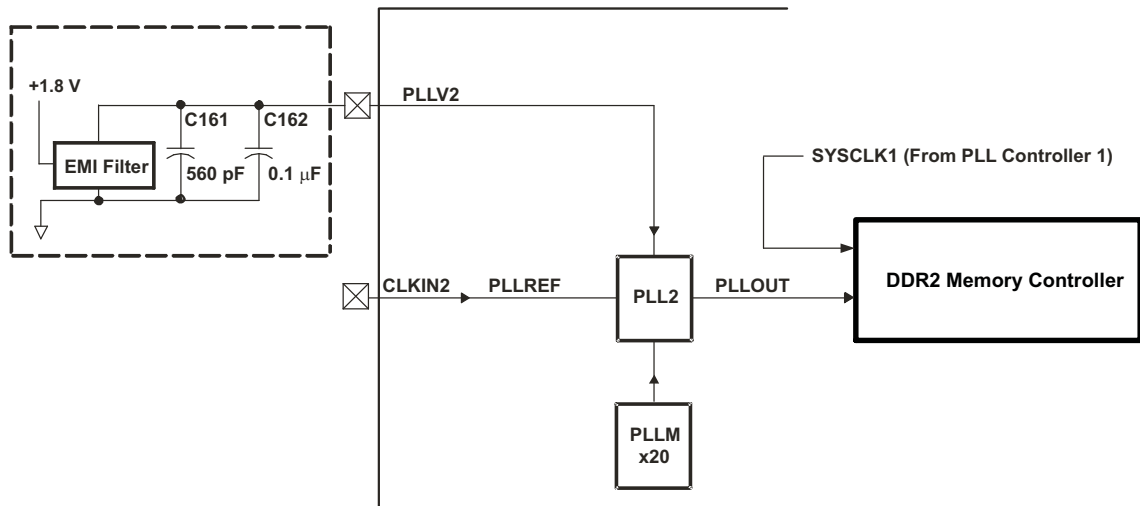

Figure 6-7. PLL Controller

All PLL external components (C161, C162, and the EMI Filter) should be placed as close to the C64x+ DSP device as possible. For the best performance, TI requires that all the PLL external components be on a single side of the board without jumpers, switches, or components other than the ones shown. For reduced PLL jitter, maximize the spacing between switching signals and the PLL external components (C161, C162, and the EMI Filter). The minimum CLKIN2 rise and fall times should also be observed. For the input clock timing requirements, see [Section 6.5.3](#), PLL2 Controller Input Clock Electrical Data/Timing.

6.5.1 PLL2 Controller Device-Specific Information

As shown in [Figure 6-7](#), the output of PLL2, PLLOUT, is directly fed to the DDR2 memory controller. This clock is used by the DDR2 memory controller to generate DDR2CLKOUT and DDR2CLKOUTz. Note that, internally, the data bus interface of the DDR2 memory controller is clocked by SYSCLK1 of the PLL1 controller.

Note that there is a minimum and maximum operating frequency for PLLREF and PLLOUT. The clock generator must not be configured to exceed any of these constraints. For the PLL clocks input and output frequency ranges, see [Table 6-10](#).

Table 6-10. PLL2 Clock Frequency Ranges

CLOCK SIGNAL	REQUIRED FREQUENCY	UNIT
PLLREF (CLKIN2)	20 - 26.6	MHz
PLLOUT (DDR2 clock)	400 - 533 ⁽¹⁾	MHz

(1) This clock is the 2x of the DDR clock. The DDR PHY divides the clock down /2.

6.5.2 PLL2 Controller Operating Modes

Unlike the PLL1 controller that can operate in bypass and a PLL mode, the PLL2 controller only operates in PLL mode. PLL2 is unlocked only during the power-up sequence (see Section 6.7) and is locked by the time the $\overline{\text{RESETSTAT}}$ pin goes high. It does not lose lock during any of the other resets.

6.5.3 PLL2 Controller Input Clock Electrical Data/Timing

Table 6-11. Timing Requirements for CLKIN2^{(1) (2)} (see Figure 6-8)

NO.			720, 800, 900, 1100		UNIT
			PLL MODE x20		
			MIN	MAX	
1	$t_{c(\text{CLKIN2})}$	Cycle time, CLKIN2	37.5	50	ns
2	$t_{w(\text{CLKIN2H})}$	Pulse duration, CLKIN2 high	0.4C		ns
3	$t_{w(\text{CLKIN2L})}$	Pulse duration, CLKIN2 low	0.4C		ns
4	$t_{t(\text{CLKIN2})}$	Transition time, CLKIN2		1.2	ns
5	$t_{j(\text{CLKIN2})}$	Period jitter, (peak-to-peak) CLKIN2		100	ps

- (1) The reference points for the rise and fall transitions are measured at 3.3-V V_{IL} MAX and V_{IH} MIN.
 (2) C = CLKIN2 cycle time in ns. For example, when CLKIN2 frequency is 25 MHz, use C = 40 ns.

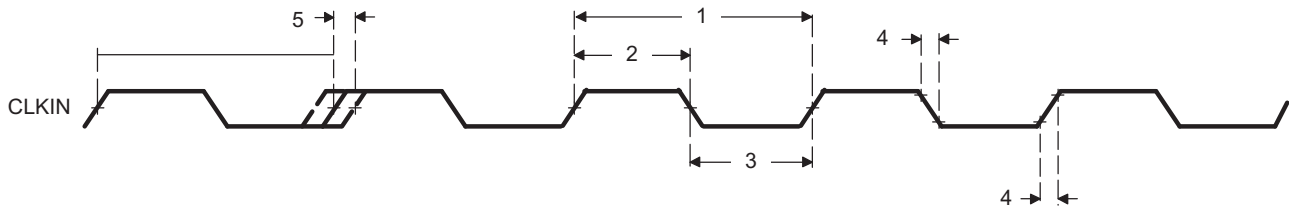

Figure 6-8. CLKIN2 Timing

6.5.4 PLL2 Controller Register Description(s)

A summary of the PLL2 controller registers is shown in Table 6-12.

Table 6-12. PLL2 and Reset Controller Registers Memory Map

HEX ADDRESS RANGE	REGISTER NAME	DESCRIPTION
0x0212 0000	PID	Peripheral Identification and Revision Information Register
0x0212 0100	PLLCTL	PLL Controller 2 Operations Control Register
0x0212 0110	PLLM	PLL Controller 2 Multiplier Control Register
0x0212 0138	PLLCMD	PLL Controller 2 Command Register
0x0212 013C	PLLSTAT	PLL Controller 2 Status Register (Shows PLLC1 Status)

6.6 Enhanced Direct Memory Access (EDMA3) Controller

The EDMA controller handles all data transfers between memories and the device slave peripherals on the device. These data transfers include cache servicing, non-cacheable memory accesses, user-programmed data transfers, and host accesses. These are summarized as follows:

- Transfer to/from on-chip memories
 - DSP L1D memory
 - DSP L2 memory
- Transfer to/from external storage
 - DDR2 SDRAM
 - Synchronous/Asynchronous EMIF (EMIFA)
- Transfer to/from peripherals/hosts
 - VLYNQ
 - HPI
 - McASP
 - UART
 - Video Port 0/1/2/3/4
 - Timer 0/1/2/3
 - SPI
 - I2C

6.6.1 EDMA3 Channel Synchronization Events

The EDMA supports up to 64 EDMA channels that service peripheral devices and external memory. [Table 6-13](#) lists the source of EDMA synchronization events associated with each of the programmable EDMA channels. The association of an event to a channel is fixed; each of the EDMA channels has one specific event associated with it. These specific events are captured in the EDMA event registers (ER, ERH) even if the events are disabled by the EDMA event enable registers (EER, EERH). For more detailed information on the EDMA module and how EDMA events are enabled, captured, processed, linked, chained, and cleared, etc., see the *TMS320DM647/DM648 DSP Enhanced DMA (EDMA) Controller User's Guide* (literature number [SPRU2L2](#)).

Table 6-13. EDMA Channel Synchronization Events

TPCC CHANNEL	DEFAULT EVENT#	BINARY	DEFAULT EVENT	TPCC CHANNEL	DEFAULT EVENT #	BINARY	DEFAULT EVENT
0	0	000 0000	HPI/PCI : DSPINT	32	32	010 0000	VP2EVTYA
1	1	000 0001	TIMER0 : TINT0L	33	33	010 0001	VP2EVTcBA
2	2	000 0010	TIMER0 : TINT0H	34	34	010 0010	VP2EVTcRA
3	3	000 0011	TIMER2 : TINT2L	35	35	010 0011	VP2EVTYB
4	4	000 0100	TIMER2 : TINT2H	36	36	010 0100	VP2EVTcBB
5	5	000 0101	TIMER3 : TINT3L	37	37	010 0101	VP2EVTcRB
6	6	000 0110	TIMER3 : TINT3H	38	38	010 0110	VP3EVTYA
7	7	000 0111	VICP: IMXINT	39	39	010 0111	VP3EVTcBA
8	8	000 1000	VICP: VLCDINT	40	40	010 1000	VP3EVTcRA
9	9	000 1001	VICP: DSQINT	41	41	010 1001	VP3EVTYB
10	10	000 1010	McASP: AXEVTE	42	42	010 1010	VP3EVTcBB
11	11	000 1011	McASP: AXEVTO	43	43	010 1011	VP3EVTcRB
12	12	000 1100	McASP: AXEVT	44	44	010 1100	ICREVT
13	13	000 1101	McASP: AREVTE	45	45	010 1101	ICXEVT
14	14	000 1110	McASP: AREVTO	46	46	010 1110	SPI: SPIXEVT
15	15	000 1111	McASP: AREVT	47	47	010 1111	SPI: SPIREVT

Table 6-13. EDMA Channel Synchronization Events (continued)

TPCC CHANNEL	DEFAULT EVENT#	BINARY	DEFAULT EVENT	TPCC CHANNEL	DEFAULT EVENT #	BINARY	DEFAULT EVENT
16	16	001 0000	TIMER1 : TINT1L	48	48	011 0000	VP4EVTYA
17	17	001 0001	TIMER1 : TINT1H	49	49	011 0001	VP4EVTcBA
18	18	001 0010	UART: URXEVT	50	50	011 0010	VP4EVTcRA
19	19	001 0011	UART: UTXEVT	51	51	011 0011	VP4EVTYB
20	20	001 0100	VP0EVTYA	52	52	011 0100	VP4EVTcBB
21	21	001 0101	VP0EVTcBA	53	53	011 0101	VP4EVTcRB
22	22	001 0110	VP0EVTcRA	54	54	011 0110	GPIO : GPINT6
23	23	001 0111	VP0EVTYB	55	55	011 0111	GPIO : GPINT7
24	24	001 1000	VP0EVTcBB	56	56	011 1000	GPIO : GPINT8
25	25	001 1001	VP0EVTcRB	57	57	011 1001	GPIO : GPINT9
26	26	001 1010	VP1EVTYA	58	58	011 1010	GPIO : GPINT10
27	27	001 1011	VP1EVTcBA	59	59	011 1011	GPIO : GPINT11
28	28	001 1100	VP1EVTcRA	60	60	011 1100	GPIO : GPINT12
29	29	001 1101	VP1EVTYB	61	61	011 1101	GPIO : GPINT13
30	30	001 1110	VP1EVTcBB	62	62	011 1110	GPIO : GPINT14
31	31	001 1111	VP1EVTcRB	63	63	011 1111	GPIO : GPINT15

6.6.2 EDMA Peripheral Register Description(s)

Table 6-14 lists the EDMA registers, their corresponding acronyms, and device memory locations.

Table 6-14. EDMA Channel Controller Registers

HEX ADDRESS	ACRONYM	REGISTER NAME
0x02A0 0000	PID	Peripheral ID Register
0x02A0 0004	CCCFG	EDMA3CC Configuration Register
0x02A0 0008 - 0x02A0 00FC		Reserved
0x02A0 0100	DCHMAP0	DMA Channel 0 Mapping Register
0x02A0 0104	DCHMAP1	DMA Channel 1 Mapping Register
0x02A0 0108	DCHMAP2	DMA Channel 2 Mapping Register
0x02A0 010C	DCHMAP3	DMA Channel 3 Mapping Register
0x02A0 0110	DCHMAP4	DMA Channel 4 Mapping Register
0x02A0 0114	DCHMAP5	DMA Channel 5 Mapping Register
0x02A0 0118	DCHMAP6	DMA Channel 6 Mapping Register
0x02A0 011C	DCHMAP7	DMA Channel 7 Mapping Register
0x02A0 0120	DCHMAP8	DMA Channel 8 Mapping Register
0x02A0 0124	DCHMAP9	DMA Channel 9 Mapping Register
0x02A0 0128	DCHMAP10	DMA Channel 10 Mapping Register
0x02A0 012C	DCHMAP11	DMA Channel 11 Mapping Register
0x02A0 0130	DCHMAP12	DMA Channel 12 Mapping Register
0x02A0 0134	DCHMAP13	DMA Channel 13 Mapping Register
0x02A0 0138	DCHMAP14	DMA Channel 14 Mapping Register
0x02A0 013C	DCHMAP15	DMA Channel 15 Mapping Register
0x02A0 0140	DCHMAP16	DMA Channel 16 Mapping Register
0x02A0 0144	DCHMAP17	DMA Channel 17 Mapping Register
0x02A0 0148	DCHMAP18	DMA Channel 18 Mapping Register
0x02A0 014C	DCHMAP19	DMA Channel 19 Mapping Register
0x02A0 0150	DCHMAP20	DMA Channel 20 Mapping Register

Table 6-14. EDMA Channel Controller Registers (continued)

HEX ADDRESS	ACRONYM	REGISTER NAME
0x02A0 0154	DCHMAP21	DMA Channel 21 Mapping Register
0x02A0 0158	DCHMAP22	DMA Channel 22 Mapping Register
0x02A0 015C	DCHMAP23	DMA Channel 23 Mapping Register
0x02A0 0160	DCHMAP24	DMA Channel 24 Mapping Register
0x02A0 0164	DCHMAP25	DMA Channel 25 Mapping Register
0x02A0 0168	DCHMAP26	DMA Channel 26 Mapping Register
0x02A0 016C	DCHMAP27	DMA Channel 27 Mapping Register
0x02A0 0170	DCHMAP28	DMA Channel 28 Mapping Register
0x02A0 0174	DCHMAP29	DMA Channel 29 Mapping Register
0x02A0 0178	DCHMAP30	DMA Channel 30 Mapping Register
0x02A0 017C	DCHMAP31	DMA Channel 31 Mapping Register
0x02A0 0180	DCHMAP32	DMA Channel 32 Mapping Register
0x02A0 0184	DCHMAP33	DMA Channel 33 Mapping Register
0x02A0 0188	DCHMAP34	DMA Channel 34 Mapping Register
0x02A0 018C	DCHMAP35	DMA Channel 35 Mapping Register
0x02A0 0190	DCHMAP36	DMA Channel 36 Mapping Register
0x02A0 0194	DCHMAP37	DMA Channel 37 Mapping Register
0x02A0 0198	DCHMAP38	DMA Channel 38 Mapping Register
0x02A0 019C	DCHMAP39	DMA Channel 39 Mapping Register
0x02A0 01A0	DCHMAP40	DMA Channel 40 Mapping Register
0x02A0 01A4	DCHMAP41	DMA Channel 41 Mapping Register
0x02A0 01A8	DCHMAP42	DMA Channel 42 Mapping Register
0x02A0 01AC	DCHMAP43	DMA Channel 43 Mapping Register
0x02A0 01B0	DCHMAP44	DMA Channel 44 Mapping Register
0x02A0 01B4	DCHMAP45	DMA Channel 45 Mapping Register
0x02A0 01B8	DCHMAP46	DMA Channel 46 Mapping Register
0x02A0 01BC	DCHMAP47	DMA Channel 47 Mapping Register
0x02A0 01C0	DCHMAP48	DMA Channel 48 Mapping Register
0x02A0 01C4	DCHMAP49	DMA Channel 49 Mapping Register
0x02A0 01C8	DCHMAP50	DMA Channel 50 Mapping Register
0x02A0 01CC	DCHMAP51	DMA Channel 51 Mapping Register
0x02A0 01D0	DCHMAP52	DMA Channel 52 Mapping Register
0x02A0 01D4	DCHMAP53	DMA Channel 53 Mapping Register
0x02A0 01D8	DCHMAP54	DMA Channel 54 Mapping Register
0x02A0 01DC	DCHMAP55	DMA Channel 55 Mapping Register
0x02A0 01E0	DCHMAP56	DMA Channel 56 Mapping Register
0x02A0 01E4	DCHMAP57	DMA Channel 57 Mapping Register
0x02A0 01E8	DCHMAP58	DMA Channel 58 Mapping Register
0x02A0 01EC	DCHMAP59	DMA Channel 59 Mapping Register
0x02A0 01F0	DCHMAP60	DMA Channel 60 Mapping Register
0x02A0 01F4	DCHMAP61	DMA Channel 61 Mapping Register
0x02A0 01F8	DCHMAP62	DMA Channel 62 Mapping Register
0x02A0 01FC	DCHMAP63	DMA Channel 63 Mapping Register
0x02A0 0200	QCHMAP0	QDMA Channel 0 Mapping to PaRAM Register
0x02A0 0204	QCHMAP1	QDMA Channel 1 Mapping to PaRAM Register
0x02A0 0208	QCHMAP2	QDMA Channel 2 Mapping to PaRAM Register
0x02A0 020C	QCHMAP3	QDMA Channel 3 Mapping to PaRAM Register

Table 6-14. EDMA Channel Controller Registers (continued)

HEX ADDRESS	ACRONYM	REGISTER NAME
0x02A0 0210	QCHMAP4	QDMA Channel 4 Mapping to PaRAM Register
0x02A0 0214	QCHMAP5	QDMA Channel 5 Mapping to PaRAM Register
0x02A0 0218	QCHMAP6	QDMA Channel 6 Mapping to PaRAM Register
0x02A0 021C	QCHMAP7	QDMA Channel 7 Mapping to PaRAM Register
0x02A0 0220 - 0x02A0 021C	-	Reserved
0x02A0 0220 - 0x02A0 023C	-	Reserved
0x02A0 0240	DMAQNUM0	DMA Queue Number Register 0 (Channels 00 to 07)
0x02A0 0244	DMAQNUM1	DMA Queue Number Register 1 (Channels 08 to 15)
0x02A0 0248	DMAQNUM2	DMA Queue Number Register 2 (Channels 16 to 23)
0x02A0 024C	DMAQNUM3	DMA Queue Number Register 3 (Channels 24 to 31)
0x02A0 0250	DMAQNUM4	DMA Queue Number Register 4 (Channels 32 to 39)
0x02A0 0254	DMAQNUM5	DMA Queue Number Register 5 (Channels 40 to 47)
0x02A0 0258	DMAQNUM6	DMA Queue Number Register 6 (Channels 48 to 55)
0x02A0 025C	DMAQNUM7	DMA Queue Number Register 7 (Channels 56 to 63)
0x02A0 0260	QDMAQNUM	CC QDMA Queue Number
0x02A0 0264 - 0x02A0 0280	-	Reserved
0x02A0 0284	QUEPRI	Queue Priority Register
0x02A0 0288 - 0x02A0 02FC	-	Reserved
0x02A0 0300	EMR	Event Missed Register
0x02A0 0304	EMRH	Event Missed Register High
0x02A0 0308	EMCR	Event Missed Clear Register
0x02A0 030C	EMCRH	Event Missed Clear Register High
0x02A0 0310	QEMR	QDMA Event Missed Register
0x02A0 0314	QEMCR	QDMA Event Missed Clear Register
0x02A0 0318	CCERR	EDMA3CC Error Register
0x02A0 031C	CCERRCLR	EDMA3CC Error Clear Register
0x02A0 0320	EEVAL	Error Evaluate Register
0x02A0 0324 - 0x02A0 033C	-	Reserved
0x02A0 0340	DRAE0	DMA Region Access Enable Register for Region 0
0x02A0 0344	DRAEH0	DMA Region Access Enable Register High for Region 0
0x02A0 0348	DRAE1	DMA Region Access Enable Register for Region 1
0x02A0 034C	DRAEH1	DMA Region Access Enable Register High for Region 1
0x02A0 0350	DRAE2	DMA Region Access Enable Register for Region 2
0x02A0 0354	DRAEH2	DMA Region Access Enable Register High for Region 2
0x02A0 0358	DRAE3	DMA Region Access Enable Register for Region 3
0x02A0 035C	DRAEH3	DMA Region Access Enable Register High for Region 3
0x02A0 0360	DRAE4	DMA Region Access Enable Register for Region 4
0x02A0 0364	DRAEH4	DMA Region Access Enable Register High for Region 4
0x02A0 0368	DRAE5	DMA Region Access Enable Register for Region 5
0x02A0 036C	DRAEH5	DMA Region Access Enable Register High for Region 5
0x02A0 0370	DRAE6	DMA Region Access Enable Register for Region 6
0x02A0 0374	DRAEH6	DMA Region Access Enable Register High for Region 6
0x02A0 0378	DRAE7	DMA Region Access Enable Register for Region 7
0x02A0 037C	DRAEH7	DMA Region Access Enable Register High for Region 7
0x02A0 0380	QRAE0	QDMA Region Access Enable Register for Region 0
0x02A0 0384	QRAE1	QDMA Region Access Enable Register for Region 1
0x02A0 0388	QRAE2	QDMA Region Access Enable Register for Region 2

Table 6-14. EDMA Channel Controller Registers (continued)

HEX ADDRESS	ACRONYM	REGISTER NAME
0x02A0 038C	QRAE3	QDMA Region Access Enable Register for Region 3
0x02A0 0390	QRAE4	QDMA Region Access Enable Register for Region 4
0x02A0 0394	QRAE5	QDMA Region Access Enable Register for Region 5
0x02A0 0398	QRAE6	QDMA Region Access Enable Register for Region 6
0x02A0 039C	QRAE7	QDMA Region Access Enable Register for Region 7
0x02A0 0400	Q0E0	Event Queue 0 Entry Register 0
0x02A0 0404	Q0E1	Event Queue 0 Entry Register 1
0x02A0 0408	Q0E2	Event Queue 0 Entry Register 2
0x02A0 040C	Q0E3	Event Queue 0 Entry Register 3
0x02A0 0410	Q0E4	Event Queue 0 Entry Register 4
0x02A0 0414	Q0E5	Event Queue 0 Entry Register 5
0x02A0 0418	Q0E6	Event Queue 0 Entry Register 6
0x02A0 041C	Q0E7	Event Queue 0 Entry Register 7
0x02A0 0420	Q0E8	Event Queue 0 Entry Register 8
0x02A0 0424	Q0E9	Event Queue 0 Entry Register 9
0x02A0 0428	Q0E10	Event Queue 0 Entry Register 10
0x02A0 042C	Q0E11	Event Queue 0 Entry Register 11
0x02A0 0430	Q0E12	Event Queue 0 Entry Register 12
0x02A0 0434	Q0E13	Event Queue 0 Entry Register 13
0x02A0 0438	Q0E14	Event Queue 0 Entry Register 14
0x02A0 043C	Q0E15	Event Queue 0 Entry Register 15
0x02A0 0440	Q1E0	Event Queue 1 Entry Register 0
0x02A0 0444	Q1E1	Event Queue 1 Entry Register 1
0x02A0 0448	Q1E2	Event Queue 1 Entry Register 2
0x02A0 044C	Q1E3	Event Queue 1 Entry Register 3
0x02A0 0450	Q1E4	Event Queue 1 Entry Register 4
0x02A0 0454	Q1E5	Event Queue 1 Entry Register 5
0x02A0 0458	Q1E6	Event Queue 1 Entry Register 6
0x02A0 045C	Q1E7	Event Queue 1 Entry Register 7
0x02A0 0460	Q1E8	Event Queue 1 Entry Register 8
0x02A0 0464	Q1E9	Event Queue 1 Entry Register 9
0x02A0 0468	Q1E10	Event Queue 1 Entry Register 10
0x02A0 046C	Q1E11	Event Queue 1 Entry Register 11
0x02A0 0470	Q1E12	Event Queue 1 Entry Register 12
0x02A0 0474	Q1E13	Event Queue 1 Entry Register 13
0x02A0 0478	Q1E14	Event Queue 1 Entry Register 14
0x02A0 047C	Q1E15	Event Queue 1 Entry Register 15
0x02A0 0480	Q2E0	Event Queue 2 Entry Register 0
0x02A0 0484	Q2E1	Event Queue 2 Entry Register 1
0x02A0 0488	Q2E2	Event Queue 2 Entry Register 2
0x02A0 048C	Q2E3	Event Queue 2 Entry Register 3
0x02A0 0490	Q2E4	Event Queue 2 Entry Register 4
0x02A0 0494	Q2E5	Event Queue 2 Entry Register 5
0x02A0 0498	Q2E6	Event Queue 2 Entry Register 6
0x02A0 049C	Q2E7	Event Queue 2 Entry Register 7
0x02A0 04A0	Q2E8	Event Queue 2 Entry Register 8
0x02A0 04A4	Q2E9	Event Queue 2 Entry Register 9

Table 6-14. EDMA Channel Controller Registers (continued)

HEX ADDRESS	ACRONYM	REGISTER NAME
0x02A0 04A8	Q2E10	Event Queue 2 Entry Register 10
0x02A0 04AC	Q2E11	Event Queue 2 Entry Register 11
0x02A0 04B0	Q2E12	Event Queue 2 Entry Register 12
0x02A0 04B4	Q2E13	Event Queue 2 Entry Register 13
0x02A0 04B8	Q2E14	Event Queue 2 Entry Register 14
0x02A0 04BC	Q2E15	Event Queue 2 Entry Register 15
0x02A0 04C0	Q3E0	Event Queue 3 Entry Register 0
0x02A0 04C4	Q3E1	Event Queue 3 Entry Register 1
0x02A0 04C8	Q3E2	Event Queue 3 Entry Register 2
0x02A0 04CC	Q3E3	Event Queue 3 Entry Register 3
0x02A0 04D0	Q3E4	Event Queue 3 Entry Register 4
0x02A0 04D4	Q3E5	Event Queue 3 Entry Register 5
0x02A0 04D8	Q3E6	Event Queue 3 Entry Register 6
0x02A0 04DC	Q3E7	Event Queue 3 Entry Register 7
0x02A0 04E0	Q3E8	Event Queue 3 Entry Register 8
0x02A0 04E4	Q3E9	Event Queue 3 Entry Register 9
0x02A0 04E8	Q3E10	Event Queue 3 Entry Register 10
0x02A0 04EC	Q3E11	Event Queue 3 Entry Register 11
0x02A0 04F0	Q3E12	Event Queue 3 Entry Register 12
0x02A0 04F4	Q3E13	Event Queue 3 Entry Register 13
0x02A0 04F8	Q3E14	Event Queue 3 Entry Register 14
0x02A0 04FC	Q3E15	Event Queue 3 Entry Register 15
0x02A0 0500 - 0x02A0 051C	-	Reserved
0x02A0 0520 - 0x02A0 05FC	-	Reserved
0x02A0 0600	QSTAT0	Queue 0 Status Register
0x02A0 0604	QSTAT1	Queue 1 Status Register
0x02A0 0608	QSTAT2	Queue Status Register 2
0x02A0 060C	QSTAT3	Queue Status Register 3
0x02A0 0610 - 0x02A0 061C	-	Reserved
0x02A0 0620	QWMTHRA	Queue Watermark Threshold A Register for Q[3:0]
0x02A0 0624	-	Reserved
0x02A0 0640	CCSTAT	EDMA3CC Status Register
0x02A0 0644 - 0x02A0 06FC	-	Reserved
0x02A0 0700 - 0x02A0 07FC	-	Reserved
0x02A0 0800	MPFAR	Memory Protection Fault Address Register
0x02A0 0804	MPFSR	Memory Protection Fault Status Register
0x02A0 0808	MPFCR	Memory Protection Fault Command Register
0x02A0 080C	MPPA0	Memory Protection Page Attribute Register 0
0x02A0 0810	MPPA1	Memory Protection Page Attribute Register 1
0x02A0 0814	MPPA2	Memory Protection Page Attribute Register 2
0x02A0 0818	MPPA3	Memory Protection Page Attribute Register 3
0x02A0 081C	MPPA4	Memory Protection Page Attribute Register 4
0x02A0 0820	MPPA5	Memory Protection Page Attribute Register 5
0x02A0 0824	MPPA6	Memory Protection Page Attribute Register 6
0x02A0 0828	MPPA7	Memory Protection Page Attribute Register 7
0x02A0 082C - 0x02A0 0FFC	-	Reserved
0x02A0 1000	ER	Event Register

Table 6-14. EDMA Channel Controller Registers (continued)

HEX ADDRESS	ACRONYM	REGISTER NAME
0x02A0 1004	ERH	Event Register High
0x02A0 1008	ECR	Event Clear Register
0x02A0 100C	ECRH	Event Clear Register High
0x02A0 1010	ESR	Event Set Register
0x02A0 1014	ESRH	Event Set Register High
0x02A0 1018	CER	Chained Event Register
0x02A0 101C	CERH	Chained Event Register High
0x02A0 1020	EER	Event Enable Register
0x02A0 1024	EERH	Event Enable Register High
0x02A0 1028	EECR	Event Enable Clear Register
0x02A0 102C	EECRH	Event Enable Clear Register High
0x02A0 1030	EESR	Event Enable Set Register
0x02A0 1034	EESRH	Event Enable Set Register High
0x02A0 1038	SER	Secondary Event Register
0x02A0 103C	SERH	Secondary Event Register High
0x02A0 1040	SECR	Secondary Event Clear Register
0x02A0 1044	SECRH	Secondary Event Clear Register High
0x02A0 1048 - 0x02A0 104C		Reserved
0x02A0 1050	IER	Interrupt Enable Register
0x02A0 1054	IERH	Interrupt Enable Register High
0x02A0 1058	IECR	Interrupt Enable Clear Register
0x02A0 105C	IECRH	Interrupt Enable Clear Register High
0x02A0 1060	IESR	Interrupt Enable Set Register
0x02A0 1064	IESRH	Interrupt Enable Set Register High
0x02A0 1068	IPR	Interrupt Pending Register
0x02A0 106C	IPRH	Interrupt Pending Register High
0x02A0 1070	ICR	Interrupt Clear Register
0x02A0 1074	ICRH	Interrupt Clear Register High
0x02A0 1078	IEVAL	Interrupt Evaluate Register
0x02A0 107C	-	Reserved
0x02A0 1080	QER	QDMA Event Register
0x02A0 1084	QEER	QDMA Event Enable Register
0x02A0 1088	QEECR	QDMA Event Enable Clear Register
0x02A0 108C	QEESR	QDMA Event Enable Set Register
0x02A0 1090	QSER	QDMA Secondary Event Register
0x02A0 1094	QSECR	QDMA Secondary Event Clear Register
0x02A0 1098 - 0x02A0 1FFF	-	Reserved
0x02A0 2000 - 0x02A0 2097	-	Shadow Region 0 Channel Registers
0x02A0 2098 - 0x02A0 21FF	-	Reserved
0x02A0 2200 - 0x02A0 2297	-	Shadow Region 1 Channel Registers
0x02A0 2298 - 0x02A0 23FF	-	Reserved
0x02A0 2400 - 0x02A0 2497	-	Shadow Region 2 Channel Registers
0x02A0 2498 - 0x02A0 25FF	-	Reserved
0x02A0 2600 - 0x02A0 2697	-	Shadow Region 3 Channel Registers
0x02A0 2698 - 0x02A0 27FF	-	Reserved
0x02A0 2800 - 0x02A0 2897	-	Shadow Region 4 Channel Registers
0x02A0 2898 - 0x02A0 29FF	-	Reserved

Table 6-14. EDMA Channel Controller Registers (continued)

HEX ADDRESS	ACRONYM	REGISTER NAME
0x02A0 2A00 - 0x02A0 2A97	-	Shadow Region 5 Channel Registers
0x02A0 2A98 - 0x02A0 2BFF	-	Reserved
0x02A0 2C00 - 0x02A0 2C97	-	Shadow Region 6 Channel Registers
0x02A0 2C98 - 0x02A0 2DFF	-	Reserved
0x02A0 2E00 - 0x02A0 2E97	-	Shadow Region 7 Channel Registers
0x02A0 2E98 - 0x02A0 2FFF	-	Reserved

Table 6-15 shows an abbreviation of the set of registers that make up the parameter set for each of 128 EDMA events. Each of the parameter register sets consist of eight 32-bit word entries. Table 6-16 shows the parameter set entry registers with relative memory address locations within each of the parameter sets.

Table 6-15. EDMA Parameter Set RAM

HEX ADDRESS RANGE	DESCRIPTION
0x02A0 4000 - 0x02A0 401F	Parameters Set 0 (8 32-bit words)
0x02A0 4020 - 0x02A0 403F	Parameters Set 1 (8 32-bit words)
0x02A0 4040 - 0x02A0 405F	Parameters Set 2 (8 32-bit words)
0x02A0 4060 - 0x02A0 407F	Parameters Set 3 (8 32-bit words)
0x02A0 4080 - 0x02A0 409F	Parameters Set 4 (8 32-bit words)
0x02A0 40A0 - 0x02A0 40BF	Parameters Set 5 (8 32-bit words)
...	...
0x02A0 4FC0 - 0x02A0 4FDF	Parameters Set 126 (8 32-bit words)
0x02A0 4FE0 - 0x02A0 4FFF	Parameters Set 127 (8 32-bit words)
...	...
0x02A0 5FC0 - 0x02A0 5FDF	Parameters Set 254 (8 32-bit words)
0x02A0 5FE0 - 0x02A0 5FFF	Parameters Set 255 (8 32-bit words)
...	...
0x02A0 7FC0 - 0x02A0 7FDF	Parameters Set 510 (8 32-bit words)
0x02A0 7FE0 - 0x02A0 7FFF	Parameters Set 511 (8 32-bit words)

Table 6-16. Parameter Set Entries

HEX OFFSET ADDRESS WITHIN THE PARAMETER SET	ACRONYM	PARAMETER ENTRY
0x0000	OPT	Option
0x0004	SRC	Source Address
0x0008	A_B_CNT	A Count, B Count
0x000C	DST	Destination Address
0x0010	SRC_DST_BIDX	Source B Index, Destination B Index
0x0014	LINK_BCNTRLD	Link Address, B Count Reload
0x0018	SRC_DST_CIDX	Source C Index, Destination C Index
0x001C	CCNT	C Count

Table 6-17. EDMA3 Transfer Controller 0 Registers

HEX ADDRESS RANGE	ACRONYM	REGISTER NAME
02A2 0000	PID	Peripheral Identification Register
02A2 0004	TCCFG	EDMA3TC Configuration Register
02A2 0008 - 02A2 00FC	-	Reserved

Table 6-17. EDMA3 Transfer Controller 0 Registers (continued)

HEX ADDRESS RANGE	ACRONYM	REGISTER NAME
02A2 0100	TCSTAT	EDMA3TC Channel Status Register
02A2 0104 - 02A2 011C	-	Reserved
02A2 0120	ERRSTAT	Error Register
02A2 0124	ERREN	Error Enable Register
02A2 0128	ERRCLR	Error Clear Register
02A2 012C	ERRDET	Error Details Register
02A2 0130	ERRCMD	Error Interrupt Command Register
02A2 0134 - 02A2 013C	-	Reserved
02A2 0140	RDRATE	Read Rate Register
02A2 0144 - 02A2 023C	-	Reserved
02A2 0240	SAOPT	Source Active Options Register
02A2 0244	SASRC	Source Active Source Address Register
02A2 0248	SACNT	Source Active Count Register
02A2 024C	SADST	Source Active Destination Address Register
02A2 0250	SABIDX	Source Active Source B-Index Register
02A2 0254	SAMPPRXY	Source Active Memory Protection Proxy Register
02A2 0258	SACNTRLD	Source Active Count Reload Register
02A2 025C	SASRCBREF	Source Active Source Address B-Reference Register
02A2 0260	SADSTBREF	Source Active Destination Address B-Reference Register
02A2 0264 - 02A2 027C	-	Reserved
02A2 0280	DFCNTRLD	Destination FIFO Set Count Reload
02A2 0284	DFSRCBREF	Destination FIFO Set Destination Address B Reference Register
02A2 0288	DFDSTBREF	Destination FIFO Set Destination Address B Reference Register
02A2 028C - 02A2 02FC	-	Reserved
02A2 0300	DFOPT0	Destination FIFO Options Register 0
02A2 0304	DFSRC0	Destination FIFO Source Address Register 0
02A2 0308	DFCNT0	Destination FIFO Count Register 0
02A2 030C	DFDST0	Destination FIFO Destination Address Register 0
02A2 0310	DFBIDX0	Destination FIFO BIDX Register 0
02A2 0314	DFMPPRXY0	Destination FIFO Memory Protection Proxy Register 0
02A2 0318 - 02A2 033C	-	Reserved
02A2 0340	DFOPT1	Destination FIFO Options Register 1
02A2 0344	DFSRC1	Destination FIFO Source Address Register 1
02A2 0348	DFCNT1	Destination FIFO Count Register 1
02A2 034C	DFDST1	Destination FIFO Destination Address Register 1
02A2 0350	DFBIDX1	Destination FIFO BIDX Register 1
02A2 0354	DFMPPRXY1	Destination FIFO Memory Protection Proxy Register 1
02A2 0358 - 02A2 037C	-	Reserved
02A2 0380	DFOPT2	Destination FIFO Options Register 2
02A2 0384	DFSRC2	Destination FIFO Source Address Register 2
02A2 0388	DFCNT2	Destination FIFO Count Register 2
02A2 038C	DFDST2	Destination FIFO Destination Address Register 2
02A2 0390	DFBIDX2	Destination FIFO BIDX Register 2
02A2 0394	DFMPPRXY2	Destination FIFO Memory Protection Proxy Register 2
02A2 0398 - 02A2 03BC	-	Reserved
02A2 03C0	DFOPT3	Destination FIFO Options Register 3
02A2 03C4	DFSRC3	Destination FIFO Source Address Register 3

Table 6-17. EDMA3 Transfer Controller 0 Registers (continued)

HEX ADDRESS RANGE	ACRONYM	REGISTER NAME
02A2 03C8	DFCNT3	Destination FIFO Count Register 3
02A2 03CC	DFDST3	Destination FIFO Destination Address Register 3
02A2 03D0	DFBIDX3	Destination FIFO BIDX Register 3
02A2 03D4	DFMPPRXY3	Destination FIFO Memory Protection Proxy Register 3
02A2 03D8 - 02A2 7FFF	-	Reserved

Table 6-18. EDMA3 Transfer Controller 1 Registers

HEX ADDRESS RANGE	ACRONYM	REGISTER NAME
02A2 8000	PID	Peripheral Identification Register
02A2 8004	TCCFG	EDMA3TC Configuration Register
02A2 8008 - 02A2 80FC	-	Reserved
02A2 8100	TCSTAT	EDMA3TC Channel Status Register
02A2 8104 - 02A2 811C	-	Reserved
02A2 8120	ERRSTAT	Error Register
02A2 8124	ERREN	Error Enable Register
02A2 8128	ERRCLR	Error Clear Register
02A2 812C	ERRDET	Error Details Register
02A2 8130	ERRCMD	Error Interrupt Command Register
02A2 8134 - 02A2 813C	-	Reserved
02A2 8140	RDRATE	Read Rate Register
02A2 8144 - 02A2 823C	-	Reserved
02A2 8240	SAOPT	Source Active Options Register
02A2 8244	SASRC	Source Active Source Address Register
02A2 8248	SACNT	Source Active Count Register
02A2 824C	SADST	Source Active Destination Address Register
02A2 8250	SABIDX	Source Active Source B-Index Register
02A2 8254	SAMPPRXY	Source Active Memory Protection Proxy Register
02A2 8258	SACNTRLD	Source Active Count Reload Register
02A2 825C	SASRCBREF	Source Active Source Address B-Reference Register
02A2 8260	SADSTBREF	Source Active Destination Address B-Reference Register
02A2 8264 - 02A2 827C	-	Reserved
02A2 8280	DFCNTRLD	Destination FIFO Set Count Reload
02A2 8284	DFSRCBREF	Destination FIFO Set Destination Address B Reference Register
02A2 8288	DFDSTBREF	Destination FIFO Set Destination Address B Reference Register
02A2 828C - 02A2 82FC	-	Reserved
02A2 8300	DFOPT0	Destination FIFO Options Register 0
02A2 8304	DFSRC0	Destination FIFO Source Address Register 0
02A2 8308	DFCNT0	Destination FIFO Count Register 0
02A2 830C	DFDST0	Destination FIFO Destination Address Register 0
02A2 8310	DFBIDX0	Destination FIFO BIDX Register 0
02A2 8314	DFMPPRXY0	Destination FIFO Memory Protection Proxy Register 0
02A2 8318 - 02A2 833C	-	Reserved
02A2 8340	DFOPT1	Destination FIFO Options Register 1
02A2 8344	DFSRC1	Destination FIFO Source Address Register 1
02A2 8348	DFCNT1	Destination FIFO Count Register 1
02A2 834C	DFDST1	Destination FIFO Destination Address Register 1
02A2 8350	DFBIDX1	Destination FIFO BIDX Register 1

Table 6-18. EDMA3 Transfer Controller 1 Registers (continued)

HEX ADDRESS RANGE	ACRONYM	REGISTER NAME
02A2 8354	DFMPPRXY1	Destination FIFO Memory Protection Proxy Register 1
02A2 8358 - 02A2 837C	-	Reserved
02A2 8380	DFOPT2	Destination FIFO Options Register 2
02A2 8384	DFSRC2	Destination FIFO Source Address Register 2
02A2 8388	DFCNT2	Destination FIFO Count Register 2
02A2 838C	DFDST2	Destination FIFO Destination Address Register 2
02A2 8390	DFBIDX2	Destination FIFO BIDX Register 2
02A2 8394	DFMPPRXY2	Destination FIFO Memory Protection Proxy Register 2
02A2 8398 - 02A2 83BC	-	Reserved
02A2 83C0	DFOPT3	Destination FIFO Options Register 3
02A2 83C4	DFSRC3	Destination FIFO Source Address Register 3
02A2 83C8	DFCNT3	Destination FIFO Count Register 3
02A2 83CC	DFDST3	Destination FIFO Destination Address Register 3
02A2 83D0	DFBIDX3	Destination FIFO BIDX Register 3
02A2 83D4	DFMPPRXY3	Destination FIFO Memory Protection Proxy Register 3
02A2 83D8 - 02A2 FFFF	-	Reserved

Table 6-19. EDMA3 Transfer Controller 2 Registers

HEX ADDRESS RANGE	ACRONYM	REGISTER NAME
02A3 0000	PID	Peripheral Identification Register
02A3 0004	TCCFG	EDMA3TC Configuration Register
02A3 0008 - 02A3 00FC	-	Reserved
02A3 0100	TCSTAT	EDMA3TC Channel Status Register
02A3 0104 - 02A3 011C	-	Reserved
02A3 0120	ERRSTAT	Error Register
02A3 0124	ERREN	Error Enable Register
02A3 0128	ERRCLR	Error Clear Register
02A3 012C	ERRDET	Error Details Register
02A3 0130	ERRCMD	Error Interrupt Command Register
02A3 0134 - 02A3 013C	-	Reserved
02A3 0140	RDRATE	Read Rate Register
02A3 0144 - 02A3 023C	-	Reserved
02A3 0240	SAOPT	Source Active Options Register
02A3 0244	SASRC	Source Active Source Address Register
02A3 0248	SACNT	Source Active Count Register
02A3 024C	SADST	Source Active Destination Address Register
02A3 0250	SABIDX	Source Active Source B-Index Register
02A3 0254	SAMPPRXY	Source Active Memory Protection Proxy Register
02A3 0258	SACNTRLD	Source Active Count Reload Register
02A3 025C	SASRCBREF	Source Active Source Address B-Reference Register
02A3 0260	SADSTBREF	Source Active Destination Address B-Reference Register
02A3 0264 - 02A3 027C	-	Reserved
02A3 0280	DFCNTRLD	Destination FIFO Set Count Reload
02A3 0284	DFSRCBREF	Destination FIFO Set Destination Address B Reference Register
02A3 0288	DFDSTBREF	Destination FIFO Set Destination Address B Reference Register
02A3 028C - 02A3 02FC	-	Reserved
02A3 0300	DFOPT0	Destination FIFO Options Register 0

Table 6-19. EDMA3 Transfer Controller 2 Registers (continued)

HEX ADDRESS RANGE	ACRONYM	REGISTER NAME
02A3 0304	DFSRC0	Destination FIFO Source Address Register 0
02A3 0308	DFCNT0	Destination FIFO Count Register 0
02A3 030C	DFDST0	Destination FIFO Destination Address Register 0
02A3 0310	DFBIDX0	Destination FIFO BIDX Register 0
02A3 0314	DFMPPRXY0	Destination FIFO Memory Protection Proxy Register 0
02A3 0318 - 02A3 033C	-	Reserved
02A3 0340	DFOPT1	Destination FIFO Options Register 1
02A3 0344	DFSRC1	Destination FIFO Source Address Register 1
02A3 0348	DFCNT1	Destination FIFO Count Register 1
02A3 034C	DFDST1	Destination FIFO Destination Address Register 1
02A3 0350	DFBIDX1	Destination FIFO BIDX Register 1
02A3 0354	DFMPPRXY1	Destination FIFO Memory Protection Proxy Register 1
02A3 0358 - 02A3 037C	-	Reserved
02A3 0380	DFOPT2	Destination FIFO Options Register 2
02A3 0384	DFSRC2	Destination FIFO Source Address Register 2
02A3 0388	DFCNT2	Destination FIFO Count Register 2
02A3 038C	DFDST2	Destination FIFO Destination Address Register 2
02A3 0390	DFBIDX2	Destination FIFO BIDX Register 2
02A3 0394	DFMPPRXY2	Destination FIFO Memory Protection Proxy Register 2
02A3 0398 - 02A3 03BC	-	Reserved
02A3 03C0	DFOPT3	Destination FIFO Options Register 3
02A3 03C4	DFSRC3	Destination FIFO Source Address Register 3
02A3 03C8	DFCNT3	Destination FIFO Count Register 3
02A3 03CC	DFDST3	Destination FIFO Destination Address Register 3
02A3 03D0	DFBIDX3	Destination FIFO BIDX Register 3
02A3 03D4	DFMPPRXY3	Destination FIFO Memory Protection Proxy Register 3
02A3 03D8 - 02A3 7FFF	-	Reserved

Table 6-20. EDMA3 Transfer Controller 3 Registers

HEX ADDRESS RANGE	ACRONYM	REGISTER NAME
02A3 8000	PID	Peripheral Identification Register
02A3 8004	TCCFG	EDMA3TC Configuration Register
02A3 8008 - 02A3 80FC	-	Reserved
02A3 8100	TCSTAT	EDMA3TC Channel Status Register
02A3 8104 - 02A3 811C	-	Reserved
02A3 8120	ERRSTAT	Error Register
02A3 8124	ERREN	Error Enable Register
02A3 8128	ERRCLR	Error Clear Register
02A3 812C	ERRDET	Error Details Register
02A3 8130	ERRCMD	Error Interrupt Command Register
02A3 8134 - 02A3 813C	-	Reserved
02A3 8140	RDRATE	Read Rate Register
02A3 8144 - 02A3 823C	-	Reserved
02A3 8240	SAOPT	Source Active Options Register
02A3 8244	SASRC	Source Active Source Address Register
02A3 8248	SACNT	Source Active Count Register
02A3 824C	SADST	Source Active Destination Address Register

Table 6-20. EDMA3 Transfer Controller 3 Registers (continued)

HEX ADDRESS RANGE	ACRONYM	REGISTER NAME
02A3 8250	SABIDX	Source Active Source B-Index Register
02A3 8254	SAMPPRXY	Source Active Memory Protection Proxy Register
02A3 8258	SACNTRLD	Source Active Count Reload Register
02A3 825C	SASRCBREF	Source Active Source Address B-Reference Register
02A3 8260	SADSTBREF	Source Active Destination Address B-Reference Register
02A3 8264 - 02A3 827C	-	Reserved
02A3 8280	DFCNTRLD	Destination FIFO Set Count Reload
02A3 8284	DFSRCBREF	Destination FIFO Set Destination Address B Reference Register
02A3 8288	DFDSTBREF	Destination FIFO Set Destination Address B Reference Register
02A3 828C - 02A3 82FC	-	Reserved
02A3 8300	DFOPT0	Destination FIFO Options Register 0
02A3 8304	DFSRC0	Destination FIFO Source Address Register 0
02A3 8308	DFCNT0	Destination FIFO Count Register 0
02A3 830C	DFDST0	Destination FIFO Destination Address Register 0
02A3 8310	DFBIDX0	Destination FIFO BIDX Register 0
02A3 8314	DFMPPRXY0	Destination FIFO Memory Protection Proxy Register 0
02A3 8318 - 02A3 833C	-	Reserved
02A3 8340	DFOPT1	Destination FIFO Options Register 1
02A3 8344	DFSRC1	Destination FIFO Source Address Register 1
02A3 8348	DFCNT1	Destination FIFO Count Register 1
02A3 834C	DFDST1	Destination FIFO Destination Address Register 1
02A3 8350	DFBIDX1	Destination FIFO BIDX Register 1
02A3 8354	DFMPPRXY1	Destination FIFO Memory Protection Proxy Register 1
02A3 8358 - 02A3 837C	-	Reserved
02A3 8380	DFOPT2	Destination FIFO Options Register 2
02A3 8384	DFSRC2	Destination FIFO Source Address Register 2
02A3 8388	DFCNT2	Destination FIFO Count Register 2
02A3 838C	DFDST2	Destination FIFO Destination Address Register 2
02A3 8390	DFBIDX2	Destination FIFO BIDX Register 2
02A3 8394	DFMPPRXY2	Destination FIFO Memory Protection Proxy Register 2
02A3 8398 - 02A3 83BC	-	Reserved
02A3 83C0	DFOPT3	Destination FIFO Options Register 3
02A3 83C4	DFSRC3	Destination FIFO Source Address Register 3
02A3 83C8	DFCNT3	Destination FIFO Count Register 3
02A3 83CC	DFDST3	Destination FIFO Destination Address Register 3
02A3 83D0	DFBIDX3	Destination FIFO BIDX Register 3
02A3 83D4	DFMPPRXY3	Destination FIFO Memory Protection Proxy Register 3
02A3 83D8 - 02A3 FFFF	-	Reserved

6.7 Reset Controller

The reset controller detects the different types of resets supported on the device and manages the distribution of those resets throughout the device.

The device has several types of resets: power-on reset, warm reset, max reset and system reset. [Table 6-21](#) explains further the types of reset, the reset initiator, and the effects of each reset on the chip. See [Section 6.7.9](#) for more information on the effects of each reset on the PLL controllers and their clocks.

Table 6-21. Device-Level Reset Types

TYPE	INITIATOR	EFFECT(s)
Power-on Reset	$\overline{\text{POR}}$ pin	Resets the entire chip including the test and emulation logic
Warm Reset	$\overline{\text{RESET}}$ pin	Resets everything except for the test and emulation logic and the Ethernet Subsystem
Max Reset	Emulator	Same as a warm reset
System Reset	PCI via the $\overline{\text{PRST}}$ pin	A system reset maintains memory contents and does not reset the test and emulation circuit and the Ethernet Subsystem. The device configuration pins are also not re-latched and system reset does not affect the state of the peripherals (enable/disable).

In addition to device-level global resets, the PSC provides the capability to cause local resets to peripherals and/or the CPU.

6.7.1 Power-on Reset ($\overline{\text{POR}}$ Pin)

Power-on reset (POR) is initiated by the $\overline{\text{POR}}$ pin and is used to reset the entire chip, including the test and emulation logic. Power-on reset is also referred to as a cold reset since the device usually goes through a power-up cycle. During power-up, the $\overline{\text{POR}}$ pin must be asserted (driven low) until the power supplies have reached their normal operating conditions. Note that a device power-up cycle is not required to initiate a power-on reset.

The following sequence must be followed during a power-on reset:

1. Wait for all power supplies to reach normal operating conditions while keeping the $\overline{\text{POR}}$ pin asserted (driven low). While $\overline{\text{POR}}$ is asserted, all pins will be in high-impedance mode. After the $\overline{\text{POR}}$ pin is deasserted (driven high), all Z-group pins, low-group pins, and high-group pins are set to their reset state and will remain at their reset state until configured by their respective peripheral. The clock and reset of each peripheral is determined by the default settings of the power and sleep controller (PSC).
2. Once all the power supplies are within valid operating conditions, the $\overline{\text{POR}}$ pin must remain asserted (low) for a minimum number of 256 CLKIN2 cycles. The PLL1 controller input clock, CLKIN1, and the PCI input clock, PCLK, must be valid during this time. PCLK is needed only if the PCI module is being used. If the DDR2 memory controller and the Ethernet Subsystem are not needed, CLKIN2 can be tied low and REFCLKP/REFCLKN can be connected to V_{SS} and CV_{DD} respectively. In this case, the $\overline{\text{POR}}$ pin must remain asserted (low) for a minimum of 256 CLKIN1 cycles after all power supplies have reached valid operating conditions. Within the low period of the $\overline{\text{POR}}$ pin, the following occurs:
 - (a) The reset signals flow to the entire chip (including the test and emulation logic), resetting modules that use reset asynchronously.
 - (b) The PLL1 controller clocks are started at the frequency of the system reference clock. The clocks are propagated throughout the chip to reset modules that use reset synchronously. By default, PLL1 is in reset and unlocked.
 - (c) The PLL2 controller clocks are started at the frequency of the system reference clock. PLL2 is held in reset. Since the PLL2 controller always operates in PLL mode, the system reference clock and all the system clocks are invalid at this point.
 - (d) The $\overline{\text{RESETSTAT}}$ pin stays asserted (low), indicating the device is in reset.
3. The $\overline{\text{POR}}$ pin may now be deasserted (driven high). When the $\overline{\text{POR}}$ pin is deasserted, the configuration pin values are latched, and the PLL controllers change their system clocks to their default divide-down values. PLL2 is taken out of reset and automatically starts its locking sequence. Other

device initialization is also started.

4. After device initialization is complete, the $\overline{\text{RESETSTAT}}$ pin is deasserted (driven high). By this time, PLL2 has already completed its locking sequence and is outputting a valid clock. The system clocks of both PLL controllers are allowed to finish their current cycles and then paused for 10 cycles of their respective system reference clocks. After the pause, the system clocks are restarted at their default divide-by settings.

The device is now out of reset; device execution begins as dictated by the selected boot mode.

6.7.2 Warm Reset ($\overline{\text{RESET}}$ Pin)

A warm reset has the same effect as a power-on reset, except that in this case, the test and emulation logic are not reset.

The following sequence must be followed during a warm reset:

1. Hold the $\overline{\text{RESET}}$ pin low for a minimum of 24 CLKIN1 cycles. Within the low period of the $\overline{\text{RESET}}$ pin, the following occurs:
 - (a) The Z-group pins, low-group pins, and the high-group pins are set to their reset state
 - (b) The reset signals flow to the entire chip (excluding the test and emulation logic), resetting modules that use reset asynchronously
 - (c) The PLL Controllers are reset. PLL1 switches back to PLL bypass mode, resetting all their registers to default values. Both PLL1 and PLL2 are placed in reset and lose lock. The PLL1 controller clocks start running at the frequency of the system reference clock. The clocks are propagated throughout the chip to reset modules that use reset synchronously.
 - (d) The $\overline{\text{RESETSTAT}}$ pin becomes active (low), indicating the device is in reset.
2. The $\overline{\text{RESET}}$ pin may now be released (driven inactive high). When the $\overline{\text{RESET}}$ pin is released, the configuration pin values are latched and the PLL controllers immediately change their system clocks to their default divide-down values. Other device initialization is also started.

After device initialization is complete, the $\overline{\text{RESETSTAT}}$ pin goes inactive (high). All system clocks are allowed to finish their current cycles and then paused for 10 cycles of their respective system reference clocks. After the pause the system clocks are restarted at their default divide-by settings.

The clock and reset of each peripheral is determined by the default settings of the PSC.

The device is now out of reset, device execution begins as dictated by the selected boot mode.

6.7.3 Maximum Reset

A maximum (max) reset is initiated by the emulator. The effects are the same as a warm reset, except the device boot and configuration pins are not re-latched. The emulator initiates a maximum reset via the ICEPICK module. This ICEPICK initiated reset is nonmaskable.

The max reset sequence is as follows:

1. Max reset is initiated by the emulator. During this time, the following happens:
 - (a) The reset signals flow to the entire chip, resetting all the modules on chip except the test and emulation logic.
 - (b) The PLL controllers are reset, PLL1 switches back to PLL bypass mode, resetting all their registers to default values. Both PLL1 and PLL2 are placed in reset and lose lock.
 - (c) The $\overline{\text{RESETSTAT}}$ pin becomes asserted (low), indicating the device is in reset.
2. After device initialization is complete, the PLL Controllers pause the system clocks for 10 cycles. At the end of these 10 cycles, the $\overline{\text{RESETSTAT}}$ pin is deasserted (driven high). At this point, the following occurs:
 - (a) The I/O pins are controlled by the default peripherals (default peripherals are determined by PINMUX register).
 - (b) The clock and reset of each peripheral is determined by the default settings of the power and sleep controller (PSC).

- (c) The C64x+ begins executing from DSPBOOTADDR (determined by bootmode selection).

After the reset sequence, the boot sequence begins. Since the boot and configuration pins are not latched with a max reset, the previous values (as shown in the BOOTCFG register) are used to select the bootmode. For more details on the boot sequence, see the *Using the TMS320DM647/DM648 Bootloader Application Report* (literature number [SPRAAJ1](#)). After the boot sequence, follow the software initialization sequence.

6.7.4 System Reset

A system reset maintains memory contents and does not reset the clock logic or the test and emulation circuitry. The device configuration pins are also not re-latched and the state of the peripherals (enabled/disabled) is also not affected. A system reset is initiated by the $\overline{\text{PRST}}$ pin of PCI peripheral.

During a system reset, the following happens:

1. The RESETSTAT pin goes low to indicate an internal reset is being generated. The reset is allowed to propagate through the system. Internal system clocks are not affected.
2. After the internal reset signal has propagated, the PLL controllers pause and restart their system clocks for about 10 cycles of their system reference clocks, but retain their configuration. The PLLs also remain locked.
3. The boot sequence is started after the system clocks are restarted. Since the configuration pins (including the BOOTMODE[3:0] pins) are not latched with a system reset, the previous values, as shown in the BOOTCFG register, are used to select the boot mode.

6.7.5 Peripheral Local Reset

The user can configure the local reset and clock state of a peripheral through programming the PSC. [Table 6-2](#) identifies the LPSC numbers and the peripherals capable of being locally reset by the PSC. For more detailed information on the programming of these peripherals by the PSC, see the *TMS320DM647/TMS320DM648 DSP Subsystem Reference Guide* (literature number [SPRUEU6](#)).

6.7.6 Reset Priority

If any of the above reset sources occur simultaneously, the PLLCTRL processes only the highest priority reset request. The reset request priorities are as follows (high to low):

- Power-on Reset
- Maximum Reset
- Warm Reset
- System Reset

6.7.7 Reset Controller Register

The reset type status (RSTYPE) register is the only register for the reset controller.

The RSTYPE register latches the cause of the last reset. If multiple reset sources occur simultaneously, this register latches the highest priority reset source. The reset type status register is shown in Figure 6-9 and described in Table 6-22.

Figure 6-9. Reset Type Status Register (RSTYPE)

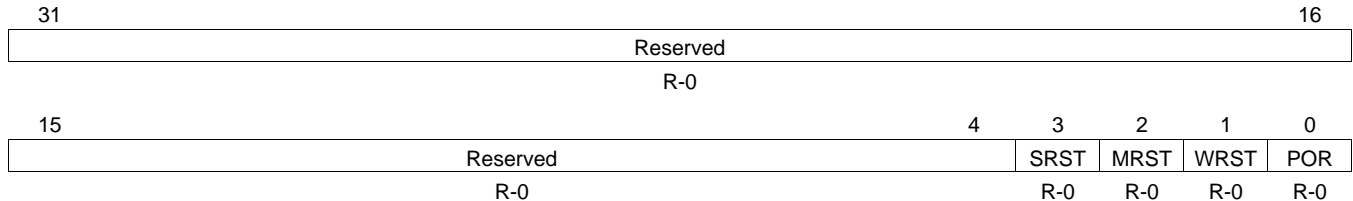

LEGEND: R/W = Read/Write; R = Read only; -n = value after reset

Table 6-22. Reset Type Status Register (RSTYPE) Field Descriptions

Bit	Field	Value	Description
31:4	Reserved		Reserved. The reserved bit location is always read as 0. A value written to this field has no effect.
3	SRST	0	System Reset was not the last reset to occur.
		1	System Reset was the last reset to occur.
2	MRST	0	Max Reset was not the last reset to occur.
		1	Max Reset was the last reset to occur.
1	WRST	0	Warm Reset was not the last reset to occur.
		1	Warm Reset was the last reset to occur.
0	POR	0	Power-on Reset was not the last reset to occur.
		1	Power-on Reset was the last reset to occur.

6.7.8 Pin Behaviors at Reset

During normal operation, devices pins are controlled by the selected peripheral. During device level global reset, the pin behaviors are classified into the following Reset Groups:

- **Z Group:** These pins are 3-stated when a device-level global reset source (e.g., \overline{POR} , \overline{RESET} , or Max Reset) is asserted. When the reset source is de-asserted, these pins remain 3-stated until configured otherwise by their respective peripheral (after the peripheral is enabled by the PSC).
- **Z/High Group:** These pins are 3-stated when a device-level global reset source (e.g., \overline{POR} , \overline{RESET} , or Max Reset) is asserted. When the reset source is de-asserted, these pins drive a logic High.
- **Z/Low Group:** These pins are 3-stated when a device-level global reset source (e.g. \overline{POR} , \overline{RESET} , or Max Reset) is asserted. When the reset source is de-asserted, these pins drive a logic Low.
- **DDR2 Z/High Group:** These pins are 3-stated when a device-level global reset source (e.g. \overline{POR} , \overline{RESET} , or Max Reset) is asserted. When the reset source is de-asserted, these pins are Driven High.
- **DDR2 Low/High Group:** These pins are driven Low when a device-level global reset source (e.g. \overline{POR} , \overline{RESET} , or Max Reset) is asserted. When the reset source is de-asserted, these pins are Driven High.
- **DDR2 High/Low Group:** These pins are driven High when a device-level global reset source (e.g. \overline{POR} , \overline{RESET} , or Max Reset) is asserted. When the reset source is de-asserted, these pins are Driven Low.

- **Clock Group:** These clock pins are toggling by default. They pause momentarily before $\overline{\text{RESETSTAT}}$ is de-asserted (high).

Table 6-23 lists the Reset Group for each pin.

Table 6-23. Pin Behaviors at Reset

Pin Name	Reset Group
CLKIN1	Z Group
CLKIN2	Z Group
REFCLKN	Z Group
REFCLKP	Z Group
SYSCLK5	Z Group
TCLK	Z Group
TDI	Z Group
TDO	Z Group
TMS	Z Group
$\overline{\text{TRST}}$	Z Group
EMU0	Z Group
EMU1	Z Group
EMU2	Z Group
EMU3	Z Group
EMU4	Z Group
EMU5	Z Group
EMU6	Z Group
EMU7	Z Group
EMU8	Z Group
EMU9	Z Group
EMU10	Z Group
EMU11	Z Group
NMI	Z Group
$\overline{\text{RESET}}$	Z Group
$\overline{\text{POR}}$	Z Group
AD00/HD00	Z Group
AD01/HD01	Z Group
AD02/HD02	Z Group
AD03/HD03	Z Group
AD04/HD04	Z Group
AD05/HD05	Z Group
AD06/HD06	Z Group
AD07/HD07	Z Group
AD08/HD08	Z Group
AD09/HD09	Z Group
AD10/HA10	Z Group
AD11/HD11	Z Group
AD12/HD12	Z Group
AD13/HD13	Z Group
AD14/HD14	Z Group
AD15/HD15	Z Group
AD16/HD16	Z Group
AD17/HD17	Z Group

Table 6-23. Pin Behaviors at Reset (continued)

Pin Name	Reset Group
AD18/HS18	Z Group
AD19/HD19	Z Group
AD20/HD20	Z Group
AD21/HD21	Z Group
AD22/HD22	Z Group
AD23/HD23	Z Group
AD24/HD24	Z Group
AD25/HS25	Z Group
AD26/HD26	Z Group
AD27/AD27	Z Group
AD28/HD28	Z Group
AD29/HD29	Z Group
AD30/HD30	Z Group
AD31/HD31	Z Group
PPAR/HAS	Z Group
PSTOP/HCNTL0	Z Group
PDEVSEL/HCNTL1	Z Group
PPERR/HCS	Z Group
PSERR/HDS1	Z Group
PCBE0/GP04	Z Group
PCBE2/HRW	Z Group
PCBE3/GP07	Z Group
PCLK/HHWIL	Z Group
PGNT/GPO0	Z Group
PRST/GPO1	Z Group
PINTA/GPO2	Z Group
PREQ/GPO3	Z Group
PTRDY/GPO5	Z Group
PIDSEL/GPO6	Z Group
DEVICEENABLE0/AEA20	Z Group
EMIBWIDTH/AEA22	Z Group
FASTBOOT/AEA21	Z Group
UHPIEN	Z Group
HPIWIDTH/AEA16	Z Group
RSV_BOOT/AEA15	Z Group
PCI66/AEA18	Z Group
BOOTMODE0/AEA11	Z Group
BOOTMODE1/AEA12	Z Group
BOOTMODE2/AEA13	Z Group
BOOTMODE3/AEA14	Z Group
SCL	Z Group
SDA	Z Group
SGMII0RXN	Z Group
SGMII0RXP	Z Group
SGMII1RXN	Z Group
SGMII1RXP	Z Group
SGMII0TXN	Z Group

Table 6-23. Pin Behaviors at Reset (continued)

Pin Name	Reset Group
SGMII0TXP	Z Group
SGMII1TXN	Z Group
SGMII1TXP	Z Group
MDIO	Z Group
SPICLK	Z Group
$\overline{\text{SPICS1}}$ /UARTTX	Z Group
$\overline{\text{SPICS2}}$ /UARTRX	Z Group
SPIDI/UARTRTS	Z Group
SPIDO/UARTCTS	Z Group
T0INP12/GP08	Z Group
T0OUT12/GP09	Z Group
T1INPL/GP10	Z Group
T1OUT12/GP11	Z Group
AHCLKR	Z Group
ALHCLKX	Z Group
ACLKR	Z Group
ACLKX	Z Group
AFSR	Z Group
AFSX	Z Group
AXR0	Z Group
AXR1	Z Group
AXR2	Z Group
AXR3	Z Group
AXR4	Z Group
AXR5	Z Group
AXR6	Z Group
AXR7	Z Group
STCLK/AXR8	Z Group
VDAC/AXR9	Z Group
AMUTEIN	Z Group
AMUTE	Z Group
VP0CLK0	Z Group
VP0CLK1	Z Group
VP0CTL0	Z Group
VP0CTL1	Z Group
VP0CTL2	Z Group
VP0D02	Z Group
VP0D03	Z Group
VP0D04	Z Group
VP0D05	Z Group
VP0D06	Z Group
VP0D07	Z Group
VP0D08	Z Group
VP0D09	Z Group
VP0D12/GP12	Z Group
VP0D13/GP13	Z Group
VP0D14/GP14	Z Group

Table 6-23. Pin Behaviors at Reset (continued)

Pin Name	Reset Group
VP0D15/GP15	Z Group
VP0D16	Z Group
VP0D17	Z Group
VP0D18	Z Group
VP0D19	Z Group
VP1CLK0	Z Group
VP1CLK1	Z Group
VP1CTL0	Z Group
VP1CTL1	Z Group
VP1CTL2	Z Group
VP1D02/GP16	Z Group
VP1D03/GP17	Z Group
VP1D04/GP18	Z Group
VP1D05/GP19	Z Group
VP1D06/GP20	Z Group
VP1D07/GP21	Z Group
VP1D08/GP22	Z Group
VP1D09/GP23	Z Group
VP1D12/GP24	Z Group
VP1D13/GP25	Z Group
VP1D14/GP26	Z Group
VP1D15/GP27	Z Group
VP1D16/GP28	Z Group
VP1D17/GP29	Z Group
VP1D18/GP30	Z Group
VP1D19/GP31	Z Group
VP2CLK0	Z Group
VP2CLK1/VCLK	Z Group
VP2CTL0	Z Group
VP2CTL1	Z Group
VP2CTL2/ $\overline{\text{SCRUN}}$	Z Group
VP2D02	Z Group
VP2D03	Z Group
VP2D04	Z Group
VP2D05	Z Group
VP2D06	Z Group
VP2D07	Z Group
VP2D08	Z Group
VP2D09	Z Group
VP2D12/VRXD0	Z Group
VP2D13/VRXD1	Z Group
VP2D14/VRXD2	Z Group
VP2D15/VRXD3	Z Group
VP3CLK1/AECLKOUT	Z Group
VP3CTL0/ $\overline{\text{AAWE}}$ / $\overline{\text{ASWE}}$	Z Group
VP3CTL1/ $\overline{\text{AR}}$ / $\overline{\text{W}}$	Z Group
VP3CTL2/ $\overline{\text{AAOE}}$ / $\overline{\text{ASOE}}$	Z Group

Table 6-23. Pin Behaviors at Reset (continued)

Pin Name	Reset Group
VP3D02/AED00	Z Group
VP3D03/AED01	Z Group
VP3D04/AED02	Z Group
VP3D05/AED03	Z Group
VP3D06/AED04	Z Group
VP3D07/AED05	Z Group
VP3D08/AED06	Z Group
VP3D09/AED07	Z Group
VP3D12/AED08	Z Group
VP3D13/AED09	Z Group
VP3D14/AED10	Z Group
VP3D15/AED11	Z Group
VP3D16/AED12	Z Group
VP3D17/AED13	Z Group
VP3D18/AED14	Z Group
VP3D19/AED15	Z Group
VP4CLK1	Z Group
VP4CTL0/ABA0	Z Group
VP4CTL1/ABA1	Z Group
VP4CTL2/ASADS/ASRE	Z Group
VP4D02/ABE00	Z Group
VP4D03/ABE01	Z Group
VP4D04/AEA10	Z Group
VP4D05	Z Group
VP4D06/ACE2	Z Group
VP4D07/ACE3	Z Group
VP4D08/AEA00	Z Group
VP4D09/AEA01	Z Group
VP4D12/AEA02	Z Group
VP4D13/AEA03	Z Group
VP4D14/AEA04	Z Group
VP4D15/AEA05	Z Group
VP4D16/AEA06	Z Group
VP4D17/AEA07	Z Group
VP4D18/AEA08	Z Group
VP4D19/AEA09	Z Group
AEA23	Z Group
AEA19	Z Group
AEA17	Z Group
MDCLK	Z/High Group
VP4CLK0/AARDY	Z/High Group
PFRAME/HINT	Z/High Group
PIRDY/HRDY	Z/Low Group
VP2D16/VTXD0	Z/Low Group
VP2D17/VTXD1	Z/Low Group
VP2D18/VTXD2	Z/Low Group
VP2D19/VTXD3	Z/Low Group

Table 6-23. Pin Behaviors at Reset (continued)

Pin Name	Reset Group
DDR_D00	DDR2 Z Group
DDR_D01	DDR2 Z Group
DDR_D02	DDR2 Z Group
DDR_D03	DDR2 Z Group
DDR_D04	DDR2 Z Group
DDR_D05	DDR2 Z Group
DDR_D06	DDR2 Z Group
DDR_D07	DDR2 Z Group
DDR_D08	DDR2 Z Group
DDR_D09	DDR2 Z Group
DDR_D10	DDR2 Z Group
DDR_D11	DDR2 Z Group
DDR_D12	DDR2 Z Group
DDR_D13	DDR2 Z Group
DDR_D14	DDR2 Z Group
DDR_D15	DDR2 Z Group
DDR_D16	DDR2 Z Group
DDR_D17	DDR2 Z Group
DDR_D18	DDR2 Z Group
DDR_D19	DDR2 Z Group
DDR_D20	DDR2 Z Group
DDR_D21	DDR2 Z Group
DDR_D22	DDR2 Z Group
DDR_D23	DDR2 Z Group
DDR_D24	DDR2 Z Group
DDR_D25	DDR2 Z Group
DDR_D26	DDR2 Z Group
DDR_D27	DDR2 Z Group
DDR_D28	DDR2 Z Group
DDR_D29	DDR2 Z Group
DDR_D30	DDR2 Z Group
DDR_D31	DDR2 Z Group
DDR_DQGATE1	DDR2 Z Group
DDR_DQGATE3	DDR2 Z Group
DDR_DQS[0]P	DDR2 Z Group
DDR_DQS[1]P	DDR2 Z Group
DDR_DQS[2]P	DDR2 Z Group
DDR_DQS[3]P	DDR2 Z Group
DDR_DQS[0]N	DDR2 Z Group
DDR_DQS[1]N	DDR2 Z Group
DDR_DQS[2]N	DDR2 Z Group
DDR_DQS[3]N	DDR2 Z Group
DDR_DQM[0]	DDR2 Z/High Group
DDR_DQM[1]	DDR2 Z/High Group
DDR_DQM[2]	DDR2 Z/High Group
DDR_DQM[3]	DDR2 Z/High Group
$\overline{\text{DDR_CAS}}$	DDR2 High Group

Table 6-23. Pin Behaviors at Reset (continued)

Pin Name	Reset Group
$\overline{\text{DDR_RAS}}$	DDR2 High Group
$\overline{\text{DDR_WE}}$	DDR2 High Group
DDR_A00	DDR2 Low Group
DDR_A01	DDR2 Low Group
DDR_A02	DDR2 Low Group
DDR_A03	DDR2 Low Group
DDR_A04	DDR2 Low Group
DDR_A05	DDR2 Low Group
DDR_A06	DDR2 Low Group
DDR_A07	DDR2 Low Group
DDR_A08	DDR2 Low Group
DDR_A09	DDR2 Low Group
DDR_A10	DDR2 Low Group
DDR_A11	DDR2 Low Group
DDR_A12	DDR2 Low Group
DDR_A13	DDR2 Low Group
DDR_ODT0	DDR2 Low Group
DDR_ODT1	DDR2 Low Group
DDR_CKE	DDR2 Low Group
DDR_DQGATE0	DDR2 Low Group
DDR_DQGATE2	DDR2 Low Group
DDR_BA[0]	DDR2 Low/High Group
DDR_BA[1]	DDR2 Low/High Group
DDR_BA[2]	DDR2 Low/High Group
$\overline{\text{DDR_CS}}$	DDR2 High/Low Group
DDR_CLKP	Clock
DDR_CLKN	Clock
VP3CLK0/AECLKIN	Clock
RESETSTAT	Reflects $\overline{\text{POR}}$ or $\overline{\text{RESET}}$ value

6.7.9 Reset Electrical Data/Timing

NOTE

If a configuration pin must be routed out from the device, the internal pullup/pulldown (IPU/IPD) resistor should not be relied upon; TI recommends the use of an external pullup/pulldown resistor.

Table 6-24. Timing Requirements for Reset^{(1) (2)} (see Figure 6-10)

NO.			720, 800, 900, 1100		UNIT
			MIN	MAX	
5	$t_{w(\text{POR})}$	Pulse duration, $\overline{\text{POR}}$ low ⁽³⁾	256D		ns
6	$t_{w(\text{RESET})}$	Pulse duration, $\overline{\text{RESET}}$ low	24C		ns
7	$t_{su(\text{boot})}$	Setup time, boot mode and configuration pins valid before $\overline{\text{POR}}$ high or $\overline{\text{RESET}}$ high ⁽⁴⁾	6P		ns

(1) C = 1/CLKIN1 clock frequency in ns

(2) D = 1/CLKIN2 clock frequency in ns

(3) If CLKIN2 is not used, $t_{w(\text{POR})}$ must be measured in terms of CLKIN1 cycles; otherwise, use the slower of the CLKIN1,CLKIN2 cycles.

(4) P = 1/CPU clock frequency in nanoseconds

Table 6-24. Timing Requirements for Reset^{(1) (2)} (see Figure 6-10) (continued)

NO.			720, 800, 900, 1100		UNIT
			MIN	MAX	
8	$t_{h(\text{boot})}$	Hold time, boot mode and configuration pins valid after $\overline{\text{POR}}$ high or $\overline{\text{RESET}}$ high ⁽⁴⁾	6P		ns

Table 6-25. Switching Characteristics Over Recommended Operating Conditions During Reset⁽¹⁾ (see Figure 6-10)

NO.	PARAMETER	720, 800, 900, 1100		UNIT
		MIN	MAX	
9	$t_{d(\text{PORH-RSTATH})}$ Delay time, $\overline{\text{POR}}$ high AND $\overline{\text{RESET}}$ high to $\overline{\text{RESETSTAT}}$ high	1500C		ns

(1) C = 1/CLKIN1 clock frequency in ns.

- Z group consists of: all I/O/Z and O/Z pins, except for Low and High group pins. Pins become high impedance as soon as their respective power supply has reached normal operating conditions. Pins remain in high impedance until configured otherwise by their respective peripherals.
- Low group consists of pins that become low as soon as their respective power supply has reached normal operating conditions. Pins remain low until configured otherwise by their respective peripheral.
- High group consists of pins that become high as soon as their respective power supply has reached normal operating conditions. Pins remain high until configured otherwise by their respective peripheral.
- All peripherals must be enabled through software following a power-on reset; for more details, see [Section 6.7.1, Power-on Reset](#).
- For power-supply sequence requirements, see [Section 6.3.1](#).

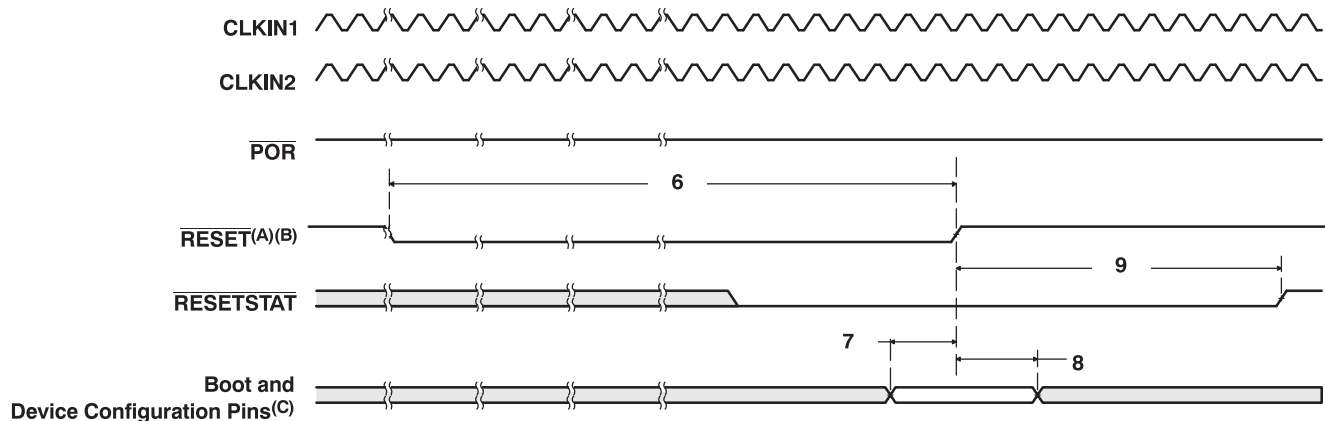

- $\overline{\text{RESET}}$ should be used only after the device has been powered up. For more details on the use of the $\overline{\text{RESET}}$ pin, see [Section 6.7, Reset Controller](#).
- A reset signal is generated internally during a Warm Reset. This internal reset signal has the same effect as the $\overline{\text{RESET}}$ pin during a Warm Reset.
- Boot and Device Configuration Inputs (during reset) include AEA[22:11], and UHPIEN.

Figure 6-10. Warm Reset and Max Reset Timing

6.8 Interrupts

The C64x+ DSP interrupt controller combines device events into 12 prioritized interrupts. The source for each of the 12 CPU interrupts is user programmable. Also, the interrupt controller controls the generation of the CPU exception, NMI, and emulation interrupts and the generation of AEG events. [Table 6-27](#) summarizes the C64x+ interrupt controller registers and memory locations. For more details on DSP interrupt control, see *TMS320DM647/TMS320DM648 DSP Subsystem Reference Guide* (literature number [SPRUEU6](#)).

Table 6-26. DSP Interrupt Events

DSP INTERRUPT EVENT NUMBER	EVENT	INTERRUPT SOURCE
0	EVT0	Output of event combiner 0, for events 1 – 31
1	EVT1	Output of event combiner 1, for events 32 – 63
2	EVT2	Output of event combiner 2, for events 64 – 95
3	EVT33	Output of event combiner 3, for events 96 – 127
4-8		Reserved
9	EMU_DTDMA	ECM interrupt for: <ul style="list-style-type: none"> • Host scan access event • DTDMA transfer complete event • AET interrupt event
10	Reserved	Reserved
11	EMU_RTDXRX	RTDX receive complete event
12	EMU_RTDXTX	RTDX transmit complete event
13	IDMA0 EMC	C64x+ EMC 0 event
14	IDMA1 EMC	C64x+ EMC 1 event
15	DSPINT	Host (PCI/HPI) to DSP interrupt event
16	I2CINT	I2C interrupt event
17	Reserved	Reserved
18	AEASYNCERR event	EMIFA Error Interrupt event
19	TINT2L	Timer interrupt low event
20	TINT2H	Timer interrupt high event
21	TINT3L	Timer interrupt low event
22	TINT3H	Timer interrupt high event
23	PSCINT	PSC-ALLINT event
24	TPCC_GINT	EDMA3 channel global completion interrupt event
25	SPIINT0	SPI Interrupt
26	SPIINT1	SPI Interrupt
27	DSQINT	VICP – Sqr (DSP int)
28	IMXINT	VICP – IMX
29	VLCDINT	VICP - VLCD
30 -31	Reserved	Reserved
32	RX_PULSE	Ethernet Subsystem RX pulse interrupt event
33	RX_THRESH_PULSE	Ethernet Subsystem RX threshold interrupt event
34	TX_PULSE	Ethernet Subsystem TX pulse interrupt event
35	MISC_PULSE	Ethernet Subsystem MISC pulse interrupt event
36	UART_INT	UART Interrupt
37	VP0_INT	VP0 Interrupt
38	VP1_INT	VP1 Interrupt
39	VP2_INT	VP2 Interrupt
40	VP3_INT	VP3 Interrupt

Table 6-26. DSP Interrupt Events (continued)

DSP INTERRUPT EVENT NUMBER	EVENT	INTERRUPT SOURCE
41	VP4_INT	VP4 Interrupt
42	GPIO_BNK1_INT	(GPIO16:31) GPIO Bank 1 Interrupt event
43	AXINT	TX Interrupt McASP
44	ARINT	RX Interrupt McASP
45-49		Reserved
50	VINT	VLYNQ Pulse Interrupt event
51	GPINT0	GPIO Interrupt event
52	GPINT1	GPIO Interrupt event
53	GPINT2	GPIO Interrupt event
54	GPINT3	GPIO Interrupt event
55	GPINT4	GPIO Interrupt event
56	GPINT5	GPIO Interrupt event
57	GPINT6	GPIO Interrupt event
58	GPINT7	GPIO Interrupt event
59	GPINT8	GPIO Interrupt event
60	GPINT9	GPIO Interrupt event
61	GPINT10	GPIO Interrupt event
62	GPINT11	GPIO Interrupt event
63	GPINT12	GPIO Interrupt
64	GPINT13	GPIO Interrupt
65	GPINT14	GPIO Interrupt event
66	GPINT15	GPIO Interrupt event
67	TINT0L	Timer interrupt low event
68	TINT0H	Timer interrupt high event
69	TINT1L	Timer interrupt low event
70	TINT1H	Timer interrupt high event
71	EDMA3CC_INT0	EDMA3CC Completion Interrupt - Mask0 event
72	EDMA3CC_INT1	EDMA3CC Completion Interrupt – Mask1 event
73	EDMA3CC_INT2	EDMA3CC Completion Interrupt – Mask2 event
74	EDMA3CC_INT3	EDMA3CC Completion Interrupt – Mask3 event
75	EDMA3CC_INT4	EDMA3CC Completion Interrupt – Mask4 event
76	EDMA3CC_INT5	EDMA3CC Completion Interrupt – Mask5 event
77	EDMA3CC_INT6	EDMA3CC Completion Interrupt – Mask6 event
78	EDMA3CC_INT7	EDMA3CC Completion Interrupt – Mask7 event
79	EDMA3CC_ERRINT	EDMA3CC Error Interrupt event
80	EDMA3CC_MPINT	EDMA3CC Memory Protection Interrupt event
81	EDMA3TC0_ERRINT	EDMA3TC0 Error Interrupt event
82	EDMA3TC1_ERRINT	EDMA3TC1 Error Interrupt event
83	EDMA3TC2_ERRINT	EDMA3TC2 Error Interrupt event
84	EDMA3TC3_ERRINT	EDMA3TC3 Error Interrupt event
85	Reserved	Reserved
86	Reserved	Reserved
87	Reserved	Reserved
88	Reserved	Reserved
89	Reserved	Reserved
90	Reserved	Reserved

Table 6-26. DSP Interrupt Events (continued)

DSP INTERRUPT EVENT NUMBER	EVENT	INTERRUPT SOURCE
91	Reserved	Reserved
92	Reserved	Reserved
93	Reserved	Reserved
94	Reserved	Reserved
95	Reserved	Reserved
96	INTERR	C64x+ Interrupt Controller Dropped CPU Interrupt Event
97	EMC_IDMAERR	C64x+ EMC Invalid IDMA Parameters event
98	Reserved	Reserved
99	Reserved	Reserved
100	EFIINTA	EFI Interrupt from side A event
101	EFIINTB	EFI Interrupt from side B event
102 - 112	Reserved	Reserved
113	L1P_ED	L1P Single bit error detected during DMA read event
114-115	Reserved	Reserved
116	L2_ED1	L2 single bit error detected event
117	L2_ED2	L2 two bit error detected event
118	PDC_INT	Power Down sleep interrupt event
119	Reserved	Reserved
120	L1P_CMPA	L1P CPU memory protection fault event
121	L1P_DMPA	L1P DMA memory protection fault event
122	L1D_CMPA	L1D CPU memory protection fault event
123	L1D_DMPA	L1D DMA memory protection fault event
124	L2_CMPA	L2 CPU memory protection fault event
125	L2_DMPA	L2 DMA memory protection fault event
126	IDMA_CMPA	IDMA CPU memory protection fault event
127	IDMA_BUSERR	IDMA bus error interrupt event

Table 6-27. C64x+ Interrupt Controller Registers

HEX ADDRESS	ACRONYM	REGISTER DESCRIPTION
0x0180 0000	EVTFLAG0	Event flag register 0
0x0180 0004	EVTFLAG1	Event flag register 1
0x0180 0008	EVTFLAG2	Event flag register 2
0x0180 000C	EVTFLAG3	Event flag register 3
0x0180 0020	EVTSET0	Event set register 0
0x0180 0024	EVTSET1	Event set register 1
0x0180 0028	EVTSET2	Event set register 2
0x0180 002C	EVTSET3	Event set register 3
0x0180 0040	EVTCLR0	Event clear register 0
0x0180 0044	EVTCLR1	Event clear register 1
0x0180 0048	EVTCLR2	Event clear register 2
0x0180 004C	EVTCLR3	Event clear register 3
0x0180 0080	EVTMASK0	Event mask register 0
0x0180 0084	EVTMASK1	Event mask register 1
0x0180 0088	EVTMASK2	Event mask register 2
0x0180 008C	EVTMASK3	Event mask register 3
0x0180 00A0	MEVTFLAG0	Masked event flag register 0
0x0180 00A4	MEVTFLAG1	Masked event flag register 1
0x0180 00A8	MEVTFLAG2	Masked event flag register 2
0x0180 00AC	MEVTFLAG3	Masked event flag register 3
0x0180 00C0	EXPMASK0	Exception mask register 0
0x0180 00C4	EXPMASK1	Exception mask register 1
0x0180 00C8	EXPMASK2	Exception mask register 2
0x0180 00CC	EXPMASK3	Exception mask register 3
0x0180 00E0	MEXPFLAG0	Masked exception flag register 0
0x0180 00E4	MEXPFLAG1	Masked exception flag register 1
0x0180 00E8	MEXPFLAG2	Masked exception flag register 2
0x0180 00EC	MEXPFLAG3	Masked exception flag register 3
0x0180 0104	INTMUX1	Interrupt mux register 1
0x0180 0108	INTMUX2	Interrupt mux register 2
0x0180 010C	INTMUX3	Interrupt mux register 3
0x0180 0140	AEGMUX0	Advanced event generator mux register 0
0x0180 0144	AEGMUX1	Advanced event generator mux register 1
0x0180 0180	INTXSTAT	Interrupt exception status
0x0180 0184	INTXCLR	Interrupt exception clear
0x0180 0188	INTDMASK	Dropped interrupt mask register
0x0180 01C0	EVTASRT	Event assert register

6.9 DDR2 Memory Controller

The 32-bit DDR2 memory controller bus of the device is used to interface to JESD79D-2A standard-compliant DDR2 SDRAM devices. The DDR2 external bus interfaces only to DDR2 SDRAM devices; it does not share the bus with any other types of peripherals. The decoupling of DDR2 memories from other devices simplifies board design and provides I/O concurrency from a second external memory interface, EMIFA.

The internal data bus clock frequency and DDR2 bus clock frequency directly affect the maximum throughput of the DDR2 bus. The data rate of the DDR2 bus is equal to the CLKIN2 frequency multiplied by 20. The internal data bus clock frequency of the DDR2 memory controller is fixed at a divide-by-three ratio of the CPU frequency. The maximum DDR2 throughput is determined by the smaller of the two bus frequencies. For example, if the internal data bus frequency is 300 MHz (CPU frequency is 900 MHz) and the DDR2 data rate is 533 MHz (266 MHz clock rate as CLKIN2 frequency is 26.6 MHz), the maximum data rate achievable by the DDR2 memory controller is 2.13 Gbytes/sec.

6.9.1 DDR2 Memory Controller Device-Specific Information

The approach to specifying interface timing for the DDR2 memory bus is different than on other interfaces such as EMIF and HPI. For these other interfaces, the device timing was specified in terms of data manual specifications and I/O buffer information specification (IBIS) models.

For the DDR2 memory bus, the approach is to specify compatible DDR2 devices and provide the printed circuit board (PCB) solution and guidelines directly to the user. Texas Instruments (TI) has performed the simulation and system characterization to be sure all DDR2 interface timings in this solution are met.

The ODT[1:0] pins of the memory controller must be left unconnected. The ODT pins on the DDR2 memory device(s) must be connected to ground.

The DDR2 memory controller on the device supports the following memory topologies:

- A 32-bit wide configuration interfacing to two 16-bit wide DDR2 SDRAM devices.
- A 16-bit wide configuration interfacing to a single 16-bit wide DDR2 SDRAM device.

A race condition may exist when certain masters write data to the DDR2 memory controller. For example, if master A passes a software message via a buffer in external memory and does not wait for indication that the write completes, when master B attempts to read the software message, then the master B read may bypass the master A write and, thus, master B may read stale data and, therefore, receive an incorrect message.

Some master peripherals (e.g., EDMA3 transfer controllers) will always wait for the write to complete before signaling an interrupt to the system, thus avoiding this race condition. For masters that do not have hardware specification of write-read ordering, it may be necessary to specify data ordering via software.

If master A does not wait for indication that a write is complete, it must perform the following workaround:

1. Perform the required write.
2. Perform a dummy write to the DDR2 memory controller module ID and revision register.
3. Perform a dummy read to the DDR2 memory controller module ID and revision register.
4. Indicate to master B that the data is ready to be read after completion of the read in step 3. The completion of the read in step 3 ensures that the previous write was done.

The master peripherals that need to implement this workaround are HPI, PCI, and VLYNQ.

6.9.2 DDR2 Memory Controller Peripheral Registers

Table 6-28. DDR2 Memory Controller Registers⁽¹⁾

HEX ADDRESS RANGE	ACRONYM	REGISTER NAME
0x7800 0000	MIDR	DDR2 Memory Controller Module and Revision Register
0x7800 0004	DMCSTAT	DDR2 Memory Controller Status Register
0x7800 0008	SDCFG	DDR2 Memory Controller SDRAM Configuration Register
0x7800 000C	SDRFC	DDR2 Memory Controller SDRAM Refresh Control Register
0x7800 0010	SDTIM1	DDR2 Memory Controller SDRAM Timing 1 Register
0x7800 0014	SDTIM2	DDR2 Memory Controller SDRAM Timing 2 Register
0x7800 0018	-	Reserved
0x7800 0020	BPRIO	DDR2 Memory Controller Burst Priority Register
0x7800 0024 - 0x7800 004C	-	Reserved
0x7800 0050 - 0x7800 0078	-	Reserved
0x7800 007C - 0x7800 00BC	-	Reserved
0x7800 00C0 - 0x7800 00E0	-	Reserved
0x7800 00E4	DMCCTL	DDR2 Memory Controller Control Register
0x7800 00E8 - 0x7800 00FC	-	Reserved
0x7800 0100 - 0x7FFF FFFF	-	Reserved

(1) For details about the DDR2 registers and their modes, see the *TMS320DM647/DM648 DSP DDR2 Memory Controller (DDR2) User's Guide* (literature number [SPRUEK5](#)).

6.9.3 DDR2 Interface

This section provides the timing information for the DDR2 interface as a PCB design and manufacturing specification. The design rules constrain PCB trace length, PCB trace skew, signal integrity, cross-talk, and signal timing. These rules, when followed, result in a reliable DDR2 memory system without the need for a complex timing closure process. For more information regarding guidelines for using this DDR2 specification, *Understanding TI's PCB Routing Rule-Based DDR2 Timing Specification* ([SPRAAV0](#)).

6.9.3.1 DDR2 Interface Schematic

[Figure 6-11](#) shows the DDR2 interface schematic for a x32 DDR2 memory system. The x16 DDR2 system schematic shown in [Figure 6-12](#) is identical except that the high word DDR2 device is deleted.

6.9.3.2 Compatible JEDEC DDR2 Devices

[Table 6-29](#) shows the parameters of the JEDEC DDR2 devices that are compatible with this interface. Generally, the DDR2 interface is compatible with x16 DDR2-533 speed grade DDR2 devices.

Table 6-29. Compatible JEDEC DDR2 Devices

NO.	PARAMETER	MIN	MAX	UNIT
1	JEDEC DDR2 Device Speed Grade ⁽¹⁾	DDR2-533		
2	JEDEC DDR2 Device Bit Width	x16	x16	Bits
3	JEDEC DDR2 Device Count ⁽²⁾	1	2	Devices
4	JEDEC DDR2 Device Ball Count ⁽³⁾	84	92	Balls

(1) Higher DDR2 speed grades are supported due to inherent JEDEC DDR2 backwards compatibility.

(2) One DDR2 device is used for 16-bit DDR2 memory system. Two DDR2 devices are used for 32-bit DDR2 memory system.

(3) 92 ball devices retained for legacy support. New designs will migrate to 84 ball DDR2 devices. Electrically, the 92 and 84 ball DDR2 devices are the same.

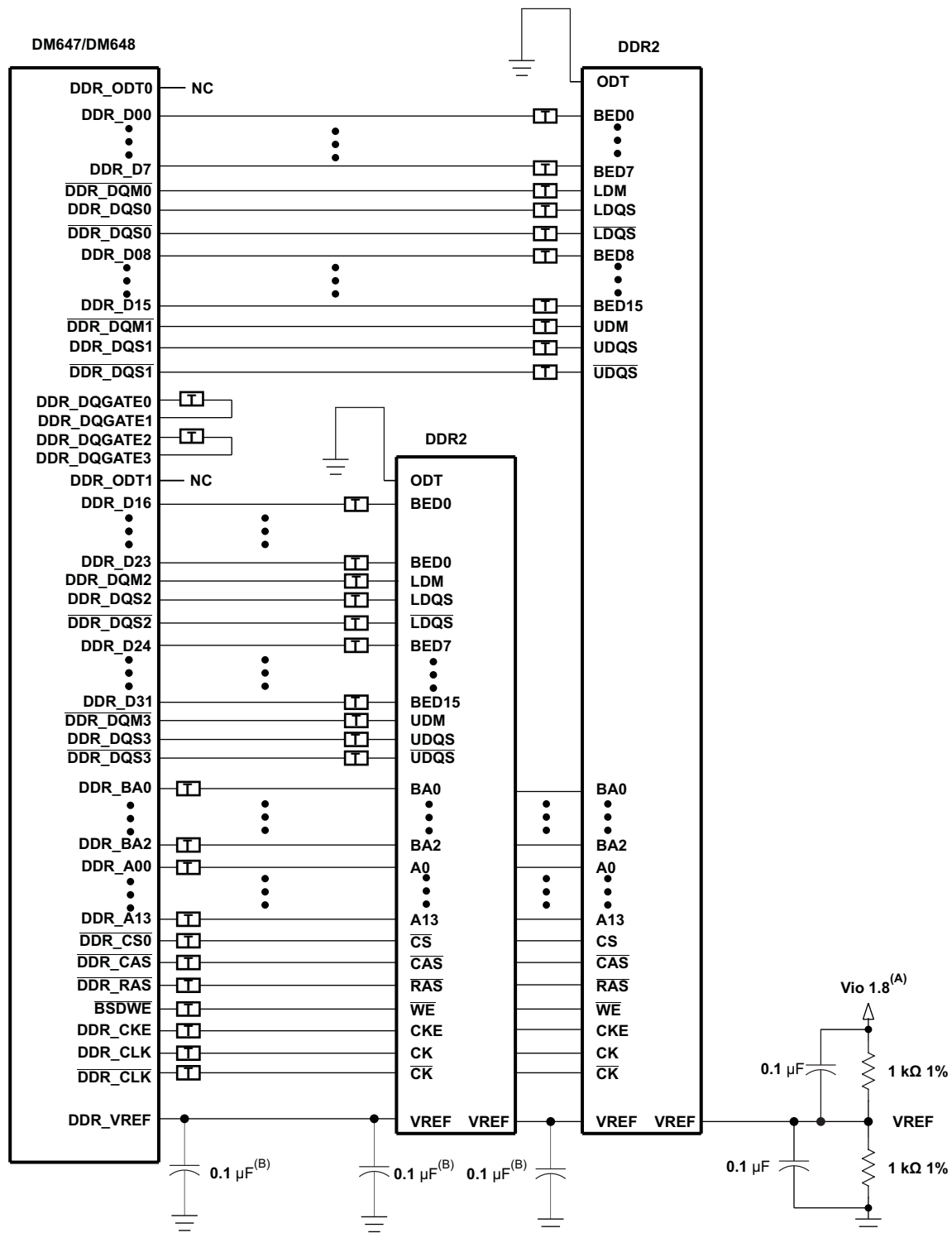

 Terminator, if desired. See terminator comments.

- A. DM648 is shown in this figure as an example of the device and represents the entire set of devices that include: DM647/DM648.
- B. V_{IO} 1.8 is the power supply for the DDR2 memory interface.
- C. One of these capacitors can be eliminated if the divider and its capacitors are placed near a device VREF pin.

Figure 6-11. 32-Bit DDR2 High-Level Schematic

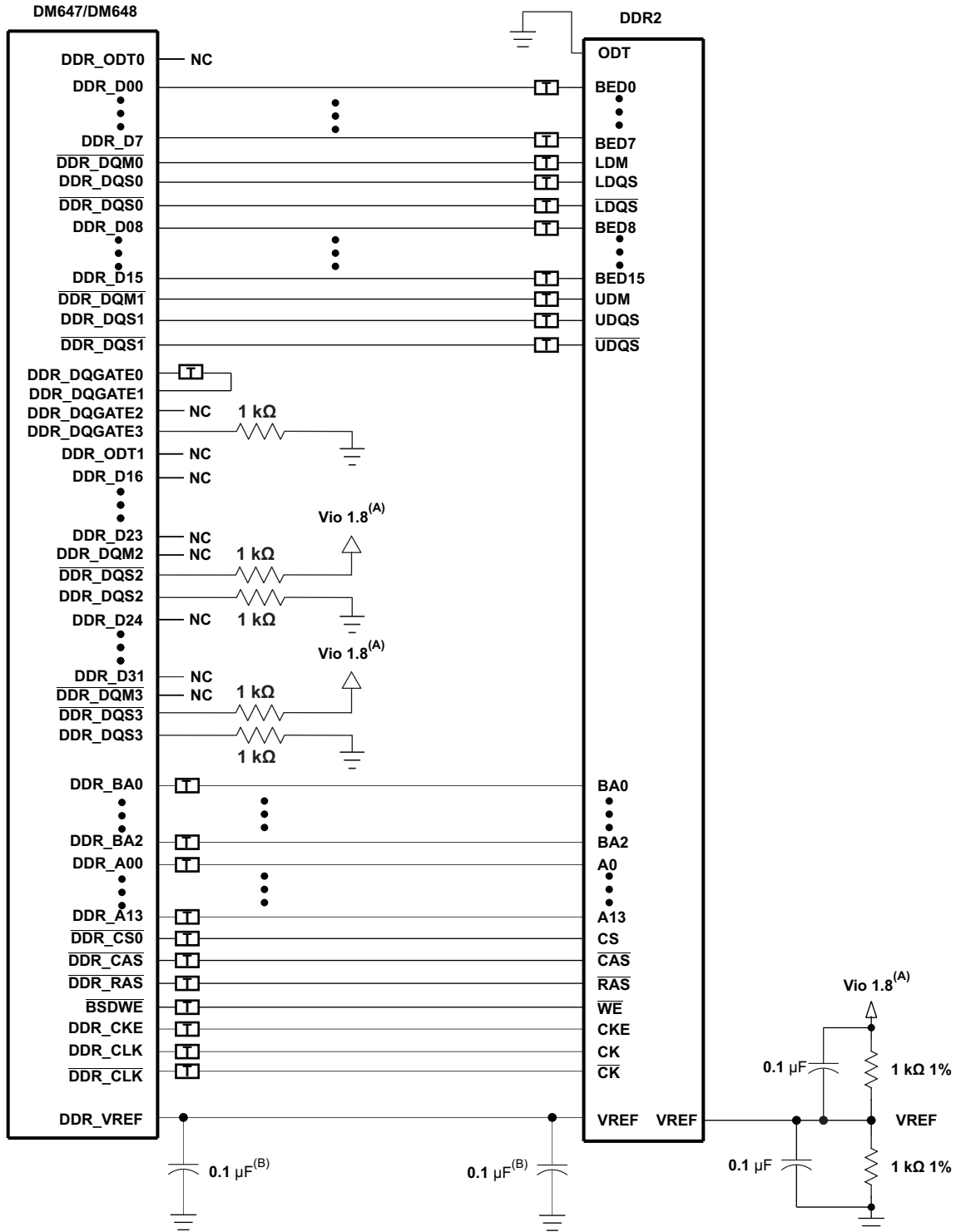

T Terminator, if desired. See terminator comments.

- A. DM648 is shown in this figure as an example of the device and represents the entire set of devices that include: DM647/DM648.
- B. One of these capacitors can be eliminated if the divider and its capacitors are placed near a device VREF pin.
- C. Vio 1.8 is the power supply for the DDR2 memory interface.

Figure 6-12. 16-Bit DDR2 High-Level Schematic

6.9.3.3 PCB Stackup

The minimum stackup required for routing the device is a six-layer stack as shown in [Table 6-30](#). Additional layers may be added to the PCB stack up to accommodate other circuitry or to reduce the size of the PCB footprint.

Table 6-30. Minimum PCB Stack Up

LAYER	TYPE	DESCRIPTION
1	Signal	Top routing mostly horizontal
2	Plane	Ground
3	Plane	Power
4	Signal	Internal routing
5	Plane	Ground
6	Signal	Bottom routing mostly vertical

Complete stack up specifications are provided in [Table 6-31](#).

Table 6-31. PCB Stack Up Specifications

NO.	PARAMETER	MIN	TYP	MAX	UNIT
1	PCB Routing/Plane Layers	6			
2	Signal Routing Layers	3			
3	Full ground layers under DDR2 routing Region	2			
4	Number of ground plane cuts allowed within DDR routing region			0	
5	Number of ground reference planes required for each DDR2 routing layer	1			
6	Number of layers between DDR2 routing layer and reference ground plane			0	
7	PCB Routing Feature Size		4		Mils
8	PCB Trace Width w		4		Mils
8	PCB BGA escape via pad size		18		Mils
9	PCB BGA escape via hole size		8		Mils
10	DSP Device BGA pad size ⁽¹⁾				
11	DDR2 Device BGA pad size ⁽²⁾				
12	Single Ended Impedance, Z ₀	50		75	Ω
13	Impedance Control ⁽³⁾	Z-5	Z	Z+5	Ω

(1) See the *Flip Chip Ball Grid Array Package Reference Guide* ([SPRU811](#)) for DSP device BGA pad size.

(2) See the DDR2 device manufacturer documentation for the DDR2 device BGA pad size.

(3) Z is the nominal singled ended impedance selected for the PCB specified by item 12.

6.9.3.4 Placement

[Figure 6-13](#) shows the required placement for the device as well as the DDR2 devices. The dimensions for [Figure 6-13](#) are defined in [Table 6-32](#). The placement does not restrict the side of the PCB where the devices are mounted. The purpose of the placement is to limit the maximum trace lengths and allow for proper routing space. For 16-bit DDR memory systems, the high word DDR2 device is omitted from the placement.

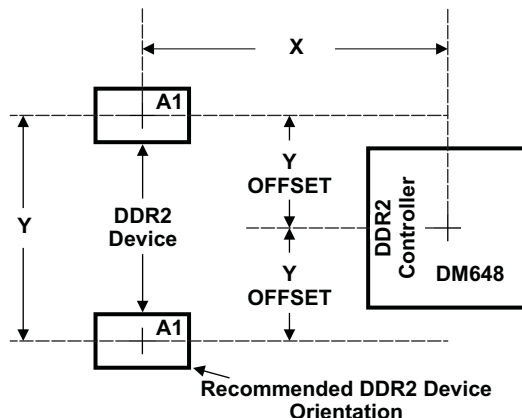

- A. DM648 is shown in this figure as an example of the device and represents the entire set of devices that include: DM647/DM648.

Figure 6-13. DDR2 Device Placement

Table 6-32. Placement Specifications

NO.	PARAMETER	MIN	MAX	UNIT
1	X ⁽¹⁾ (2)		1660	Mils
2	Y ⁽¹⁾ (2)		1280	Mils
3	Y Offset ⁽¹⁾ (2) (3)		650	Mils
4	DDR2 Keepout Region ⁽⁴⁾			
5	Clearance from non-DDR2 signal to DDR2 Keepout Region ⁽⁵⁾	4		w

- (1) See Figure 6-11 for dimension definitions.
 (2) Measurements from center of DSP device to center of DDR2 device.
 (3) For 16-bit memory systems, it is recommended that Y Offset be as small as possible.
 (4) DDR2 Keepout region to encompass entire DDR2 routing area
 (5) Non-DDR2 signals allowed within DDR2 keepout region provided they are separated from DDR2 routing layers by a ground plane.

6.9.3.5 DDR2 Keep Out Region

The region of the PCB used for the DDR2 circuitry must be isolated from other signals. The DDR2 keep out region is defined for this purpose and is shown in Figure 6-14. The size of this region varies with the placement and DDR routing. Additional clearances required for the keep out region are shown in Table 6-32.

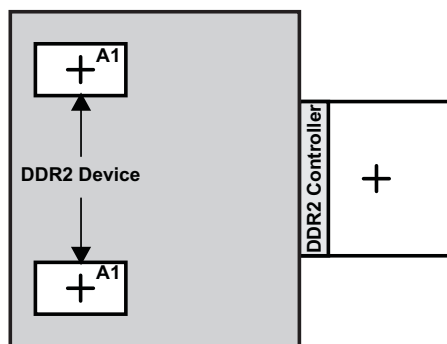

Figure 6-14. DDR2 Keepout Region

NOTE

The region (see [Figure 6-14](#)) should encompass all DDR2 circuitry and varies depending on placement. Non-DDR2 signals should not be routed on the DDR signal layers within the DDR2 keep out region. Non-DDR2 signals may be routed in the region provided they are routed on layers separated from DDR2 signal layers by a ground layer. No breaks should be allowed in the reference ground layers in this region. In addition, the 1.8-V power plane should cover the entire keep out region.

6.9.3.6 Bulk Bypass Capacitors

Bulk bypass capacitors are required for moderate speed bypassing of the DDR2 and other circuitry. [Table 6-33](#) contains the minimum numbers and capacitance required for the bulk bypass capacitors. This table covers only the bypass needs of the DSP and DDR2 interfaces. Additional bulk bypass capacitance may be needed for other circuitry.

Table 6-33. Bulk Bypass Capacitors

NO.	PARAMETER	MIN	MAX	UNIT
1	DV _{DD18} Bulk Bypass Capacitor Count ⁽¹⁾	3		Devices
2	DV _{DD18} Bulk Bypass Total Capacitance	30		μF
3	DDR#1 Bulk Bypass Capacitor Count ⁽²⁾	1		Devices
4	DDR#1 Bulk Bypass Total Capacitance	10		μF
5	DDR#2 Bulk Bypass Capacitor Count ^{(2) (3)}	1		Devices
6	DDR#2 Bulk Bypass Total Capacitance ⁽³⁾	10		μF

- (1) These devices should be placed near the device they are bypassing, but preference should be given to the placement of the high-speed (HS) bypass caps.
- (2) These devices should be placed near the device they are bypassing, but preference should be given to the placement of the high-speed (HS) bypass caps.
- (3) Only used on 32-bit wide DDR2 memory systems

6.9.3.7 High-Speed Bypass Capacitors

High-Speed (HS) bypass capacitors are critical for proper DDR2 interface operation. It is particularly important to minimize the parasitic series inductance of the HS bypass cap, DSP/DDR power, and DSP/DDR ground connections. [Table 6-34](#) contains the specification for the HS bypass capacitors as well as for the power connections on the PCB.

6.9.3.8 Net Classes

[Table 6-35](#) lists the clock net classes for the DDR2 interface. [Table 6-36](#) lists the signal net classes, and associated clock net classes, for the signals in the DDR2 interface. These net classes are used for the termination and routing rules that follow.

Table 6-34. High-Speed Bypass Capacitors

NO.	PARAMETER	MIN	MAX	UNIT
1	HS Bypass Capacitor Package Size ⁽¹⁾		0402	10 Mils
2	Distance from HS bypass capacitor to device being bypassed		250	Mils
3	Number of connection vias for each HS bypass capacitor ⁽²⁾	2		Vias
4	Trace length from bypass capacitor contact to connection via	1	30	Mils
5	Number of connection vias for each DDR2 device power or ground balls	1		Vias
6	Trace length from DDR2 device power ball to connection via		35	Mils
7	DV _{DD18} HS Bypass Capacitor Count ⁽³⁾	20		Devices
8	DV _{DD18} HS Bypass Capacitor Total Capacitance	1.2		μF

- (1) L x W, 10 mil units (i.e., a 0402 is a 40 x 20 mil surface mount capacitor)
- (2) An additional HS bypass capacitor can share the connection vias only if it is mounted on the opposite side of the board.
- (3) These devices should be placed as close as possible to the device being bypassed.

Table 6-34. High-Speed Bypass Capacitors (continued)

NO.	PARAMETER	MIN	MAX	UNIT
9	DDR#1 HS Bypass Capacitor Count ⁽³⁾	8		Devices
10	DDR#1 HS Bypass Capacitor Total Capacitance	0.4		μF
11	DDR#2 HS Bypass Capacitor Count ^{(3) (4)}	8		Devices
12	DDR#2 HS Bypass Capacitor Total Capacitance ⁽⁴⁾	0.4		μF

(4) Only used on 32-bit wide DDR2 memory systems

Table 6-35. Clock Net Class Definitions

CLOCK NET CLASS	DSP PIN NAMES
CK	DDR_CLK/ $\overline{\text{DDR_CLK}}$
DQS0	DDR_DQS0/ $\overline{\text{DDR_DQS0}}$
DQS1	DDR_DQS1/ $\overline{\text{DDR_DQS1}}$
DQS2 ⁽¹⁾	DDR_DQS2/ $\overline{\text{DDR_DQS2}}$
DQS3 ⁽¹⁾	DDR_DQS3/ $\overline{\text{DDR_DQS3}}$

(1) Only used on 32-bit wide DDR2 memory systems.

Table 6-36. Signal Net Class Definitions

CLOCK NET CLASS	ASSOCIATED CLOCK NET CLASS	DSP PIN NAMES
ADDR_CTRL	CK	DDR_BA[2:0], DDR_A[13:0], $\overline{\text{DDR_CS}}$, $\overline{\text{DDR_CAS}}$, $\overline{\text{DDR_RAS}}$, $\overline{\text{DDR_WE}}$, $\overline{\text{DDR_CKE}}$
DQ0	DQS0	DDR_D[7:0], DDR_DQM0
DQ1	DQS1	DDR_D[15:8], DDR_DQM1
DQ2 ⁽¹⁾	DQS2	DDR_D[23:16], DDR_DQM2
DQ3 ⁽¹⁾	DQS3	DDR_D[31:24], DDR_DQM3
DQGATEL	CK, DQS0, DQS1	DDR_DQGATE0, DDR_DQGATE1
DQGATEH ⁽¹⁾	CK, DQS2, DQS3	DDR_DQGATE2, DDR_DQGATE3

(1) Only used on 32-bit wide DDR2 memory systems.

6.9.3.9 DDR2 Signal Termination

No terminations of any kind are required in order to meet signal integrity and overshoot requirements. Serial terminators are permitted, if desired, to reduce EMI risk; however, serial terminations are the only type permitted. [Table 6-37](#) shows the specifications for the series terminators.

Table 6-37. DDR2 Signal Terminations

NO.	PARAMETER	MIN	TYP	MAX	UNIT
1	CK Net Class ⁽¹⁾	0		10	Ω
2	ADDR_CTRL Net Class ^{(1) (2) (3)}	0	22	Z ₀	Ω
3	Data Byte Net Classes (DQS0-DQS3, DQ0-DQ3) ^{(1) (2) (3) (4)}	0	22	Z ₀	Ω
4	DQGATE Net Classes (DQGATEL, DQGATEH) ^{(1) (2) (3)}	0	10	Z ₀	Ω

(1) Only series termination is permitted, parallel or SST specifically disallowed.

(2) Terminator values larger than typical only recommended to address EMI issues.

(3) Termination value should be uniform across net class.

(4) When no termination is used on data lines (0 Ωs), the DDR2 devices must be programmed to operate in 60% strength mode.

6.9.3.10 VREF Routing

VREF is used as a reference by the input buffers of the DDR2 memories as well as the device's. VREF is intended to be 1/2 the DDR2 power supply voltage and should be created using a resistive divider as shown in Figure 6-11. Other methods of creating VREF are not recommended. Figure 6-15 shows the layout guidelines for VREF.

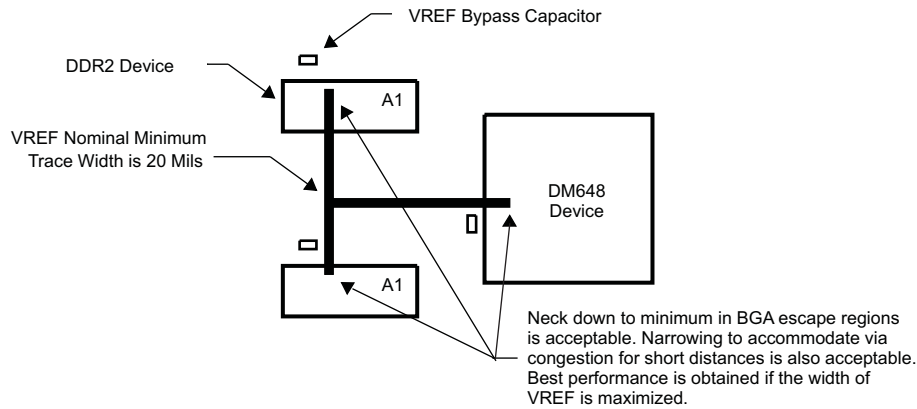

- A. DM648 is shown in this figure as an example of the device and represents the entire set of devices that include: DM647/DM648.

Figure 6-15. VREF Routing and Topology

6.9.3.11 DDR2 CK and ADDR_CTRL Routing

Figure 6-16 shows the topology of the routing for the CK and ADDR_CTRL net classes. The route is a balanced T as it is intended that the length of segments B and C be equal. In addition, the length of A should be maximized.

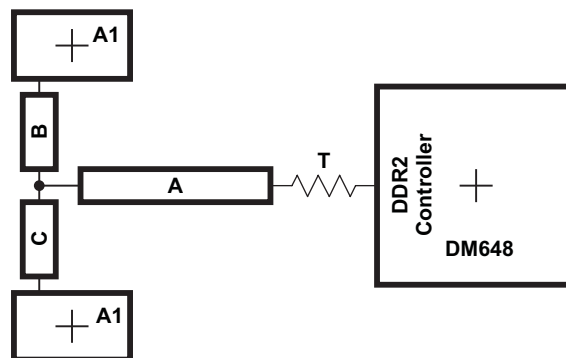

- A. DM648 is shown in this figure as an example of the device and represents the entire set of devices that include: DM647/DM648.

Figure 6-16. CK and ADDR_CTRL Routing and Topology

Table 6-38. CK and ADDR_CTRL Routing Specification⁽¹⁾

NO	PARAMETER	MIN	TYP	MAX	UNIT
1	Center to center CK- $\overline{\text{CK}}$ spacing			2w	
2	CK A to B/A to C Skew Length Mismatch ⁽¹⁾			25	Mils
3	CK B to C Skew Length Mismatch			25	Mils
4	Center to center CK to other DDR2 trace spacing ⁽²⁾	4w			
5	CK/ADDR_CTRL nominal trace length ⁽³⁾	CACLM-50	CACLM	CACLM+50	Mils
6	ADDR_CTRL to CK Skew Length Mismatch			100	Mils
7	ADDR_CTRL to ADDR_CTRL Skew Length Mismatch			100	Mils
8	Center to center ADDR_CTRL to other DDR2 trace spacing ⁽²⁾	4w			
9	Center to center ADDR_CTRL to other ADDR_CTRL trace spacing ⁽²⁾	3w			
10	ADDR_CTRL A to B/A to C Skew Length Mismatch ⁽¹⁾			100	Mils
11	ADDR_CTRL B to C Skew Length Mismatch			100	Mils

- (1) Series terminator, if used, should be located closest to DSP.
- (2) Center to center spacing is allowed to fall to minimum (w) for up to 500 mils of routed length to accommodate BGA escape and routing congestion.
- (3) CACLM is the longest Manhattan distance of the CK and ADDR_CTRL net classes.

Figure 6-17 shows the topology and routing for the DQS and DQ net classes; the routes are point to point. Skew matching across bytes is not needed nor recommended.

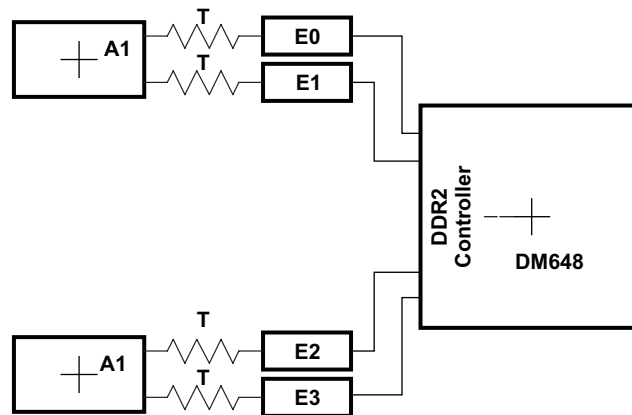

- A. DM648 is shown in this figure as an example of the device and represents the entire set of devices that include: DM647/DM648.

Figure 6-17. DQS and DQ Routing and Topology

Table 6-39. DQS and DQ Routing Specification⁽¹⁾

NO.	PARAMETER	MIN	TYP	MAX	UNIT
1	Center to center DQS- $\overline{\text{DQS}}$ spacing			2 w	
2	DQS E Skew Length Mismatch			25	Mils
3	Center to center DQS to other DDR2 trace spacing ⁽²⁾	4 w			
4	DQS/DQ nominal trace length ^{(1) (3) (4) (5)}	DQLM-50	DQLM	DQLM+50	Mils
5	DQ to DQS Skew Length Mismatch ^{(3) (4) (5)}			100	Mils
6	DQ to DQ Skew Length Mismatch ^{(3) (4) (5)}			100	Mils

- (1) Series terminator, if used, should be located closest to DDR.
- (2) Center to center spacing is allowed to fall to minimum (w) for up to 500 mils of routed length to accommodate BGA escape and routing congestion.
- (3) A 16-bit DDR memory system has two sets of data net classes, one for data byte 0, and one for data byte 1, each with an associated DQS (2 DQSs).
- (4) A 32-bit DDR memory system will have four sets of data net classes, one each for data bytes 0 through 3, and each associated with a DQS (4 DQSs).
- (5) There is no need and it is not recommended to skew match across data bytes, i.e., from DQS0 and data byte 0 to DQS1 and data byte 1.

Table 6-39. DQS and DQ Routing Specification ⁽¹⁾ (continued)

NO.	PARAMETER	MIN	TYP	MAX	UNIT
7	Center to center DQ to other DDR2 trace spacing ⁽²⁾ ⁽⁶⁾	4 w			
8	Center to Center DQ to other DQ trace spacing ⁽⁷⁾ ⁽²⁾	3w			
9	DQ/DQS E Skew Length Mismatch ⁽³⁾ ⁽⁴⁾ ⁽⁵⁾			100	Mils

(6) DQs from other DQS domains are considered *other DDR2 trace*.

(7) DQLM is the longest Manhattan distance of each of the DQS and DQ net classes.

Figure 6-18 shows the routing for the DQGATE net classes. Table 6-40 contains the routing specification.

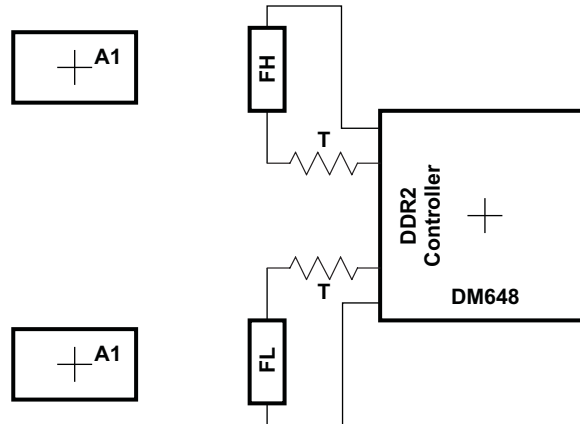

A. DM648 is shown in this figure as an example of the device and represents the entire set of devices that include: DM647/DM648.

Figure 6-18. DQGATE Routing

Table 6-40. DQGATE Routing Specification

NO.	PARAMETER	MIN	TYP	MAX	UNIT
1	DQGATEL Length F ⁽¹⁾		CKB0B1		
2	DQGATEH Length F ⁽²⁾ ⁽³⁾		CKB2B3		
3	Center to center DQGATE to any other trace spacing	4 w			
4	DQS/DQ nominal trace length	DQLM - 50	DQLM	DQLM + 50	Mils
5	DQGATEL Skew ⁽⁴⁾			100	Mils
6	DQGATEH Skew ⁽⁵⁾ ⁽³⁾			100	Mils

(1) CKB0B1 is the sum of the length of the CK net plus the average length of the DQS0 and DQS1 nets.

(2) CKB2B3 is the sum of the length of the CK net plus the average length of the DQS2 and DQS3 nets.

(3) Only used on 32-bit-wide DDR2 memory systems.

(4) Skew from CKB0B1

(5) Skew from CKB2B3

6.10 External Memory Interface A (EMIFA)

The EMIFA can interface to a variety of external devices or ASICs, including:

- Pipelined and flow-through synchronous-burst SRAM (SBSRAM)
- ZBT (zero bus turnaround) SRAM and late write SRAM
- Synchronous FIFOs
- Asynchronous memory, including SRAM, ROM, and Flash

6.10.1 EMIFA Device-Specific Information

Timing analysis must be done to verify all ac timing requirements are met. TI recommends utilizing I/O buffer information specification (IBIS) to analyze all ac timing.

To properly use IBIS models to attain accurate timing analysis for a given system, see the *Using IBIS Models for Timing Analysis Application Report* (literature number [SPRA839](#)).

To maintain signal integrity, serial termination resistors should be inserted into all EMIFA output signal lines.

A race condition may exist when certain masters write data to the EMIFA. For example, if master A passes a software message via a buffer in external memory and does not wait for indication that the write completes, when master B attempts to read the software message, then the master B read may bypass the master A write and, thus, master B may read stale data and, therefore, receive an incorrect message.

Some master peripherals (e.g., EDMA3 transfer controllers) will always wait for the write to complete before signaling an interrupt to the system, thus avoiding this race condition. For masters that do not have hardware specification of write-read ordering, it may be necessary to specify data ordering via software.

If master A does not wait for indication that a write is complete, it must perform the following workaround:

1. Perform the required write.
2. Perform a dummy write to the EMIFA module ID and revision register.
3. Perform a dummy read to the EMIFA module ID and revision register.
4. Indicate to master B that the data is ready to be read after completion of the read in step 3. The completion of the read in step 3 ensures that the previous write was done.

6.10.2 EMIFA Peripheral Register Description(s)

For more information on the EMIF registers shown in [Table 6-41](#), see *TMS320DM647/DM648 DSP External Memory Interface (EMIF) User's Guide* (literature number [SPRUEK6](#)).

Table 6-41. EMIFA Registers

HEX ADDRESS RANGE	ACRONYM	REGISTER NAME
0x7000 0000	MIDR	Module ID and Revision Register
0x7000 0004	STAT	Status Register
0x7000 0008	-	Reserved
0x7000 000C - 0x7000 001C	-	Reserved
0x7000 0020	BPRIO	Burst Priority Register
0x7000 0024 - 0x7000 004C	-	Reserved
0x7000 0050 - 0x7000 007C	-	Reserved
0x7000 0080	CE2CFG	EMIFA CE2 Configuration Register
0x7000 0084	CE3CFG	EMIFA CE3 Configuration Register
0x7000 0088	-	Reserved
0x7000 008C	-	Reserved
0x7000 0090 - 0x7000 009C	-	Reserved
0x7000 00A0	AWCC	EMIFA Async Wait Cycle Configuration Register

Table 6-41. EMIFA Registers (continued)

HEX ADDRESS RANGE	ACRONYM	REGISTER NAME
0x7000 00A4 - 0x7000 00BC	-	Reserved
0x7000 00C0	INTRAW	EMIFA Interrupt RAW Register
0x7000 00C4	INTMSK	EMIFA Interrupt Masked Register
0x7000 00C8	INTMSKSET	EMIFA Interrupt Mask Set Register
0x7000 00CC	INTMSKCLR	EMIFA Interrupt Mask Clear Register
0x7000 00D0 - 0x7000 00DC	-	Reserved
0x7000 00E0 - 0x77FF FFFF	-	Reserved

6.10.3 EMIFA Electrical Data/Timing

Table 6-42. Timing Requirements for AECLKIN for EMIFA^{(1) (2)} (see Figure 6-19)

NO.			720, 800, 900, 1100		UNIT
			MIN	MAX	
1	$t_{c(EKI)}$	Cycle time, AECLKIN	6 ⁽³⁾	16P ⁽⁴⁾	ns
2	$t_{w(EKIH)}$	Pulse duration, AECLKIN high	2.7		ns
3	$t_{w(EKIL)}$	Pulse duration, AECLKIN low	2.7		ns
4	$t_t(EKI)$	Transition time, AECLKIN		2	ns
5	$t_j(EKI)$	Period Jitter, AECLKIN		0.02E ⁽⁵⁾	ns

- (1) The reference points for the rise and fall transitions are measured at V_{IL} MAX and V_{IH} MIN.
- (2) E = the EMIF input clock (AECLKIN or SYSCLK4/2) period in ns for EMIFA.
- (3) Minimum AECLKIN cycle times *must* be met, even when AECLKIN is generated by an internal clock source. Minimum AECLKIN times are based on internal logic speed; the maximum useable speed of the EMIF may be lower due to AC timing requirements.
- (4) P is $P = 1/\text{CPU clock frequency}$ in ns.
- (5) This timing applies only when AECLKIN is used for EMIFA.

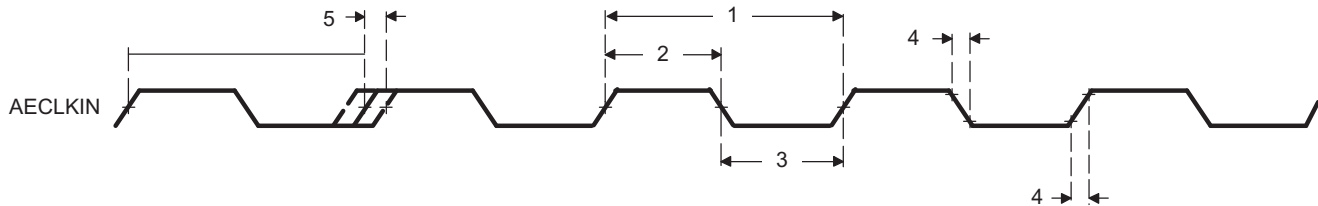
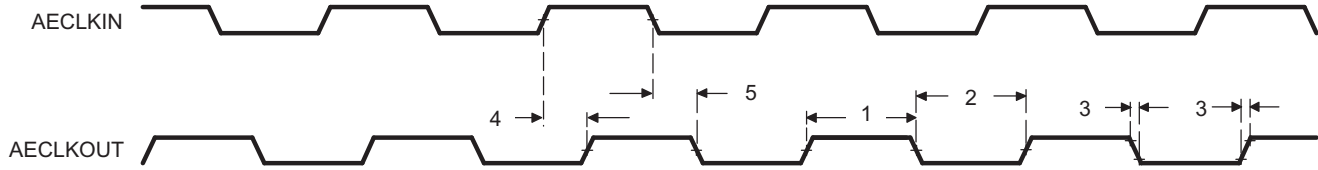

Figure 6-19. AECLKIN Timing for EMIFA

Table 6-43. Switching Characteristics Over Recommended Operating Conditions for AECLKOUT for the EMIFA Module^{(1) (2) (3)} (see Figure 6-20)

NO.	PARAMETER	720, 800, 900, 1100		UNIT
		MIN	MAX	
1	$t_{c(EKO)}$	E - 0.7	E + 0.7	ns
2	$t_{w(EKOH)}$	EH - 0.7	EH + 0.7	ns
3	$t_{w(EKOL)}$	EL - 0.7	EL + 0.7	ns
4	$t_t(EKO)$		1	ns
5	$t_d(EKIH-EKOH)$	1	8	ns
6	$t_d(EKIL-EKOL)$	1	8	ns

- (1) E = the EMIF input clock (AECLKIN or SYSCLK4/2) period in ns for EMIFA.
- (2) The reference points for the rise and fall transitions are measured at V_{OL} MAX and V_{OH} MIN.
- (3) EH is the high period of E (EMIF input clock period) in ns and EL is the low period of E (EMIF input clock period) in ns for EMIFA.



- A. E = the EMIF input clock (AECLKIN or SYSCLK4/2) period in ns for EMIFA.
- B. The reference points for the rise and fall transitions are measured at $V_{OL\ MAX}$ and $V_{OH\ MIN}$.
- C. EH is the high period of E (EMIF input clock period) in ns and EL is the low period of E (EMIF input clock period) in ns for EMIFA.

Figure 6-20. AECLKOUT Timing for the EMIFA Module

6.10.3.1 Asynchronous Memory Timing

Table 6-44. Timing Requirements for Asynchronous Memory Cycles for EMIFA Module^{(1) (2) (3)}
(see Figure 6-21 and Figure 6-22)

NO.	PARAMETER	720, 800, 900, 1100		UNIT
		MIN	MAX	
3	$t_{su}(EDV-A\ OE H)$ Setup time, AEDx valid before $\overline{AAOE}/ASOE$ high	6.5		ns
4	$t_h(AOE H-EDV)$ Hold time, AEDx valid after $\overline{AAOE}/ASOE$ high	0		ns
5	$t_{su}(ARDY-EKOH)$ Setup time, AARDY valid before AECLKOUT low	1		ns
6	$t_h(EKOH-ARDY)$ Hold time, AARDY valid after AECLKOUT low	2		ns
7	$t_w(ARDY)$ Pulse width, AARDY assertion and deassertion	2E + 5		ns
8	$t_d(ARDY-HOLD)$ Delay time, from AARDY sampled deasserted on AECLKOUT falling to beginning of programmed hold period	4E		ns
9	$t_{su}(ARDY-HOLD)$ Setup time, before end of programmed strobe period by which AARDY should be asserted in order to insert extended strobe wait states.	2E		ns

- (1) E = AECLKOUT period in ns for EMIFA
- (2) To specify data setup time, simply program the strobe width wide enough.
- (3) AARDY is internally synchronized. To use AARDY as an asynchronous input, the pulse width of the AARDY signal should be at least 2E to specify setup and hold time is met.

Table 6-45. Switching Characteristics Over Recommended Operating Conditions for Asynchronous Memory Cycles for EMIFA Module^{(1) (2) (3)} (see Figure 6-21 and Figure 6-22)

NO.	PARAMETER	720, 800, 900, 1100		UNIT
		MIN	MAX	
1	$t_{osu}(SELV-AOEL)$ Output setup time, select signals valid to $\overline{AAOE}/ASOE$ low	RS x E - 1.5		ns
2	$t_{oh}(AOEH-SELIV)$ Output hold time, $\overline{AAOE}/ASOE$ high to select signals invalid	RS x E - 1.9		ns
10	$t_d(EKOH-AOEV)$ Delay time, AECLKOUT high to $\overline{AAOE}/ASOE$ valid	1	7.28	ns
11	$t_{osu}(SELV-AWEL)$ Output setup time, select signals valid to $\overline{AAWE}/ASWE$ low	WS x E - 1.7		ns
12	$t_{oh}(AWEH-SELIV)$ Output hold time, $\overline{AAWE}/ASWE$ high to select signals invalid	WH x E - 1.8		ns
13	$t_d(EKOH-AWEV)$ Delay time, AECLKOUT high to $\overline{AAWE}/ASWE$ valid	1.3	7.1	ns

- (1) E = AECLKOUT period in ns for EMIFA
- (2) RS = Read setup, RST = Read strobe, RH = Read hold, WS = Write setup, WST = Write strobe, WH = Write hold. These parameters are programmed via the EMIFA CE Configuration registers (CEnCFG).
- (3) Select signals for EMIFA include: \overline{ACEX} , $\overline{ABE}[1:0]$, $\overline{AEA}[23:0]$, $\overline{ABA}[1:0]$; and for EMIFA writes, also include \overline{ARW} , $\overline{AED}[15:0]$.

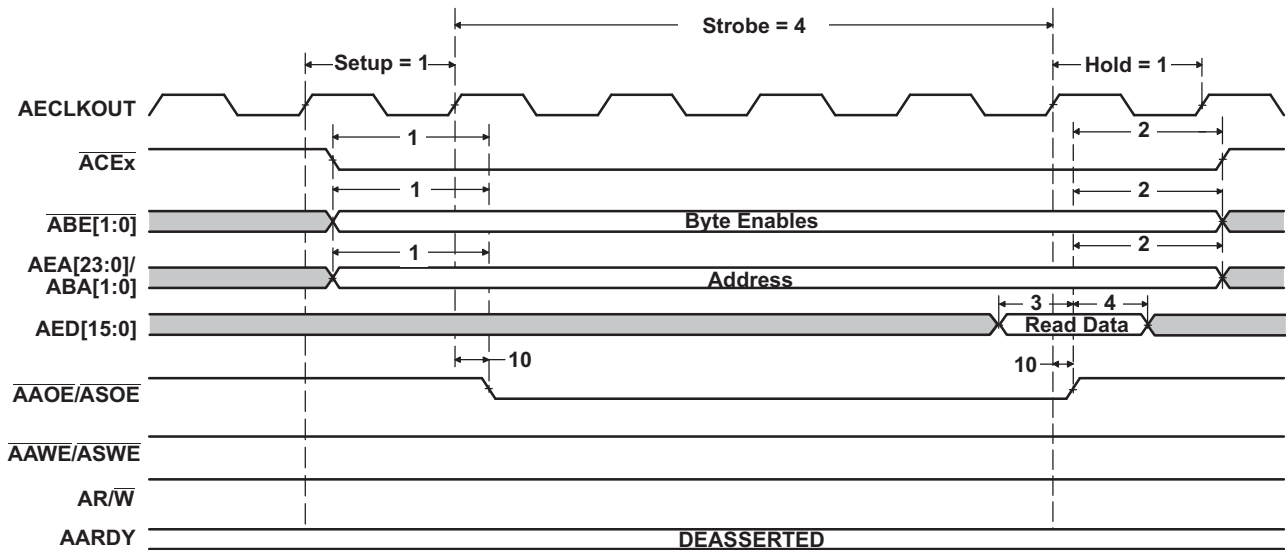

- A. $\overline{AAOE}/\overline{ASOE}$ and $\overline{AAWE}/\overline{ASWE}$ operate as $\overline{AAOE}/\overline{ASOE}$ (identified under select signals) and $\overline{AAWE}/\overline{ASWE}$, respectively, during asynchronous memory accesses.
- B. Polarity of the AARDY signal is programmable through the AP field of the EMIFA Async Wait Cycle Configuration register (AWCC).

Figure 6-21. Asynchronous Memory Read Timing for EMIFA

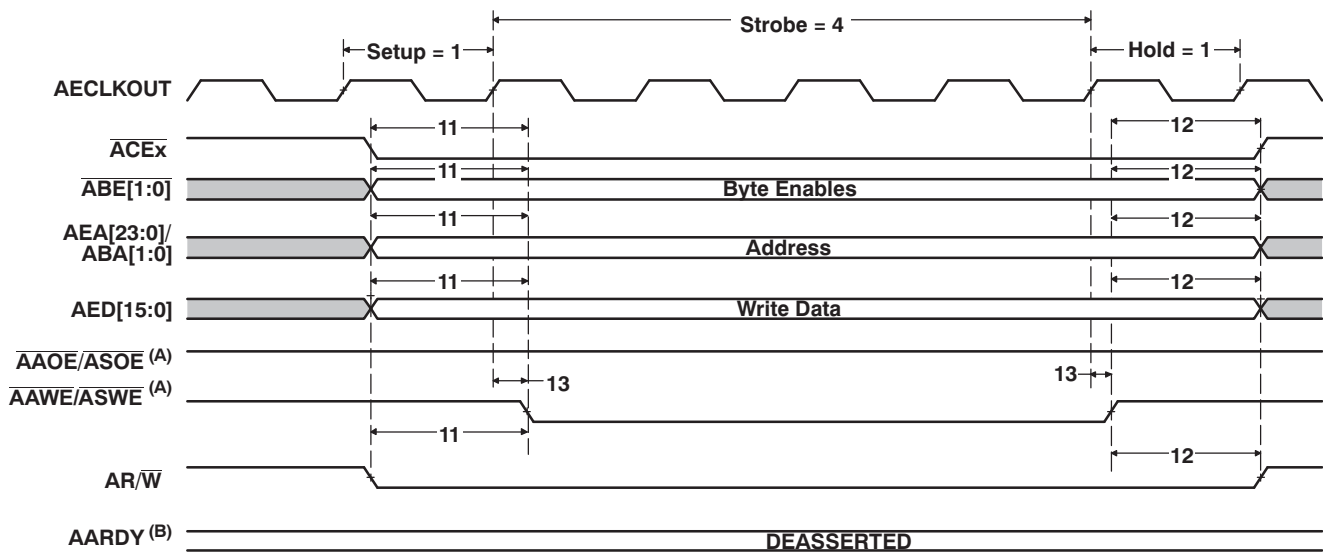

- A. $\overline{AAOE}/\overline{ASOE}$ and $\overline{AAWE}/\overline{ASWE}$ operate as $\overline{AAOE}/\overline{ASOE}$ and $\overline{AAWE}/\overline{ASWE}$ (identified under select signals) during asynchronous memory accesses.
- B. Polarity of the AARDY signal is programmable through the AP field of the EMIFA Async Wait Cycle Configuration register (AWCC).

Figure 6-22. Asynchronous Memory Write Timing for EMIFA

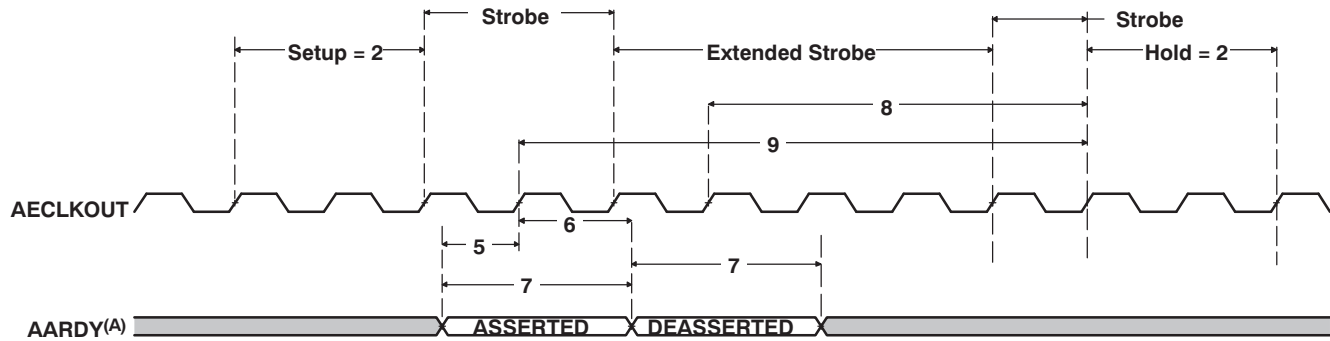

A. Polarity of the AARDY signal is programmable through the AP field of the EMIFA Async Wait Cycle Configuration register (AWCC).

Figure 6-23. AARDY Timing

6.10.3.2 Programmable Synchronous Interface Timing

Table 6-46. Timing Requirements for Programmable Synchronous Interface Cycles for EMIFA Module (see Figure 6-24)

NO.		720, 800, 900, 1100		UNIT
		MIN	MAX	
6	$t_{su}(EDV-EKOH)$ Setup time, read AEDx valid before AECLKOUT high	2		ns
7	$t_h(EKOH-EDV)$ Hold time, read AEDx valid after AECLKOUT high	1.5		ns

Table 6-47. Switching Characteristics Over Recommended Operating Conditions for Programmable Synchronous Interface Cycles for EMIFA Module⁽¹⁾ (see Figure 6-24-Figure 6-26)

NO.	PARAMETER	720, 800, 900, 1100		UNIT
		MIN	MAX	
1	$t_d(EKOH-CEV)$ Delay time, AECLKOUT high to $\overline{ACE}x$ valid	1.3	4.9	ns
2	$t_d(EKOH-BEV)$ Delay time, AECLKOUT high to $\overline{ABE}x$ valid		4.9	ns
3	$t_d(EKOH-BEIV)$ Delay time, AECLKOUT high to $\overline{ABE}x$ invalid	1.3		ns
4	$t_d(EKOH-EAV)$ Delay time, AECLKOUT high to AEAx valid		4.9	ns
5	$t_d(EKOH-EAIV)$ Delay time, AECLKOUT high to AEAx invalid	1.3		ns
8	$t_d(EKOH-ADSV)$ Delay time, AECLKOUT high to $\overline{ASADS}/\overline{ASRE}$ valid	1.3	4.9	ns
9	$t_d(EKOH-OEV)$ Delay time, AECLKOUT high to $\overline{AAOE}/\overline{ASOE}$ valid	1.3	4.9	ns
10	$t_d(EKOH-EDV)$ Delay time, AECLKOUT high to AEDx valid		4.9	ns
11	$t_d(EKOH-EDIV)$ Delay time, AECLKOUT high to AEDx invalid	1.3		ns
12	$t_d(EKOH-WEV)$ Delay time, AECLKOUT high to $\overline{AAWE}/\overline{ASWE}$ valid	1.3	4.9	ns

(1) The following parameters are programmable via the EMIFA CE Configuration registers (CEnCFG):

- Read latency (R_LTNCY): 0-, 1-, 2-, or 3-cycle read latency
- Write latency (W_LTNCY): 0-, 1-, 2-, or 3-cycle write latency
- ACEx assertion length (CE_EXT): For standard SBSRAM or ZBT SRAM interface, $\overline{ACE}x$ goes inactive after the final command has been issued (CE_EXT = 0). For synchronous FIFO interface with glue, $\overline{ACE}x$ is active when $\overline{AAOE}/\overline{ASOE}$ is active (CE_EXT = 1).
- Function of ASADS/ASRE (R_ENABLE): For standard SBSRAM or ZBT SRAM interface, ASADS/ASRE has deselect cycles (R_ENABLE = 0). For FIFO interface, ASADS/ASRE has NO deselect cycles (R_ENABLE = 1).

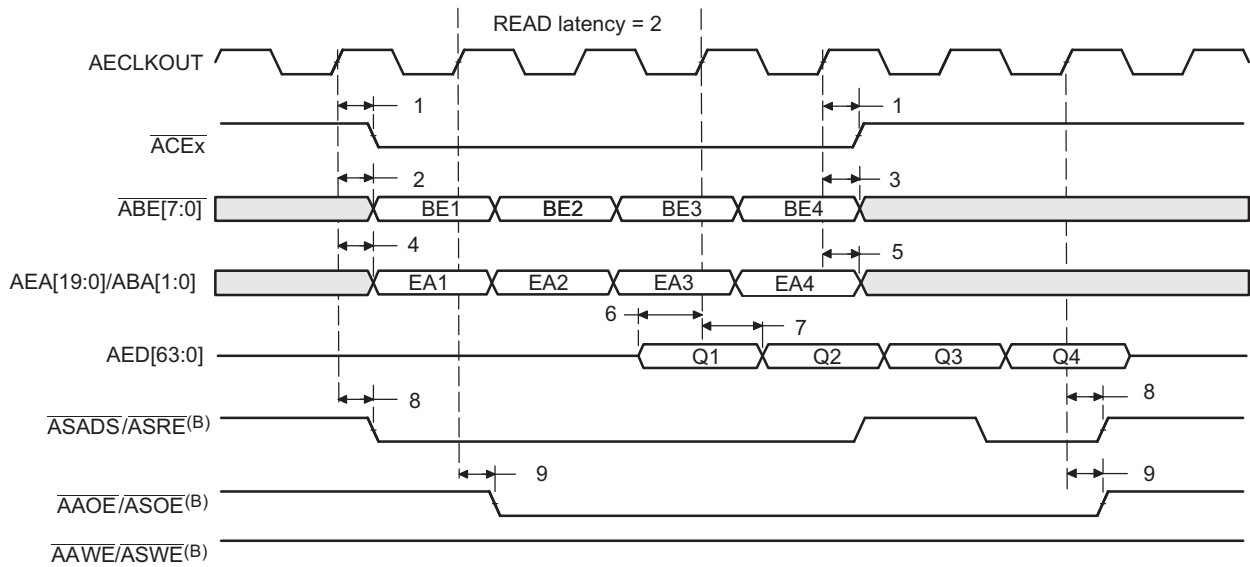

Figure 6-24. Programmable Synchronous Interface Read Timing for EMIFA (With Read Latency = 2)

NOTE

This information applies to [Figure 6-25](#) and [Figure 6-26](#).

The following parameters are programmable via the EMIF Chip Select n Configuration Register (CESECN):

- Read latency (R_LTNCY): 1-, 2-, or 3-cycle read latency
- Write latency (W_LTNCY): 0-, 1-, 2-, or 3-cycle write latency
- \overline{ACEx} assertion length (CE_EXT): For standard SBSRAM or ZBT SRAM interface, \overline{ACEx} goes inactive after the final command has been issued (CE_EXT = 0). For synchronous FIFO interface, \overline{ACEx} is active when $\overline{AAOE/ASOE}$ is active (CE_EXT = 1).
- Function of $\overline{ASADS/ASRE}$ (R_ENABLE): For standard SBSRAM or ZBT SRAM interface, $\overline{ASADS/ASRE}$ has deselect cycles (R_ENABLE = 0). For FIFO interface, $\overline{ASADS/ASRE}$ has NO deselect cycles (R_ENABLE = 1).

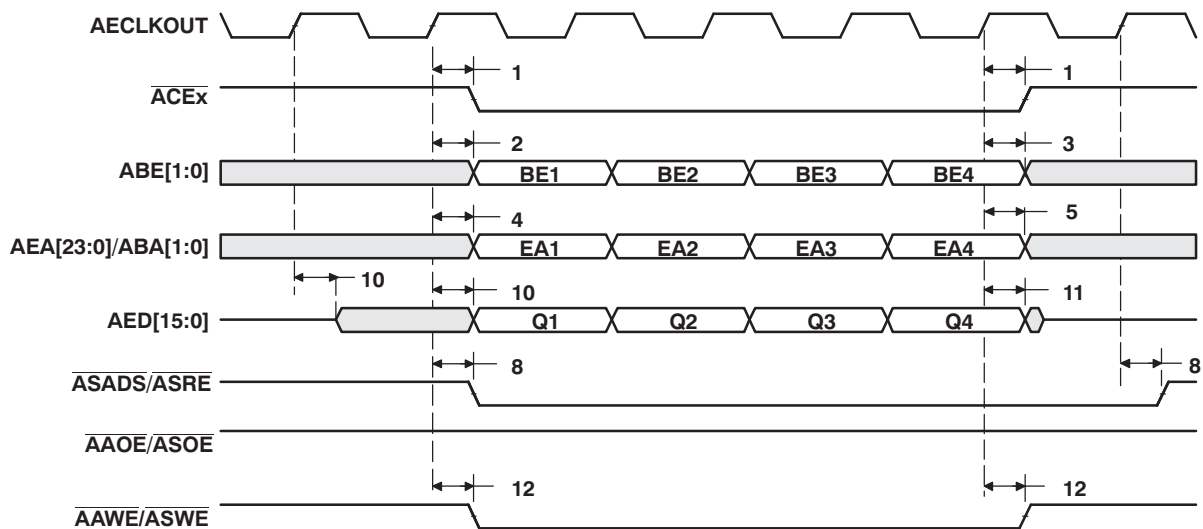

A. In this figure, W_LTNCY = 0, CE_EXT = 0, R_ENABLE = 0, and SSEL = 1.

Figure 6-25. Programmable Synchronous Interface Write Timing for EMIFA (With Write Latency = 0)

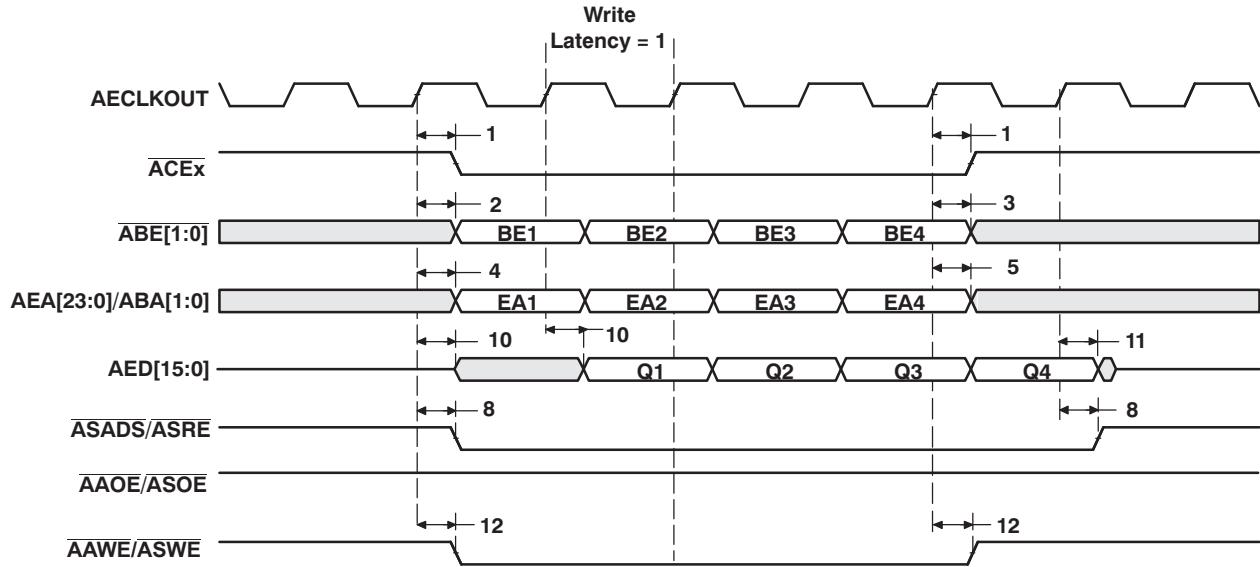

Figure 6-26. Programmable Synchronous Interface Write Timing for EMIFA (With Write Latency = 1)

6.11 Video Port

Each video port is capable of sending and receiving digital video data. The video ports are also capable of capturing/displaying RAW data. The video port peripherals follow video standards such as BT.656 and SMPTE296.

6.11.1 Video Port Device-Specific Information

The devices have five video port peripherals.

The video port peripheral can operate as a video capture port, video display port, or as a transport channel interface (TCI) capture port.

The port consists of two channels: A and B. A 5120-byte capture/display buffer is splittable between the two channels. The entire port (both channels) is always configured for either video capture or display only. Separate data pipelines control the parsing and formatting of video capture or display data for each of the BT.656, Y/C, raw video, and TCI modes.

For video capture operation, the video port may operate as two 8-bit channels of BT.656 or raw video capture; or as a single channel of 8-bit BT.656, 8-bit raw video, 8-bit Y/C video, 16-bit raw video, or 8-bit TCI.

For video display operation, the video port may operate as a single channel of 8-bit BT.656; or as a single channel of 8-bit BT.656, 8-bit raw video, 8-bit Y/C video, or 16-bit raw video. It may also operate in a two channel 8-bit raw mode in which the two channels are locked to the same timing. Channel B is not used during single channel operation.

For more detailed information on the video port peripherals, see the *TMS320DM647/DM648 Video Port User's Guide* (literature number [SPRUEM1](#)).

6.11.2 Video Port Peripheral Register Description(s)

Table 6-48. Video Port 0, 1, 2, 3, and 4 (VP0, VP1, VP2, VP3, and VP4) Control Registers

HEX ADDRESS RANGE					ACRONYM	DESCRIPTION
VP0	VP1	VP2	VP3	VP4		
0x02C0 0000	0x02C0 4000	0x02C0 8000	0x02C0 C000	0x02C1 0000	VPPID	Video Port Peripheral Identification Register
0x02C0 0004	0x02C0 4004	0x02C0 8004	0x02C0 C004	0x02C1 0004	PCR	Video Port Peripheral Control Register
0x02C0 0008	0x02C0 4008	0x02C0 8008	0x02C0 C008	0x02C1 0008	-	Reserved
0x02C0 000C	0x02C0 400C	0x02C0 800C	0x02C0 C00C	0x02C1 000C	-	Reserved
0x02C0 0020	0x02C0 4020	0x02C0 8020	0x02C0 C020	0x02C1 0020	PFUNC	Video Port Pin Function Register
0x02C0 0024	0x02C0 4024	0x02C0 8024	0x02C0 C024	0x02C1 0024	PDIR	Video Port Pin Direction Register
0x02C0 0028	0x02C0 4028	0x02C0 8028	0x02C0 C028	0x02C1 0028	PDIN	Video Port Pin Data Input Register
0x02C0 002C	0x02C0 402C	0x02C0 802C	0x02C0 C02C	0x02C1 002C	PDOUT	Video Port Pin Data Output Register
0x02C0 0030	0x02C0 4030	0x02C0 8030	0x02C0 C030	0x02C1 0030	PDSET	Video Port Pin Data Set Register
0x02C0 0034	0x02C0 4034	0x02C0 8034	0x02C0 C034	0x02C1 0034	PDCLR	Video Port Pin Data Clear Register
0x02C0 0038	0x02C0 4038	0x02C0 8038	0x02C0 C038	0x02C1 0038	PIEN	Video Port Pin Interrupt Enable Register
0x02C0 003C	0x02C0 403C	0x02C0 803C	0x02C0 C03C	0x02C1 003C	PIPOL	Video Port Pin Interrupt Polarity Register
0x02C0 0040	0x02C0 4040	0x02C0 8040	0x02C0 C040	0x02C1 0040	PISTAT	Video Port Pin Interrupt Status Register
0x02C0 0044	0x02C0 4044	0x02C0 8044	0x02C0 C044	0x02C1 0044	PICLR	Video Port Pin Interrupt Clear Register
0x02C0 00C0	0x02C0 40C0	0x02C0 80C0	0x02C0 C0C0	0x02C1 00C0	VPCTL	Video Port Control Register
0x02C0 00C4	0x02C0 40C4	0x02C0 80C4	0x02C0 C0C4	0x02C1 00C4	VPSTAT	Video Port Status Register
0x02C0 00C8	0x02C0 40C8	0x02C0 80C8	0x02C0 C0C8	0x02C1 00C8	VPIE	Video Port Interrupt Enable Register
0x02C0 00CC	0x02C0 40CC	0x02C0 80CC	0x02C0 C0CC	0x02C1 00CC	VPISTAT	Video Port interrupt Status Register
0x02C0 0100	0x02C0 4100	0x02C0 8100	0x02C0 C100	0x02C1 0100	VCASTAT	Video Capture Channel A Status Register
0x02C0 0104	0x02C0 4104	0x02C0 8104	0x02C0 C104	0x02C1 0104	VCACTL	Video Capture Channel A Control Register

Table 6-48. Video Port 0, 1, 2, 3, and 4 (VP0, VP1, VP2, VP3, and VP4) Control Registers (continued)

HEX ADDRESS RANGE					ACRONYM	DESCRIPTION
VP0	VP1	VP2	VP3	VP4		
0x02C0 0108	0x02C0 4108	0x02C0 8108	0x02C0 C108	0x02C1 0108	VCASTR1	Video Capture Channel A Field 1 Start Register
0x02C0 010C	0x02C0 410C	0x02C0 810C	0x02C0 C10C	0x02C1 010C	VCASTOP1	Video Capture Channel A Field 1 Stop Register
0x02C0 0110	0x02C0 4110	0x02C0 8110	0x02C0 C110	0x02C1 0110	VCASTR2	Video Capture Channel A Field 2 Start Register
0x02C0 0114	0x02C0 4114	0x02C0 8114	0x02C0 C114	0x02C1 0114	VCASTOP2	Video Capture Channel A Field 2 Stop Register
0x02C0 0118	0x02C0 4118	0x02C0 8118	0x02C0 C118	0x02C1 0118	VCAVINT	Video Capture Channel A Vertical Interrupt Register
0x02C0 011C	0x02C0 411C	0x02C0 811C	0x02C0 C11C	0x02C1 011C	VCATHRLD	Video Capture Channel A Threshold Register
0x02C0 0120	0x02C0 4120	0x02C0 8120	0x02C0 C120	0x02C1 0120	VCAEVTCT	Video Capture Channel A Event Count Register
0x02C0 0140	0x02C0 4140	0x02C0 8140	0x02C0 C140	0x02C1 0140	VCBSTAT	Video Capture Channel B Status Register
0x02C0 0144	0x02C0 4144	0x02C0 8144	0x02C0 C144	0x02C1 0144	VCBCTL	Video Capture Channel B Control Register
0x02C0 0148	0x02C0 4148	0x02C0 8148	0x02C0 C148	0x02C1 0148	VCBSTR1	Video Capture Channel B Field 1 Start Register
0x02C0 014C	0x02C0 414C	0x02C0 814C	0x02C0 C14C	0x02C1 014C	VCBSTOP1	Video Capture Channel B Field 1 Stop Register
0x02C0 0150	0x02C0 4150	0x02C0 8150	0x02C0 C150	0x02C1 0150	VCBSTR2	Video Capture Channel B Field 2 Start Register
0x02C0 0154	0x02C0 4154	0x02C0 8154	0x02C0 C154	0x02C1 0154	VCBSTOP2	Video Capture Channel B Field 2 Stop Register
0x02C0 0158	0x02C0 4158	0x02C0 8158	0x02C0 C158	0x02C1 0158	VCBVINT	Video Capture Channel B Vertical Interrupt Register
0x02C0 015C	0x02C0 415C	0x02C0 815C	0x02C0 C15C	0x02C1 015C	VCBTHRLD	Video Capture Channel B Threshold Register
0x02C0 0160	0x02C0 4160	0x02C0 8160	0x02C0 C160	0x02C1 0160	VCBEVTCT	Video Capture Channel B Event Count Register
0x02C0 0180	0x02C0 4180	0x02C0 8180	0x02C0 C180	0x02C1 0180	TCICLTL	TCI Capture Control Register
0x02C0 0184	0x02C0 4184	0x02C0 8184	0x02C0 C184	0x02C1 0184	TCICLKINITL	TCI Clock Initialization LSB Register
0x02C0 0188	0x02C0 4188	0x02C0 8188	0x02C0 C188	0x02C1 0188	TCICLKINITM	TCI Clock Initialization MSB Register
0x02C0 018C	0x02C0 418C	0x02C0 818C	0x02C0 C18C	0x02C1 018C	TCISTCLKL	TCI System Time Clock LSB Register
0x02C0 0190	0x02C0 4190	0x02C0 8190	0x02C0 C190	0x02C1 0190	TCISTCLKM	TCI System Time Clock MSB Register
0x02C0 0194	0x02C0 4194	0x02C0 8194	0x02C0 C194	0x02C1 0194	TCISTCMPL	TCI System Time Clock Compare LSB Register
0x02C0 0198	0x02C0 4198	0x02C0 8198	0x02C0 C198	0x02C1 0198	TCISTCMPM	TCI System Time Clock Compare MSB Register
0x02C0 019C	0x02C0 419C	0x02C0 819C	0x02C0 C19C	0x02C1 019C	TCISTMSKL	TCI System Time Clock Compare Mask LSB Register
0x02C0 01A0	0x02C0 41A0	0x02C0 81A0	0x02C0 C1A0	0x02C1 01A0	TCISTMSKM	TCI System Time Clock Compare Mask MSB Register
0x02C0 01A4	0x02C0 41A4	0x02C0 81A4	0x02C0 C1A4	0x02C1 01A4	TCITICKS	TCI System Time Clock Ticks Interrupt Register
0x02C0 0200	0x02C0 4200	0x02C0 8200	0x02C0 C200	0x02C1 0200	VDSTAT	Video Display Status Register
0x02C0 0204	0x02C0 4204	0x02C0 8204	0x02C0 C204	0x02C1 0204	VDCTL	Video Display Control Register
0x02C0 0208	0x02C0 4208	0x02C0 8208	0x02C0 C208	0x02C1 0208	VDFRMSZ	Video Display Frame Size Register
0x02C0 020C	0x02C0 420C	0x02C0 820C	0x02C0 C20C	0x02C1 020C	VDHBLNK	Video Display Horizontal Blanking Register
0x02C0 0210	0x02C0 4210	0x02C0 8210	0x02C0 C210	0x02C1 0210	VDVBLKS1	Video Display Field 1 Vertical Blanking Start Register
0x02C0 0214	0x02C0 4214	0x02C0 8214	0x02C0 C214	0x02C1 0214	VDVBLKE1	Video Display Field 1 Vertical Blanking End Register
0x02C0 0218	0x02C0 4218	0x02C0 8218	0x02C0 C218	0x02C1 0218	VDVBLKS2	Video Display Field 2 Vertical Blanking Start Register
0x02C0 021C	0x02C0 421C	0x02C0 821C	0x02C0 C21C	0x02C1 021C	VDVBLKE2	Video Display Field 2 Vertical Blanking End Register

Table 6-48. Video Port 0, 1, 2, 3, and 4 (VP0, VP1, VP2, VP3, and VP4) Control Registers (continued)

HEX ADDRESS RANGE					ACRONYM	DESCRIPTION
VP0	VP1	VP2	VP3	VP4		
0x02C0 0220	0x02C0 4220	0x02C0 8220	0x02C0 C220	0x02C1 0220	VDIMGOFF1	Video Display Field 1 Image Offset Register
0x02C0 0224	0x02C0 4224	0x02C0 8224	0x02C0 C224	0x02C1 0224	VDIMGSZ1	Video Display Field 1 Image Size Register
0x02C0 0228	0x02C0 4228	0x02C0 8228	0x02C0 C228	0x02C1 0228	VDIMGOFF2	Video Display Field 2 Image Offset Register
0x02C0 022C	0x02C0 422C	0x02C0 822C	0x02C0 C22C	0x02C1 022C	VDIMGSZ2	Video Display Field 2 Image Size Register
0x02C0 0230	0x02C0 4230	0x02C0 8230	0x02C0 C230	0x02C1 0230	VDFLDT1	Video Display Field 1 Timing Register
0x02C0 0234	0x02C0 4234	0x02C0 8234	0x02C0 C234	0x02C1 0234	VDFLDT2	Video Display Field 2 Timing Register
0x02C0 0238	0x02C0 4238	0x02C0 8238	0x02C0 C238	0x02C1 0238	VDTHRLD	Video Display Threshold Register
0x02C0 023C	0x02C0 423C	0x02C0 823C	0x02C0 C23C	0x02C1 023C	VDHSYNC	Video Display Horizontal Synchronization Register
0x02C0 0240	0x02C0 4240	0x02C0 8240	0x02C0 C240	0x02C1 0240	VDVSYNS1	Video Display Field 1 Vertical Synchronization Start Register
0x02C0 0244	0x02C0 4244	0x02C0 8244	0x02C0 C244	0x02C1 0244	VDVSYNE1	Video Display Field 1 Vertical Synchronization End Register
0x02C0 0248	0x02C0 4248	0x02C0 8248	0x02C0 C248	0x02C1 0248	VDVSYNS2	Video Display Field 2 Vertical Synchronization Start Register
0x02C0 024C	0x02C0 424C	0x02C0 824C	0x02C0 C24C	0x02C1 024C	VDVSYNE2	Video Display Field 2 Vertical Synchronization End Register
0x02C0 0250	0x02C0 4250	0x02C0 8250	0x02C0 C250	0x02C1 0250	VDRELOAD	Video Display Counter Reload Register
0x02C0 0254	0x02C0 4254	0x02C0 8254	0x02C0 C254	0x02C1 0254	VDDISPEVT	Video Display Event Register
0x02C0 0258	0x02C0 4258	0x02C0 8258	0x02C0 C258	0x02C1 0258	VDCLIP	Video Display Clipping Register
0x02C0 025C	0x02C0 425C	0x02C0 825C	0x02C0 C25C	0x02C1 025C	VDDEFVAL	Video Display Default Display Value Register
0x02C0 0260	0x02C0 4260	0x02C0 8260	0x02C0 C260	0x02C1 0260	VDVINT	Video Display Vertical Interrupt Register
0x02C0 0264	0x02C0 4264	0x02C0 8264	0x02C0 C264	0x02C1 0264	VDFBIT	Video Display Field Bit Register
0x02C0 0268	0x02C0 4268	0x02C0 8268	0x02C0 C268	0x02C1 0268	VDVBIT1	Video Display Field 1 Vertical Blanking Bit Register
0x02C0 026C	0x02C0 426C	0x02C0 826C	0x02C0 C26C	0x02C1 026C	VDVBIT2	Video Display Field 2 Vertical Blanking Bit Register
0x5000 0000	0x5400 0000	0x5800 0000	0x6000 0000	0x6400 0000	YSRCA	Y FIFO Source Register A
0x5000 0020	0x5400 0020	0x5800 0020	0x6000 0020	0x6400 0020	CBSRCA	CB FIFO Source Register A
0x5000 0040	0x5400 0040	0x5800 0040	0x6000 0040	0x6400 0040	CRSRCA	CR FIFO Source Register A
0x5000 0080	0x5400 0080	0x5800 0080	0x6000 0080	0x6400 0080	YDSTA	Y FIFO Destination Register A
0x5000 00A0	0x5400 00A0	0x5800 00A0	0x6000 00A0	0x6400 00A0	CBDST	CB FIFO Destination Register
0x5000 00C0	0x5400 00C0	0x5800 00C0	0x6000 00C0	0x6400 00C0	CRDST	CR FIFO Destination Register
0x5200 0000	0x5600 0000	0x5A00 0000	0x6200 0000	0x6600 0000	YSRCB	Y FIFO Source Register B
0x5200 0020	0x5600 0020	0x5A00 0020	0x6200 0020	0x6600 0020	CBSRCB	CB FIFO Source Register B
0x5200 0040	0x5600 0040	0x5A00 0040	0x6200 0040	0x6600 0040	CRSRCB	CR FIFO Source Register B
0x5200 0080	0x5600 0080	0x5A00 0080	0x6200 0080	0x6600 0080	YDSTB	Y FIFO Destination Register B

6.11.3 Video Port (VP0, VP1, VP2, VP3, VP4) Electrical Data/Timing

6.11.3.1 VCLKIN Timing (Video Capture Mode)

Table 6-49. Timing Requirements for Video Capture Mode for VPxCLKINx⁽¹⁾
(see Figure 6-27)

NO.			-720 -800 -900 -1100		UNIT
			MIN	MAX	
1	$t_{c(VKI)}$	Cycle time, VPxCLKINx	9.259		ns
2	$t_{w(VKIH)}$	Pulse duration, VPxCLKINx high	4.2		ns
3	$t_{w(VKIL)}$	Pulse duration, VPxCLKINx low	4.2		ns
4	$t_{t(VKI)}$	Transition time, VPxCLKINx		3	ns

(1) The reference points for the rise and fall transitions are measured at V_{IL} MAX and V_{IH} MIN.

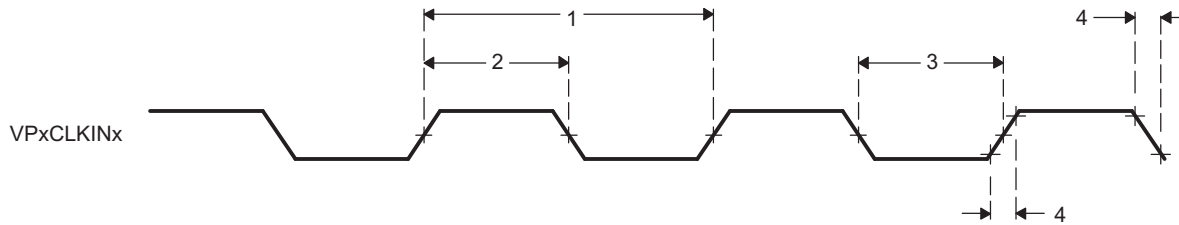

Figure 6-27. Video Port Capture VPxCLKINx Timing

6.11.3.2 Video Data and Control Timing (Video Capture Mode)

Table 6-50. Timing Requirements in Video Capture Mode for Video Data and Control Inputs
(see Figure 6-28)

NO.			-720 -800 -900 -1100		UNIT
			MIN	MAX	
1	$t_{su}(VDATV-VKIH)$	Setup time, VPxDx valid before VPxCLKINx high	2.4		ns
2	$t_h(VDATV-VKIH)$	Hold time, VPxDx valid after VPxCLKINx high	0.5		ns
3	$t_{su}(VCTLV-VKIH)$	Setup time, VPxCTLx valid before VPxCLKINx high	2.4		ns
4	$t_h(VCTLV-VKIH)$	Hold time, VPxCTLx valid after VPxCLKINx high	0.5		ns

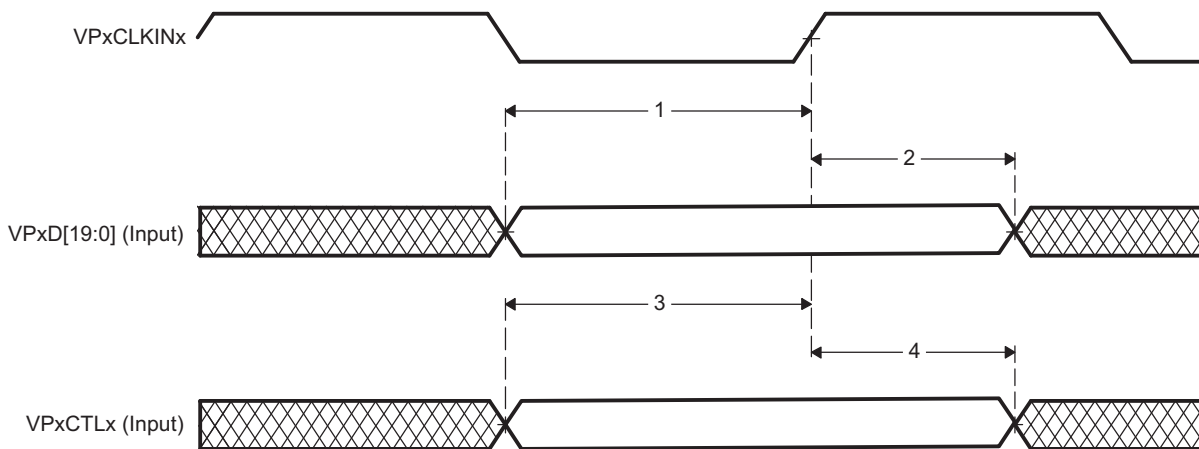

Figure 6-28. Video Port Capture Data and Control Input Timing

6.11.3.3 VCLKIN Timing (Video Display Mode)

Table 6-51. Timing Requirements for Video Display Mode for VPxCLKINx⁽¹⁾ (see Figure 6-29)

NO.			-720 -800 -900 -1100		UNIT
			MIN	MAX	
1	$t_{c(VKI)}$	Cycle time, VPxCLKINx	9		ns
2	$t_{w(VKIH)}$	Pulse duration, VPxCLKINx high	4.1		ns
3	$t_{w(VKIL)}$	Pulse duration, VPxCLKINx low	4.1		ns
4	$t_{t(VKI)}$	Transition time, VPxCLKINx	3		ns

(1) The reference points for the rise and fall transitions are measured at V_{IL} MAX and V_{IH} MIN.

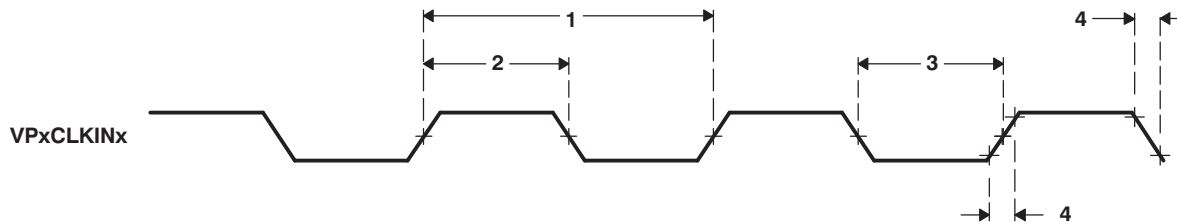

Figure 6-29. Video Port Display VPxCLKINx Timing

6.11.3.4 Video Control Input/Output and Video Display Data Output Timing With Respect to VPxCLKINx and VPxCLKOUTx (Video Display Mode)

Table 6-52. Timing Requirements in Video Display Mode for Video Control Input Shown With Respect to VPxCLKINx and VPxCLKOUTx (see Figure 6-30)

NO.			-720 -800 -900 -1100		UNIT
			MIN	MAX	
13	$t_{su(VCTLV-VKIH)}$	Setup time, VPxCTLx valid before VPxCLKINx high	2.4		ns
14	$t_h(VCTLV-VKIH)$	Hold time, VPxCTLx valid after VPxCLKINx high	0.5		ns
15	$t_{su(VCTLV-VKOH)}$	Setup time, VPxCTLx valid before VPxCLKOUTx high ⁽¹⁾	7.4		ns
16	$t_h(VCTLV-VKOH)$	Hold time, VPxCTLx valid after VPxCLKOUTx high ⁽¹⁾	-0.9		ns

(1) Assuming non-inverted VPxCLKOUTx signal.

Table 6-53. Switching Characteristics Over Recommended Operating Conditions in Video Display Mode for Video Data and Control Output Shown With Respect to VPxCLKINx and VPxCLKOUTx^{(1) (2)}
(see Figure 6-30)

NO.	PARAMETER	-720 -800 -900 -1100		UNIT
		MIN	MAX	
1	$t_{c(VKO)}$ Cycle time, VPxCLKOUTx	V - 0.7	V + 0.7	ns
2	$t_{w(VKOH)}$ Pulse duration, VPxCLKOUTx high	VH - 0.7	VH + 0.7	ns
3	$t_{w(VKOL)}$ Pulse duration, VPxCLKOUTx low	VL - 0.7	VL + 0.7	ns
4	$t_t(VKO)$ Transition time, VPxCLKOUTx		1.8	ns
5	$t_{d(VKIH-VKOH)}$ Delay time, VPxCLKINx high to VPxCLKOUTx high ⁽³⁾		5	ns
6	$t_{d(VKIL-VKOL)}$ Delay time, VPxCLKINx low to VPxCLKOUTx low ⁽³⁾		5	ns
7	$t_{d(VKIH-VKOL)}$ Delay time, VPxCLKINx high to VPxCLKOUTx low		5	ns
8	$t_{d(VKIL-VKOH)}$ Delay time, VPxCLKINx low to VPxCLKOUTx high		5	ns
9	$t_{d(VKIH-VPOUTV)}$ Delay time, VPxCLKINx high to VPxOUT valid ⁽⁴⁾		7	ns
10	$t_{d(VKIH-VPOUTIV)}$ Delay time, VPxCLKINx high to VPxOUT invalid ⁽⁴⁾	1.7		ns
11	$t_{d(VKOH-VPOUTV)}$ Delay time, VPxCLKOUTx high to VPxOUT valid ^{(1) (4)}		4.7	ns
12	$t_{d(VKOH-VPOUTIV)}$ Delay time, VPxCLKOUTx high to VPxOUT invalid ^{(1) (4)}	0.7		ns

- (1) V = the video input clock (VPxCLKINx) period in ns.
- (2) VH is the high period of V (video input clock period) in ns and VL is the low period of V (video input clock period) in ns.
- (3) Assuming non-inverted VPxCLKOUTx signal.
- (4) VPxOUT consists of VPxCTLx and VPxD[19:0]

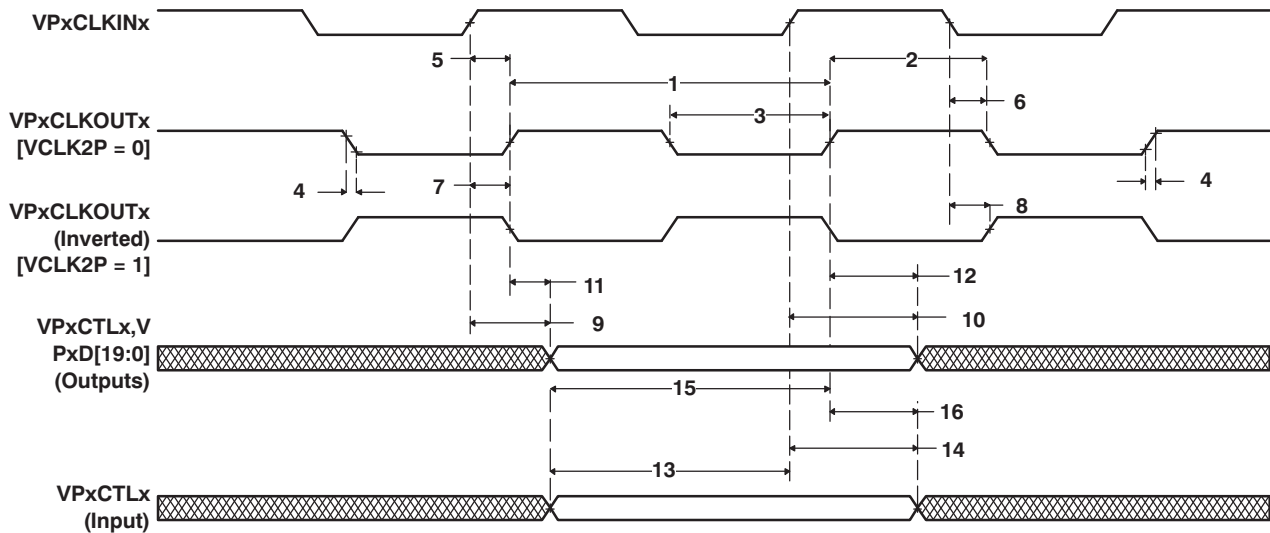

Figure 6-30. Video Port Display Data Output Timing and Control Input/Output Timing With Respect to VPxCLKINx and VPxCLKOUTx

6.11.3.5 Video Dual-Display Sync Mode Timing (With Respect to VPxCLKINx)

Table 6-54. Timing Requirements for Dual-Display Sync Mode for VPxCLKINx (see Figure 6-31)

NO.		-720 Placement="line"/>-800 Placement="line"/>-900 -1100		UNIT
		MIN	MAX	
1	$t_{skr(VKI)}$ Skew rate, VPxCLKINx before VPyCLKINy		± 500	ps

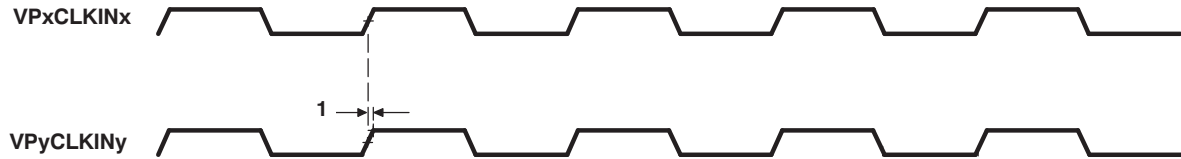

Figure 6-31. Video Port Dual-Display Sync Timing

6.12 VCXO Interpolated Control (VIC)

The VIC can be used in conjunction with the video ports (VPs) to maintain synchronization of a video stream. The VIC can also be used to control a VCXO to adjust the pixel clock rate to a video port.

6.12.1 VIC Device-Specific Information

The VCXO interpolated control (VIC) port provides digital-to-analog conversation with resolution from 9-bits to up to 16-bits. The output of the VIC is a single bit interpolated D/A output (VDAC pin).

Typical D/A converters provide a discrete output level for every value of the digital word that is being converted. This is a problem for digital words that are long. This is avoided in a Sigma Delta type D/A converter by choosing a few widely spaced output levels and interpolating values between them. The interpolating mechanism causes the output to oscillate rapidly between the levels in such a manner that the average output represents the value of input code.

In the VIC, two output levels are chosen (0 and 1), and Sigma Delta interpolation scheme is implemented to interpolate between these levels with a rapidly changing signal. The frequency of interpolation is dependent on the resolution needed.

When the video port is used in transport channel interface (TCI) mode, the VIC port is used to control the system clock, VCXO, for MPEG transport stream.

The VIC supports the following features:

- Single interpolation for D/A conversion
- Programmable precision from 9-to-16 bits
- Interface for register accesses

For more detailed information on the VCXO interpolated control (VIC) peripheral, see the *TMS320DM647/DM648 Video Port User's Guide* (literature number [SPRUJEM1](#)).

6.12.2 VIC Peripheral Register Description(s)

Table 6-55. VCXO Interpolated Control (VIC) Port Registers

HEX ADDRESS RANGE	ACRONYM	REGISTER NAME
0x0204 7400	VICCTL	VIC control register
0x0204 7404	VICIN	VIC input register
0x0204 7408	VPDIV	VIC clock divider register
0x0204 740C - 0x0204 77FF	-	Reserved

6.12.3 VIC Electrical Data/Timing

6.12.3.1 STCLK Timing

Table 6-56. Timing Requirements for STCLK⁽¹⁾ (see Figure 6-32)

NO.			-720 -800 -900 -1100		UNIT
			MIN	MAX	
1	$t_c(\text{STCLK})$	Cycle time, STCLK	33.3		ns
2	$t_w(\text{STCLKH})$	Pulse duration, STCLK high	16		ns
3	$t_w(\text{STCLKL})$	Pulse duration, STCLK low	16		ns
4	$t_t(\text{STCLK})$	Transition time, STCLK	3		ns

(1) The reference points for the rise and fall transitions are measured at V_{IL} MAX and V_{IH} MIN.

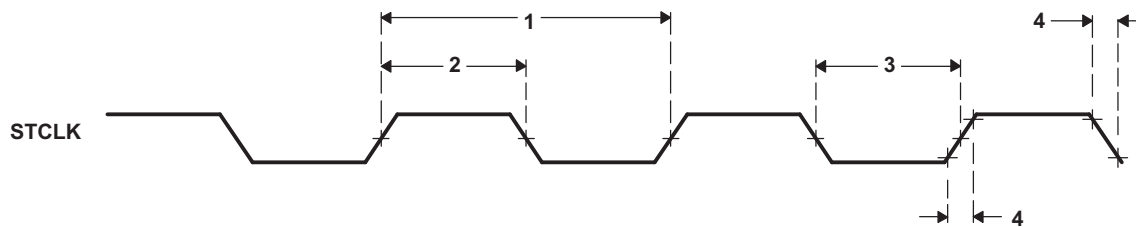

Figure 6-32. STCLK Timing

6.13 Universal Asynchronous Receiver/Transmitter (UART)

The device has a UART peripheral. The UART has the following features:

- 16-byte storage space for both the transmitter and receiver FIFOs
- 1, 4, 8, or 14 byte selectable receiver FIFO trigger level for autoflow control and DMA
- DMA signaling capability for both received and transmitted data
- Programmable auto-rts and auto-cts for autoflow control
- Frequency pre-scale values from 1 to 65, 535 to generate appropriate baud rates
- Prioritized interrupts
- Programmable serial data formats
 - 5, 6, 7, or 8-bit characters
 - Even, odd, or no parity bit generation and detection
 - 1, 1.5, or 2 stop bit generation
- False start bit detection
- Line break generation and detection
- Internal diagnostic capabilities
 - Loopback controls for communications link fault isolation
 - Break, parity, overrun, and framing error simulation
- Modem control functions (CTS, RTS).

The UART registers are listed in [Table 6-57](#) .

6.13.1 UART Peripheral Register Description(s)

Table 6-57. UART Register Descriptions

HEX ADDRESS RANGE	ACRONYM	REGISTER NAME
0x0204 7000	RBR	UART Receiver Buffer Register (Read Only)
0x0204 7000	THR	UART Transmitter Holding Register (Write Only)
0x0204 7004	IER	UART Interrupt Enable Register
0x0204 7008	IIR	UART Interrupt Identification Register (Read Only)
0x0204 7008	FCR	UART FIFO Control Register (Write Only)
0x0204 700C	LCR	UART Line Control Register
0x0204 7010	MCR	UART Modem Control Register
0x0204 7014	LSR	UART Line Status Register
0x0204 7018	-	Reserved
0x0204 701C	-	Reserved
0x0204 7020	DLL	UART Divisor Latch (LSB)
0x0204 7024	DLH	UART Divisor Latch (MSB)
0x0204 7028	PID	Peripheral Identification Register
0x0204 702C		Reserved
0x0204 7030	PWREMU_MGMT	UART Power and Emulation Management Register
0x0204 7034	MDR	Mode Definition Register
0x0204 7038 - 0x0204 73FF	-	Reserved

6.13.2 UART Electrical Data/Timing

Table 6-58. Timing Requirements for UARTx Receive⁽¹⁾ (see Figure 6-33)

NO.			720, 800, 900, 1100		UNIT
			MIN	MAX	
4	$t_{w(URXDB)}$	Pulse duration, receive data bit (RXDn) [15/30/100 pF]	0.96U	1.05U	ns
5	$t_{w(URXSB)}$	Pulse duration, receive start bit [15/30/100 pF]	0.96U	1.05U	ns

(1) U = UART baud time = 1/programmed baud rate.

Table 6-59. Switching Characteristics Over Recommended Operating Conditions for UARTx Transmit⁽¹⁾ (see Figure 6-33)

NO.	PARAMETER	720, 800, 900, 1100		UNIT
		MIN	MAX	
1	$f_{(baud)}$	Maximum programmable baud rate		5
2	$t_{w(UTXDB)}$	U - 2	U + 2	ns
3	$t_{w(UTXSB)}$	U - 2	U + 2	ns

(1) U = UART baud time = 1/programmed baud rate.

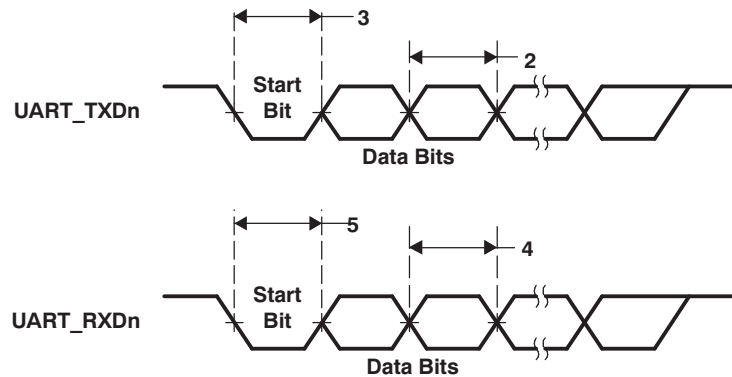

Figure 6-33. UART Transmit/Receive Timing

6.14 Serial Peripheral Interface Port (SPI)

6.14.1 SPI Device-Specific Information

Figure 6-34 is a block diagram of the SPI module, which is a simple shift register and buffer plus control logic. Data is written to the shift register before transmission occurs and is read from the buffer at the end of transmission. The SPI can operate only as a master, in which case, it initiates a transfer and drives the SPICLK pin. Four clock phase and polarity options are supported as well as many data formatting options.

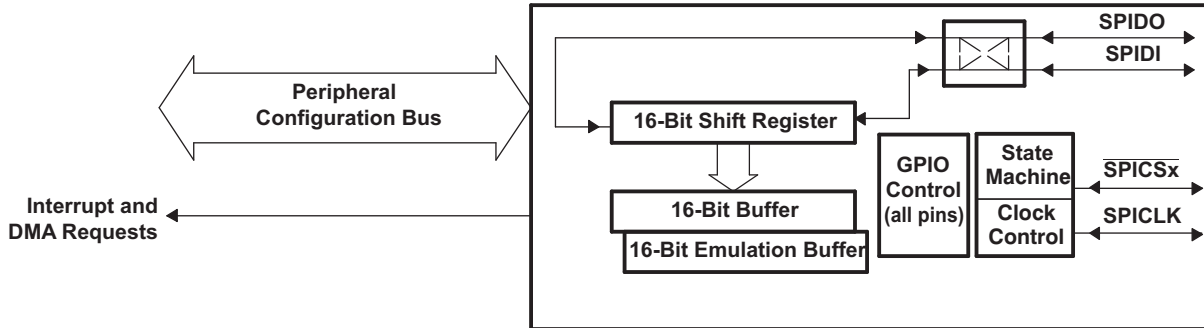

Figure 6-34. Block Diagram of SPI Module

The SPI supports 3- and 4-pin operation with three basic pins (SPICLK, SPIDO, and SPIDI) and two optional pins ($\overline{\text{SPICSn}}$).

The optional $\overline{\text{SPICSn}}$ (Slave Chip Select) pin is most useful to enable in master mode when there are more than one slave devices on the same SPI port. The device only shifts data and drives the SPIDI pin when $\overline{\text{SPICSn}}$ is held low.

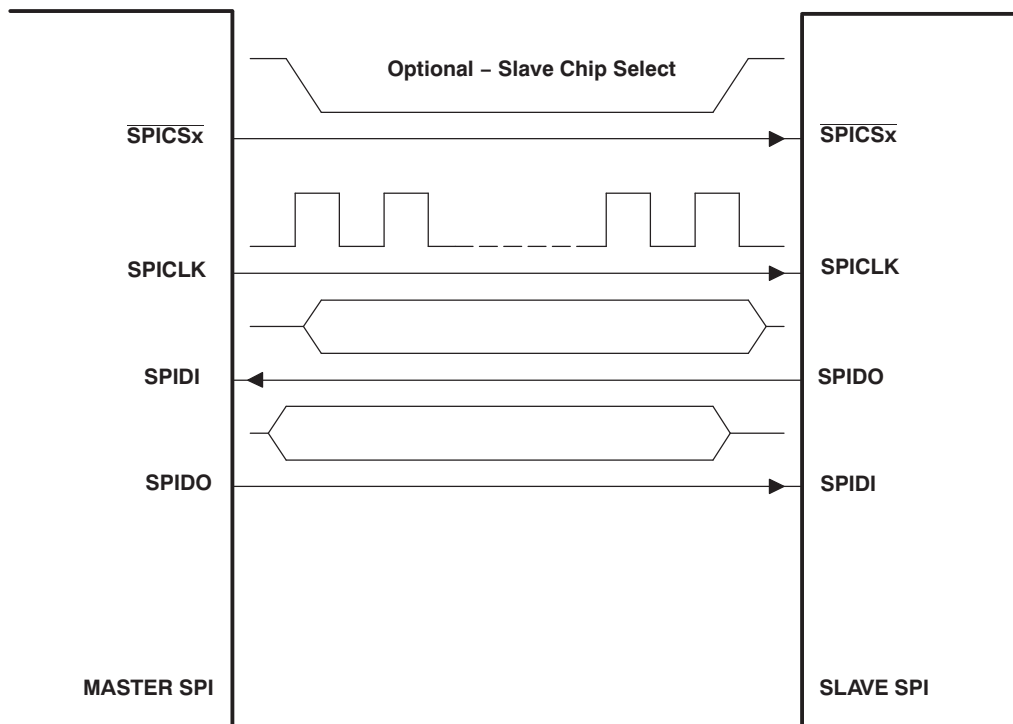

Figure 6-35. Illustration of SPI Master-to-SPI Slave Connection

6.14.2 SPI Peripheral Register Descriptions

Table 6-60 is a list of the SPI registers.

Table 6-60. SPI Configuration Registers

SPI0 BYTE ADDRESS	REGISTER NAME	DESCRIPTION
0x0204 7800	SPIGCR0	Global Control Register 0
0x0204 7804	SPIGCR1	Global Control Register 1
0x0204 7808	SPIINT0	Interrupt Register
0x0204 780C	SPIVLV	Interrupt Level Register
0x0204 7810	SPIFLG	Flag Register
0x0204 7814	SPIPC0	Pin Control Register 0 (Pin Function)
0x0204 7818	SPIPC1	Pin Control Register 1 (Pin Direction)
0x0204 781C	SPIPC2	Pin Control Register 2 (Pin Data In)
0x0204 783C	SPIDAT1	Shift Register 1 (with format select)
0x0204 7840	SPIBUF	Buffer Register
0x0204 7844	SPIEMU	Emulation Register
0x0204 7848	SPIDELAY	Delay Register
0x0204 784C	SPIDEF	Default Chip Select Register
0x0204 7850	SPIFMT0	Format Register 0
0x0204 7854	SPIFMT1	Format Register 1
0x0204 7858	SPIFMT2	Format Register 2
0x0204 785C	SPIFMT3	Format Register 3
0x0204 7860	TGINTVECT0	Interrupt Vector for SPI INT0
0x0204 7864	TGINTVECT1	Interrupt Vector for SPI INT1

6.14.3 SPI Electrical Data/Timing

6.14.3.1 Serial Peripheral Interface (SPI) Timing

Table 6-61 assumes testing over recommended operating conditions (see Figure 6-36).

Table 6-61. General Timing Requirements for SPIx Master Modes⁽¹⁾

NO.			MIN	MAX	UNIT
1	$t_{c(SPC)M}$	Cycle Time, SPICLK, All Master Modes	greater of 8P or 100 ns	256P	ns
2	$t_{w(SPCH)M}$	Pulse Width High, SPICLK, All Master Modes	greater of 4P or 45 ns		ns
3	$t_{w(SPCL)M}$	Pulse Width Low, SPICLK, All Master Modes	greater of 4P or 45 ns		ns
4	$t_{d(SIMO_SPC)M}$	Delay, initial data bit valid on SPIDO to initial edge on SPICLK ⁽²⁾	Polarity = 0, Phase = 0, to SPICLK rising	4P	ns
			Polarity = 0, Phase = 1, to SPICLK rising	$0.5t_{c(SPC)M} + 4P$	
			Polarity = 1, Phase = 0, to SPICLK falling	4P	
			Polarity = 1, Phase = 1, to SPICLK falling	$0.5t_{c(SPC)M} + 4P$	
5	$t_{d(SPC_SIMO)M}$	Delay, subsequent bits valid on SPIDO after transmit edge of SPICLK	Polarity = 0, Phase = 0, from SPICLK rising	15	ns
			Polarity = 0, Phase = 1, from SPICLK falling	15	
			Polarity = 1, Phase = 0, from SPICLK falling	15	
			Polarity = 1, Phase = 1, from SPICLK rising	15	
6	$t_{oh(SPC_SIMO)M}$	Output hold time, SPIDO valid after receive edge of SPICLK, except for final bit ⁽³⁾	Polarity = 0, Phase = 0, from SPICLK falling	$0.5t_{c(SPC)M} - 10$	ns
			Polarity = 0, Phase = 1, from SPICLK rising	$0.5t_{c(SPC)M} - 10$	
			Polarity = 1, Phase = 0, from SPICLK rising	$0.5t_{c(SPC)M} - 10$	
			Polarity = 1, Phase = 1, from SPICLK falling	$0.5t_{c(SPC)M} - 10$	
7	$t_{su(SOML_SPC)M}$	Input Setup Time, SPIDI valid before receive edge of SPICLK	Polarity = 0, Phase = 0, to SPICLK falling	$0.5P + 15$	ns
			Polarity = 0, Phase = 1, to SPICLK rising	$0.5P + 15$	
			Polarity = 1, Phase = 0, to SPICLK rising	$0.5P + 15$	
			Polarity = 1, Phase = 1, to SPICLK falling	$0.5P + 15$	
8	$t_{ih(SPC_SOMI)M}$	Input Hold Time, SPIDI valid after receive edge of SPICLK	Polarity = 0, Phase = 0, from SPICLK falling	$0.5P + 5$	ns
			Polarity = 0, Phase = 1, from SPICLK rising	$0.5P + 5$	
			Polarity = 1, Phase = 0, from SPICLK rising	$0.5P + 5$	
			Polarity = 1, Phase = 1, from SPICLK falling	$0.5P + 5$	

(1) P = SYSCLK3 period

(2) First bit may be MSB or LSB depending upon SPI configuration. MO(0) refers to first bit and MO(n) refers to last bit output on SPIDO. MI(0) refers to the first bit input and MI(n) refers to the last bit input on SPIDI.

(3) The final data bit will be held on the SPIDO pin until the SPIDAT1 register is written with new data.

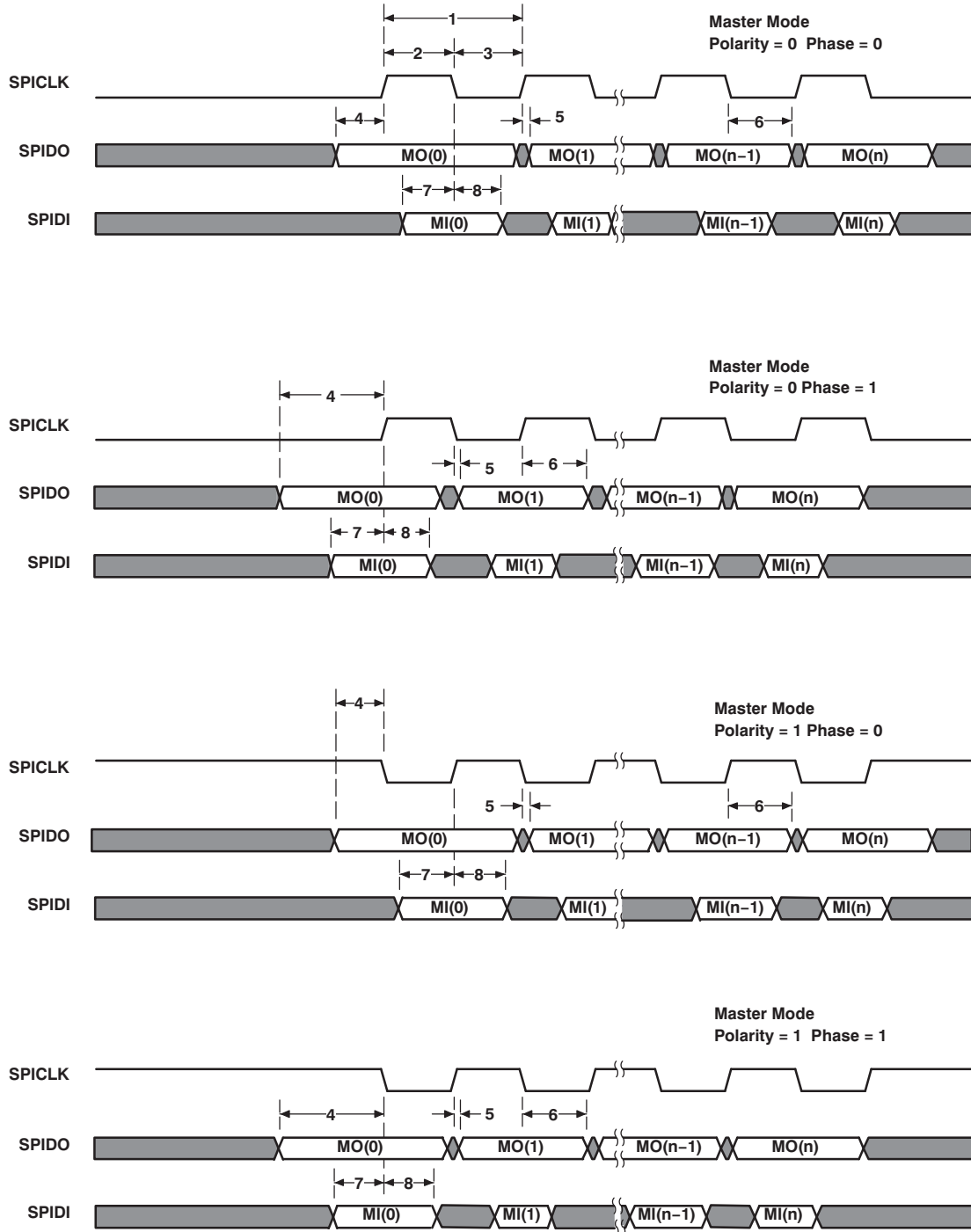

Figure 6-36. SPI Timings—Master Mode

6.15 Inter-Integrated Circuit (I2C)

The inter-integrated circuit (I2C) module provides an interface between the DM647/DM648 device and other devices compliant with Philips Semiconductors Inter-IC bus (I2C-bus™) specification version 2.1. External components attached to this 2-wire serial bus can transmit/receive up to 8-bit data to/from the DSP through the I2C module. The I2C port *does not* support CBUS-compatible devices.

The I2C port supports:

- Compatible with Philips I2C Specification Revision 2.1 (January 2000)
- Fast Mode up to 400 Kbps (no fail-safe I/O buffers)
- Noise Filter to Remove Noise 50 ns or less
- Seven- and Ten-Bit Device Addressing Modes
- Master (Transmit/Receive) and Slave (Transmit/Receive) Functionality
- Events: DMA, Interrupt, or Polling
- Slew-Rate Limited Open-Drain Output Buffers

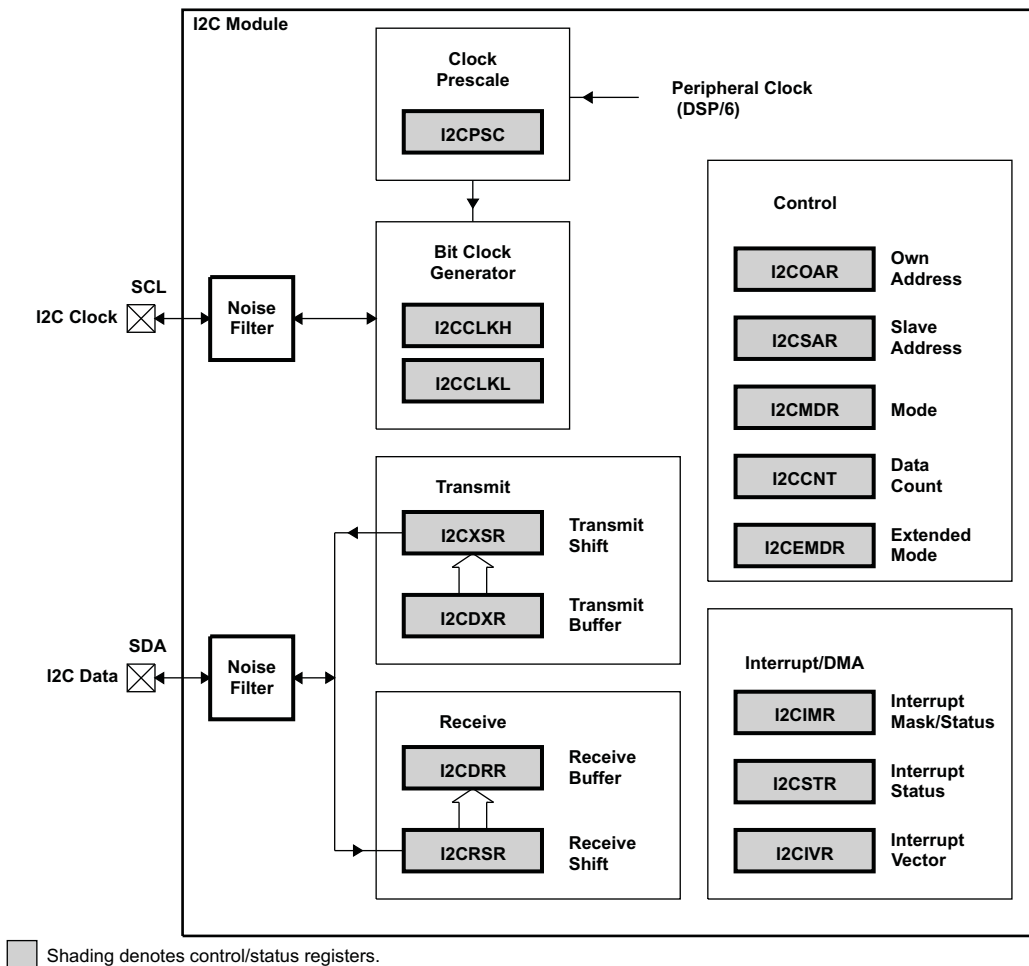

Figure 6-37. I2C Module Block Diagram

For more detailed information on the I2C peripheral, see the *TMS320DM647/DM648 DSP Inter-Integrated Circuit (I2C) Module User's Guide* (literature number [SPRUEK8](#)).

6.15.1 I2C Peripheral Register Description(s)

Table 6-62. I2C Registers

HEX ADDRESS RANGE	ACRONYM	REGISTER NAME
0x0204 7C00	ICOAR	I2C Own Address Register
0x0204 7C04	ICIMR	I2C Interrupt Mask Register
0x0204 7C08	ICSTR	I2C Interrupt Status Register
0x0204 7C0C	ICCLKL	I2C Clock Divider Low Register
0x0204 7C10	ICCLKH	I2C Clock Divider High Register
0x0204 7C14	ICCNT	I2C Data Count Register
0x0204 7C18	ICDRR	I2C Data Receive Register
0x0204 7C1C	ICSAR	I2C Slave Address Register
0x0204 7C20	ICDXR	I2C Data Transmit Register
0x0204 7C24	ICMDR	I2C Mode Register
0x0204 7C28	ICIVR	I2C Interrupt Vector Register
0x0204 7C2C	ICEMDR	I2C Extended Mode Register
0x0204 7C30	ICPSC	I2C Prescaler Register
0x0204 7C34	ICDMAC	I2C DMA Control Register

6.15.2 I2C Electrical Data/Timing

6.15.2.1 Inter-Integrated Circuits (I2C) Timing

Table 6-63. Timing Requirements for I2C Timings⁽¹⁾ (see Figure 6-38)

NO.			720, 800, 900, 1100				UNIT
			STANDARD MODE		FAST MODE		
			MIN	MAX	MIN	MAX	
1	$t_{c(SCL)}$	Cycle time, SCL	10		2.5		μ s
2	$t_{su(SCLH-SDAL)}$	Setup time, SCL high before SDA low (for a repeated START condition)	4.7		0.6		μ s
3	$t_h(SCLL-SDAL)$	Hold time, SCL low after SDA low (for a START and a repeated START condition)	4		0.6		μ s
4	$t_w(SCLL)$	Pulse duration, SCL low	4.7		1.3		μ s
5	$t_w(SCLH)$	Pulse duration, SCL high	4		0.6		μ s
6	$t_{su(SDAV-SCLH)}$	Setup time, SDA valid before SCL high	250		100 ⁽²⁾		ns
7	$t_h(SDA-SCLL)$	Hold time, SDA valid after SCL low	0 ⁽³⁾		0 ⁽³⁾	0.9 ⁽⁴⁾	μ s
8	$t_w(SDAH)$	Pulse duration, SDA high between STOP and START conditions	4.7		1.3		μ s
9	$t_r(SDA)$	Rise time, SDA	1000		$20 + 0.1C_b$ ⁽⁵⁾	300	ns
10	$t_r(SCL)$	Rise time, SCL	1000		$20 + 0.1C_b$ ⁽⁵⁾	300	ns
11	$t_f(SDA)$	Fall time, SDA	300		$20 + 0.1C_b$ ⁽⁵⁾	300	ns
12	$t_f(SCL)$	Fall time, SCL	300		$20 + 0.1C_b$ ⁽⁵⁾	300	ns
13	$t_{su(SCLH-SDAH)}$	Setup time, SCL high before SDA high (for STOP condition)	4		0.6		μ s
14	$t_w(SP)$	Pulse duration, spike (must be suppressed)			0	50	ns
15	C_b ⁽⁵⁾	Capacitive load for each bus line	400			400	pF

- (1) The I2C pins SDA and SCL do not feature fail-safe I/O buffers. These pins could potentially draw current when the device is powered down.
- (2) A Fast-mode I2C-bus™ device can be used in a standard-mode I2C-bus system, but the requirement $t_{su(SDA-SCLH)} \geq 250$ ns must then be met. This will be the case automatically if the device does not stretch the LOW period of the SCL signal. If such a device does stretch the LOW period of the SCL signal, it must output the next data bit to the SDA line t_r max + $t_{su(SDA-SCLH)} = 1000 + 250 = 1250$ ns (according to the Standard-mode I2C-Bus Specification) before the SCL line is released.
- (3) A device must internally provide a hold time of at least 300 ns for the SDA signal (referred to the V_{IHmin} of the SCL signal) to bridge the undefined region of the falling edge of SCL.
- (4) The maximum $t_h(SDA-SCLL)$ has to be met only if the device does not stretch the low period [$t_w(SCLL)$] of the SCL signal.
- (5) C_b = total capacitance of one bus line in pF. If mixed with HS-mode devices, faster fall-times are allowed.

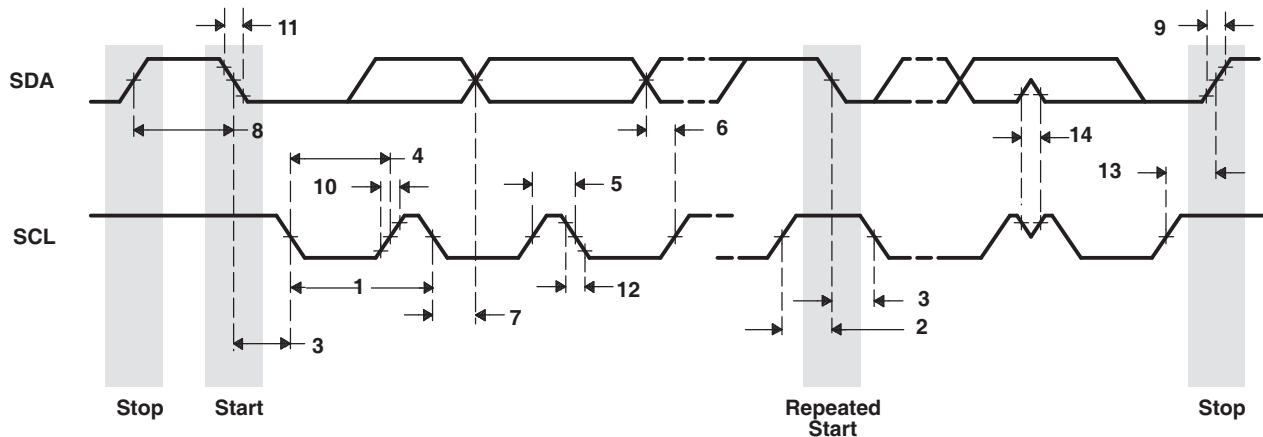

Figure 6-38. I2C Receive Timings

Table 6-64. Switching Characteristics for I2C Timings⁽¹⁾ (see Figure 6-39)

NO.	PARAMETER	720, 800, 900, 1100				UNIT
		STANDARD MODE		FAST MODE		
		MIN	MAX	MIN	MAX	
16	$t_{c(SCL)}$ Cycle time, SCL	10		2.5		μs
17	$t_{d(SCLH-SDAL)}$ Delay time, SCL high to SDA low (for a repeated START condition)	4.7		0.6		μs
18	$t_{d(SDAL-SCLL)}$ Delay time, SDA low to SCL low (for a START and a repeated START condition)	4		0.6		μs
19	$t_{w(SCLL)}$ Pulse duration, SCL low	4.7		1.3		μs
20	$t_{w(SCLH)}$ Pulse duration, SCL high	4		0.6		μs
21	$t_{d(SDAV-SCLH)}$ Delay time, SDA valid to SCL high	250		100		ns
22	$t_{v(SCLL-SDAV)}$ Valid time, SDA valid after SCL low	0		0	0.9	μs
23	$t_{w(SDAH)}$ Pulse duration, SDA high between STOP and START conditions	4.7		1.3		μs
24	$t_{r(SDA)}$ Rise time, SDA	1000		$20 + 0.1C_b^{(2)}$	300	ns
25	$t_{r(SCL)}$ Rise time, SCL	1000		$20 + 0.1C_b^{(2)}$	300	ns
26	$t_{f(SDA)}$ Fall time, SDA	300		$20 + 0.1C_b^{(2)}$	300	ns
27	$t_{f(SCL)}$ Fall time, SCL	300		$20 + 0.1C_b^{(2)}$	300	ns
28	$t_{d(SCLH-SDAH)}$ Delay time, SCL high to SDA high (for STOP condition)	4		0.6		μs
29	C_p Capacitance for each I2C pin	10		10		pF

(1) C_b = total capacitance of one bus line in pF. If mixed with HS-mode devices, faster fall-times are allowed.

(2) C_b = total capacitance of one bus line in pF. If mixed with HS-mode devices, faster fall-times are allowed.

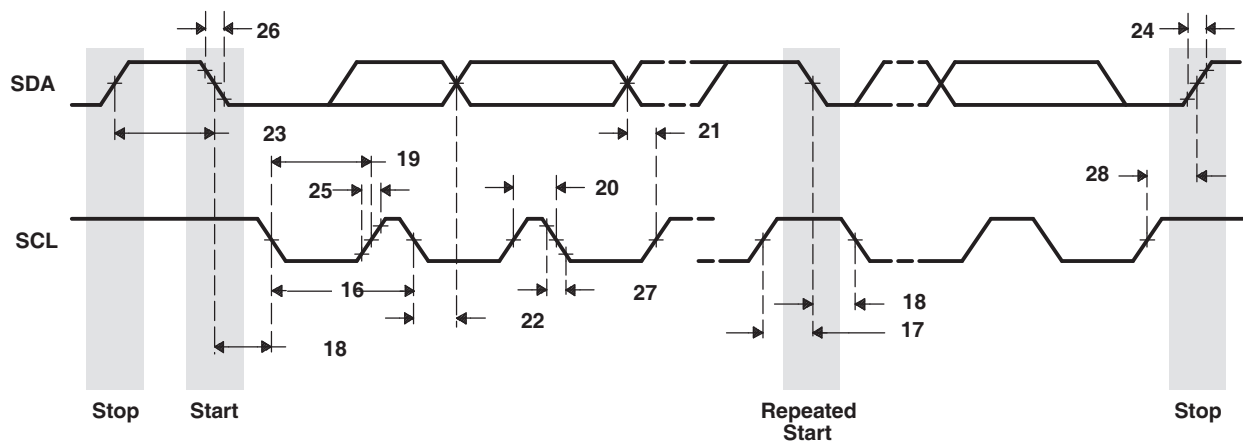

Figure 6-39. I2C Transmit Timings

6.16 Host-Port Interface (HPI) Peripheral

6.16.1 HPI Device-Specific Information

The device includes a user-configurable 16-bit or 32-bit host-port interface (HPI16/HPI32). The AEA14 pin controls the HPI_WIDTH, allowing the user to configure the HPI as a 16-bit or 32-bit peripheral.

Software handshaking via the HRDY bit of the Host Port Control Register (HPIC) is not supported.

An HPI boot is terminated using a DSP interrupt. The DSP interrupt is registered in bit 0 (channel 0) of the EDMA Event Register (ER). This event must be cleared by software before triggering transfers on DMA channel 0.

6.16.2 HPI Peripheral Register Description(s)

Table 6-65. HPI Control Registers

HEX ADDRESS RANGE	ACRONYM	REGISTER NAME	COMMENTS
0x0200 0000	PID	Peripheral Identification Register	
0x0200 0004	PWREMU_MGMT	HPI power and emulation management register	PWREMU_MGMT has both host/CPU read/write access.
0x0200 0008 - 0x0200 0024	-	Reserved	
0x0200 0028	-	Reserved	
0x0200 002C	-	Reserved	
0x0200 0030	HPIC	HPI control register	The host and the CPU have read/write access to the HPIC register. ⁽¹⁾
0x0200 0034	HPIA (HPIAW) ⁽²⁾	HPI address register (Write)	The host has read/write access to the HPIA registers. The CPU has read access only to the HPIA registers.
0x0200 0038	HPIA (HPIAR) ⁽²⁾	HPI address register (Read)	
0x0200 003C - 0x0200 007F	-	Reserved	

- (1) The CPU can write 1 to the $\overline{\text{HINT}}$ bit to generate an interrupt to the host and it can write 1 to the DSPINT bit to clear/acknowledge an interrupt from the host.
- (2) There are two 32-bit HPIA registers: HPIAR for read operations and HPIAW for write operations. The HPI can be configured such that HPIAR and HPIAW act as a single 32-bit HPIA (single-HPIA mode) or as two separate 32-bit HPIAs (dual-HPIA mode) from the perspective of the host. The CPU can access HPIAW and HPIAR independently. For details about the HPIA registers and their modes, see the *TMS320DM647/DM648 DSP Host Port Interface (HPI) User's Guide* (literature number [SPRUEL5](#)).

6.16.3 HPI Electrical Data/Timing

Table 6-66. Timing Requirements for Host-Port Interface Cycles⁽¹⁾ ⁽²⁾ (see [Figure 6-40](#) through [Figure 6-47](#))

NO.		720, 800, 900, 1100		UNIT
		MIN	MAX	
9	$t_{su}(HASL-HSTBL)$ Setup time, \overline{HAS} low before $\overline{HSTROBE}$ low	5		ns
10	$t_h(HSTBL-HASL)$ Hold time, \overline{HAS} low after $\overline{HSTROBE}$ low	2		ns
11	$t_{su}(SELV-HASL)$ Setup time, select signals ⁽³⁾ valid before \overline{HAS} low	5		ns
12	$t_h(HASL-SELV)$ Hold time, select signals ⁽³⁾ valid after \overline{HAS} low	5		ns
13	$t_w(HSTBL)$ Pulse duration, $\overline{HSTROBE}$ low	2M		ns
14	$t_w(HSTBH)$ Pulse duration, $\overline{HSTROBE}$ high between consecutive accesses	2M		ns
15	$t_{su}(SELV-HSTBL)$ Setup time, select signals ⁽³⁾ valid before $\overline{HSTROBE}$ low	5		ns
16	$t_h(HSTBL-SELV)$ Hold time, select signals ⁽³⁾ valid after $\overline{HSTROBE}$ low	5		ns
17	$t_{su}(HDV-HSTBH)$ Setup time, host data valid before $\overline{HSTROBE}$ high	5		ns
18	$t_h(HSTBH-HDV)$ Hold time, host data valid after $\overline{HSTROBE}$ high	1		ns
37	$t_{su}(HCSSL-HSTBL)$ Setup time, \overline{HCS} low before $\overline{HSTROBE}$ low	0		ns
38	$t_h(HRDYL-HSTBL)$ Hold time, $\overline{HSTROBE}$ low after \overline{HRDY} low. $\overline{HSTROBE}$ should not be inactivated until \overline{HRDY} is active (low); otherwise, HPI writes will not complete properly.	1.1		ns

(1) $\overline{HSTROBE}$ refers to the following logical operation on \overline{HCS} , $\overline{HDS1}$, and $\overline{HDS2}$: $[\text{NOT}(\overline{HDS1} \text{ XOR } \overline{HDS2})] \text{ OR } \overline{HCS}$.

(2) $M = \text{SYSCLK3 period} = 6/\text{CPU clock frequency in ns}$.

(3) Select signals include: $\overline{HCNTL}[1:0]$ and $\overline{HR/W}$. For HPI16 mode only, select signals also include \overline{HHWIL} .

Table 6-67. Switching Characteristics for Host-Port Interface Cycles^{(1) (2)}
(see [Figure 6-40](#) through [Figure 6-47](#))

NO.	PARAMETER		720, 800, 900, 1100		UNIT	
			MIN	MAX		
1	$t_{d(HSTBL-HDV)}$	Delay time, $\overline{HSTROBE}$ low to DSP data valid	Case 1. HPIC or HPIA read	5	15	ns
			Case 2. HPID read with no auto-increment ⁽³⁾	9 × M + 20		
			Case 3. HPID read with auto-increment and read FIFO initially empty ⁽³⁾	9 × M + 20		
			Case 4. HPID read with auto-increment and data previously prefetched into the read FIFO	5	15	
2	$t_{dis(HSTBH-HDV)}$	Disable time, HD high-impedance from $\overline{HSTROBE}$ high	1	4	ns	
3	$t_{en(HSTBL-HD)}$	Enable time, HD driven from $\overline{HSTROBE}$ low	3	15	ns	
4	$t_{d(HSTBL-HRDYH)}$	Delay time, $\overline{HSTROBE}$ low to \overline{HRDY} high		12	ns	
5	$t_{d(HSTBH-HRDYH)}$	Delay time, $\overline{HSTROBE}$ high to \overline{HRDY} high		12	ns	
6	$t_{d(HSTBL-HRDYL)}$	Delay time, $\overline{HSTROBE}$ low to \overline{HRDY} low	Case 1. HPID read with no auto-increment ⁽³⁾	10 × M + 20		ns
			Case 2. HPID read with auto-increment and read FIFO initially empty ⁽³⁾	10 × M + 20		
7	$t_{d(HDV-HRDYL)}$	Delay time, HD valid to \overline{HRDY} low	0		ns	
34	$t_{d(DSH-HRDYL)}$	Delay time, $\overline{HSTROBE}$ high to \overline{HRDY} low	Case 1. HPIA write ⁽³⁾	5 × M + 20		ns
			Case 2. HPID write with no auto-increment ⁽³⁾	5 × M + 20		
35	$t_{d(HSTBL-HRDYL)}$	Delay time, $\overline{HSTROBE}$ low to \overline{HRDY} low for HPIA write and FIFO not empty ⁽³⁾		40 × M + 20		ns
36	$t_{d(HASL-HRDYH)}$	Delay time, \overline{HAS} low to \overline{HRDY} high		12	ns	

- (1) M = SYSCLK3 period = 6/CPU clock frequency in ns.
- (2) $\overline{HSTROBE}$ refers to the following logical operation on \overline{HCS} , $\overline{HDS1}$, and $\overline{HDS2}$: $[\text{NOT}(\overline{HDS1} \text{ XOR } \overline{HDS2})] \text{ OR } \overline{HCS}$.
- (3) Assumes the HPI is accessing L2/L1 memory and no other master is accessing the same memory location.

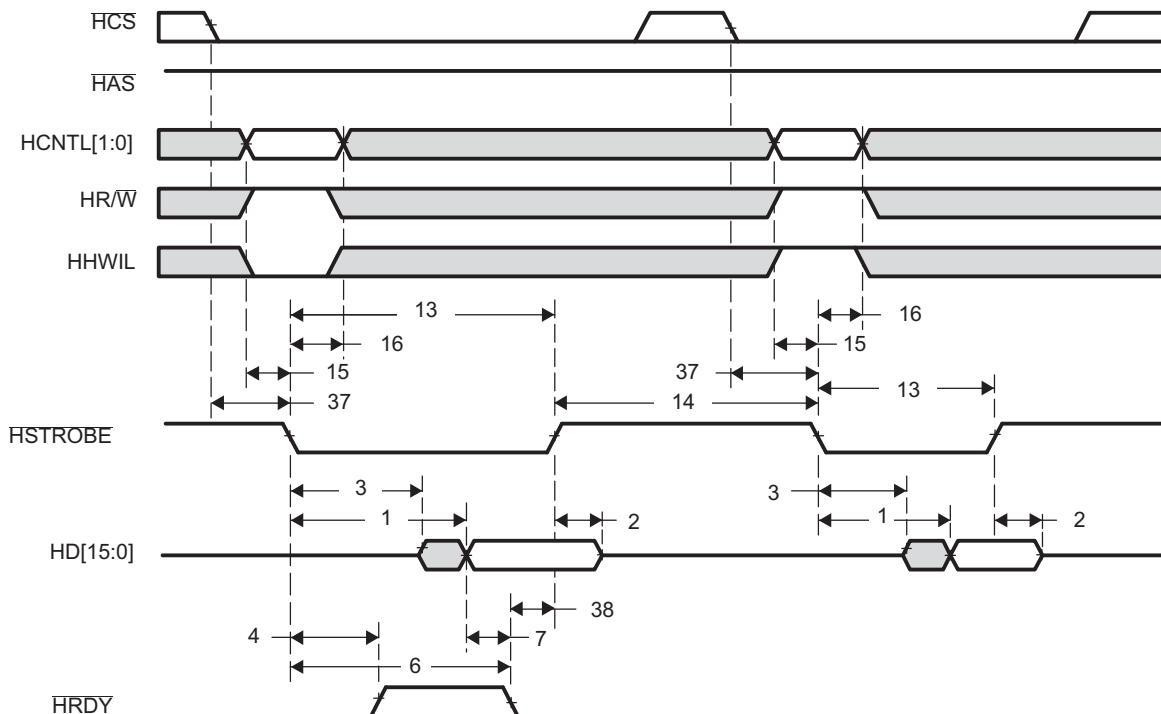

- A. $\overline{\text{HSTROBE}}$ refers to the following logical operation on $\overline{\text{HCS}}$, $\overline{\text{HDS1}}$, and $\overline{\text{HDS2}}$: $[\text{NOT}(\overline{\text{HDS1}} \text{ XOR } \overline{\text{HDS2}})] \text{ OR } \overline{\text{HCS}}$.
- B. Depending on the type of write or read operation (HPID without auto-incrementing; HPIA, HPIC, or HPID with auto-incrementing) and the state of the FIFO, transitions on $\overline{\text{HRDY}}$ may or may not occur. For more detailed information on the HPI peripheral, see the *TMS320DM647/DM648 DSP Host Port Interface (HPI) User's Guide* (literature number [SPRUUEL5](#)).

Figure 6-40. HPI16 Read Timing ($\overline{\text{HAS}}$ Not Used, Tied High)

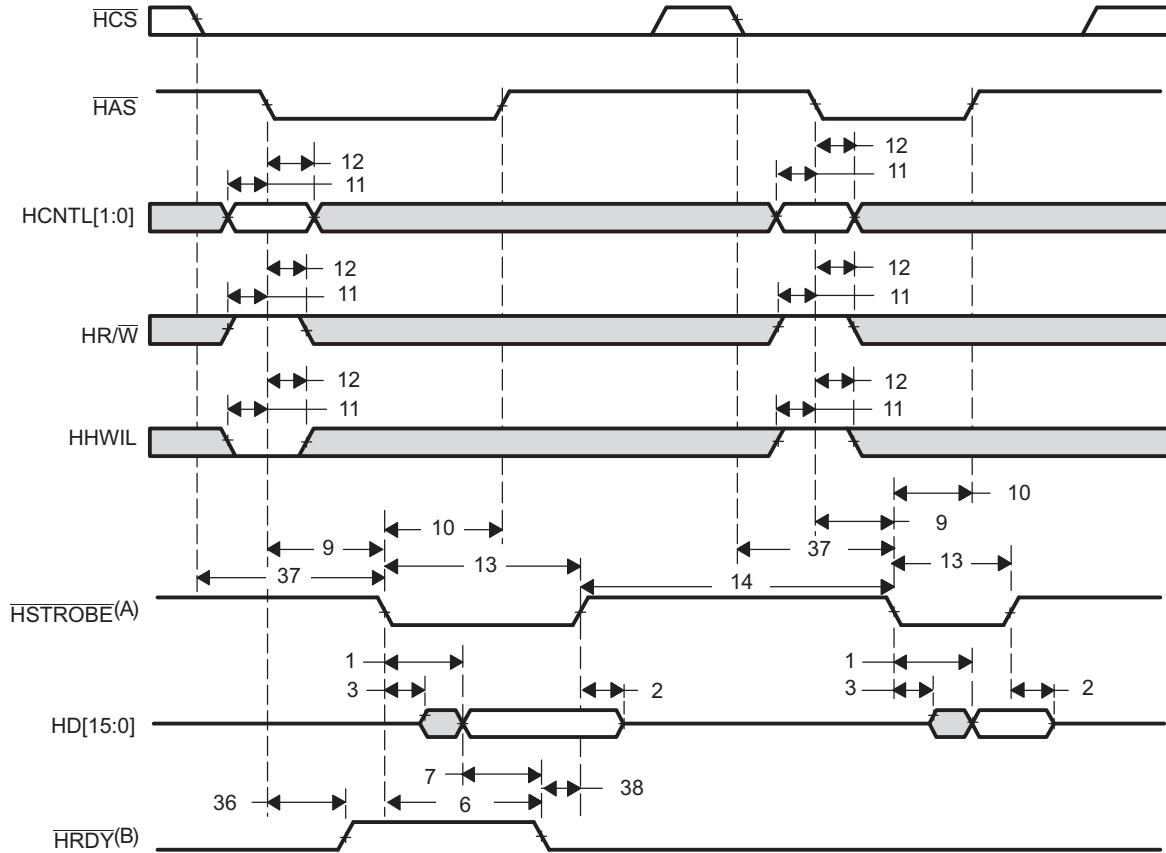

- A. $\overline{\text{HSTROBE}}$ refers to the following logical operation on $\overline{\text{HCS}}$, $\overline{\text{HDS1}}$, and $\overline{\text{HDS2}}$: $[\text{NOT}(\overline{\text{HDS1}} \text{ XOR } \overline{\text{HDS2}})] \text{ OR } \overline{\text{HCS}}$.
- B. Depending on the type of write or read operation (HPID without auto-incrementing; HPIA, HPIC, or HPID with auto-incrementing) and the state of the FIFO, transitions on $\overline{\text{HRDY}}$ may or may not occur. For more detailed information on the HPI peripheral, see the *TMS320DM647/DM648 DSP Host Port Interface (HPI) User's Guide* (literature number [SPRUEL5](#)).

Figure 6-41. HPI16 Read Timing ($\overline{\text{HAS}}$ Used)

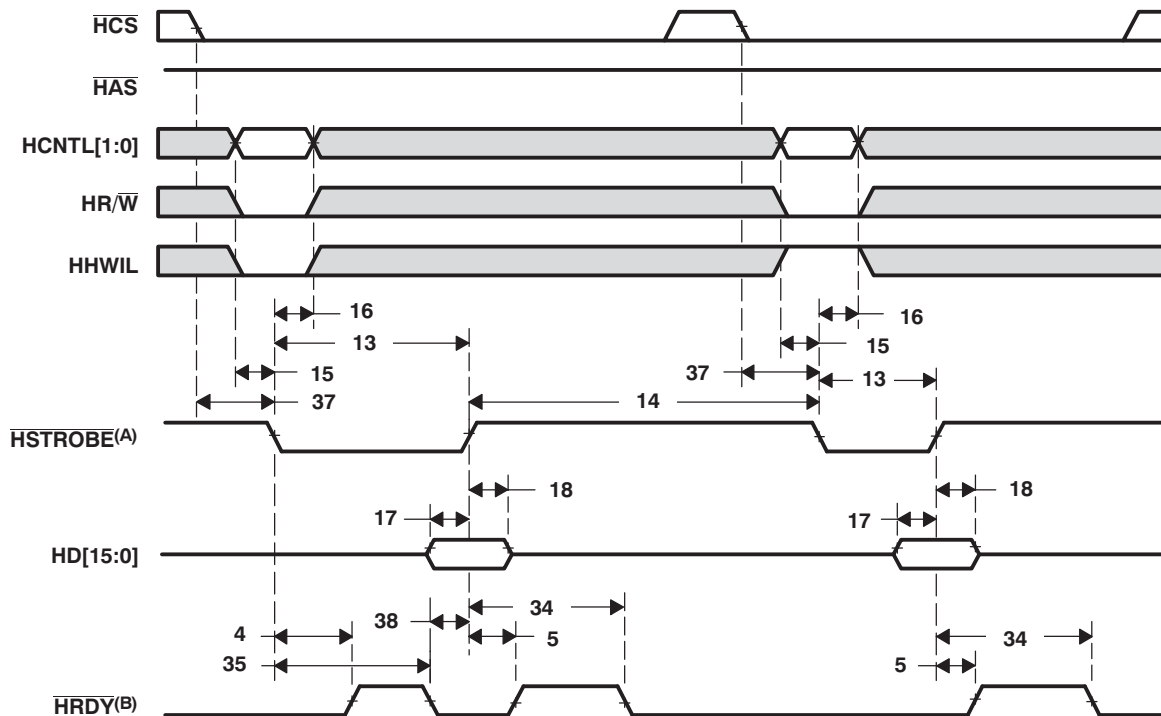

- A. $\overline{HSTROBE}^{(A)}$ refers to the following logical operation on \overline{HCS} , $\overline{HDS1}$, and $\overline{HDS2}$: $[\text{NOT}(\overline{HDS1} \text{ XOR } \overline{HDS2})] \text{ OR } \overline{HCS}$.
- B. Depending on the type of write or read operation (HPID without auto-incrementing; HPIA, HPIC, or HPID with auto-incrementing) and the state of the FIFO, transitions on $\overline{HRDY}^{(B)}$ may or may not occur. For more detailed information on the HPI peripheral, see the *TMS320DM647/DM648 DSP Host Port Interface (HPI) User's Guide* (literature number [SPRUEL5](#)).

Figure 6-42. HPI16 Write Timing (\overline{HAS} Not Used, Tied High)

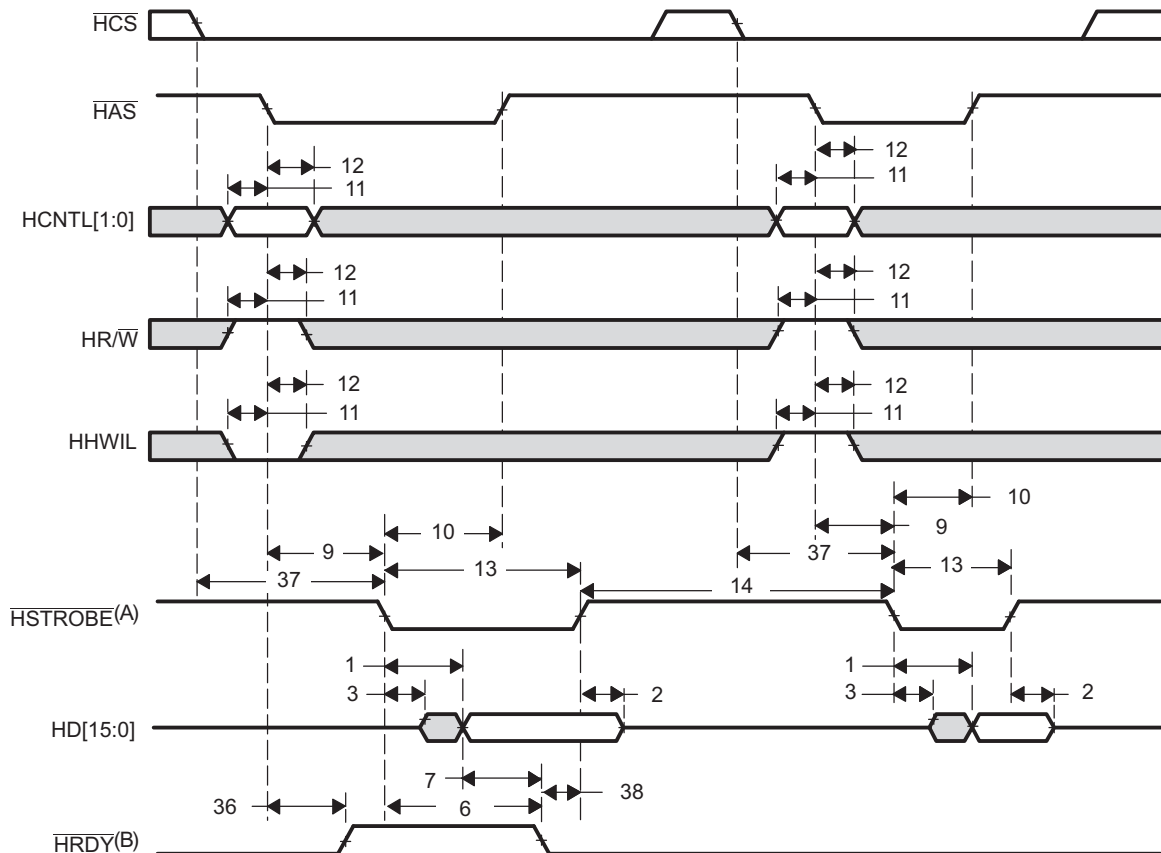

- A. $\overline{\text{HSTROBE}}$ refers to the following logical operation on $\overline{\text{HCS}}$, $\overline{\text{HDS1}}$, and $\overline{\text{HDS2}}$: $[\text{NOT}(\overline{\text{HDS1}} \text{ XOR } \overline{\text{HDS2}})] \text{ OR } \overline{\text{HCS}}$.
- B. Depending on the type of write or read operation (HPID without auto-incrementing; HPIA, HPIC, or HPID with auto-incrementing) and the state of the FIFO, transitions on $\overline{\text{HRDY}}$ may or may not occur. For more detailed information on the HPI peripheral, see the *TMS320DM647/DM648 DSP Host Port Interface (HPI) User's Guide* (literature number [SPRUEL5](#)).

Figure 6-43. HPI16 Write Timing ($\overline{\text{HAS}}$ Used)

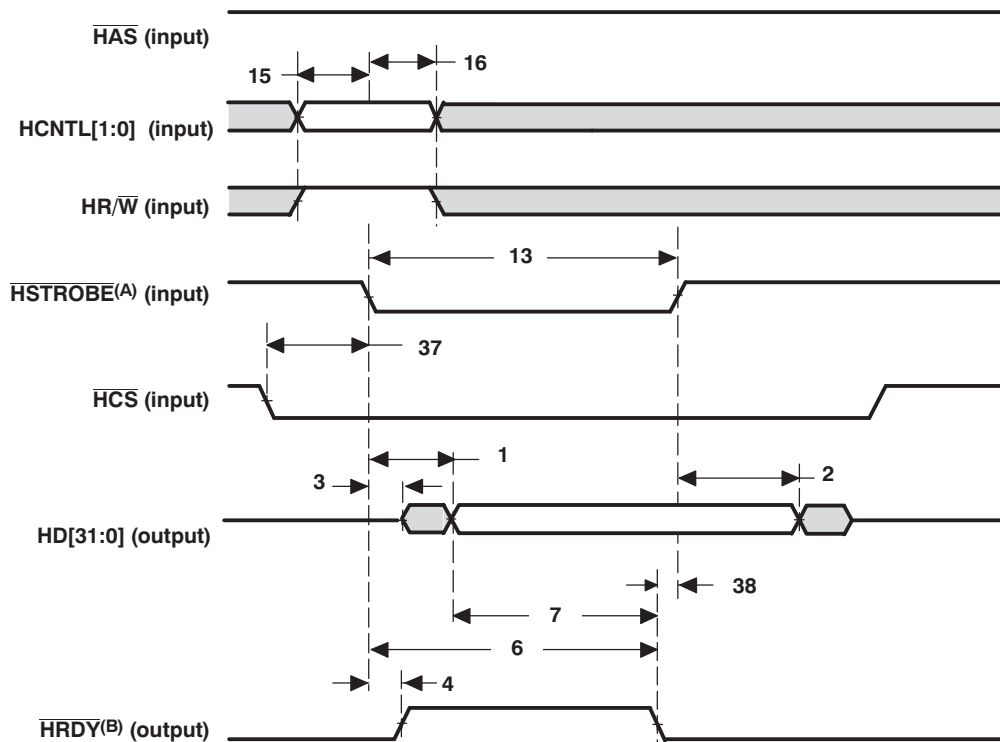

- A. $\overline{\text{HSTROBE}}$ refers to the following logical operation on $\overline{\text{HCS}}$, $\overline{\text{HDS1}}$, and $\overline{\text{HDS2}}$: $[\text{NOT}(\overline{\text{HDS1}} \text{ XOR } \overline{\text{HDS2}})] \text{ OR } \overline{\text{HCS}}$.
- B. Depending on the type of write or read operation (HPID without auto-incrementing; HPIA, HPIC, or HPID with auto-incrementing) and the state of the FIFO, transitions on $\overline{\text{HRDY}}$ may or may not occur. For more detailed information on the HPI peripheral, see the *TMS320DM647/DM648 DSP Host Port Interface (HPI) User's Guide* (literature number [SPRUJEL5](#))

Figure 6-44. HPI32 Read Timing ($\overline{\text{HAS}}$ Not Used, Tied High)

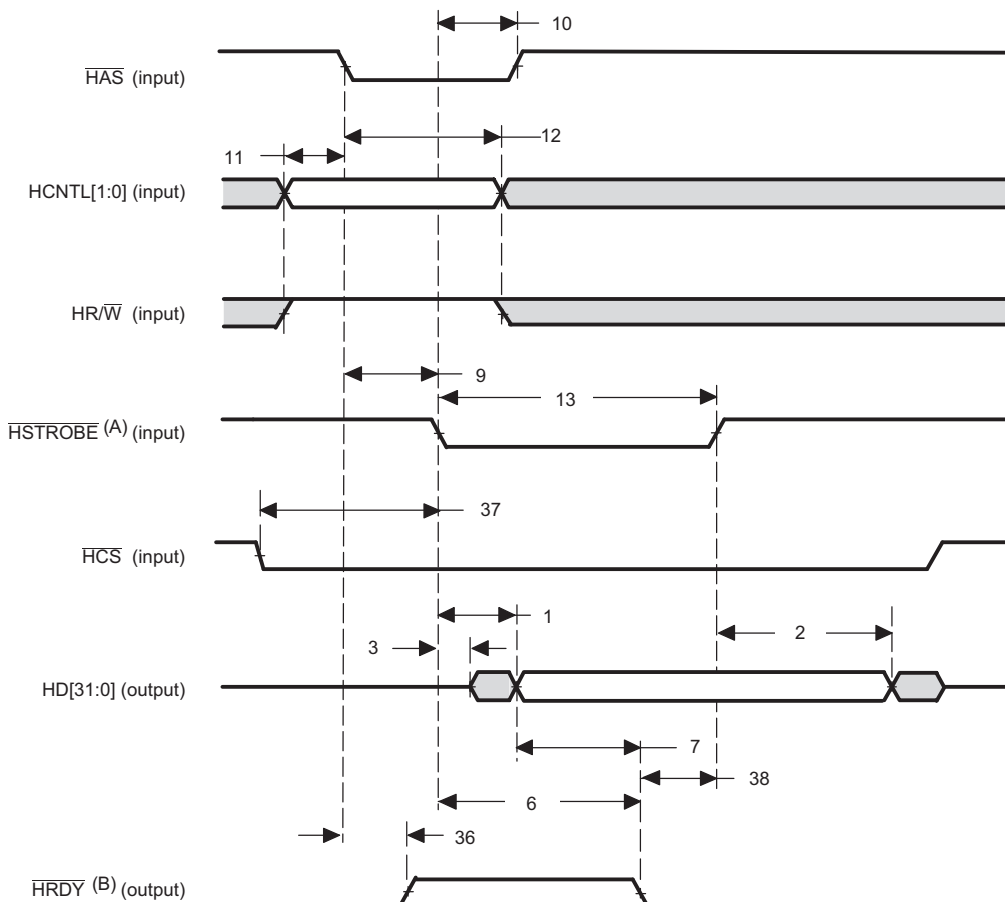

- A. $\overline{\text{HSTROBE}}$ refers to the following logical operation on $\overline{\text{HCS}}$, $\overline{\text{HDS1}}$, and $\overline{\text{HDS2}}$: $[\text{NOT} (\overline{\text{HDS1}} \text{ XOR } \overline{\text{HDS2}})] \text{ OR } \overline{\text{HCS}}$.
- B. Depending on the type of write or read operation (HPID without auto-incrementing; HPIA, HPIC, or HPID with auto-incrementing) and the state of the FIFO, transitions on $\overline{\text{HRDY}}$ may or may not occur. For more detailed information on the HPI peripheral, see the *TMS320DM647/DM648 DSP Host Port Interface (HPI) User's Guide* (literature number [SPRUEL5](#))

Figure 6-45. HPI32 Read Timing ($\overline{\text{HAS}}$ Used)

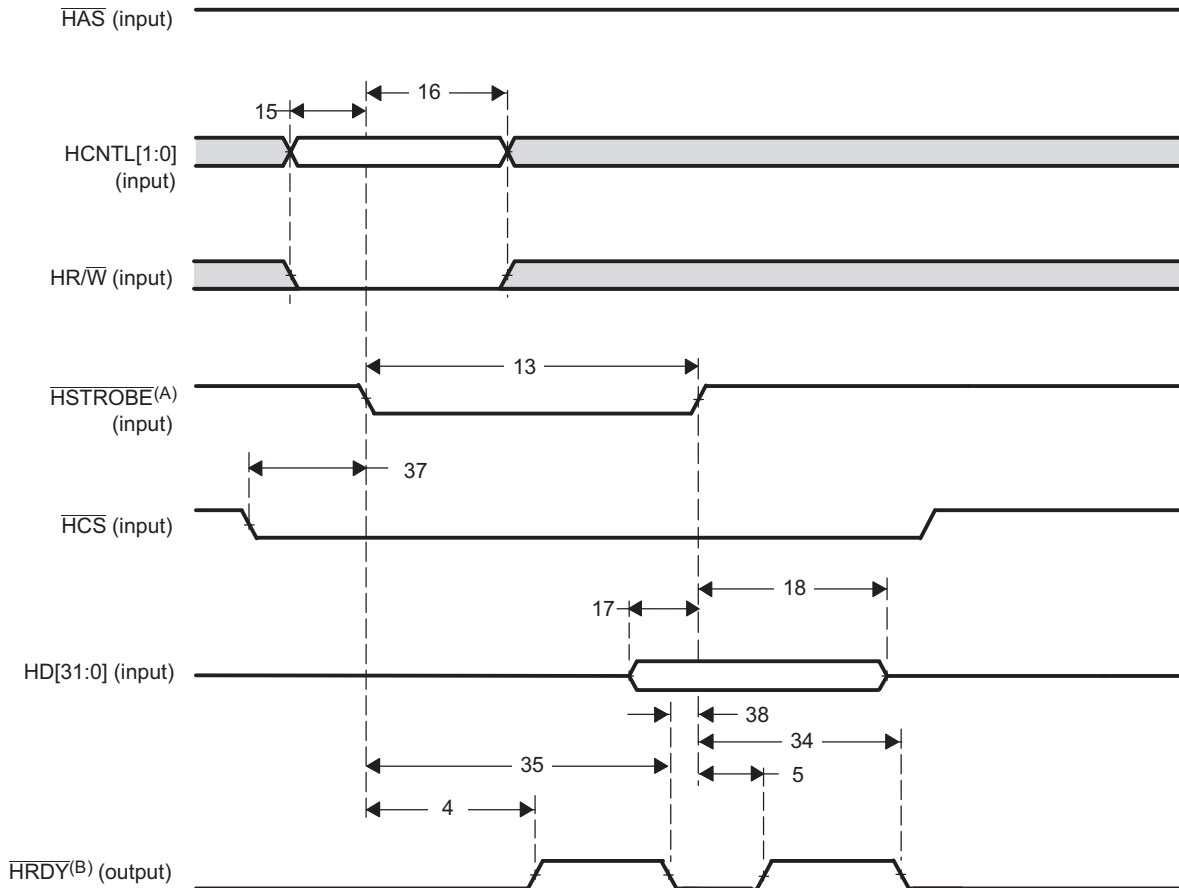

- A. $\overline{\text{HSTROBE}}$ refers to the following logical operation on $\overline{\text{HCS}}$, $\overline{\text{HDS1}}$, and $\overline{\text{HDS2}}$: $[\text{NOT } (\overline{\text{HDS1}} \text{ XOR } \overline{\text{HDS2}})] \text{ OR } \overline{\text{HCS}}$.
- B. Depending on the type of write or read operation (HPID without auto-incrementing; HPIA, HPIC, or HPID with auto-incrementing) and the state of the FIFO, transitions on $\overline{\text{HRDY}}$ may or may not occur. For more detailed information on the HPI peripheral, see the *TMS320DM647/DM648 DSP Host Port Interface (HPI) User's Guide* (literature number [SPRUUEL5](#))

Figure 6-46. HPI32 Write Timing ($\overline{\text{HAS}}$ Not Used, Tied High)

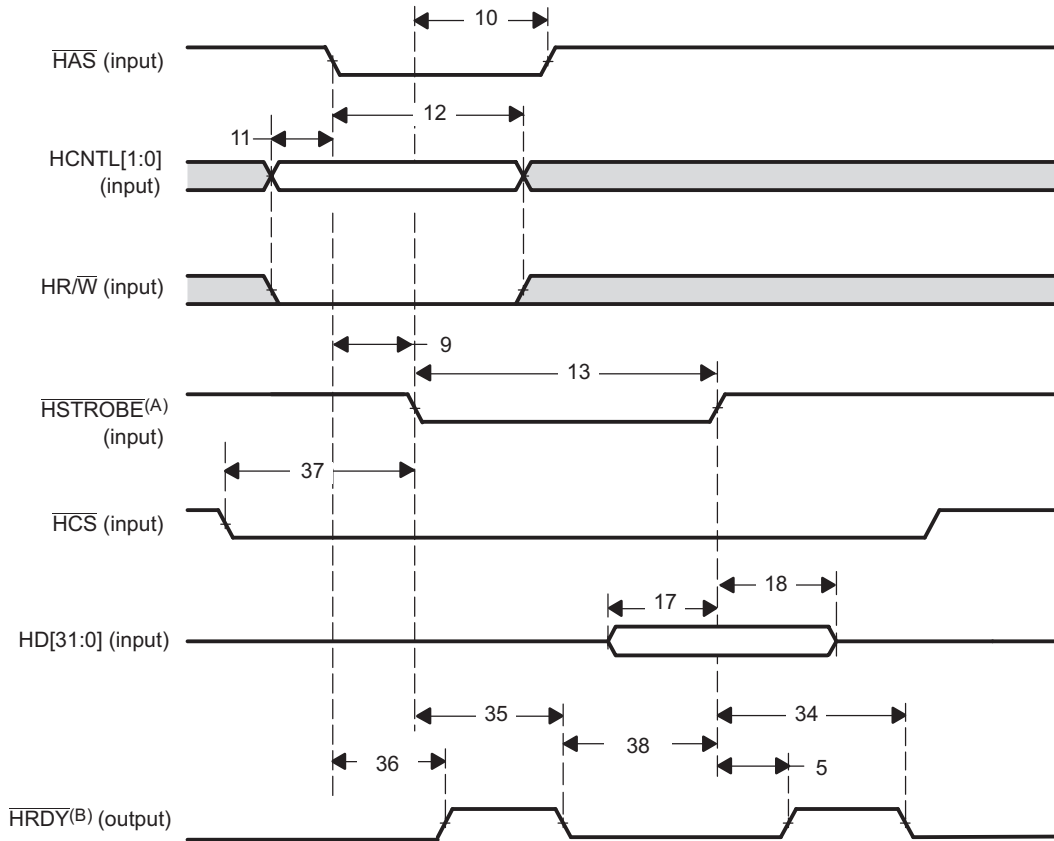

- A. $\overline{\text{HSTROBE}}$ refers to the following logical operation on $\overline{\text{HCS}}$, $\overline{\text{HDS1}}$, and $\overline{\text{HDS2}}$: $[\text{NOT}(\overline{\text{HDS1}} \text{ XOR } \overline{\text{HDS2}})] \text{ OR } \overline{\text{HCS}}$.
- B. Depending on the type of write or read operation (HPID without auto-incrementing; HPIA, HPIC, or HPID with auto-incrementing) and the state of the FIFO, transitions on $\overline{\text{HRDY}}$ may or may not occur. For more detailed information on the HPI peripheral, see the *TMS320DM647/DM648 DSP Host Port Interface (HPI) User's Guide* (literature number [SPRUEL5](#))

Figure 6-47. HPI32 Write Timing ($\overline{\text{HAS}}$ Used)

6.17 Peripheral Component Interconnect (PCI)

The device supports connections to a PCI backplane via the integrated PCI master/slave bus interface. The PCI port interfaces to DSP internal resources via the data switched central resource. .

For more detailed information on the PCI port peripheral module, see the *TMS320DM647/DM648 Peripheral Component Interconnect (PCI) User's Guide* (literature number [SPRUJEL4](#)).

6.17.1 PCI Device-Specific Information

The PCI peripheral conforms to the *PCI Local Bus Specification* (version 2.3). The PCI peripheral can act both as a PCI bus master and as a target. It supports PCI bus operation of speeds up to 66 MHz and uses a 32-bit data/address bus.

The pins of the PCI peripheral are multiplexed with the pins of the HPI, and GPIO peripherals. PCI functionality for these pins is controlled (enabled/disabled) by the UHPIEN pin (H2). The maximum speed of the PCI, 33 MHz or 66 MHz, is controlled through the PCI66 pin (G5). For more detailed information on the peripheral control, see [Section 3](#).

The device provides an initialization mechanism through which the default values for some of the PCI configuration registers can be read from an I2C EEPROM. [Table 6-68](#) shows the registers which can be initialized through the PCI auto-initialization. Also shown is the default value of these registers when PCI auto-initialization is not used. PCI auto-initialization is enabled by selecting PCI boot with auto-initialization. For more information on this feature, see the *TMS320DM647/DM648 Peripheral Component Interconnect (PCI) User's Guide* (literature number [SPRUJEL4](#)) and the *Using the TMS320DM647/DM648 Bootloader* Application Report (literature number [SPRAAJ1](#)).

Table 6-68. Default Values for PCI Configuration Registers

REGISTER	DEFAULT VALUE
Vendor ID/Device ID Register (PCIVENDEV)	104C B003h
Class Code/Revision ID Register (PCICLREV)	0000 0001h
Subsystem Vendor ID/Subsystem ID Register (PCISUBID)	0000 0000h
Max Latency/Min Grant/Interrupt Pin/Interrupt Line Register (PCILGINT)	0000 0100h

6.17.2 PCI Peripheral Register Description(s)

Table 6-69. PCI Configuration Registers

PCI HOST ACCESS HEX ADDRESS OFFSET	ACRONYM	PCI HOST ACCESS REGISTER NAME
0x00	PCIVENDEV	Vendor ID/Device ID
0x04	PCICSR	Command/Status
0x08	PCICLREV	Class Code/Revision ID
0x0C	PCICLINE	BIST/Header Type/Latency Timer/Cacheline Size
0x10	PCIBAR0	Base Address 0
0x14	PCIBAR1	Base Address 1
0x18	PCIBAR2	Base Address 2
0x1C	PCIBAR3	Base Address 3
0x20	PCIBAR4	Base Address 4
0x24	PCIBAR5	Base Address 5
0x28 - 0x2B	-	Reserved
0x2C	PCISUBID	Subsystem Vendor ID/Subsystem ID
0x30	-	Reserved
0x34	PCICBPTR	Capabilities Pointer
0x38 - 0x3B	-	Reserved
0x3C	PCILGINT	Max Latency/Min Grant/Interrupt Pin/Interrupt Line
0x40 - 0x7F	-	Reserved

Table 6-70. PCI Back End Configuration Registers

DSP ACCESS HEX ADDRESS RANGE	ACRONYM	DSP ACCESS REGISTER NAME
0x0204 8400 - 0x0204 840F	-	Reserved
0x0204 8410	PCISTATSET	PCI Status Set Register
0x0204 8414	PCISTATCLR	PCI Status Clear Register
0x0204 8418 - 0x0204 841F	-	Reserved
0x0204 8420	PCIHINTSET	PCI Host Interrupt Enable Set Register
0x0204 8424	PCIHINTCLR	PCI Host Interrupt Enable Clear Register
0x0204 8428 - 0x0204 842F	-	Reserved
0x0204 8430	PCIBINTSET	PCI Back End Application Interrupt Enable Set Register
0x0204 8434	PCIBINTCLR	PCI Back End Application Interrupt Enable Clear Register
0x0204 8438	PCIBCLKMGT	PCI Back End Application Clock Management Register
0x0204 843C - 0x0204 84FF	-	Reserved
0x0204 8500	PCIVENDEVMIR	PCI Vendor ID/Device ID Mirror Register
0x0204 8504	PCICSRMIR	PCI Command/Status Mirror Register
0x0204 8508	PCICLREVMIR	PCI Class Code/Revision ID Mirror Register
0x0204 850C	PCICLINEMIR	PCI BIST/Header Type/Latency Timer/Cacheline Size Mirror Register
0x0204 8510	PCIBAR0MSK	PCI Base Address Mask Register 0
0x0204 8514	PCIBAR1MSK	PCI Base Address Mask Register 1
0x0204 8518	PCIBAR2MSK	PCI Base Address Mask Register 2
0x0204 851C	PCIBAR3MSK	PCI Base Address Mask Register 3
0x0204 8520	PCIBAR4MSK	PCI Base Address Mask Register 4
0x0204 8524	PCIBAR5MSK	PCI Base Address Mask Register 5
0x0204 8528 - 0x0204 852B	-	Reserved
0x0204 852C	PCISUBIDMIR	PCI Subsystem Vendor ID/Subsystem ID Mirror Register
0x0204 8530	-	Reserved

Table 6-70. PCI Back End Configuration Registers (continued)

DSP ACCESS HEX ADDRESS RANGE	ACRONYM	DSP ACCESS REGISTER NAME
0x0204 8534	PCICBPTRMIR	PCI Capabilities Pointer Mirror Register
0x0204 8538 - 0x0204 853B	-	Reserved
0x0204 853C	PCILGINTMIR	PCI Max Latency/Min Grant/Interrupt Pin/Interrupt Line Mirror Register
0x0204 8540 - 0x0204 857F	-	Reserved
0x0204 8580	PCISLVCNTL	PCI Slave Control Register
0x0204 8584 - 0x0204 85BF	-	Reserved
0x0204 85C0	PCIBAR0TRL	PCI Slave Base Address 0 Translation Register
0x0204 85C4	PCIBAR1TRL	PCI Slave Base Address 1 Translation Register
0x0204 85C8	PCIBAR2TRL	PCI Slave Base Address 2 Translation Register
0x0204 85CC	PCIBAR3TRL	PCI Slave Base Address 3 Translation Register
0x0204 85D0	PCIBAR4TRL	PCI Slave Base Address 4 Translation Register
0x0204 85D4	PCIBAR5TRL	PCI Slave Base Address 5 Translation Register
0x0204 85D8 - 0x0204 85DF	-	Reserved
0x0204 85E0	PCIBAR0MIR	PCI Base Address Register 0 Mirror Register
0x0204 85E4	PCIBAR1MIR	PCI Base Address Register 1 Mirror Register
0x0204 85E8	PCIBAR2MIR	PCI Base Address Register 2 Mirror Register
0x0204 85EC	PCIBAR3MIR	PCI Base Address Register 3 Mirror Register
0x0204 85F0	PCIBAR4MIR	PCI Base Address Register 4 Mirror Register
0x0204 85F4	PCIBAR5MIR	PCI Base Address Register 5 Mirror Register
0x0204 85F8 - 0x0204 86FF	-	Reserved
0x0204 8700	PCIMCFGDAT	PCI Master Configuration/IO Access Data Register
0x0204 8704	PCIMCFGADR	PCI Master Configuration/IO Access Address Register
0x0204 8708	PCIMCFGCMD	PCI Master Configuration/IO Access Command Register
0x0204 870C - 0x0204 870F	-	Reserved
0x0204 8710	PCIMSTCFG	PCI Master Configuration Register

Table 6-71. PCI Hook Configuration Registers

DSP ACCESS HEX ADDRESS RANGE	ACRONYM	DSP ACCESS REGISTER NAME
0x0204 8794	PCIVENDEVPRG	PCI Vendor ID and Device ID Program Register
0x0204 8798	PCICMDSTATPRG	PCI Command and Status Program Register
0x0204 879C	PCICLREVPGR	PCI Class Code and Revision ID Program Register
0x0204 87A0	PCISUBIDPRG	PCI Subsystem Vendor ID and Subsystem ID Program Register
0x0204 87A4	PCIMAXLGPRG	PCI Max Latency and Min Grant Program Register
0x0204 87A8	PCILRSTREG	PCI LRESET Register
0x0204 87AC	PCICFGDONE	PCI Configuration Done Register
0x0204 87B0	PCIBAR0MPRG	PCI Base Address Mask Register 0 Program Register
0x0204 87B4	PCIBAR1MPRG	PCI Base Address Mask Register 1 Program Register
0x0204 87B8	PCIBAR2MPRG	PCI Base Address Mask Register 2 Program Register
0x0204 87BC	PCIBAR3MPRG	PCI Base Address Mask Register 3 Program Register
0x0204 87C0	PCIBAR4MPRG	PCI Base Address Mask Register 4 Program Register
0x0204 87C4	PCIBAR5MPRG	PCI Base Address Mask Register 5 Program Register
0x0204 87C8	PCIBAR0PRG	PCI Base Address Register 0 Program Register
0x0204 87CC	PCIBAR1PRG	PCI Base Address Register 1 Program Register
0x0204 87D0	PCIBAR2PRG	PCI Base Address Register 2 Program Register
0x0204 87D4	PCIBAR3PRG	PCI Base Address Register 3 Program Register
0x0204 87D8	PCIBAR4PRG	PCI Base Address Register 4 Program Register

Table 6-71. PCI Hook Configuration Registers (continued)

DSP ACCESS HEX ADDRESS RANGE	ACRONYM	DSP ACCESS REGISTER NAME
0x0204 87DC	PCIBAR5PRG	PCI Base Address Register 5 Program Register
0x0204 87E0	PCIBAR0TRLPRG	PCI Base Address Translation Register 0 Program Register
0x0204 87E4	PCIBAR1TRLPRG	PCI Base Address Translation Register 1 Program Register
0x0204 87E8	PCIBAR2TRLPRG	PCI Base Address Translation Register 2 Program Register
0x0204 87EC	PCIBAR3TRLPRG	PCI Base Address Translation Register 3 Program Register
0x0204 87F0	PCIBAR4TRLPRG	PCI Base Address Translation Register 4 Program Register
0x0204 87F4	PCIBAR5TRLPRG	PCI Base Address Translation Register 5 Program Register
0x0204 87F8	PCIBASENPRG	PCI Base En Prog Register
0x0204 87FC - 0x0204 87FF	-	Reserved

Table 6-72. PCI External Memory Space

HEX ADDRESS OFFSET	ACRONYM	REGISTER NAME
0x4000 0000 - 0x407F FFFF	-	PCI Master Window 0
0x4080 0000 - 0x40FF FFFF	-	PCI Master Window 1
0x4100 0000 - 0x417F FFFF	-	PCI Master Window 2
0x4180 0000 - 0x41FF FFFF	-	PCI Master Window 3
0x4200 0000 - 0x427F FFFF	-	PCI Master Window 4
0x4280 0000 - 0x42FF FFFF	-	PCI Master Window 5
0x4300 0000 - 0x437F FFFF	-	PCI Master Window 6
0x4380 0000 - 0x43FF FFFF	-	PCI Master Window 7
0x4400 0000 - 0x447F FFFF	-	PCI Master Window 8
0x4480 0000 - 0x44FF FFFF	-	PCI Master Window 9
0x4500 0000 - 0x457F FFFF	-	PCI Master Window 10
0x4580 0000 - 0x45FF FFFF	-	PCI Master Window 11
0x4600 0000 - 0x467F FFFF	-	PCI Master Window 12
0x4680 0000 - 0x46FF FFFF	-	PCI Master Window 13
0x4700 0000 - 0x477F FFFF	-	PCI Master Window 14
0x4780 0000 - 0x47FF FFFF	-	PCI Master Window 15
0x4800 0000 - 0x487F FFFF	-	PCI Master Window 16
0x4880 0000 - 0x48FF FFFF	-	PCI Master Window 17
0x4900 0000 - 0x497F FFFF	-	PCI Master Window 18
0x4980 0000 - 0x49FF FFFF	-	PCI Master Window 19
0x4A00 0000 - 0x4A7F FFFF	-	PCI Master Window 20
0x4A80 0000 - 0x4AFF FFFF	-	PCI Master Window 21
0x4B00 0000 - 0x4B7F FFFF	-	PCI Master Window 22
0x4B80 0000 - 0x4BFF FFFF	-	PCI Master Window 23
0x4C00 0000 - 0x4C7F FFFF	-	PCI Master Window 24
0x4C80 0000 - 0x4CFF FFFF	-	PCI Master Window 25
0x4D00 0000 - 0x4D7F FFFF	-	PCI Master Window 26
0x4D80 0000 - 0x4DFF FFFF	-	PCI Master Window 27
0x4E00 0000 - 0x4E7F FFFF	-	PCI Master Window 28
0x4E80 0000 - 0x4EFF FFFF	-	PCI Master Window 29
0x4F00 0000 - 0x4F7F FFFF	-	PCI Master Window 30
0x4F80 0000 - 0x4FFF FFFF	-	PCI Master Window 31

6.17.3 PCI Electrical Data/Timing

Texas Instruments (TI) has performed the simulation and system characterization to be sure that the PCI peripheral meets all ac timing specifications as required by the *PCI Local Bus Specification* (version 2.3). The ac timing specifications are not reproduced here. For more information on the ac timing specifications, see Section 4.2.3, Timing Specification (33 MHz timing), and Section 7.6.4, Timing Specification (66 MHz timing), of the *PCI Local Bus Specification* (version 2.3). Note that the PCI peripheral only supports 3.3-V signaling.

6.18 Multichannel Audio Serial Port (McASP)

The McASP functions as a general-purpose audio serial port optimized for the needs of multichannel audio applications. The McASP is useful for time-division multiplexed (TDM) stream, Inter-Integrated Sound (I2S) protocols, and intercomponent digital audio interface transmission (DIT).

6.18.1 McASP Device-Specific Information

The device includes one multichannel audio serial port (McASP) interface peripheral. The McASP is a serial port optimized for the needs of multichannel audio applications.

The McASP consists of a transmit and receive section. These sections can operate completely independently with different data formats, separate master clocks, bit clocks, and frame syncs or alternatively, the transmit and receive sections may be synchronized. The McASP module also includes a pool of 16 shift registers that may be configured to operate as either transmit data or receive data.

The transmit section of the McASP can transmit data in either a time-division-multiplexed (TDM) synchronous serial format or in a digital audio interface (DIT) format where the bit stream is encoded for S/PDIF, AES-3, IEC-60958, CP-430 transmission. The receive section of the McASP supports the TDM synchronous serial format.

The McASP can support one transmit data format (either a TDM format or DIT format) and one receive format at a time. All transmit shift registers use the same format and all receive shift registers use the same format. However, the transmit and receive formats need not be the same.

Both the transmit and receive sections of the McASP also support burst mode which is useful for non-audio data (for example, passing control information between two DSPs).

The McASP peripheral has additional capability for flexible clock generation, and error detection/handling, as well as error management.

For more detailed information on and the functionality of the McASP peripheral, see the *TMS320DM647/DM648 Multichannel Audio Serial Port (McASP) User's Guide* (literature number [SPRUJEL1](#)).

6.18.1.1 McASP Block Diagram

[Figure 6-48](#) illustrates the major blocks along with external signals of the McASP peripheral; and shows the 10 serial data [AXR] pins.

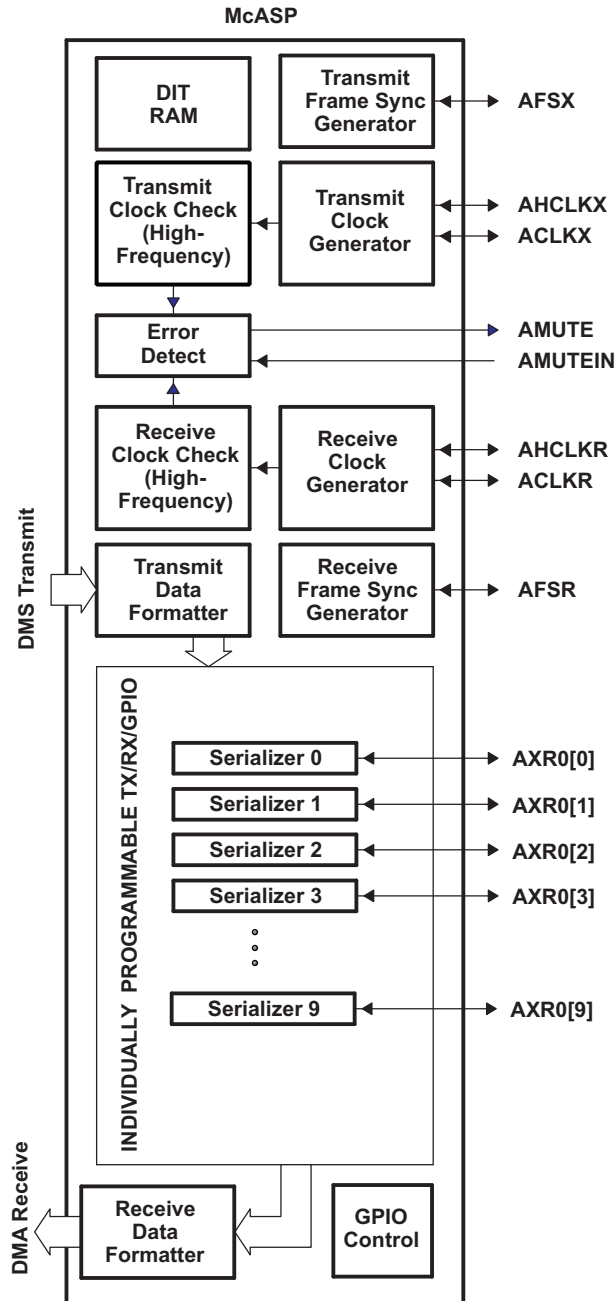

Figure 6-48. McASP Configuration

6.18.1.2 McASP Peripheral Register Description(s)

Table 6-73. McASP Control Registers

HEX ADDRESS RANGE	ACRONYM	REGISTER NAME
0x0204 0000	PID	Peripheral Identification register [Register value: 0x0010 0101]
0x0204 0004	PWRDEMU	Power down and emulation management register
0x0204 0008	-	Reserved
0x0204 000C	-	Reserved
0x0204 0010	PFUNC	Pin function register
0x0204 0014	PDIR	Pin direction register
0x0204 0018	PDOUT	Pin data out register
0x0204 001C	PDIN/PDSET	Pin data in/data set register Read returns: PDIN Writes affect: PDSET
0x0204 0020	PDCLR	Pin data clear register
0x0204 0024 - 0x0204 0040	-	Reserved
0x0204 0044	GBLCTL	Global control register
0x0204 0048	AMUTE	Mute control register
0x0204 004C	DLBCTL	Digital Loop-back control register
0x0204 0050	DITCTL	DIT mode control register
0x0204 0054 - 0x0204 005C	-	Reserved
0x0204 0060	RGBLCTL	Alias of GBLCTL containing only Receiver Reset bits, allows transmit to be reset independently from receive.
0x0204 0064	RMASK	Receiver format UNIT bit mask register
0x0204 0068	RFMT	Receive bit stream format register
0x0204 006C	AFSRCTL	Receive frame sync control register
0x0204 0070	ACLKRCTL	Receive clock control register
0x0204 0074	AHCLKRCTL	High-frequency receive clock control register
0x0204 0078	RTDM	Receive TDM slot 0-31 register
0x0204 007C	RINTCTL	Receiver interrupt control register
0x0204 0080	RSTAT	Status register - Receiver
0x0204 0084	RSLOT	Current receive TDM slot register
0x0204 0088	RCLKCHK	Receiver clock check control register
0x0204 008C - 0x0204 009C	-	Reserved
0x0204 00A0	XGBLCTL	Alias of GBLCTL containing only Transmitter Reset bits, allows transmit to be reset independently from receive.
0x0204 00A4	XMASK	Transmit format UNIT bit mask register
0x0204 00A8	XFMT	Transmit bit stream format register
0x0204 00AC	AFSXCTL	Transmit frame sync control register
0x0204 00B0	ACLKXCTL	Transmit clock control register
0x0204 00B4	AHCLKXCTL	High-frequency Transmit clock control register
0x0204 00B8	XTDM	Transmit TDM slot 0-31 register
0x0204 00BC	XINTCTL	Transmit interrupt control register
0x0204 00C0	XSTAT	Status register - Transmitter
0x0204 00C4	XSLOT	Current transmit TDM slot
0x0204 00C8	XCLKCHK	Transmit clock check control register

Table 6-73. McASP Control Registers (continued)

HEX ADDRESS RANGE	ACRONYM	REGISTER NAME
0x0204 00CC - 0x0204 00FC	-	Reserved
0x0204 0100	DITCSRA0	Left (even TDM slot) channel status register file
0x0204 0104	DITCSRA1	Left (even TDM slot) channel status register file
0x0204 0108	DITCSRA2	Left (even TDM slot) channel status register file
0x0204 010C	DITCSRA3	Left (even TDM slot) channel status register file
0x0204 0110	DITCSRA4	Left (even TDM slot) channel status register file
0x0204 0114	DITCSRA5	Left (even TDM slot) channel status register file
0x0204 0118	DITCSRB0	Right (odd TDM slot) channel status register file
0x0204 011C	DITCSRB1	Right (odd TDM slot) channel status register file
0x0204 0120	DITCSRB2	Right (odd TDM slot) channel status register file
0x0204 0124	DITCSRB3	Right (odd TDM slot) channel status register file
0x0204 0128	DITCSRB4	Right (odd TDM slot) channel status register file
0x0204 012C	DITCSRB5	Right (odd TDM slot) channel status register file
0x0204 0130	DITUDRA0	Left (even TDM slot) user data register file
0x0204 0134	DITUDRA1	Left (even TDM slot) user data register file
0x0204 0138	DITUDRA2	Left (even TDM slot) user data register file
0x0204 013C	DITUDRA3	Left (even TDM slot) user data register file
0x0204 0140	DITUDRA4	Left (even TDM slot) user data register file
0x0204 0144	DITUDRA5	Left (even TDM slot) user data register file
0x0204 0148	DITUDRB0	Right (odd TDM slot) user data register file
0x0204 014C	DITUDRB1	Right (odd TDM slot) user data register file
0x0204 0150	DITUDRB2	Right (odd TDM slot) user data register file
0x0204 0154	DITUDRB3	Right (odd TDM slot) user data register file
0x0204 0158	DITUDRB4	Right (odd TDM slot) user data register file
0x0204 015C	DITUDRB5	Right (odd TDM slot) user data register file
0x0204 0160 - 0x0204 017C	-	Reserved
0x0204 0180	SRCTL0	Serializer 0 control register
0x0204 0184	SRCTL1	Serializer 1 control register
0x0204 0188	SRCTL2	Serializer 2 control register
0x0204 018C	SRCTL3	Serializer 3 control register
0x0204 0190	SRCTL4	Serializer 4 control register
0x0204 0194	SRCTL5	Serializer 5 control register
0x0204 0198	SRCTL6	Serializer 6 control register
0x0204 019C	SRCTL7	Serializer 7 control register
0x0204 01A0	SRCTL8	Serializer 8 control register
0x0204 01A4	SRCTL9	Serializer 9 control register
0x0204 01A8 - 0x0204 01FC	-	Reserved
0x0204 0200	XBUF0	Transmit Buffer for Serializer 0
0x0204 0204	XBUF1	Transmit Buffer for Serializer 1
0x0204 0208	XBUF2	Transmit Buffer for Serializer 2
0x0204 020C	XBUF3	Transmit Buffer for Serializer 3
0x0204 0210	XBUF4	Transmit Buffer for Serializer 4
0x0204 0214	XBUF5	Transmit Buffer for Serializer 5
0x0204 0218	XBUF6	Transmit Buffer for Serializer 6
0x0204 021C	XBUF7	Transmit Buffer for Serializer 7

Table 6-73. McASP Control Registers (continued)

HEX ADDRESS RANGE	ACRONYM	REGISTER NAME
0x0204 021A	XBUF8	Transmit Buffer for Serializer 8
0x0204 0220	XBUF9	Transmit Buffer for Serializer 9
0x0204 0224-0x0204 027C	-	Reserved
0x0204 0280	RBUF0	Receive Buffer for Serializer 0
0x0204 0284	RBUF1	Receive Buffer for Serializer 1
0x0204 0288	RBUF2	Receive Buffer for Serializer 2
0x0204 028C	RBUF3	Receive Buffer for Serializer 3
0x0204 0290	RBUF4	Receive Buffer for Serializer 4
0x0204 0294	RBUF5	Receive Buffer for Serializer 5
0x0204 0298	RBUF6	Receive Buffer for Serializer 6
0x0204 029C	RBUF7	Receive Buffer for Serializer 7
0x0204 02A0	RBUF8	Receive Buffer for Serializer 8
0x0204 02A4	RBUF9	Receive Buffer for Serializer 9
0x0204 02A8-0x0204 3FFF	-	Reserved

Table 6-74. McASP Data Registers

HEX ADDRESS RANGE	ACRONYM	REGISTER NAME	COMMENTS
0204 4000 - 0204 43FF	RBUF/XBUF	McASP receive buffers or McASP transmit buffers via the Peripheral Data Bus.	(Used when RSEL or XSEL bits = 0 [these bits are located in the RFMT or XFMT registers, respectively].)

6.18.1.3 McASP Electrical Data/Timing

6.18.1.3.1 Multichannel Audio Serial Port (McASP) Timing

Table 6-75. Timing Requirements for McASP (see Figure 6-49 and Figure 6-50)⁽¹⁾

NO.			720, 800, 900, 1100		UNIT
			MIN	MAX	
1	$t_{c(AHCKRX)}$	Cycle time, AHCLKR/X	20		ns
2	$t_{w(AHCKRX)}$	Pulse duration, AHCLKR/X high or low	10		ns
3	$t_{c(CKRX)}$	Cycle time, ACLKR/X	ACLKR/X ext	33	ns
4	$t_{w(CKRX)}$	Pulse duration, ACLKR/X high or low	ACLKR/X ext	16.5	ns
5	$t_{su(FRX-CKRX)}$	Setup time, AFSR/X input valid before ACLKR/X latches data	ACLKR/X int	5	ns
			ACLKR/X ext	5	ns
6	$t_{h(CKRX-FRX)}$	Hold time, AFSR/X input valid after ACLKR/X latches data	ACLKR/X int	5	ns
			ACLKR/X ext	12.08	ns
7	$t_{su(AXR-CKRX)}$	Setup time, AXR input valid before ACLKR/X latches data	ACLKR/X int	5	ns
			ACLKR/X ext	5	ns
8	$t_{h(CKRX-AXR)}$	Hold time, AXR input valid after ACLKR/X latches data	ACLKR/X int	5	ns
			ACLKR/X ext	7.35	ns

(1) ACLKX internal: ACLKXCTL.CLKXM=1, PDIR.ACLKX = 1
 ACLKX external input: ACLKXCTL.CLKXM=0, PDIR.ACLKX=0
 ACLKX external output: ACLKXCTL.CLKXM=0, PDIR.ACLKX=1
 ACLKR internal: ACLKRCTL.CLKRM=1, PDIR.ACLKR = 1
 ACLKR external input: ACLKRCTL.CLKRM=0, PDIR.ACLKR=0
 ACLKR external output: ACLKRCTL.CLKRM=0, PDIR.ACLKR=1

Table 6-76. Switching Characteristics Over Recommended Operating Conditions for McASP
(see [Figure 6-49](#) and [Figure 6-50](#))⁽¹⁾

NO.	PARAMETER		720, 800, 900, 1100		UNIT
			MIN	MAX	
9	$t_{c(AHCKRX)}$	Cycle time, AHCLKR/X	20		ns
10	$t_{w(AHCKRX)}$	Pulse duration, AHCLKR/X high or low	10		ns
11	$t_{c(CKRX)}$	Cycle time, ACLKR/X	ACLKR/X int	33	ns
12	$t_{w(CKRX)}$	Pulse duration, ACLKR/X high or low	ACLKR/X int	16.5	ns
13	$t_{d(CKRX-FRX)}$	Delay time, ACLKR/X transmit edge to AFSX/R output valid	ACLKR/X int	5	ns
			ACLKR/X ext	14.28	ns
14	$t_{d(CKX-AXRV)}$	Delay time, ACLKX transmit edge to AXR output valid	ACLKX int	10	ns
			ACLKX ext	12.5	ns
15	$t_{dis(CKRX-AXRHZ)}$	Disable time, AXR high impedance following last data bit from ACLKR/X transmit edge	ACLKR/X int	10	ns
			ACLKR/X ext	12.5	ns

- (1) ACLKX internal: ACLKXCTL.CLKXM=1, PDIR.ACLKX = 1
ACLKX external input: ACLKXCTL.CLKXM=0, PDIR.ACLKX=0
ACLKX external output: ACLKXCTL.CLKXM=0, PDIR.ACLKX=1
ACLKR internal: ACLKRCTL.CLKRM=1, PDIR.ACLKR = 1
ACLKR external input: ACLKRCTL.CLKRM=0, PDIR.ACLKR=0
ACLKR external output: ACLKRCTL.CLKRM=0, PDIR.ACLKR=1

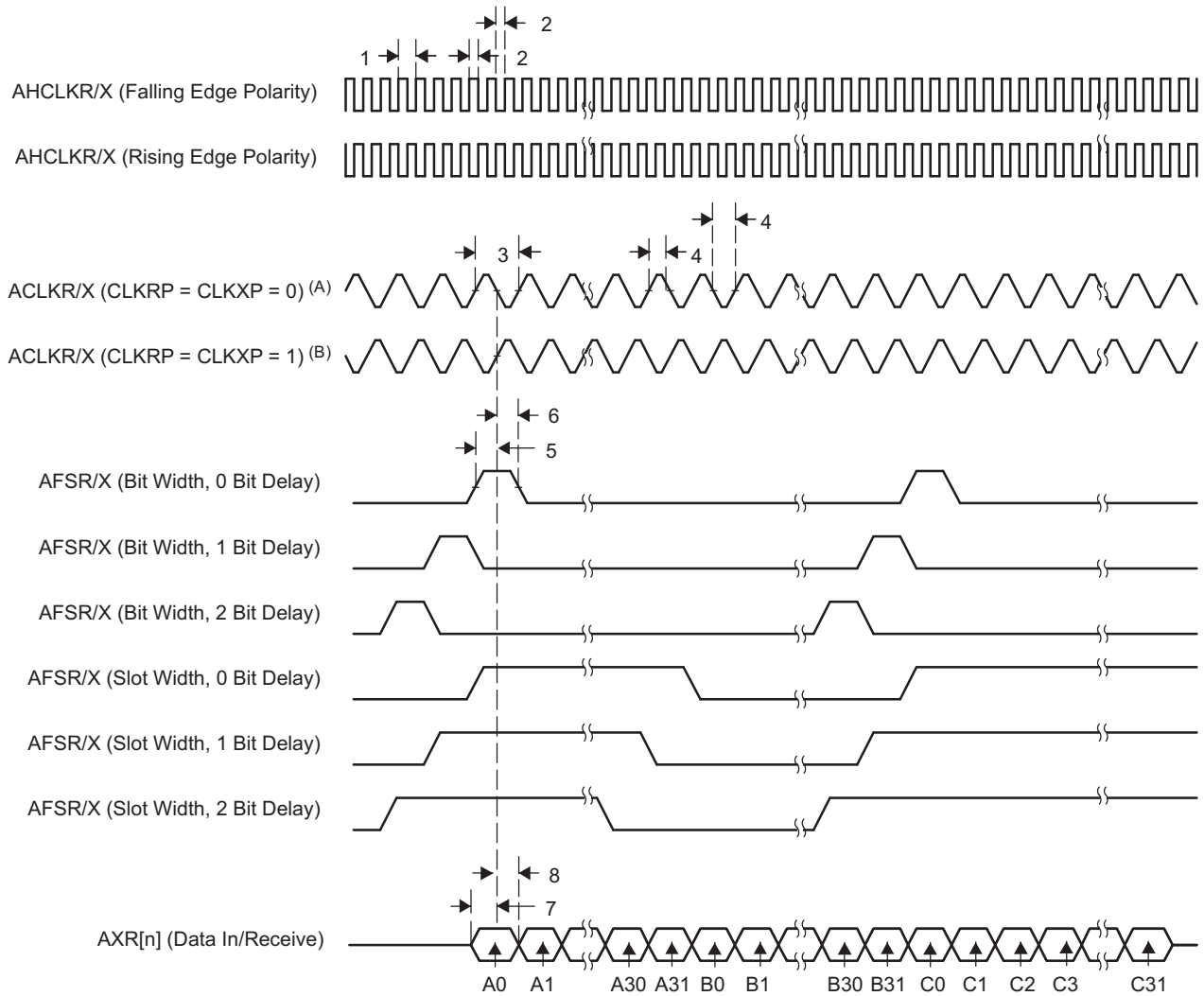

- A. For CLKRP = CLKXP = 0, the McASP transmitter is configured for rising edge (to shift data out) and the McASP receiver is configured for falling edge (to shift data in).
- B. For CLKRP = CLKXP = 1, the McASP transmitter is configured for falling edge (to shift data out) and the McASP receiver is configured for rising edge (to shift data in).

Figure 6-49. McASP Input Timing

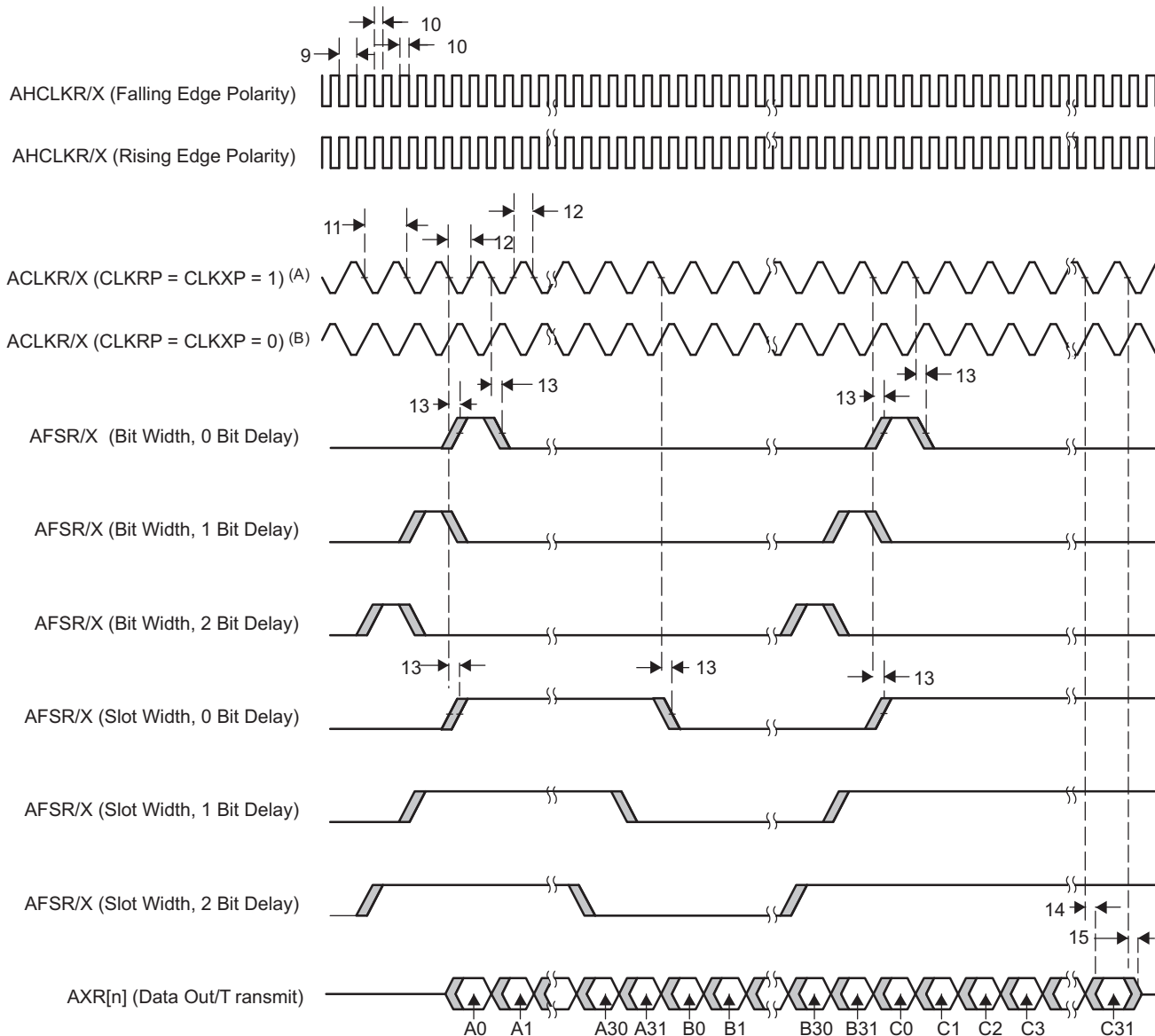

- A. For CLKRP = CLKXP = 1, the McASP transmitter is configured for falling edge (to shift data out) and the McASP receiver is configured for rising edge (to shift data in).
- B. For CLKRP = CLKXP = 0, the McASP transmitter is configured for rising edge (to shift data out) and the McASP receiver is configured for falling edge (to shift data in).

Figure 6-50. McASP Output Timing

6.19 3-Port Ethernet Switch Subsystem (3PSW)

The Ethernet module controls the flow of packet data between the device and two external Ethernet PHYs (DM648 only) or one external Ethernet PHY (DM647 only), with hardware flow control and quality-of-service (QoS) support. See [Figure 6-51](#) for a block diagram of the Ethernet module. The Ethernet Subsystem contains a 3-port gigabit switch, where one port is internally connected to the C64x+ DSP (via the switched central resource) and the other two ports are brought out externally. Each of the external Ethernet ports support the modes shown in [Table 6-77](#).

The Ethernet module controls the flow of packet data between the device and two external Ethernet PHYs , with hardware flow control and quality-of-service (QoS) support. See [Figure 6-51](#) for a block diagram of the Ethernet module. The Ethernet Subsystem contains a 3-port gigabit switch, where one port is internally connected to the C64x+ DSP (via the switched central resource) and the other two ports are brought out externally. Each of the external Ethernet ports support the modes shown in [Table 6-77](#).

Table 6-77. Ethernet Operating Modes

DESCRIPTION	DATA RATE	OPERATING MODE
10Base-T	10 Mbits/second (Mbps)	half- or full-duplex
100Base-T	100 Mbits/second (Mbps)	half- or full-duplex
1000Base-T	1000 Mbits/second (Mbps)	full-duplex

The Ethernet Subsystem provides these functions:

- Ethernet communication/routing by way of two dedicated 10/100/1000 ports with SGMII interfaces
 - Wire-rate switching (802.1d), non-blocking switch fabric
 - Four priority levels of QoS TX support (802.1p) in hardware
 - Programmable interrupt pacing on RX/TX plus interrupt threshold on RX
 - Supports forwarding frame sizes of 64-2020 bytes
- Address Lookup
 - 1024 total address lookup engine (ALE) entries of VLANs and/or MAC addresses
 - L2 address lock and L2 filtering support
 - Multicast/broadcast filtering and forwarding state control
 - Receive-based or destination-based multicast and broadcast rate limits
 - MAC address blocking
 - Source port locking
 - OUI (Vendor ID) host accept/deny feature
 - Host controlled time-based aging
 - MAC authentication (802.1x)
 - Remapping of priority level of VLAN or ports
 - Multiple spanning tree support (spanning tree per VLAN)

- VLAN support
 - 802.1Q compliant
 - Auto add port VLAN for untagged frames on ingress
 - Auto VLAN removal on egress and auto pad to minimum frame size
 - Flow control (IEEE 802.3x)
 - Programmable priority escalation to specify delivery of lower priority level packets in the event of over-subscribed TX high priority traffic
 - Host pass CRC mode (enables CRC protection through host)
 - Write-protect option for Ethernet module registers (3PGSW, CPPI RAM, MDIO, SGMII0, SGMII1, control)
 - Ethernet statistics:
 - EtherStats and 802.3 Stats RMON statistics gathering (shared)
 - Programmable statistics interrupt mask when a statistic is above one half its 32-bit value
 - MDIO module for PHY management
 - SGMII gigabit current mode logic (CML) differential SERIALizer/DESerializer (SerDes) I/O receiver/transmitters
 - Adaptive active equalization for superior data dependent jitter tolerance in the presence of a lossy channel
 - Loss of signal detector with programmable threshold levels in receive channels
 - Integrated receiver and transmitter termination
 - IEEE 802.3 gigabit Ethernet conformant

6.19.1 Ethernet Subsystem Functions

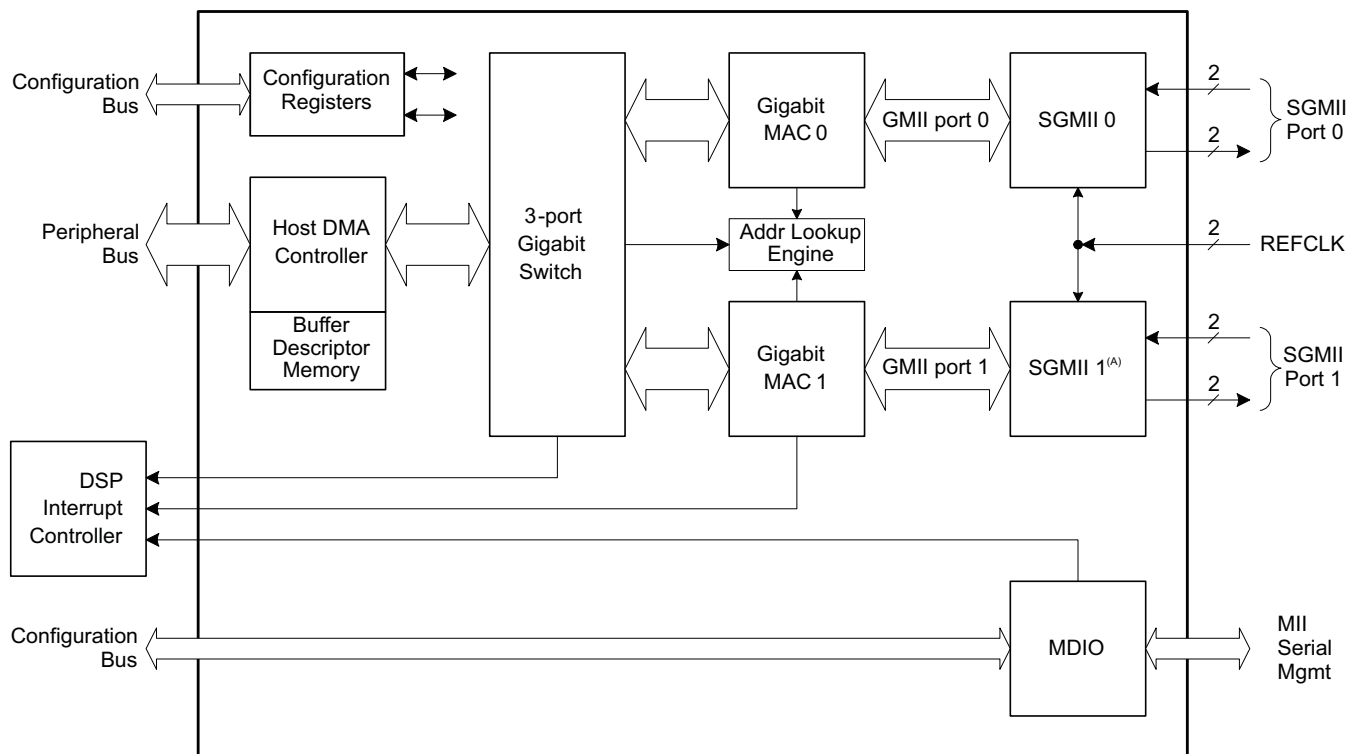

A. SGMII port 1 is not available on DM647.

Figure 6-51. Ethernet Subsystem Block Diagram

The Ethernet Subsystem conforms to the IEEE 802.3-2002 standard. Deviating from this standard, the GMAC module does not use the transmit coding error signal MTXER. Instead of driving the error pin when an underflow condition occurs on a transmitted frame, the GMAC generates an incorrect checksum by inverting the frame CRC, so that the transmitted frame will be detected as an error by the network.

In networking systems, packet transmission and reception are critical tasks. The communications port programming interface (CPPI) protocol maximizes the efficiency of interaction between the host software and communications modules. The CPPI block contains 2048 words of 32-bit buffer descriptor memory that holds up to 512 buffer descriptors.

After reset, initialization, configuration, and auto-negotiation, the host C64x+ DSP may initiate Ethernet transmit and receive operations.

- Transmit operations are initiated by C64x+ DSP writes to the appropriate transmit channel head descriptor pointer contained in the CPDMA block. The CPDMA TX controller then fetches the first packet in the packet chain from memory in accordance with the CPPI protocol for the GMAC to process before sending to the SGMII.
- Receive operations are initiated by C64x+ DSP writes to the appropriate receive channel head descriptor pointer. The CPDMA RX controller then writes packets to memory in accordance with the CPPI protocol.

DSP writes may be write-protected to the Ethernet Subsystem configuration registers from addresses 0x02D0 0000 - 0x02D0 4FFF (3PGSW, MDIO, SGMII0, SGMII1, control), and the CPPI RAM. The Ethernet Subsystem setting in the PSC is also write-protected. A specific 32-bit lock code (0x4C6F436B) and a 32-bit unlock code (0x6F50654E) written to ESS_LOCK register will activate or clear this option, respectively. See [Section 3.2.5](#) and [Section 3.2.7](#)

The 3-port gigabit switch block contains the following functions:

- 3-port gigabit switch: performs packet forwarding and routing functions, one port is internally connected to the C64x+ DSP and two ports are brought out externally
- CPDMA: performs high-speed DMA transfers with RX and TX CPPI buffers in local memory, including channel setup and channel teardown
- GMAC (Gigabit Ethernet MAC):
 - Uses Rx packet FIFO, and a TX packet FIFO to improve data transfer efficiency
 - Handles processing of Ethernet packet data, frames, and headers
 - Includes flow control
 - Provides statistics collection and reporting
- The address lookup engine (ALE) processes all received packets to determine where (that is, which packet location) to forward the packet. The ALE uses the incoming packet received port number, destination address, source address, length/type, and VLAN information to determine how the packet should be forwarded. The ALE outputs the port mask to the switch fabric that indicates to which port(s) the packet should be forwarded.

6.19.2 Interrupt Controller and Pacing Interrupts

The interrupt control block selects the interrupts from the 3-port gigabit switch and MDIO modules for output to the C64x+ DSP. The miscellaneous interrupt is an immediate (non-paced) interrupt selected from the miscellaneous interrupts (host error level, statistics level, MDIO User [2], MDIO link [2]).

The eight RX interrupts and eight TX interrupts can be paced. The 8 RX threshold interrupts and the miscellaneous interrupts are not paced. The interrupt pacing feature limits the number of interrupts that occur during a given period of time. For heavily loaded systems in which interrupts can occur at a very high rate, the performance benefit is significant due to minimizing the overhead associated with servicing each interrupt. Interrupt pacing increases the C64x+ DSP cache hit ratio by minimizing the number of times that large interrupt service routines are moved to and from the DSP instruction cache.

MDIO

The MDIO module manages the PHY configuration and monitors status. For a list of supported registers and register fields, see [Table 6-79](#). In 10/100 mode, the GMII_MTXD(7:0) data bus uses only the lower nibble.

SGMII

The SGMII/SerDes module contains:

- Gigabit differential current mode logic (CML) receiver/transmitters
- An integrated RX/TX PLL to provide the required high-quality/high-speed internal clocks
- Phase-interpolator-based clock/data recovery
- A bandgap reference for transmitter swing settings
- Parallel-to-serial converter
- Serial-to-parallel converter
- Integrated receiver and transmitter termination
- Configuration logic
- 802.3 auto-negotiation functionality (as defined in Clause 37 of the IEEE Specification 802.3)

The SGMII receive interface converts the encoded receive signals from the differential receive input terminals (SGMII0RXN: SGMII0RXP, SGMII1RXN: SGMII1RXP) into the required GMAC GMII signals. The SGMII transmit interface converts the GMAC GMII data into the required encoded differential transmit output terminals (SGMII0TXN: SGMII0TXP, SGMII1TXN: SGMII1TXP). The GMAC does not source the transmit error signal. Any transmit frame from the GMAC with an error (ie., underrun) will be indicated as an error by an error CRC.

NOTE

SGMII1 is pinned out only in the DM648 device. The DM647 device has only one SGMII port (SGMII0).

6.19.3 Peripheral Register Description(s)

[Table 6-78](#) through [Table 6-81](#) list the registers.

Table 6-78. Ethernet Switch Registers

HEX ADDRESS RANGE	REGISTER ACRONYM	DESCRIPTION
0x02D0 3000	CPSW_ID_VER	CPSW Identification and Version Register
0x02D0 3004	CPSW_CONTROL	CPSW Switch Control Register
0x02D0 3008	CPSW_SOFT_RESET	CPSW Soft Reset Register
0x02D0 300C	CPSW_STAT_PORT_EN	CPSW Statistics Port Enable Register
0x02D0 3010	CPSW_PTYPE	CPSW Transmit Priority Type Register
0x02D0 3014	P0_MAX_BLKs	CPSW Port 0 Maximum FIFO blocks Register
0x02D0 3018	P0_BLK_CNT	CPSW Port 0 FIFO Block Usage Count Register (read only)
0x02D0 301C	P0_FLOW_THRESH	CPSW Port 0 Flow Control Threshold Register
0x02D0 3020	P0_PORT_VLAN	CPSW Port 0 VLAN Register
0x02D0 3024	P0_TX_PRI_MAP	CPSW Port 0 Tx Header Pri to Switch Pri Mapping Register
0x02D0 3028	GMAC0_GAP_THRESH	CPSW GMAC0 Short Gap Threshold Register
0x02D0 302C	GMAC0_SA_LO	CPSW GMAC0 Source Address Low Register
0x02D0 3030	GMAC0_SA_HI	CPSW GMAC0 Source Address High Register
0x02D0 3034	P1_MAX_BLKs	CPSW Port 1 Maximum FIFO blocks Register
0x02D0 3038	P1_BLK_CNT	CPSW Port 1 FIFO Block Usage Count Register (read only)
0x02D0 303C	P1_FLOW_THRESH	CPSW Port 1 Flow Control Threshold Register
0x02D0 3040	P1_PORT_VLAN	CPSW Port 1 VLAN Register

Table 6-78. Ethernet Switch Registers (continued)

HEX ADDRESS RANGE	REGISTER ACRONYM	DESCRIPTION
0x02D0 3044	P1_TX_PRI_MAP	CPSW Port 1 Tx Header Priority to Switch Pri Mapping Register
0x02D0 3048	GMAC1_GAP_THRESH	CPSW GMAC1 Short Gap Threshold Register
0x02D0 304C	GMAC1_SA_LO	CPSW GMAC1 Source Address Low Register
0x02D0 3050	GMAC1_SA_HI	CPSW GMAC1 Source Address High Register
0x02D0 3054	P2_MAX_BLKs	CPSW Port 2 Maximum FIFO blocks Register
0x02D0 3058	P2_BLK_CNT	CPSW Port 2 FIFO Block Usage Count Register (read only)
0x02D0 305C	P2_FLOW_THRESH	CPSW Port 2 Flow Control Threshold Register
0x02D0 3060	P2_PORT_VLAN	CPSW Port 2 VLAN Register
0x02D0 3064	P2_TX_PRI_MAP	CPSW Port 2 Tx (CPDMA Rx) Header Priority to Switch Pri Mapping Register
0x02D0 3068	CPDMA_TX_PRI_MAP	CPSW CPDMA Tx (Port 2 Rx) Pkt Priority to Header Priority Mapping Register
0x02D0 306C	CPDMA_RX_CH_MAP	CPSW CPDMA Rx (Port 2 Tx) Switch Priority to DMA channel Mapping Register
0x02D0 3070 - 0x02D0 307C	reserved	
0x02D0 3080	GMAC0_IDVER	GMAC0 Identification and Version Register
0x02D0 3084	GMAC0_MACCONTROL	GMAC0 Mac Control Register
0x02D0 3088	GMAC0_MACSTATUS	GMAC0 Mac Status Register
0x02D0 308C	GMAC0_SOFT_RESET	GMAC0 Soft Reset Register
0x02D0 3090	GMAC0_RX_MAXLEN	GMAC0 RX Maximum Length Register
0x02D0 3094	GMAC0_BOFFTEST	GMAC0 Backoff Test Register
0x02D0 3098	reserved	
0x02D0 309C	reserved	
0x02D0 30A0	GMAC0_EMCONTROL	GMAC0 Emulation Control Register
0x02D0 30A4	GMAC0_RX_PRI_MAP	GMAC0 Rx Pkt Priority to Header Priority Mapping Register
0x02D0 30A8 - 0x02D0 30BC	reserved	
0x02D0 30C0	GMAC1_IDVER	GMAC1 Identification and Version Register
0x02D0 30C4	GMAC1_MACCONTROL	GMAC1 Mac Control Register
0x02D0 30C8	GMAC1_MACSTATUS	GMAC1 Mac Status Register
0x02D0 30CC	GMAC1_SOFT_RESET	GMAC1 Soft Reset Register
0x02D0 30D0	GMAC1_RX_MAXLEN	GMAC1 RX Maximum Length Register
0x02D0 30D4	GMAC1_BOFFTEST	GMAC1 Backoff Test Register
0x02D0 30D8	reserved	
0x02D0 30DC	reserved	
0x02D0 30E0	GMAC1_EMCONTROL	GMAC1 Emulation Control Register
0x02D0 30E4	GMAC1_RX_PRI_MAP	GMAC1 Rx Pkt Priority to Header Priority Mapping Register
0x02D0 30E8 - 0x02D0 30FC	reserved	
0x02D0 3100	TX_IDVER	CPDMA Tx Identification and Version Register
0x02D0 3104	TX_CONTROL	CPDMA Tx Control Register
0x02D0 3108	TX_TEARDOWN	CPDMA Tx Teardown Register
0x02D0 310C	reserved	
0x02D0 3110	RX_IDVER	CPDMA Rx Identification and Version Register
0x02D0 3114	RX_CONTROL	CPDMA Rx Control Register
0x02D0 3118	RX_TEARDOWN	CPDMA Rx Teardown Register
0x02D0 311C	SOFT_RESET	CPDMA Soft Reset Register
0x02D0 3120	DMACONTROL	CPDMA Control Register
0x02D0 3124	DMASTATUS	CPDMA Status Register

Table 6-78. Ethernet Switch Registers (continued)

HEX ADDRESS RANGE	REGISTER ACRONYM	DESCRIPTION
0x02D0 3128	RX_BUFFER_OFFSET	CPDMA Rx Buffer Offset Register
0x02D0 312C	EMCONTROL	CPDMA Emulation Control Register
0x02D0 3130 - 0x02D0 317C	reserved	
0x02D0 3180	TX_INTSTAT_RAW	CPDMA Tx interrupt Status Register (raw value)
0x02D0 3184	TX_INTSTAT_MASKED	CPDMA Tx Interrupt Status Register (masked value)
0x02D0 3188	TX_INTMASK_SET	CPDMA Tx Interrupt Mask Set Register
0x02D0 318C	TX_INTMASK_CLEAR	CPDMA Tx Interrupt Mask Clear Register
0x02D0 3190	CPDMA_IN_VECTOR	CPDMA Input Vector Register (read only)
0x02D0 3194	CPDMA_EOI_VECTOR	CPDMA End Of Interrupt Vector Register
0x02D0 3198 - 0x02D0 319C	reserved	
0x02D0 31A0	RX_INTSTAT_RAW	CPDMA Rx Interrupt Status Register (raw value)
0x02D0 31A4	RX_INTSTAT_MASKED	CPDMA Rx Interrupt Status Register (masked value)
0x02D0 31A8	RX_INTMASK_SET	CPDMA Rx Interrupt Mask Set Register
0x02D0 31AC	RX_INTMASK_CLEAR	CPDMA Rx Interrupt Mask Clear Register
0x02D0 31B0	DMA_INTSTAT_RAW	CPDMA DMA Interrupt Status Register (raw value)
0x02D0 31B4	DMA_INTSTAT_MASKED	CPDMA DMA Interrupt Status Register (masked value)
0x02D0 31B8	DMA_INTMASK_SET	CPDMA DMA Interrupt Mask Set Register
0x02D0 31BC	DMA_INTMASK_CLEAR	CPDMA DMA Interrupt Mask Clear Register
0x02D0 31C0	RX0_PENDTHRESH	CPDMA Rx Threshold Pending Register Channel 0
0x02D0 31C4	RX1_PENDTHRESH	CPDMA Rx Threshold Pending Register Channel 1
0x02D0 31C8	RX2_PENDTHRESH	CPDMA Rx Threshold Pending Register Channel 2
0x02D0 31CC	RX3_PENDTHRESH	CPDMA Rx Threshold Pending Register Channel 3
0x02D0 31D0	RX4_PENDTHRESH	CPDMA Rx Threshold Pending Register Channel 4
0x02D0 31D4	RX5_PENDTHRESH	CPDMA Rx Threshold Pending Register Channel 5
0x02D0 31D8	RX6_PENDTHRESH	CPDMA Rx Threshold Pending Register Channel 6
0x02D0 31DC	RX7_PENDTHRESH	CPDMA Rx Threshold Pending Register Channel 7
0x02D0 31E0	RX0_FREEBUFFER	CPDMA Rx Free Buffer Register Channel 0
0x02D0 31E4	RX1_FREEBUFFER	CPDMA Rx Free Buffer Register Channel 1
0x02D0 31E8	RX2_FREEBUFFER	CPDMA Rx Free Buffer Register Channel 2
0x02D0 31EC	RX3_FREEBUFFER	CPDMA Rx Free Buffer Register Channel 3
0x02D0 31F0	RX4_FREEBUFFER	CPDMA Rx Free Buffer Register Channel 4
0x02D0 31F4	RX5_FREEBUFFER	CPDMA Rx Free Buffer Register Channel 5
0x02D0 31F8	RX6_FREEBUFFER	CPDMA Rx Free Buffer Register Channel 6
0x02D0 31FC	RX7_FREEBUFFER	CPDMA Rx Free Buffer Register Channel 7
0x02D0 3200	TX0_HDP	CPDMA Tx Channel 0 Head Desc Pointer
0x02D0 3204	TX1_HDP	CPDMA Tx Channel 1 Head Desc Pointer
0x02D0 3208	TX2_HDP	CPDMA Tx Channel 2 Head Desc Pointer
0x02D0 320C	TX3_HDP	CPDMA Tx Channel 3 Head Desc Pointer
0x02D0 3210	TX4_HDP	CPDMA Tx Channel 4 Head Desc Pointer
0x02D0 3214	TX5_HDP	CPDMA Tx Channel 5 Head Desc Pointer
0x02D0 3218	TX6_HDP	CPDMA Tx Channel 6 Head Desc Pointer
0x02D0 321C	TX7_HDP	CPDMA Tx Channel 7 Head Desc Pointer
0x02D0 3220	RX0_HDP	CPDMA Rx 0 Channel 0 Head Desc Pointer
0x02D0 3224	RX1_HDP	CPDMA Rx 1 Channel 1 Head Desc Pointer
0x02D0 3228	RX2_HDP	CPDMA Rx 2 Channel 2 Head Desc Pointer
0x02D0 322C	RX3_HDP	CPDMA Rx 3 Channel 3 Head Desc Pointer
0x02D0 3230	RX4_HDP	CPDMA Rx 4 Channel 4 Head Desc Pointer

Table 6-78. Ethernet Switch Registers (continued)

HEX ADDRESS RANGE	REGISTER ACRONYM	DESCRIPTION
0x02D0 3234	RX5_HDP	CPDMA Rx 5 Channel 5 Head Desc Pointer
0x02D0 3238	RX6_HDP	CPDMA Rx 6 Channel 6 Head Desc Pointer
0x02D0 323C	RX7_HDP	CPDMA Rx 7 Channel 7 Head Desc Pointer
0x02D0 3240	TX0_CP	CPDMA Tx Channel 0 Completion Pointer Register
0x02D0 3244	TX1_CP	CPDMA Tx Channel 1 Completion Pointer Register
0x02D0 3248	TX2_CP	CPDMA Tx Channel 2 Completion Pointer Register
0x02D0 324C	TX3_CP	CPDMA Tx Channel 3 Completion Pointer Register
0x02D0 3250	TX4_CP	CPDMA Tx Channel 4 Completion Pointer Register
0x02D0 3254	TX5_CP	CPDMA Tx Channel 5 Completion Pointer Register
0x02D0 3258	TX6_CP	CPDMA Tx Channel 6 Completion Pointer Register
0x02D0 325C	TX7_CP	CPDMA Tx Channel 7 Completion Pointer Register
0x02D0 3260	RX0_CP	CPDMA Rx Channel 0 Completion Pointer Register
0x02D0 3264	RX1_CP	CPDMA Rx Channel 1 Completion Pointer Register
0x02D0 3268	RX2_CP	CPDMA Rx Channel 2 Completion Pointer Register
0x02D0 326C	RX3_CP	CPDMA Rx Channel 3 Completion Pointer Register
0x02D0 3270	RX4_CP	CPDMA Rx Channel 4 Completion Pointer Register
0x02D0 3274	RX5_CP	CPDMA Rx Channel 5 Completion Pointer Register
0x02D0 3278	RX6_CP	CPDMA Rx Channel 6 Completion Pointer Register
0x02D0 327C	RX7_CP	CPDMA Rx Channel 7 Completion Pointer Register
0x02D0 3280 - 0x02D0 32BF	reserved	
0x02D0 32C0 - 0x02D0 32FC	reserved	
0x02D0 3300 - 0x02D0 337C	reserved	
0x02D0 3380 - 0x02D0 33FC	reserved	
0x02D0 3400	RXGOODFRAMES	CPSW_STATS Total number of good frames received
0x02D0 3404	RXBROADCASTFRAMES	CPSW_STATS Total number of good broadcast frames received
0x02D0 3408	RXMULTICASTFRAMES	CPSW_STATS Total number of good multicast frames received
0x02D0 340C	RXPAUSEFRAMES	CPSW_STATS PauseRxFrames
0x02D0 3410	RXCRCERRORS	CPSW_STATS Total number of CRC errors frames received
0x02D0 3414	RXALIGNCODEERRORS	CPSW_STATS Total number of alignment/code errors received
0x02D0 3418	RXOVERSIZEDFRAMES	CPSW_STATS Total number of oversized frames received
0x02D0 341C	RXJABBERFRAMES	CPSW_STATS Total number of jabber frames received
0x02D0 3420	RXUNDERSIZEDFRAMES	CPSW_STATS Total number of undersized frames received
0x02D0 3424	RXFRAGMENTS	CPSW_STATS RxFragments received
0x02D0 3428	reserved	
0x02D0 342C	reserved	
0x02D0 3430	RXOCTETS	CPSW_STATS Total number of received bytes in good frames
0x02D0 3434	TXGOODFRAMES	CPSW_STATS GoodTxFrames
0x02D0 3438	TXBROADCASTFRAMES	CPSW_STATS BroadcastTxFrames
0x02D0 343C	TXMULTICASTFRAMES	CPSW_STATS MulticastTxFrames
0x02D0 3440	TXPAUSEFRAMES	CPSW_STATS PauseTxFrames
0x02D0 3444	TXDEFERREDFRAMES	CPSW_STATS Deferred Frames
0x02D0 3448	TXCOLLISIONFRAMES	CPSW_STATS Collisions
0x02D0 344C	TXSINGLECOLLFRAMES	CPSW_STATS SingleCollisionTxFrames
0x02D0 3450	TXMULTCOLLFRAMES	CPSW_STATS MultipleCollisionTxFrames

Table 6-78. Ethernet Switch Registers (continued)

HEX ADDRESS RANGE	REGISTER ACRONYM	DESCRIPTION
0x02D0 3454	TXEXCESSIVECOLLISIONS	CPSW_STATS ExcessiveCollisions
0x02D0 3458	TXLATECOLLISIONS	CPSW_STATS LateCollisions
0x02D0 345C	TXUNDERRUN	CPSW_STATS Transmit Underrun Error
0x02D0 3460	TXCARRIERSENSEERRORS	CPSW_STATS CarrierSenseErrors
0x02D0 3464	TXOCTETS	CPSW_STATS TxOctets
0x02D0 3468	OCTETFRAMES64	CPSW_STATS 64octetFrames
0x02D0 346C	OCTETFRAMES65T127	CPSW_STATS 65-127octetFrames
0x02D0 3470	OCTETFRAMES128T255	CPSW_STATS 128-255octetFrames
0x02D0 3474	OCTETFRAMES256T511	CPSW_STATS 256-511octetFrames
0x02D0 3478	OCTETFRAMES512T1023	CPSW_STATS 512-1023octetFrames
0x02D0 347C	OCTETFRAMES1024TUP	CPSW_STATS 1023-1518octetFrames
0x02D0 3480	NETOCTETS	CPSW_STATS NetOctets
0x02D0 3484	RXSOFOVERRUNS	CPSW_STATS Receive FIFO or DMA Start of Frame Overruns
0x02D0 3488	RXMOFOVERRUNS	CPSW_STATS Receive FIFO or DMA Mid of Frame Overruns
0x02D0 348C	RXDMAOVERRUNS	CPSW_STATS Receive DMA Start of Frame and Middle of Frame Overruns
0x02D0 3490 - 0x02D0 34FC	reserved	
0x02D0 3500	ALE_IDVER	ALE Identification and Version Register
0x02D0 3504	reserved	
0x02D0 3508	ALE_CONTROL	ALE Control Register
0x02D0 350C	reserved	
0x02D0 3510	ALE_PRESCALE	ALE Prescale Register
0x02D0 3514	reserved	
0x02D0 3518	ALE_UNKNOWN_VLAN	ALE Unknown VLAN Register
0x02D0 351C	reserved	
0x02D0 3520	ALE_TBLCTL	ALE Table Control Register
0x02D0 3524 - 0x02D0 3530	reserved	
0x02D0 3534	ALE_TBLW2	ALE Table Word 2 Register
0x02D0 3538	ALE_TBLW1	ALE Table Word 1 Register
0x02D0 353C	ALE_TBLW0	ALE Table Word 0 Register
0x02D0 3540	ALE_PORTCTL0	ALE Port 0 Control Register
0x02D0 3544	ALE_PORTCTL1	ALE Port 1 Control Register
0x02D0 3548	ALE_PORTCTL2	ALE Port 2 Control Register
0x02D0 354C - 0x02D0 37FF	reserved	

Table 6-79. Ethernet Subsystem Registers

HEX ADDRESS RANGE	REGISTER ACRONYM	DESCRIPTION
0x02D0 2000	IDVER	Identification and Version Register
0x02D0 2004	SOFT_RESET	Soft Reset Register
0x02D0 2008	EM_CONTROL	Emulation Control Register
0x02D0 200C	INT_CONTROL	Interrupt Control Register
0x02D0 2010	RX_THRESH_EN	Receive Threshold Interrupt Enable Register
0x02D0 2014	RX_EN	Receive Interrupt Enable Register
0x02D0 2018	TX_EN	Transmit Interrupt Enable Register
0x02D0 201C	MISC_EN	Misc Interrupt Enable Register
0x02D0 2020	RX_THRESH_STAT	Receive Threshold Masked Interrupt Status Register

Table 6-79. Ethernet Subsystem Registers (continued)

HEX ADDRESS RANGE	REGISTER ACRONYM	DESCRIPTION
0x02D0 2024	RX_STAT	Receive Interrupt Masked Interrupt Status Register
0x02D0 2028	TX_STAT	Transmit Interrupt Masked Interrupt Status Register
0x02D0 202C	MISC_STAT	Misc Interrupt Masked Interrupt Status Register
0x02D0 2030	RX_IMAX	Receive Interrupts Per Millisecond
0x02D0 2034	TX_IMAX	Transmit Interrupts Per Millisecond

Table 6-80. SGMIIO Registers

HEX ADDRESS RANGE	REGISTER NAME	DESCRIPTION
0x02D0 4800	IDVER	Identification and Version Register
0x02D0 4804	SOFT_RESET	Soft Reset Register
0x02D0 4808 - 0x02D0 480C	Reserved	Reserved
0x02D0 4810	CONTROL	Control Register
0x02D0 4814	STATUS	Status Register (read only)
0x02D0 4818	MR_ADV_ABILITY	Advertised Ability Register
0x02D0 481C	MR_NP_TX	Transmit Next Page Register
0x02D0 4820	MR_LP_ADV_ABILITY	Link Partner Advertised Ability (read only)
0x02D0 4824	MR_NP_RX	Link Partner Receive Next Page Register (read only)
0x02D0 4828 - 0x02D0 482C	Reserved	Reserved
0x02D0 4830	Reserved	Reserved
0x02D0 4834	Reserved	Reserved
0x02D0 4838	Reserved	Reserved
0x02D0 483C	Reserved	Reserved
0x02D0 4840	DIAG_CLEAR	Diagnostics Clear Register
0x02D0 4844	DIAG_CONTROL	Diagnostics Control Register
0x02D0 4848	DIAG_STATUS	Diagnostics Status Register (read only)
0x02D0 484C - 0x02D0 487F	Reserved	Reserved

Table 6-81. SGMI1 Registers

HEX ADDRESS RANGE	REGISTER NAME	DESCRIPTION
0x02D0 4C00	IDVER	Identification and Version Register
0x02D0 4C04	SOFT_RESET	Soft Reset Register
0x02D0 4C08 - 0x02D0 4C0C	Reserved	Reserved
0x02D0 4C10	CONTROL	Control Register
0x02D0 4C14	STATUS	Status Register (read only)
0x02D0 4C18	MR_ADV_ABILITY	Advertised Ability Register
0x02D0 4C1C	MR_NP_TX	Transmit Next Page Register
0x02D0 4C20	MR_LP_ADV_ABILITY	Link Partner Advertised Ability (read only)
0x02D0 4C24	MR_NP_RX	Link Partner Receive Next Page Register (read only)
0x02D0 4C28 - 0x02D0 4C2C	Reserved	Reserved
0x02D0 4C30	Reserved	Reserved
0x02D0 4C34	Reserved	Reserved
0x02D0 4C38	Reserved	Reserved
0x02D0 4C3C	Reserved	Reserved
0x02D0 4C40	DIAG_CLEAR	Diagnostics Clear Register
0x02D0 4C44	DIAG_CONTROL	Diagnostics Control Register
0x02D0 4C48	DIAG_STATUS	Diagnostics Status Register (read only)
0x02D0 4C4C - 0x02D0 4C7F	Reserved	Reserved

6.19.4 Ethernet Subsystem Timing

Table 6-82. Ethernet Subsystem Timing Requirements

PARAMETER ⁽¹⁾	MIN	NOM	MAX	UNITS
t ₀₁ REFCLKP/N period, mode				
x 10 mode		8		ns
x 20 mode		16		ns
x 25 mode		20		ns
t ₀₂ REFCLKP/N duty cycle	40		60	%
t ₀₃ REFCLKP/N rise/fall		700		ps
t ₀₄ PLL Clock Period, x n Mode		t ₀₁ / n		ns
t ₀₅ PLL power up			1 + 200 * C	µs

(1) C = REFCLKP/N period in µs.

REFCLKP/N Jitter and PLL Loop Bandwidth

Jitter on the reference clock will degrade both the transmit eye and receiver jitter tolerance thereby impairing system performance. A good quality, low jitter reference clock is necessary to achieve compliance with most if not all physical layer standards (see [Table 6-83](#)).

Table 6-83. REFCLKP/N Jitter Requirements for Standards Compliance

Standard	Line Rate (Gbps)	Total REFCLKP/N Jitter (within PLL bandwidth)
Gigabit Ethernet	1.25	50 ps pk-pk

6.20 Management Data Input/Output (MDIO)

The management data input/output (MDIO) module continuously polls all 32 MDIO addresses to enumerate all PHY devices in the system. It contains two user access registers to control and monitor up to two PHYs simultaneously.

The MDIO module implements the 802.3 serial management interface to interrogate and control two Ethernet PHYs simultaneously using a shared two-wire bus.

6.20.1 MII Management Interface

Host software uses the MDIO module to configure the auto-negotiation parameters of each PHY attached to the Ethernet Switch Subsystem, retrieve the negotiation results, and configure required parameters in the Ethernet Switch Subsystem module for correct operation. The module is designed to allow almost transparent operation of the MDIO interface, with very little maintenance from the core processor. Only a maximum of two PHYs may be connected at any given time.

For more detailed information on the Ethernet Switch Subsystem, see the *TMS320DM647/DM648 DSP Ethernet Subsystem User's Guide Reference Guide* (literature number [SPRUF57](#)). For a list of supported registers and register fields, see [Table 6-84](#).

6.20.2 MDIO Register Descriptions

Table 6-84. MDIO Registers

HEX ADDRESS RANGE	REGISTER ACRONYM	DESCRIPTION
0x02D0 4000	MDIOVER	Module version register
0x02D0 4004	MDIOCONTROL	Module control register
0x02D0 4008	MDIOALIVE	PHY acknowledge status register
0x02D0 400C	MDIOLINK	PHY link status register
0x02D0 4010	MDIOLINKINTRAW	Link status change interrupt register (raw value)
0x02D0 4014	MDIOLINKINTMASKED	Link status change interrupt register (masked value)
0x02D0 4018 - 0x02D0 401C	reserved	
0x02D0 4020	MDIOUSERINTRAW	User command complete interrupt register (raw value)
0x02D0 4024	MDIOUSERINTMASKED	User command complete interrupt register (masked value)
0x02D0 4028	MDIOUSERINTMASKSET	User interrupt mask set register
0x02D0 402C	MDIOUSERINTMASKCLR	User interrupt mask clear register
0x02D0 4030 - 0x02D0 407C	reserved	
0x02D0 4080	MDIOUSERACCESS0	User access register0
0x02D0 4084	MDIOUSERPHYSEL0	User PHY select register0
0x02D0 4088	MDIOUSERACCESS1	User access register1
0x02D0 408C	MDIOUSERPHYSEL1	User PHY select register1
0x02D0 4090 - 0x02D0 40FF	reserved	

6.21 Timers

The device has four 64-bit general-purpose timers of which only Timer 0 and Timer 1 have external input/output. The timers can be used to: time events, count events, generate pulses, interrupt the CPU, and send synchronization events to the EDMA3 channel controller.

6.21.1 General-Purpose Timers

Each timer can be programmed as a 64-bit timer or as two separate 32-bit timers. Each timer is made up of two 32-bit counters: a high counter and a low counter. The timer pins, TINPLx and TOUTLx are connected to the low counter. The high counter does not have any external device pins.

For more detailed information, see the *TMS320DM647DM648 DSP 64-Bit Timer User's Guide* (literature number [SPRUJEL0](#)).

6.21.2 Timer Peripheral Register Descriptions

Table 6-85. Timer 0 Registers

HEX ADDRESS RANGE	ACRONYM	DESCRIPTION
0x0204 4400	PID12	Peripheral Identification Register
0x0204 4404	EMUMGT_CLKSPD	Timer 0 Emulation Management/Clock Speed Register
0x0204 4410	TIM12	Timer 0 Counter Register 12
0x0204 4414	TIM34	Timer 0 Counter Register 34
0x0204 4418	PRD12	Timer 0 Period Register 12
0x0204 441C	PRD34	Timer 0 Period Register 34
0x0204 4420	TCR	Timer 0 Control Register
0x0204 4424	TGCR	Timer 0 Global Control Register
0x0204 4428 - 0x0204 44FF	-	Reserved

Table 6-86. Timer 1 Registers

HEX ADDRESS RANGE	ACRONYM	DESCRIPTION
0x0204 4800	PID12	Peripheral Identification Register
0x0204 4804	EMUMGT_CLKSPD	Timer 1 Emulation Management/Clock Speed Register
0x0204 4810	TIM12	Timer 1 Counter Register 12
0x0204 4814	TIM34	Timer 1 Counter Register 34
0x0204 4818	PRD12	Timer 1 Period Register 12
0x0204 481C	PRD34	Timer 1 Period Register 34
0x0204 4820	TCR	Timer 1 Control Register
0x0204 4824	TGCR	Timer 1 Global Control Register
0x0204 4828 - 0x0204 48FF	-	Reserved

Table 6-87. Timer 2 Registers

HEX ADDRESS RANGE	ACRONYM	DESCRIPTION
0x0204 4C00	PID12	Peripheral Identification Register
0x0204 4C04	EMUMGT_CLKSPD	Timer 2 Emulation Management/Clock Speed Register
0x0204 4C10	TIM12	Timer 2 Counter Register 12
0x0204 4C14	TIM34	Timer 2 Counter Register 34
0x0204 4C18	PRD12	Timer 2 Period Register 12
0x0204 4C1C	PRD34	Timer 2 Period Register 34
0x0204 4C20	TCR	Timer 2 Control Register
0x0204 4C24	TGCR	Timer 2 Global Control Register
0x0204 4C28 - 0x0204 4CFF	-	Reserved

Table 6-88. Timer 3 Registers

HEX ADDRESS RANGE	ACRONYM	DESCRIPTION
0x0204 5000	PID12	Peripheral Identification Register
0x0204 5004	EMUMGT_CLKSPD	Timer 3 Emulation Management/Clock Speed Register
0x0204 5010	TIM12	Timer 3 Counter Register 12
0x0204 5014	TIM34	Timer 3 Counter Register 34
0x0204 5018	PRD12	Timer 3 Period Register 12
0x0204 501C	PRD34	Timer 3 Period Register 34
0x0204 5020	TCR	Timer 3 Control Register
0x0204 5024	TGCR	Timer 3 Global Control Register
0x0204 5028 - 0x0204 50FF	-	Reserved

6.21.3 Timer Electrical Data/Timing

Table 6-89. Timing Requirements for Timer Input⁽¹⁾ (see Figure 6-52)

NO.			720, 800, 900, 1100		UNIT
			MIN	MAX	
1	$t_{w(TIMxH)}$	Pulse duration, TIMxH high	12P ⁽¹⁾		ns
2	$t_{w(TIMxL)}$	Pulse duration, TIMxL low	12P		ns

(1) P = 1/CPU clock frequency in ns.

Table 6-90. Switching Characteristics for Timer Output

over operating free-air temperature range (unless otherwise noted)

NO.	PARAMETER	720, 800, 900, 1100			UNIT
		MIN	TYP	MAX	
3	$t_{w(TIMOxH)}$	12P ⁽¹⁾			
4	$t_{w(TIMOxL)}$	12P			

(1) P = 1/CPU clock frequency in ns.

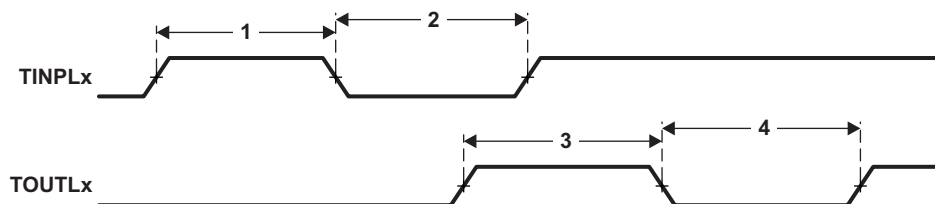

Figure 6-52. Timer Timing

6.22 VLYNQ Peripheral

6.22.1 VLYNQ Device-Specific Information

The VLYNQ peripheral conforms to the *VLYNQ Module Specification (revision 2.x)*. By default, the VLYNQ peripheral is initialized with a device ID of 0x22.

6.22.2 VLYNQ Peripheral Register Descriptions

Table 6-91. VLYNQ Registers

HEX ADDRESS RANGE	ACRONYM	REGISTER NAME
0x3800 0000	-	Reserved
0x3800 0004	CTRL	VLYNQ Local Control Register
0x3800 0008	STAT	VLYNQ Local Status Register
0x3800 000C	INTPRI	VLYNQ Local Interrupt Priority Vector Status/Clear Register
0x3800 0010	INTSTATCLR	VLYNQ Local Interrupt Status/Clear Register
0x3800 0014	INTPENDSET	VLYNQ Local Interrupt Pending/Set Register
0x3800 0018	INTPTR	VLYNQ Local Interrupt Pointer Register
0x3800 001C	XAM	VLYNQ Local Transmit Address Map
0x3800 0020	RAMS1	VLYNQ Local Receive Address Map Size 1
0x3800 0024	RAMO1	VLYNQ Local Receive Address Map Offset 1
0x3800 0028	RAMS2	VLYNQ Local Receive Address Map Size 2
0x3800 002C	RAMO2	VLYNQ Local Receive Address Map Offset 2
0x3800 0030	RAMS3	VLYNQ Local Receive Address Map Size 3
0x3800 0034	RAMO3	VLYNQ Local Receive Address Map Offset 3
0x3800 0038	RAMS4	VLYNQ Local Receive Address Map Size 4
0x3800 003C	RAMO4	VLYNQ Local Receive Address Map Offset 4
0x3800 0040	CHIPVER	VLYNQ Local Chip Version Register
0x3800 0044	AUTNGO	VLYNQ Local Auto Negotiation Register
0x3800 0048	MANNGO	VLYNQ Local Manual Negotiation Register
0x3800 004C	NGOSTAT	VLYNQ Local Negotiation Status Register
0x3800 0050 - 0x3800 005C	-	Reserved
0x3800 0060	INTVEC0	VLYNQ Local Interrupt Vector 3 - 0
0x3800 0064	INTVEC1	VLYNQ Local Interrupt Vector 7 - 4
0x3800 0068 - 0x3800 007C	-	Reserved for future use [Local Interrupt Vectors 8 - 31]
0x3800 0080	RREVID	VLYNQ Remote Revision Register
0x3800 0084	RCTRL	VLYNQ Remote Control Register
0x3800 0088	RSTAT	VLYNQ Remote Status Register
0x3800 008C	RINTPRI	VLYNQ Remote Interrupt Priority Vector Status/Clear Register
0x3800 0090	RINTSTATCLR	VLYNQ Remote Interrupt Status/Clear Register
0x3800 0094	RINTPENDSET	VLYNQ Remote Interrupt Pending/Set Register
0x3800 0098	RINTPTR	VLYNQ Remote Interrupt Pointer Register
0x3800 009C	RXAM	VLYNQ Remote Transmit Address Map
0x3800 00A0	RRAMS1	VLYNQ Remote Receive Address Map Size 1
0x3800 00A4	RRAMO1	VLYNQ Remote Receive Address Map Offset 1
0x3800 00A8	RRAMS2	VLYNQ Remote Receive Address Map Size 2
0x3800 00AC	RRAMO2	VLYNQ Remote Receive Address Map Offset 2
0x3800 00B0	RRAMS3	VLYNQ Remote Receive Address Map Size 3
0x3800 00B4	RRAMO3	VLYNQ Remote Receive Address Map Offset 3
0x3800 00B8	RRAMS4	VLYNQ Remote Receive Address Map Size 4
0x3800 00BC	RRAMO4	VLYNQ Remote Receive Address Map Offset 4

Table 6-91. VLYNQ Registers (continued)

HEX ADDRESS RANGE	ACRONYM	REGISTER NAME
0x3800 00C0	RCHIPVER	VLYNQ Remote Chip Version Register
0x3800 00C4	RAUTNGO	VLYNQ Remote Auto Negotiation Register
0x3800 00C8	RMANNGO	VLYNQ Remote Manual Negotiation Register
0x3800 00CC	RNGOSTAT	VLYNQ Remote Negotiation Status Register
0x3800 00D0 - 0x3800 00DC	-	Reserved
0x3800 00E0	RINTVEC0	VLYNQ Remote Interrupt Vector 3 - 0
0x3800 00E4	RINTVEC1	VLYNQ Remote Interrupt Vector 7 - 4
0x3800 00E8 - 0x3800 00FC	-	Reserved for future use [Remote Interrupt Vectors 8 - 31]

6.22.3 VLYNQ Electrical Data/Timing

Table 6-92. Timing Requirements for VCLK for VLYNQ (see Figure 6-53)

NO.			720, 800, 900, 1100		UNIT
			MIN	MAX	
1	$t_c(\text{VCLK})$	Cycle time, VCLK	8		ns
2	$t_w(\text{VCLKH})$	Pulse duration, VCLK high, VCLK Input	2		ns
		Pulse duration, VCLK high, VCLK Output	3		ns
3	$t_w(\text{VCLKL})$	Pulse duration, VCLK low, VCLK Input	2		ns
		Pulse duration, VCLK low, VCLK Output	3		ns
4	$t_t(\text{VCLK})$	Transition time, VCLK			ns

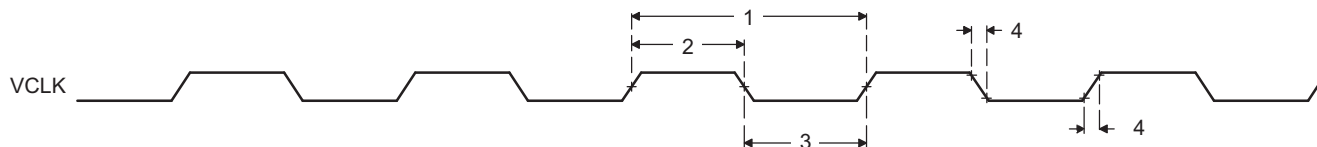

Figure 6-53. VCLK Timing for VLYNQ

Table 6-93. Switching Characteristics

Over Recommended Operating Conditions for Transmit Data for the VLYNQ Module (see [Figure 6-54](#))

NO.	PARAMETER	720, 800, 900, 1100		UNIT
		MIN	MAX	
1	$t_{d(VCLKH-TXDI)}$ Delay time, VCLK high to VTXD[3:0] invalid [SLOW Mode]	2.25		ns
1	$t_{d(VCLKH-TXDI)}$ Delay time, VCLK high to VTXD[3:0] invalid [FAST Mode]	0.86		ns
2	$t_{d(VCLKH-TXDV)}$ Delay time, VCLK to VTXD[3:0] valid		6.85	ns

Table 6-94. Timing Requirements for Receive Data for the VLYNQ Module (see [Figure 6-54](#))

NO.	PARAMETER	720, 800, 900, 1100		UNIT
		MIN	MAX	
3	$t_{su(RXDV-VCLKH)}$ Setup time, VRXD[3:0] valid before VCLK high	RTM disabled	0.2	ns
		RTM enabled, RXD Flop = 0	1.25	ns
		RTM enabled, RXD Flop = 1	0.91	ns
		RTM enabled, RXD Flop = 2	0.64	ns
		RTM enabled, RXD Flop = 3	0.36	ns
		RTM enabled, RXD Flop = 4	0.09	ns
		RTM enabled, RXD Flop = 5	-0.18	ns
		RTM enabled, RXD Flop = 6	-0.44	ns
		RTM enabled, RXD Flop = 7	-0.69	ns
4	$t_{h(VCLKH-RXDV)}$ Hold time, VRXD[3:0] valid after VCLK high	RTM disabled	2	ns
		RTM enabled, RXD Flop = 0	0.95	ns
		RTM enabled, RXD Flop = 1	1.33	ns
		RTM enabled, RXD Flop = 2	1.72	ns
		RTM enabled, RXD Flop = 3	2.15	ns
		RTM enabled, RXD Flop = 4	2.58	ns
		RTM enabled, RXD Flop = 5	3.03	ns
		RTM enabled, RXD Flop = 6	3.46	ns
		RTM enabled, RXD Flop = 7	3.89	ns

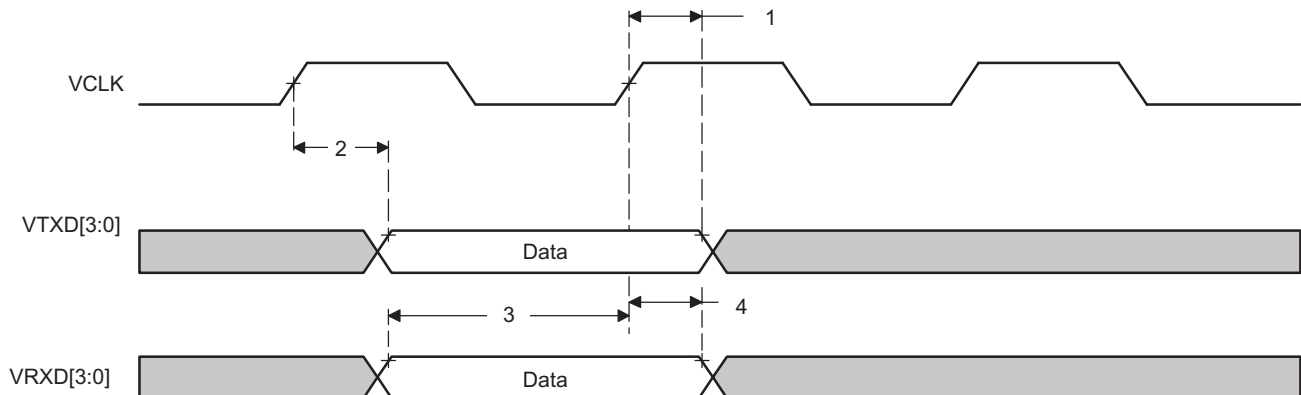

Figure 6-54. VLYNQ Transmit/Receive Timing

6.23 General-Purpose Input/Output (GPIO)

The GPIO peripheral provides general-purpose pins that can be configured as either inputs or outputs. When configured as an output, a write to an internal register can control the state driven on the output pin. When configured as an input, the state of the input is detectable by reading the state of an internal register. In addition, the GPIO peripheral can produce CPU interrupts and EDMA events in different interrupt/event generation modes. The GPIO peripheral provides generic connections to external devices. The GPIO pins are grouped into banks of 16 pins per bank (i.e., bank 0 consists of GPIO [0:15]).

The GPIO peripheral supports the following:

- Up to 3.3-V GPIO pins
- Interrupts:
 - Up to 16 unique GPIO[0:15] interrupts from Bank 0
 - One GPIO bank (aggregated) interrupt signal from the GPIOs in Bank 1
 - Interrupts can be triggered by rising and/or falling edge, specified for each interrupt capable GPIO signal
- DMA events:
 - Up to 10 unique GPIO DMA events from Bank 0
- Set/clear functionality: Firmware writes 1 to corresponding bit position(s) to set or to clear GPIO signal(s). This allows multiple firmware processes to toggle GPIO output signals without critical section protection (disable interrupts, program GPIO, re-enable interrupts, to prevent context switching to another process during GPIO programming).
- Separate Input/Output registers
- Output register in addition to set/clear so that, if preferred by firmware, some GPIO output signals can be toggled by direct write to the output register(s).
- Output register, when read, reflects output drive status. This, in addition to the input register reflecting pin status and open-drain I/O cell, allows wired logic be implemented.

The memory map for the GPIO registers is shown in [Table 6-95](#).

For more detailed information on GPIOs, see the *TMS320DM647/DM648 DSP General-Purpose Input/Output (GPIO) User's Guide* (literature number [SPRUEK7](#)).

6.23.1 GPIO Peripheral Register Descriptions

Table 6-95. GPIO Registers

HEX ADDRESS RANGE	ACRONYM	REGISTER NAME
0x0204 8000	PID	Peripheral Identification Register
0x0204 8004	-	Reserved
0x0204 8008	BINTEN	GPIO interrupt per-bank enable
GPIO Banks 0 and 1		
0x0204 800C	-	Reserved
0x0204 8010	DIR	GPIO Banks 0 and 1 Direction Register (GPIO[0:31])
0x0204 8014	OUT_DATA	GPIO Banks 0 and 1 Output Data Register (GPIO[0:31])
0x0204 8018	SET_DATA	GPIO Banks 0 and 1 Set Data Register (GPIO[0:31])
0x0204 801C	CLR_DATA	GPIO Banks 0 and 1 Clear data for banks 0 and 1 (GPIO[0:31])
0x0204 8020	IN_DATA	GPIO Banks 0 and 1 Input Data Register (GPIO[0:31])
0x0204 8024	SET_RIS_TRIG	GPIO Banks 0 and 1 Set Rising Edge Interrupt Register (GPIO[0:31])
0x0204 8028	CLR_RIS_TRIG	GPIO Banks 0 and 1 Clear Rising Edge Interrupt Register (GPIO[0:31])
0x0204 802C	SET_FAL_TRIG	GPIO Banks 0 and 1 Set Falling Edge Interrupt Register (GPIO[0:31])
0x0204 8030	CLR_FAL_TRIG	GPIO Banks 0 and 1 Clear Falling Edge Interrupt Register (GPIO[0:31])
0x0204 8034	INSTAT	GPIO Banks 0 and 1 Interrupt Status Register (GPIO[0:31])

6.23.2 GPIO Peripheral Input/Output Electrical Data/Timing

Table 6-96. Timing Requirements for GPIO Inputs⁽¹⁾ (see Figure 6-55)

NO.			720, 800, 900, 1100		UNIT
			MIN	MAX	
1	$t_{w(GPIH)}$	Pulse duration, GPIx high	12P		ns
2	$t_{w(GPIL)}$	Pulse duration, GPIx low	12P		ns

(1) The pulse width given is sufficient to generate a CPU interrupt or an EDMA event. However, if a user wants to have the device recognize the GPIx changes through software polling of the GPIO register, the GPIx duration must be extended to allow the device enough time to access the GPIO register through the internal bus. P = 1/CPU clock frequency in ns.

Table 6-97. Switching Characteristics Over Recommended Operating Conditions for GPIO Outputs (see Figure 6-55)

NO.	PARAMETER	720, 800, 900, 1100		UNIT
		MIN	MAX	
3	$t_{w(GPOH)}$	Pulse duration, GPOx high	6P ⁽¹⁾	ns
4	$t_{w(GPOL)}$	Pulse duration, GPOx low	6P ⁽¹⁾	ns

(1) This parameter value should not be used as a maximum performance specification. Actual performance of back-to-back accesses of the GPIO is dependent upon internal bus activity. P = 1/CPU clock frequency in ns.

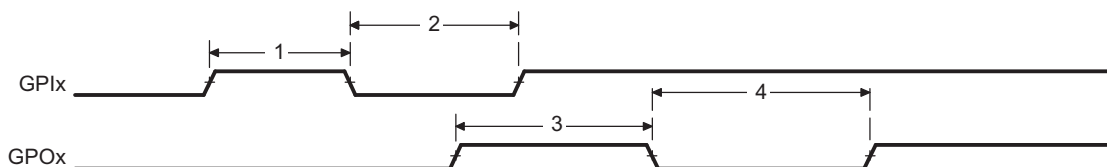

Figure 6-55. GPIO Port Timing

6.24 Emulation Features and Capability

6.24.1 Advanced Event Triggering (AET)

The device supports Advanced Event Triggering (AET). This capability can be used to debug complex problems as well as understand performance characteristics of user applications. AET provides the following capabilities:

- **Hardware Program Breakpoints:** specify addresses or address ranges that can generate events such as halting the processor or triggering the trace capture.
- **Data Watchpoints:** specify data variable addresses, address ranges, or data values that can generate events such as halting the processor or triggering the trace capture.
- **Counters:** count the occurrence of an event or cycles for performance monitoring.
- **State Sequencing:** allows combinations of hardware program breakpoints and data watchpoints to precisely generate events for complex sequences.

For more information on AET, see the following documents:

- *Using Advanced Event Triggering to Find and Fix Intermittent Real-Time Bugs Application Report* (literature number [SPRA753](#))
- *Using Advanced Event Triggering to Debug Real-Time Problems in High Speed Embedded Microprocessor Systems Application Report* (literature number [SPRA387](#))

6.24.2 Trace

The device supports Trace. Trace is a debug technology that provides a detailed, historical account of application code execution, timing, and data accesses. Trace collects, compresses, and exports debug information for analysis. Trace works in real-time and does not impact the execution of the system.

For more information on board design guidelines for Trace Advanced Emulation, see the *Emulation and Trace Headers Technical Reference Manual* (literature number [SPRU655](#)).

6.25 IEEE 1149.1 JTAG

The JTAG ⁽²⁾ interface is used for BSDL testing and emulation of the device.

$\overline{\text{TRST}}$ needs to be released only when it is necessary to use a JTAG controller to debug the device or exercise the device's boundary scan functionality. Note: $\overline{\text{TRST}}$ is synchronous and **must** be clocked by TCK; otherwise, the boundary scan logic may not respond as expected after $\overline{\text{TRST}}$ is asserted.

For maximum reliability, the device includes an internal pulldown (IPD) on the $\overline{\text{TRST}}$ pin to make certain that $\overline{\text{TRST}}$ will always be asserted upon power up and the device's internal emulation logic will always be properly initialized.

JTAG controllers from Texas Instruments actively drive $\overline{\text{TRST}}$ high. However, some third-party JTAG controllers may not drive $\overline{\text{TRST}}$ high but expect the use of a pullup resistor on $\overline{\text{TRST}}$.

When using this type of JTAG controller, assert $\overline{\text{TRST}}$ to initialize the device after powerup and externally drive $\overline{\text{TRST}}$ high before attempting any emulation or boundary scan operations.

6.25.1 JTAG Peripheral Register Description(s) - JTAG ID Register

Table 6-98. JTAG ID Register

HEX ADDRESS RANGE	ACRONYM	REGISTER NAME	COMMENTS
0x0204 9018	JTAGID	JTAG Identification Register	Read-only. Provides 32-bit JTAG ID of the device.

(2) IEEE Standard 1149.1-1990 Standard-Test-Access Port and Boundary Scan Architecture.

The JTAG ID register is a read-only register that identifies to the customer the JTAG/Device ID. The JTAG ID register resides at address location 0x0204 9018. The register hex value is: 0x0B77 A02F . For the actual register bit names and their associated bit field descriptions, see [Figure 6-56](#) and [Table 6-99](#).

Figure 6-56. JTAGID Register (0x0204 9018)

31-28	27-12	11-1	0
VERSION	PART NUMBER (16-Bit)	MANUFACTURER (11-Bit)	LSB
R-0001	R-1011 0111 0111 1010	R-0000 0010 111	R-1

LEGEND: R = Read, W = Write, n = value at reset

Table 6-99. JTAGID Register Selection Bit Descriptions

BIT	NAME	DESCRIPTION
31:28	VERSION	Silicon version value: 0001.
27:12	PART NUMBER	Part Number (16-Bit) value: 1011 0111 0111 1010.
11-1	MANUFACTURER	Manufacturer (11-Bit) value: 0000 0010 111.
0	LSB	LSB. This bit is read as a 1.

6.25.2 JTAG Electrical Data/Timing

Table 6-100. Timing Requirements for JTAG Test Port (see [Figure 6-57](#))

NO.			720, 800, 900, 1100		UNIT
			MIN	MAX	
1	$t_c(\text{TCK})$	Cycle time, TCK	35		ns
3	$t_{su}(\text{TDIV-TCKH})$	Setup time, TDI/TMS/ $\overline{\text{TRST}}$ valid before TCK high	2		ns
4	$t_h(\text{TCKH-TDIV})$	Hold time, TDI/TMS/ $\overline{\text{TRST}}$ valid after TCK high	0		ns

Table 6-101. Switching Characteristics Over Recommended Operating Conditions for JTAG Test Port
(see [Figure 6-57](#))

NO.	PARAMETER	720, 800, 900, 1100		UNIT
		MIN	MAX	
2	$t_{d(TCKL-TDOV)}$ Delay time, TCK low to TDO valid	0	$0.25 \times t_{c(TCK)}$	ns

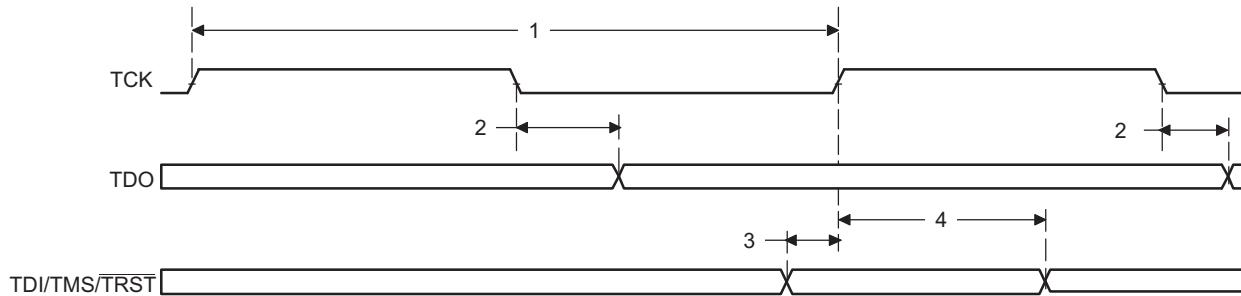

Figure 6-57. JTAG Test-Port Timing

7 Mechanical Data

The following table(s) show the thermal resistance characteristics for the ZUT mechanical package.

7.1 Thermal Data for ZUT

Table 7-1. Thermal Resistance Characteristics (PBGA Package) [ZUT]

		°C/W ⁽¹⁾	AIR FLOW (m/s) ⁽²⁾
R θ _{JC}	R θ _{JC} Junction-to-case	1.7	N/A
R θ _{JB}	R θ _{JB} Junction-to-board	8.6	N/A
R θ _{JA}	R θ _{JA} Junction-to-free air	17.2	0.0
		13.7	1.0
		12.4	2.0
		11.5	3.0
ψ _{JT}	ψ _{JT} Junction-to-package top	0.6	0.0
		0.6	1.0
		0.6	2.0
		0.7	3.0
ψ _{JB}	ψ _{JB} Junction-to-board	8.4	0.0
		7.4	1.0
		7.0	2.0
		6.7	3.0

(1) The junction-to-case measurement was conducted in a JEDEC defined 1S0P system. Other measurements were conducted in a JEDEC defined 1S2P system and will change based on environment as well as application.

For more information, see these three EIA/JEDEC standards:

- EIA/JESD51-2, *Integrated Circuits Thermal Test Method Environment Conditions - Natural Convection (Still Air)*
- EIA/JESD51-3, *Low Effective Thermal Conductivity Test Board for Leaded Surface Mount Packages*
- JESD51-9, *Test Boards for Area Array Surface Mount Package Thermal Measurements*

(2) m/s = meters per second

7.2 Packaging Information

The following packaging information and addendum reflects the most current data available for the designated device(s). This data is subject to change without notice and without revision of this document.

PACKAGING INFORMATION

Orderable Device	Status (1)	Package Type	Package Drawing	Pins	Package Qty	Eco Plan (2)	Lead finish/ Ball material (6)	MSL Peak Temp (3)	Op Temp (°C)	Device Marking (4/5)	Samples
TMS320DM647CUT9	NRND	FCBGA	CUT	529		RoHS & Green	Call TI	Level-4-245C-72HR	0 to 0	TMS320DM647CUT @2007 T1 900MHZ	
TMS320DM647CUTA6	NRND	FCBGA	CUT	529		TBD	Call TI	Call TI			
TMS320DM647CUTA8	NRND	FCBGA	CUT	529		TBD	Call TI	Call TI	0 to 0		
TMS320DM647CUTD7	NRND	FCBGA	CUT	529		RoHS & Green	Call TI	Level-4-245C-72HR	0 to 0	TMS320DM647CUT @2007 T1 D720MHZ	
TMS320DM647CUTD9	NRND	FCBGA	CUT	529		RoHS & Green	Call TI	Level-4-245C-72HR	-40 to 90	TMS320DM647CUT @2007 T1 D900MHZ	
TMS320DM648CUT7	ACTIVE	FCBGA	CUT	529	84	RoHS & Green	Call TI	Level-4-245C-72HR	0 to 90	TMS320DM648CUT @2007 T1 720MHZ	Samples
TMS320DM648CUT9	ACTIVE	FCBGA	CUT	529	84	RoHS & Green	Call TI	Level-4-245C-72HR	0 to 90	TMS320DM648CUT @2007 T1 900MHZ	Samples
TMS320DM648CUTA8	ACTIVE	FCBGA	CUT	529	84	RoHS & Green	Call TI	Level-4-245C-72HR	-40 to 105	TMS320DM648CUT @2007 T1 A800MHZ	Samples
TMS320DM648CUTD7	ACTIVE	FCBGA	CUT	529	84	RoHS & Green	Call TI	Level-4-245C-72HR	-40 to 90	TMS320DM648CUT @2007 T1 D720MHZ	Samples

(1) The marketing status values are defined as follows:

ACTIVE: Product device recommended for new designs.

LIFEBUY: TI has announced that the device will be discontinued, and a lifetime-buy period is in effect.

NRND: Not recommended for new designs. Device is in production to support existing customers, but TI does not recommend using this part in a new design.

PREVIEW: Device has been announced but is not in production. Samples may or may not be available.

OBSOLETE: TI has discontinued the production of the device.

(2) **RoHS:** TI defines "RoHS" to mean semiconductor products that are compliant with the current EU RoHS requirements for all 10 RoHS substances, including the requirement that RoHS substance do not exceed 0.1% by weight in homogeneous materials. Where designed to be soldered at high temperatures, "RoHS" products are suitable for use in specified lead-free processes. TI may reference these types of products as "Pb-Free".

RoHS Exempt: TI defines "RoHS Exempt" to mean products that contain lead but are compliant with EU RoHS pursuant to a specific EU RoHS exemption.

Green: TI defines "Green" to mean the content of Chlorine (Cl) and Bromine (Br) based flame retardants meet JS709B low halogen requirements of ≤ 1000 ppm threshold. Antimony trioxide based flame retardants must also meet the ≤ 1000 ppm threshold requirement.

(3) MSL, Peak Temp. - The Moisture Sensitivity Level rating according to the JEDEC industry standard classifications, and peak solder temperature.

(4) There may be additional marking, which relates to the logo, the lot trace code information, or the environmental category on the device.

(5) Multiple Device Markings will be inside parentheses. Only one Device Marking contained in parentheses and separated by a "~" will appear on a device. If a line is indented then it is a continuation of the previous line and the two combined represent the entire Device Marking for that device.

(6) Lead finish/Ball material - Orderable Devices may have multiple material finish options. Finish options are separated by a vertical ruled line. Lead finish/Ball material values may wrap to two lines if the finish value exceeds the maximum column width.

Important Information and Disclaimer: The information provided on this page represents TI's knowledge and belief as of the date that it is provided. TI bases its knowledge and belief on information provided by third parties, and makes no representation or warranty as to the accuracy of such information. Efforts are underway to better integrate information from third parties. TI has taken and continues to take reasonable steps to provide representative and accurate information but may not have conducted destructive testing or chemical analysis on incoming materials and chemicals. TI and TI suppliers consider certain information to be proprietary, and thus CAS numbers and other limited information may not be available for release.

In no event shall TI's liability arising out of such information exceed the total purchase price of the TI part(s) at issue in this document sold by TI to Customer on an annual basis.

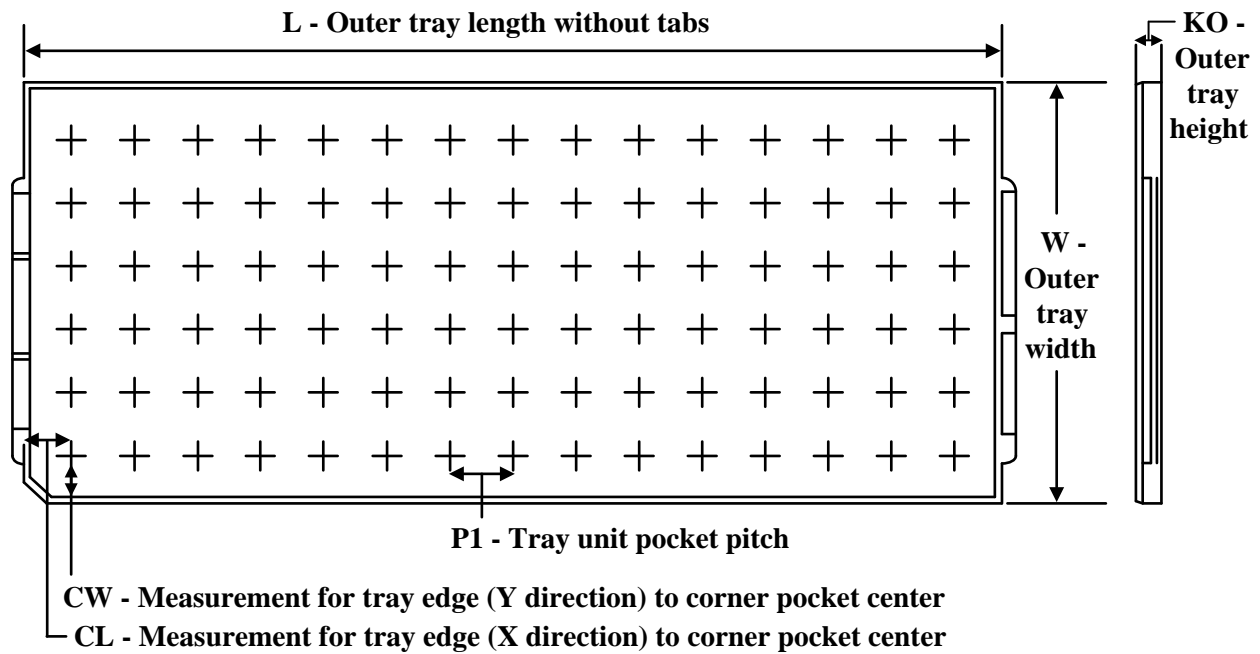
TRAY

Chamfer on Tray corner indicates Pin 1 orientation of packed units.

*All dimensions are nominal

Device	Package Name	Package Type	Pins	SPQ	Unit array matrix	Max temperature (°C)	L (mm)	W (mm)	K0 (µm)	P1 (mm)	CL (mm)	CW (mm)
TMS320DM648CUT7	CUT	FCBGA	529	84	6X14	150	315	135.9	7620	21.34	18.79	14.6
TMS320DM648CUT9	CUT	FCBGA	529	84	6X14	150	315	135.9	7620	21.34	18.79	14.6
TMS320DM648CUTA8	CUT	FCBGA	529	84	6X14	150	315	135.9	7620	21.34	18.79	14.6

MECHANICAL DATA

ZUT (S-PBGA-N529)

PLASTIC BALL GRID ARRAY

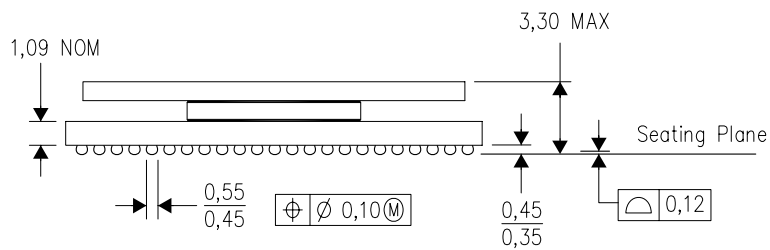
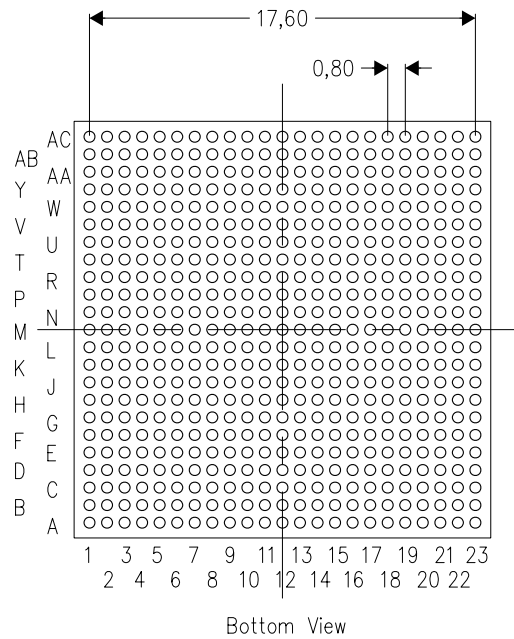
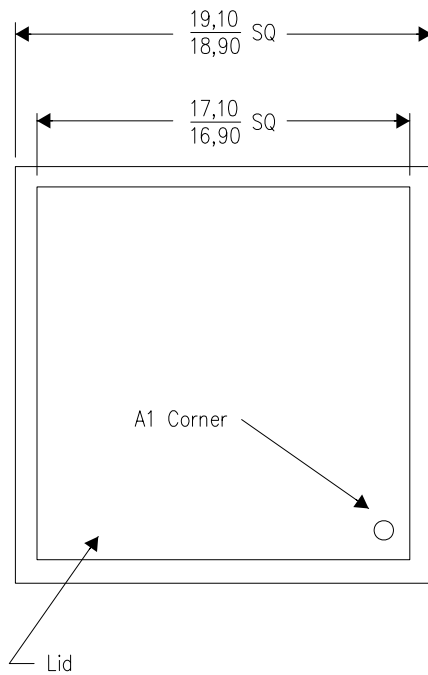

4207941/C 02/10

- NOTES:
- A. All linear dimensions are in millimeters. Dimensioning and tolerancing per ASME Y14.5M-1994.
 - B. This drawing is subject to change without notice.
 - C. Thermally enhanced package with lid.
 - D. Flip chip application only.
 - E. This is a Pb-free solder ball design.

IMPORTANT NOTICE AND DISCLAIMER

TI PROVIDES TECHNICAL AND RELIABILITY DATA (INCLUDING DATA SHEETS), DESIGN RESOURCES (INCLUDING REFERENCE DESIGNS), APPLICATION OR OTHER DESIGN ADVICE, WEB TOOLS, SAFETY INFORMATION, AND OTHER RESOURCES "AS IS" AND WITH ALL FAULTS, AND DISCLAIMS ALL WARRANTIES, EXPRESS AND IMPLIED, INCLUDING WITHOUT LIMITATION ANY IMPLIED WARRANTIES OF MERCHANTABILITY, FITNESS FOR A PARTICULAR PURPOSE OR NON-INFRINGEMENT OF THIRD PARTY INTELLECTUAL PROPERTY RIGHTS.

These resources are intended for skilled developers designing with TI products. You are solely responsible for (1) selecting the appropriate TI products for your application, (2) designing, validating and testing your application, and (3) ensuring your application meets applicable standards, and any other safety, security, regulatory or other requirements.

These resources are subject to change without notice. TI grants you permission to use these resources only for development of an application that uses the TI products described in the resource. Other reproduction and display of these resources is prohibited. No license is granted to any other TI intellectual property right or to any third party intellectual property right. TI disclaims responsibility for, and you will fully indemnify TI and its representatives against, any claims, damages, costs, losses, and liabilities arising out of your use of these resources.

TI's products are provided subject to [TI's Terms of Sale](#) or other applicable terms available either on ti.com or provided in conjunction with such TI products. TI's provision of these resources does not expand or otherwise alter TI's applicable warranties or warranty disclaimers for TI products.

TI objects to and rejects any additional or different terms you may have proposed.

Mailing Address: Texas Instruments, Post Office Box 655303, Dallas, Texas 75265
Copyright © 2022, Texas Instruments Incorporated