

# Customer Information Sheet

DRAWING No.: R6405-00 - R6436-00

IF IN DOUBT - ASK

©

NOT TO SCALE

THIRD ANGLE PROJECTION

ALL DIMENSIONS IN mm

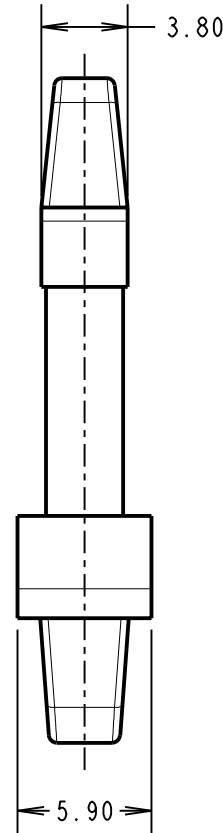

TO FIT  $\varnothing 4.0\text{mm}$  HOLE  
( $\varnothing 4.8\text{mm}$  ON R4636-00)

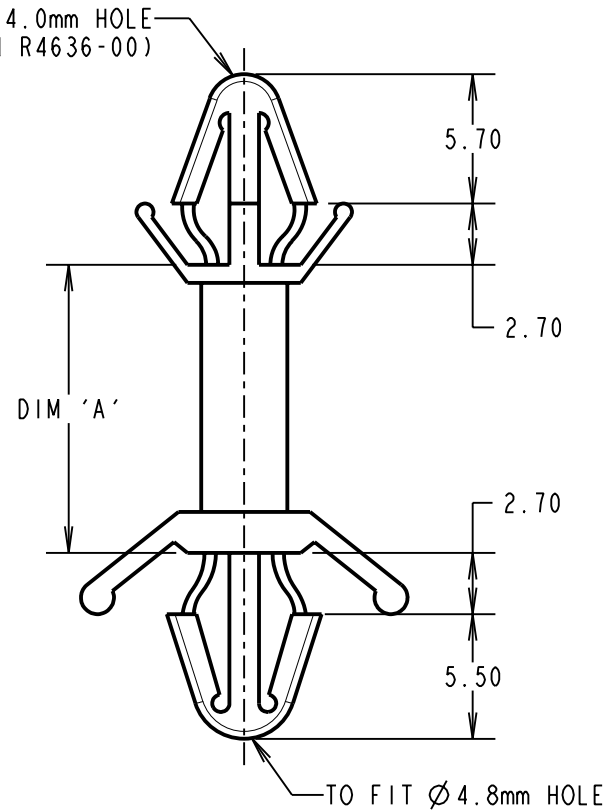

PART No.	DIM 'A'
R6405-00	4.80
R6406-00	6.40
R6410-00	9.60
R6413-00	12.70
R6416-00	15.90
R6419-00	19.10
R6422-00	22.20
R6425-00	25.40
R6428-00	28.50
R6435-00	35.00
R6436-00	35.00

ORDER CODE:

**R64XX-00**

SIZE CODE  
(SEE TABLE)

**NOTES:**

1. ALL TOLERANCES ARE  $\pm 0.50$  UNLESS OTHERWISE STATED.
2. TEMPERATURE RANGE =  $-40^{\circ}\text{C}$  TO  $+85^{\circ}\text{C}$ .

CP	5	08.03.10	10702
NAME	ISS.	DATE	C/NOTE
APPROVED: C.PENROSE			
CHECKED: R.ADDE			
DRAWN: D.BECK			
CUSTOMER REF.:			
ASSEMBLY DRG:			

**HARWIN**

HARWIN USA  
TEL: 603 893 5376  
FAX: 603 893 5396  
mis@harwin.com

HARWIN Europe (UK)  
TEL: 023 9231 4545  
FAX: 023 9231 4590  
mis@harwin.co.uk

HARWIN Asia  
TEL: +65 6 779 4909  
FAX: +65 6 779 3868  
mis@harwin.com.sg

THIS DRAWING AND ANY INFORMATION OR DESCRIPTIVE MATTER SET OUT HEREON ARE CONFIDENTIAL AND COPYRIGHT PROPERTY OF THE HARWIN GROUP AND MUST NOT BE DISCLOSED, LOANED, COPIED OR USED FOR MANUFACTURING, TENDERING OR FOR ANY OTHER PURPOSE WITHOUT THEIR WRITTEN PERMISSION.

**TOLERANCES**  
X =  $\pm 1\text{mm}$   
X.X =  $\pm 0.25\text{mm}$   
X.XX =  $\pm 0.10\text{mm}$   
X.XXX =  $\pm 0.01\text{mm}$   
ANGLES =  $\pm 5^{\circ}$   
UNLESS STATED

**MATERIAL:**  
NYLON 66 NATURAL UL94V-2  
**FINISH:** CLEAN  
**S/AREA:** mm<sup>2</sup>

**TITLE:**  
SELF LOCKING  
SUPPORT SPACER  
**DRAWING NUMBER:**  
R6405-00 - R6436-00