

Evaluating the **AD8235** 40 μ A, Micropower Instrumentation Amplifier

FEATURES

- Simple evaluation of the **AD8235**
- CR2032 battery provision
- On-board voltage reference using the **LTC2063** low power amplifier
- 2 in \times 1.35 in small form factor

APPLICATIONS

- Fast and easy product evaluation and characterization
- Portable system applications

GENERAL DESCRIPTION

The AD8235ACBZ-EVALZ contains a CR2032 battery provision that is capable of powering up the **AD8235** 40 μ A, micropower instrumentation amplifier and the **LTC2063** low power operational amplifier. This feature allows the AD8235ACBZ-EVALZ to be a standalone board ready for product evaluation.

The AD8235ACBZ-EVALZ design allows the user to easily adjust the gain resistors and common discrete components on the board. The on-board male headers set the AD8235ACBZ-EVALZ to different configurations using the jumper shunt.

The AD8235ACBZ-EVALZ allows battery-powered configuration to showcase the portable nature of the **AD8235**. In battery-powered configuration, the **LTC2063** acts as the voltage reference for the single-supply configuration.

For full details on the **AD8235**, see the **AD8235** data sheet, which must be consulted in conjunction with this user guide when using the AD8235ACBZ-EVALZ.

TABLE OF CONTENTS

Features	1	On-Board AD8235	4
Applications	1	Component Locations	4
General Description	1	Load Resistor	4
Revision History	2	AD8235ACBZ-EVALZ Schematic and Artwork	5
Evaluation Board Photograph	3	Ordering Information	6
Evaluation Board Hardware	4	Bill of Materials	6
Single-Supply Operation	4		

REVISION HISTORY

8/2019—Revision 0: Initial Version

EVALUATION BOARD PHOTOGRAPH

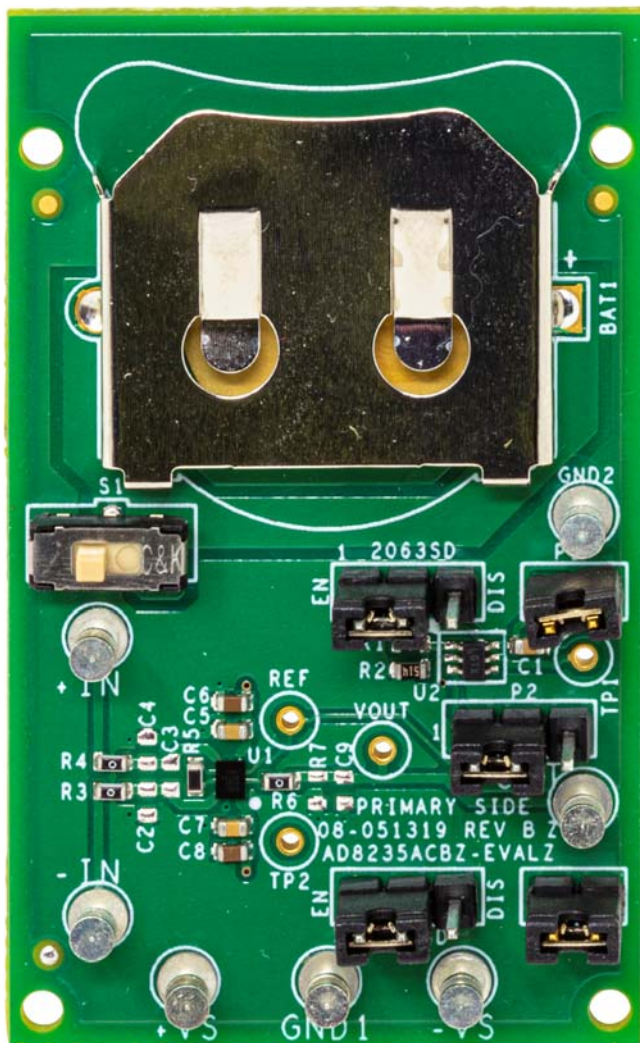

Figure 1.

EVALUATION BOARD HARDWARE

SINGLE-SUPPLY OPERATION

A switch (S1) is provided on the AD8235ACBZ-EVALZ to select either a battery-powered configuration or an external supply configuration. The AD8235ACBZ-EVALZ is shipped in battery operated single-supply mode and is configured on the P2, P3, and P5 jumpers.

ON-BOARD AD8235

The AD8235 shutdown pin (SDN) can allow continuous operation of the AD8235, or this pin can interface to allow a microcontroller to be set when the AD8235 must operate in shutdown mode to conserve further energy.

Gain Adjustment

The AD8235 gain is pin-selectable where the gain (G) = 5 (default) and where the gain resistor (R_G) is unpopulated. The AD8235 gain is resistor dependent. The resistor is connected between the RG pins. Table 1 provides calculated gains for the AD8235. See the AD8235 data sheet for the gain equation.

Table 1. AD8235 Gain Resistor Values

1% Standard Value of R_G (k Ω)	Calculated Gain
422	6.0
210	7.0
140	8.0
105	9.0
84.5	10.0
28	20.0
9.31	50.1
4.42	100.0
2.15	200.3

Table 2. Jumpers and Switch Configuration Options

Jumper	Function	Default Position
8235SD	Allows the AD8235 SDN pin to connect to either the +VS input or the -VS input on the AD8235ACBZ-EVALZ.	EN
2063SD	Allows the LTC2063 $\overline{\text{SHDN}}$ pin to connect to either the +VS input or the GND1 input on the AD8235ACBZ-EVALZ.	EN
P1	Connects the LTC2063 V^+ pin to the power supply to power up the LTC2063.	Installed
P2	Allows the AD8235 REF pin to connect to either the LTC2063 OUT pin or the GND1 pin on the AD8235ACBZ-EVALZ.	Position 1, connected to the LTC2063 OUT pin
P3	Connects the AD8235 $-V_S$ pin to the GND1 pin on the AD8235ACBZ-EVALZ for single-supply operation.	Installed
S1	Allows the AD8235ACBZ-EVALZ to be powered up by the CR2032 battery.	Position 1, battery not connected to the AD8235 +VS pin or the LTC2063 V^+ pin

Table 3. AD8235ACBZ-EVALZ Input/Output Pins and Function Descriptions

Input/Output Pin	Function
+VS and -VS	Positive and negative rails of the amplifiers.
GND1 and GND2	Ground for the board.
+IN and -IN	Positive and negative AD8235 inputs.
REF	Reference input for the AD8235.
VOUT	AD8235 output.

COMPONENT LOCATIONS

See Figure 4 for the AD8235ACBZ-EVALZ component layout, connector locations, and male header locations.

LOAD RESISTOR

Although not required for normal operation, a load resistor can be inserted at Position R7.

Voltage Reference or Offset Adjustment

The default configuration of the AD8235ACBZ-EVALZ reference is set on the midsupply level driven by the LTC2063. The on-board voltage reference can be set at the P2 jumper to power up the LTC2063, and at the P3 jumper to connect the LTC2063 OUT pin to the AD8235 REF pin. See Figure 2 for the schematic design of the on-board voltage reference.

The LTC2063 features a shutdown control pin ($\overline{\text{SHDN}}$) to disable the device. The 2063SD header on the AD8235ACBZ-EVALZ connects the LTC2063 $\overline{\text{SHDN}}$ pin to either the +VS pin or the GND1 pin of the AD8235ACBZ-EVALZ, and can interface to a microcontroller. See Table 2 for the LTC2063 options.

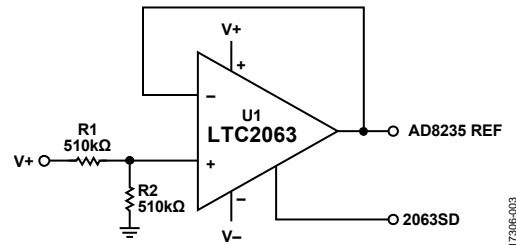

Figure 2. On-Board Voltage Reference

AD8235ACBZ-EVALZ SCHEMATIC AND ARTWORK

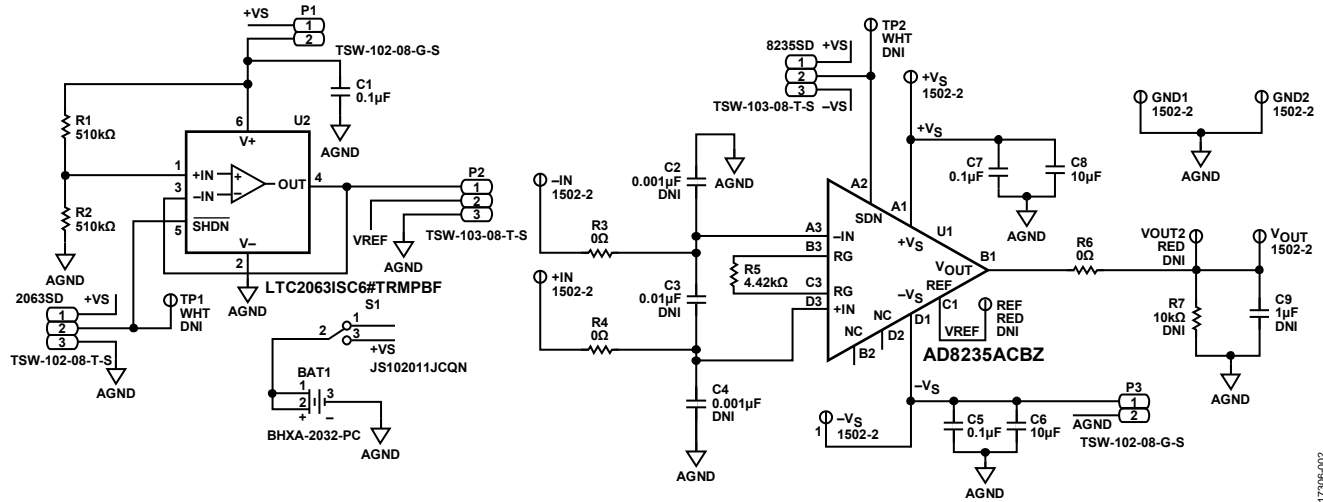

Figure 3. AD8235ACBZ-EVALZ Schematic

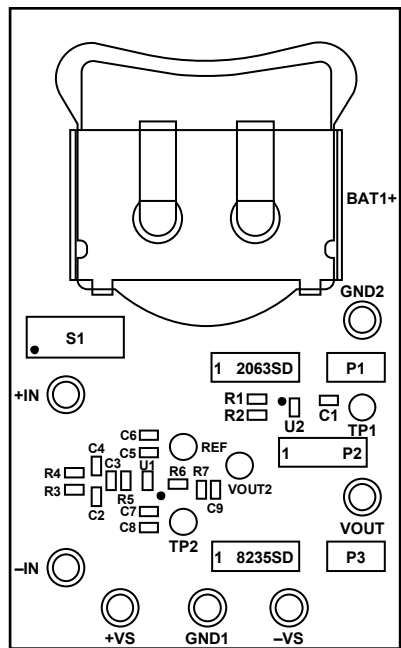

Figure 4. AD8235ACBZ-EVALZ Components

ORDERING INFORMATION

BILL OF MATERIALS

Table 4.

Reference Designator	Description	Manufacturer	Part Number
R5	Precision thin film chip resistor, 4.42 k Ω , R0603	Panasonic	ERJ-3EKF4421V
R1, R2	Precision thin film chip resistors, 510 k Ω , R0603	TE Connectivity	CPF0603B510KE1
R3, R4, R6	Surface mount device (SMD) resistor chips, 0 Ω , R0603	Vishay	CRCW0603000ZRT1
C6, C8	X5R ceramic capacitors, 10 μ F, R0603	TDK	C1608X5R1A106K080AC
C1, C5, C7	X7R ceramic capacitors, 0.1 μ F, R0603	Kemet	C0603C104K4RAC
P1, P3	2-position, male printed circuit board (PCB) headers	SAMTEC	TSW-102-08-G-S
P2, 8235SD, 2063SD	3-position, male PCB headers	SAMTEC	TSW-103-08-T-S
S1	Subminiature single-pole double throw (SPDT) switch	C&K	JS102011JCQN
+VS, -VS, +IN, -IN, GND1, GND2, VOUT	Turret style test points	Keystone Electronics	1502-2
BAT1	CR2032 battery holder	Memory Protection Devices	BHX1-2032-PC
U2	Low bias current (I_b), zero drift operational amplifier	Analog Devices	LTC2063ISC6#TRMPBF
U1	Micropower instrumentation amplifier, 40 μ A	Analog Devices	AD8235ACBZ-P7

**ESD Caution**

ESD (electrostatic discharge) sensitive device. Charged devices and circuit boards can discharge without detection. Although this product features patented or proprietary protection circuitry, damage may occur on devices subjected to high energy ESD. Therefore, proper ESD precautions should be taken to avoid performance degradation or loss of functionality.

Legal Terms and Conditions

By using the evaluation board discussed herein (together with any tools, components documentation or support materials, the "Evaluation Board"), you are agreeing to be bound by the terms and conditions set forth below ("Agreement") unless you have purchased the Evaluation Board, in which case the Analog Devices Standard Terms and Conditions of Sale shall govern. Do not use the Evaluation Board until you have read and agreed to the Agreement. Your use of the Evaluation Board shall signify your acceptance of the Agreement. This Agreement is made by and between you ("Customer") and Analog Devices, Inc. ("ADI"), with its principal place of business at One Technology Way, Norwood, MA 02062, USA. Subject to the terms and conditions of the Agreement, ADI hereby grants to Customer a free, limited, personal, temporary, non-exclusive, non-sublicensable, non-transferable license to use the Evaluation Board FOR EVALUATION PURPOSES ONLY. Customer understands and agrees that the Evaluation Board is provided for the sole and exclusive purpose referenced above, and agrees not to use the Evaluation Board for any other purpose. Furthermore, the license granted is expressly made subject to the following additional limitations: Customer shall not (i) rent, lease, display, sell, transfer, assign, sublicense, or distribute the Evaluation Board; and (ii) permit any Third Party to access the Evaluation Board. As used herein, the term "Third Party" includes any entity other than ADI, Customer, their employees, affiliates and in-house consultants. The Evaluation Board is NOT sold to Customer; all rights not expressly granted herein, including ownership of the Evaluation Board, are reserved by ADI. CONFIDENTIALITY. This Agreement and the Evaluation Board shall all be considered the confidential and proprietary information of ADI. Customer may not disclose or transfer any portion of the Evaluation Board to any other party for any reason. Upon discontinuation of use of the Evaluation Board or termination of this Agreement, Customer agrees to promptly return the Evaluation Board to ADI. ADDITIONAL RESTRICTIONS. Customer may not disassemble, decompile or reverse engineer chips on the Evaluation Board. Customer shall inform ADI of any occurred damages or any modifications or alterations it makes to the Evaluation Board, including but not limited to soldering or any other activity that affects the material content of the Evaluation Board. Modifications to the Evaluation Board must comply with applicable law, including but not limited to the RoHS Directive. TERMINATION. ADI may terminate this Agreement at any time upon giving written notice to Customer. Customer agrees to return to ADI the Evaluation Board at that time. LIMITATION OF LIABILITY. THE EVALUATION BOARD PROVIDED HEREUNDER IS PROVIDED "AS IS" AND ADI MAKES NO WARRANTIES OR REPRESENTATIONS OF ANY KIND WITH RESPECT TO IT. ADI SPECIFICALLY DISCLAIMS ANY REPRESENTATIONS, ENDORSEMENTS, GUARANTEES, OR WARRANTIES, EXPRESS OR IMPLIED, RELATED TO THE EVALUATION BOARD INCLUDING, BUT NOT LIMITED TO, THE IMPLIED WARRANTY OF MERCHANTABILITY, TITLE, FITNESS FOR A PARTICULAR PURPOSE OR NON-INFRINGEMENT OF INTELLECTUAL PROPERTY RIGHTS. IN NO EVENT WILL ADI AND ITS LICENSORS BE LIABLE FOR ANY INCIDENTAL, SPECIAL, INDIRECT, OR CONSEQUENTIAL DAMAGES RESULTING FROM CUSTOMER'S POSSESSION OR USE OF THE EVALUATION BOARD, INCLUDING BUT NOT LIMITED TO LOST PROFITS, DELAY COSTS, LABOR COSTS OR LOSS OF GOODWILL. ADI'S TOTAL LIABILITY FROM ANY AND ALL CAUSES SHALL BE LIMITED TO THE AMOUNT OF ONE HUNDRED US DOLLARS (\$100.00). EXPORT. Customer agrees that it will not directly or indirectly export the Evaluation Board to another country, and that it will comply with all applicable United States federal laws and regulations relating to exports. GOVERNING LAW. This Agreement shall be governed by and construed in accordance with the substantive laws of the Commonwealth of Massachusetts (excluding conflict of law rules). Any legal action regarding this Agreement will be heard in the state or federal courts having jurisdiction in Suffolk County, Massachusetts, and Customer hereby submits to the personal jurisdiction and venue of such courts. The United Nations Convention on Contracts for the International Sale of Goods shall not apply to this Agreement and is expressly disclaimed.