

Customer Information Sheet

DRAWING No.: H218X-XX

IF IN DOUBT - ASK

©

NOT TO SCALE

THIRD ANGLE PROJECTION

ALL DIMENSIONS IN mm

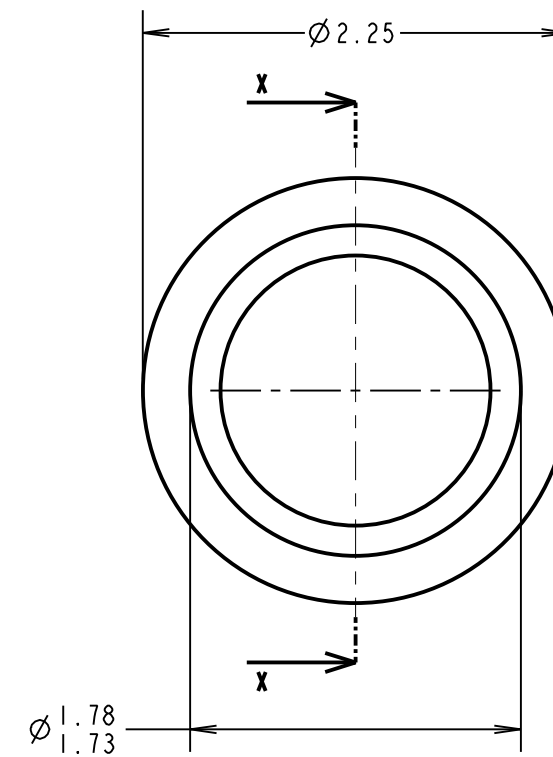
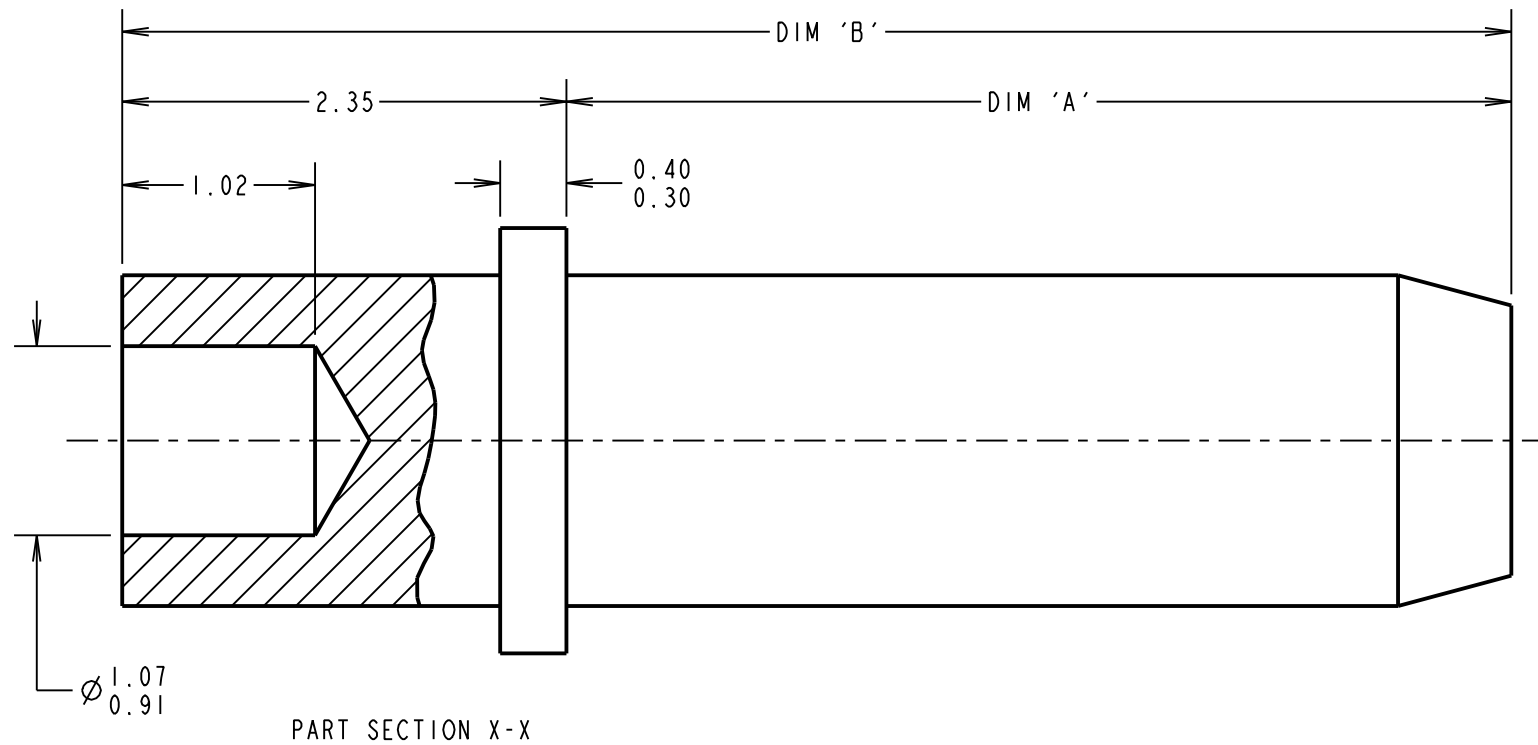

PART No.	FINISH	DIM 'A'	DIM 'B'
H2181-01	100% TIN OVER NICKEL	5.00	7.35
H2181-05	GOLD		
H2182-01	100% TIN OVER NICKEL	8.10	10.45
H2182-05	GOLD		
H2183-01	100% TIN OVER NICKEL	9.50	11.85
H2183-05	GOLD		
H2184-01	100% TIN OVER NICKEL	15.30	17.65
H2184-05	GOLD		
H2185-01	100% TIN OVER NICKEL	21.65	24.00
H2185-05	GOLD		

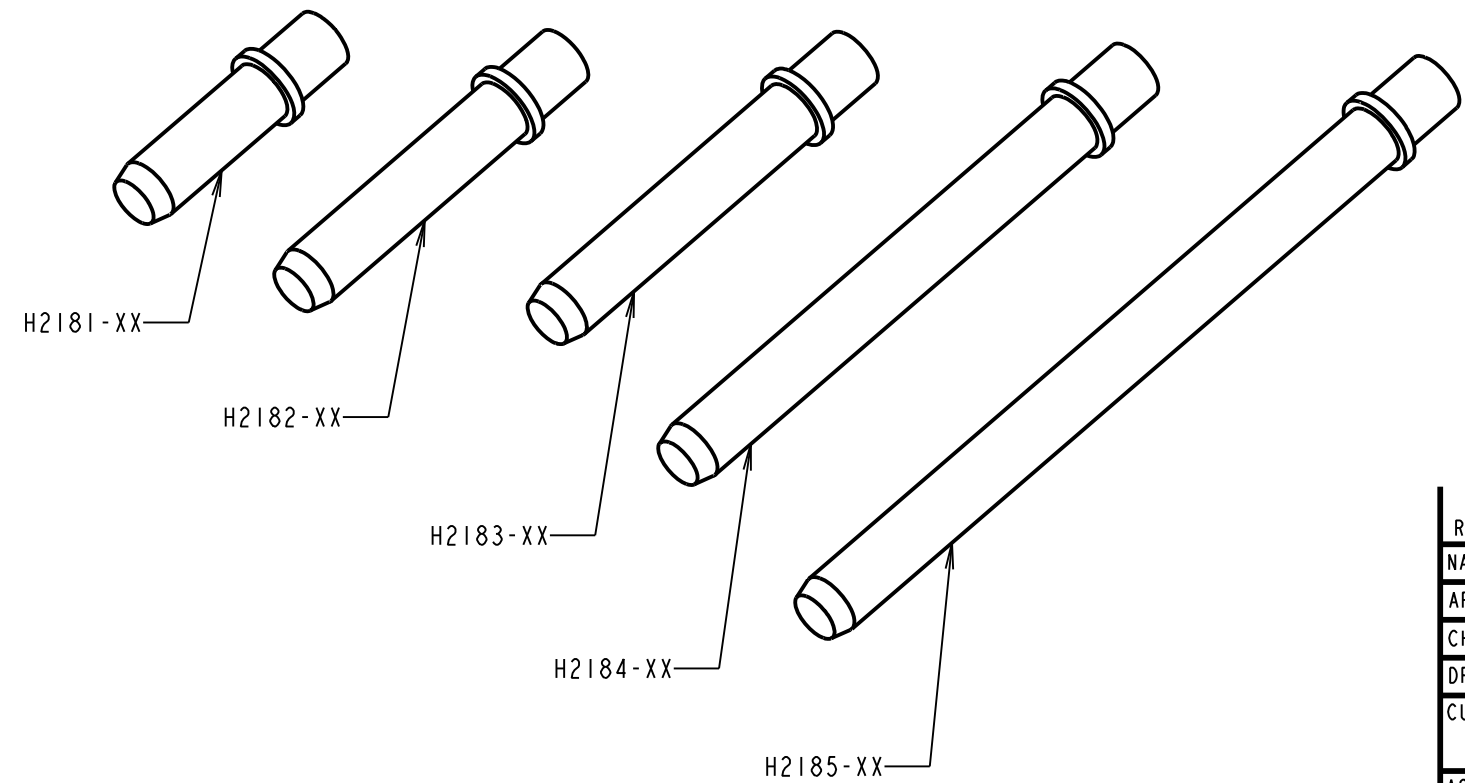

ORDER CODE:
H218X-XX
 SEE TABLE ——— FINISH:
 01 = TIN
 05 = GOLD

RTP	2	08.01.21	30335
NAME	ISS.	DATE	CN/CO
APPROVED: S.BENNETT			
CHECKED: R.ALEXANDER			
DRAWN: R.PORTLOCK			
CUSTOMER REF.:			
ASSEMBLY DRG:			

NOTES:
 1. RECOMMENDED MOUNTING HOLE SIZE = \varnothing 1.80-1.90mm.
 2. COMPONENTS WILL BE SUPPLIED BULK PACKED IN BAGS.

HARWIN
 www.harwin.com
 technical@harwin.com

THIS DRAWING AND ANY INFORMATION OR DESCRIPTIVE MATTER SET OUT HEREON ARE CONFIDENTIAL AND COPYRIGHT PROPERTY OF THE HARWIN GROUP AND MUST NOT BE DISCLOSED, LOANED, COPIED OR USED FOR MANUFACTURING, TENDERING OR FOR ANY OTHER PURPOSE WITHOUT THEIR WRITTEN PERMISSION.

TOLERANCES
 X. = \pm 1mm
 X.X = \pm 0.50mm
 X.XX = \pm 0.20mm
 X.XXX = \pm 0.01mm
 ANGLES = \pm 5°
 UNLESS STATED

MATERIAL:
 BRASS CW614N M TO
 BS EN:12164 (CuZn39Pb3)
 FINISH: SEE ABOVE
 S/AREA: SEE ABOVE mm²

TITLE:
 TERMINAL PIN - \varnothing 1.75mm
 DRAWING NUMBER:
H218X-XX