

Click to
ORDER
samples

AMEL5-277NZ



The new AMEL5-277NZ is an AC/DC converter that offers much greater cost effectiveness due to increased production automation, leading to improved reliability and performance. Offering a wide industrial input voltage range of 85-305VAC and an output voltage range from 3.3-24V, this series will offer many benefits to your new system design.

This new series offers great operating temperatures, from -40°C to 70°C and isolation of 4000VAC for improved reliability and system safety. Furthermore, a high MTBF of 300,000h, output short circuit protection (OSCP), output over-current protection (OCP) and an output over-voltage protection (OVP) come standard with the series.

The AMEL5-277NZ is perfect for street lighting controls, grid power, instrumentation, industrial controls, telecom and civil applications.

Features

- Universal Input: 85 - 305VAC/100 - 430VDC
- Operating Temp: -40 °C to +70 °C
- High isolation voltage: 4000VAC
- Low ripple & noise, 100mV(p-p), max.
- Output short circuit, over-current, over-voltage protection
- Regulated Output

Summary

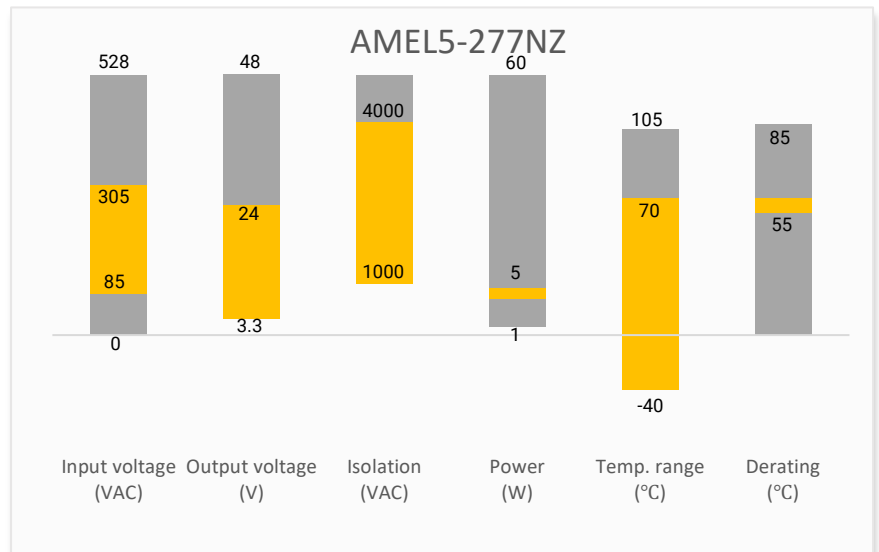

Training

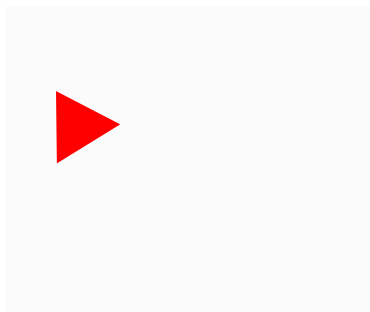

Product Training Video
(click to open)

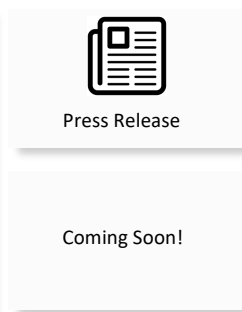

Application Notes

Applications



Power Grid



Industrial



Telecom



Instrumentation

Models & Specifications

Single Output							
Model	Input Voltage (VAC/Hz)	Input Voltage (VDC)	Max Output wattage (W)	Output Voltage (V)	Output Current max (mA)	Maximum capacitive load (μ F)	Efficiency @ 230VAC Typ. (%)
AMEL5-3.3S277NZ	85~305/47~63	100~430	4.2	3.3	1250	4000	70
AMEL5-5S277NZ	85~305/47~63	100~430	5	5	1000	4000	76
AMEL5-9S277NZ	85~305/47~63	100~430	5	9	550	1000	74
AMEL5-12S277NZ	85~305/47~63	100~430	5	12	420	820	77
AMEL5-15S277NZ	85~305/47~63	100~430	5	15	333	820	77
AMEL5-24S277NZ	85~305/47~63	100~430	5.5	24	230	470	80

Note: Use suffix "ST" for chassis and suffix "STD" for DIN-Rail mounting (ex. AMEL5-5S277NZ-ST is chassis mounting and AMEL5-5S277NZ-STD is DIN-Rail mounting version).

Input Specifications				
Parameters	Conditions	Typical	Maximum	Units
Input Current	115VAC		150	mA
	230VAC		100	
Inrush Current	115VAC	10		A
	230VAC	20		
External Input Fuse	1A/300V, slow-blow type			

Output Specifications				
Parameters	Conditions	Typical	Maximum	Units
Voltage accuracy	3.3V output model	± 3		%
	Others	± 2		
Line regulation	Full load	± 0.5		%
Load regulation	0-100% load	± 1		%
Ripple & Noise	20MHz bandwidth		100	mV p-p
Hold up time	115VAC	23		ms
	230VAC	100		

Isolation Specifications				
Parameters	Conditions	Typical	Maximum	Units
Tested I/O voltage	60 sec, Leakage current < 5mA	4000		VAC

General Specifications				
Parameters	Conditions	Typical	Maximum	Units
Over Current protection	Self-recovery	≥ 110		% of Iout
Over voltage protection	Zener diode clamp	3.3V / 5V Output	≤ 7.5	VDC
		9V Output	≤ 15	
		12V / 15V Output	≤ 20	
		24V Output	≤ 30	
Short circuit protection	Hiccup, Continuous, Self-recovery			
Switching Frequency		100		KHz
Operating temperature		-40 to +70		°C
Storage temperature		-40 to +85		°C
Power derating	-40°C ~ -25°C	2.67		% / °C
	55°C ~ 70°C	2.67		
	85 ~ 100 VAC	1		% / VAC
	277 ~ 305 VAC	0.54		
Soldering temperature	Wave-soldering	260 ± 5 °C ; 5 ~ 10 sec		
	Manual-welding	360 ± 10 °C ; 3 ~ 5 sec		
Temperature coefficient		±0.02		% / °C
Protection Class	Class II			
Cooling	Free air convection			
Storage Humidity			95	% RH
Case material	Heat resistant black Plastic (flammability to UL 94V-0)			
Weight	PCB mountable models	31		g
	With optional -ST mounting plate	52		
	With optional -STD mounting plate	70		
Dimensions (L x W x H)	PCB mountable models	2.00 x 1.00 x 0.60 inches (50.80 x 25.40 x 15.36mm)		
	With optional -ST mounting plate	2.99 x 1.24 x 0.95 inches (76.00 x 31.50 x 24.16mm)		
	With optional -STD mounting plate	2.99 x 1.24 x 1.13 inches (76.00 x 31.50 x 28.76mm)		
MTBF	> 300 000 hrs (MIL-HDBK -217F, t=+25°C)/Full Load			
NOTE: All specifications in this datasheet are measured at an ambient temperature of 25°C, humidity<75%, nominal input voltage and at rated output load unless otherwise specified.				

Safety Specifications			
Parameters			
Agency approvals	CE EN62368-1; cULus UL 62368-1		
Standards	Designed to meet IEC 62368 -1		
	EMC - Conducted and radiated emission	CISPR32 / EN55032, class B	
	Electrostatic Discharge Immunity	IEC 61000-4-2 Contact ±6KV, Air ±8KV, Criteria B	
	RF, Electromagnetic Field Immunity	IEC 61000-4-3 10V/m, Criteria A	
	Electrical Fast Transient/Burst Immunity	IEC 61000-4-4 ±2KV, Criteria B	
		IEC 61000-4-4 ±4KV, with EMC recommended circuit, Criteria B	
	Surge Immunity	IEC 61000-4-5 L-L ±1KV, Criteria B	
		IEC 61000-4-5 L-L ±2KV/L-G ±4KV, with EMC recommended circuit, Criteria B	
	CS, Conducted Disturbance Immunity	IEC 61000-4-6 10Vr.m.s, Criteria A	
Voltage dips, Short Interruptions Immunity	IEC 61000-4-11 0%, 70%, Criteria B		

Derating

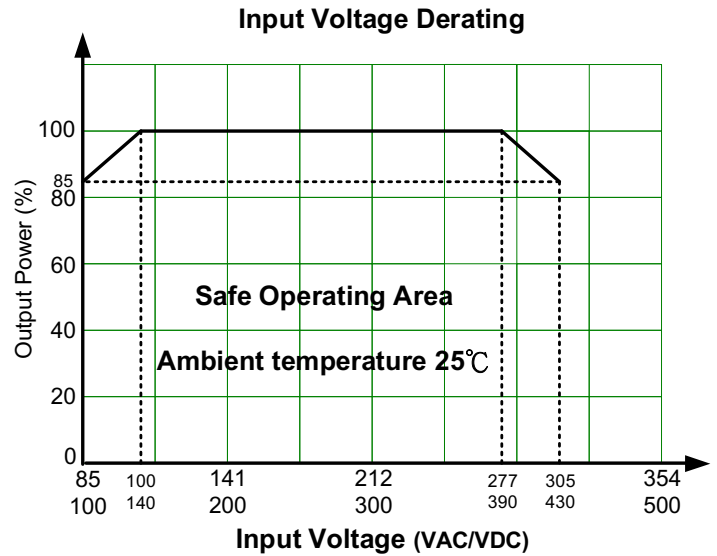
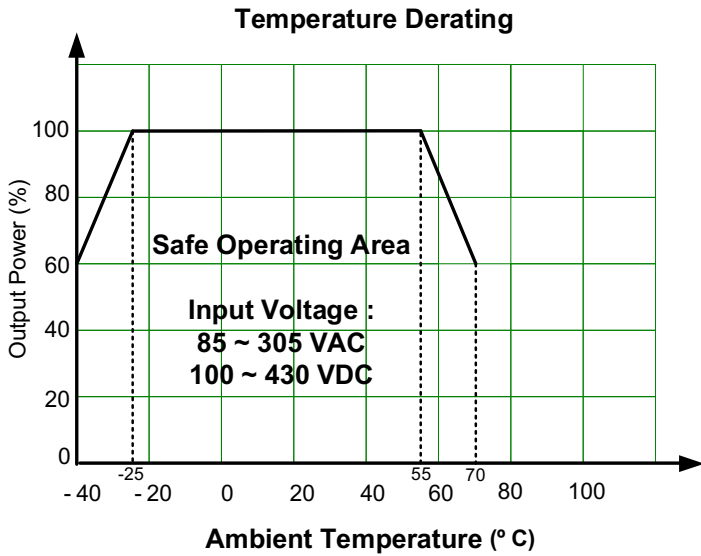

Typical Application Circuit

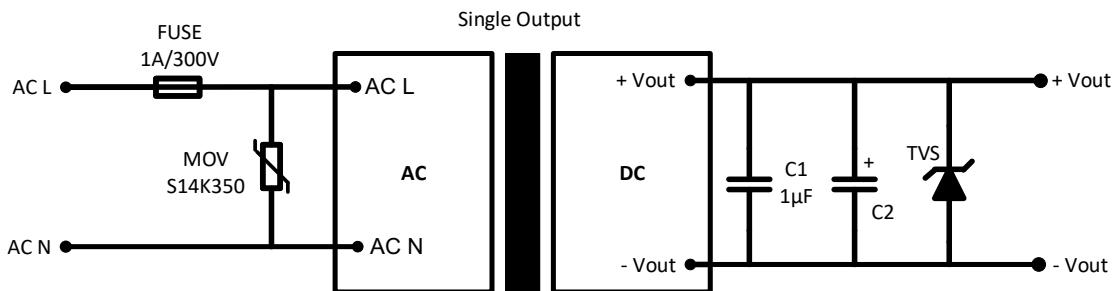

Model	C2(µF)	TVS
AMEL5-3.3S277NZ	220	SMBJ7A
AMEL5-5S277NZ	220	SMBJ7A
AMEL5-9S277NZ	100	SMBJ12A
AMEL5-12S277NZ	100	SMBJ20A
AMEL5-15S277NZ	100	SMBJ20A
AMEL5-24S277NZ	47	SMBJ30A

EMC Recommended Circuit

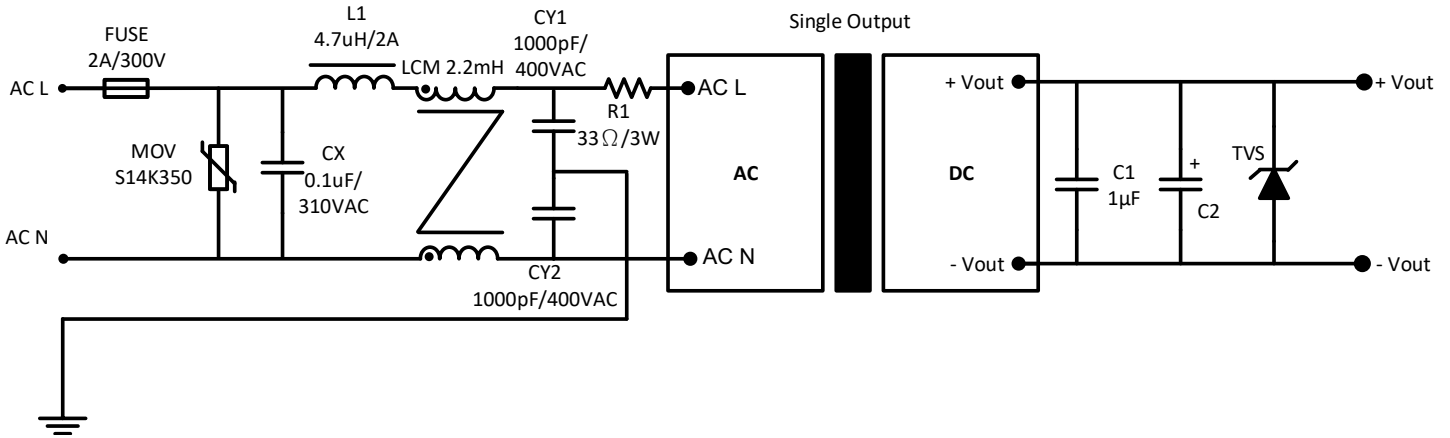

Dimensions

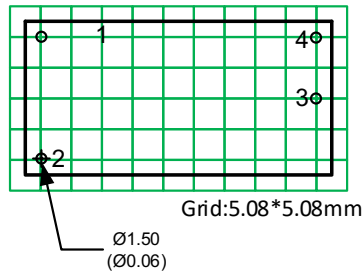
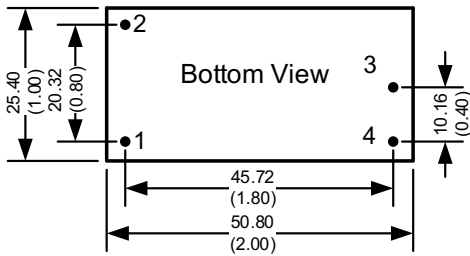

Pin Output Specifications	
Pin	Function
1	-V Input (N)
2	+V Input (L)
3	-V Output
4	+V Output

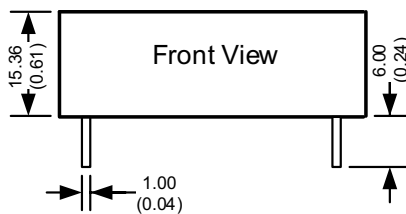

Dimensions mm (inch).
Pin diameter tolerance ± 0.1 (± 0.004)
General tolerance ± 0.5 (± 0.02)

Dimensions with ST Optional

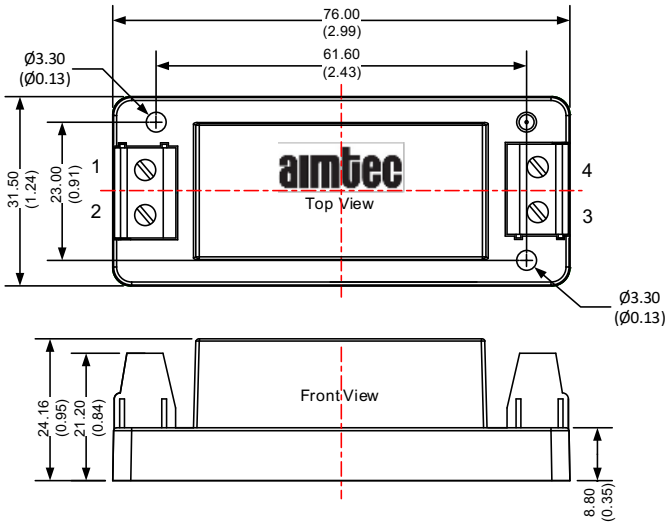

Dimensions mm (inch)
Wire range: 24-12 AWG
General tolerances ± 1.00 (± 0.04)

Pin Output Specifications	
Pin	Function
1	-V Input (N)
2	+V Input (L)
3	-V Output
4	+V Output

Dimensions with STD Optional

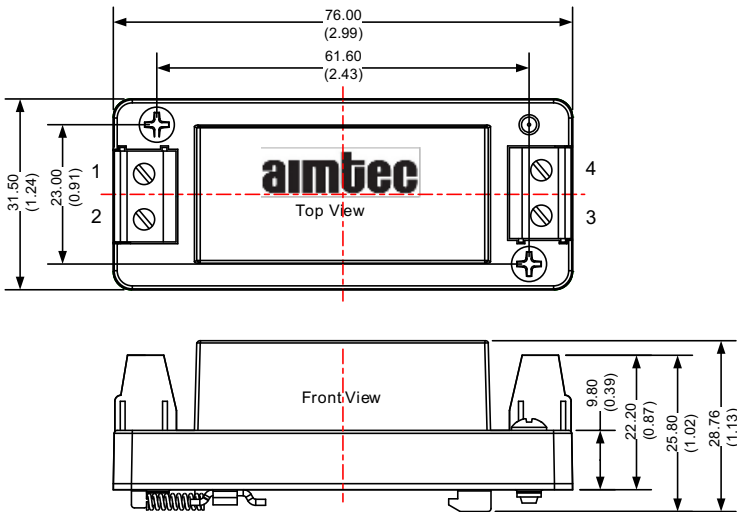

Dimensions mm (inch)
Wire range: 24-12 AWG
General tolerances: ± 1.00 (± 0.04)
Mounting rail: Rail needs to connect safety ground.

Pin Output Specifications	
Pin	Function
1	-V Input (N)
2	+V Input (L)
3	-V Output
4	+V Output

NOTE: 1. Datasheets are updated as needed and as such, specifications are subject to change without notice. Once printed or downloaded, datasheets are no longer controlled by Aimtec; refer to www.aimtec.com for the most current product specifications. 2. Product labels shown, including safety agency certifications on labels, may vary based on the date manufactured. 3. Mechanical drawings and specifications are for reference only. 4. All specifications are measured at an ambient temperature of 25°C, humidity < 75%, nominal input voltage and at rated output load unless otherwise specified. 5. Aimtec may not have conducted destructive testing or chemical analysis on all internal components and chemicals at the time of publishing this document. CAS numbers and other limited information are considered proprietary and may not be available for release. 6. This product is not designed for use in critical life support systems, equipment used in hazardous environments, nuclear control systems or other such applications which necessitate specific safety and regulatory standards other than the ones listed in this datasheet. 7. Warranty is in accordance with Aimtec's standard Terms of Sale available at www.aimtec.com.