



American Opto Plus LED Corp.

L199QEC-TR

1.0 x 0.5 x 0.5mm Red SMD LED

PACKAGE OUTLINES

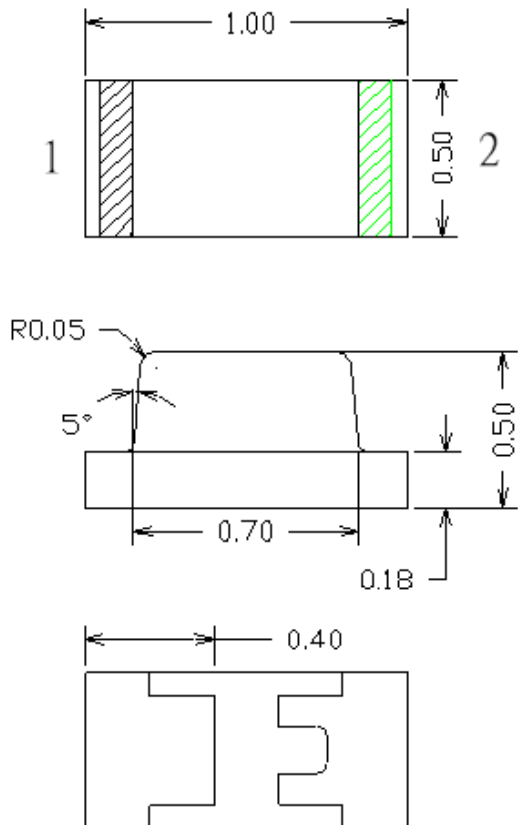

RECOMMEND PAD LAYOUT

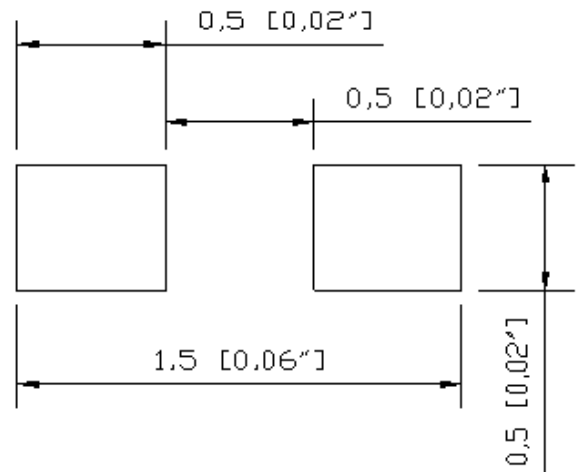

Item	Material
Resin(Mold)	Epoxy
Lens Color	Water Transparent
Dice	AlGaInP/GaAs
Emitted Color	Red

Notes:

1. All dimensions are in millimeters (inches)
2. Tolerances are ± 0.1 mm (0.004inch) unless otherwise noted



American Opto Plus LED Corp.

L199QEC-TR

1.0 x 0.5 x 0.5mm Red SMD LED

ABSOLUTE MAXIMUM RATINGS

(Ta=25°C)

	Symbol	Value	Unit
Forward Current	I _F	30	mA
Reverse Voltage	V _r	5	V
Power Dissipation	P _D	75	mW
Operating Temperature Range	T _{op}	-40~+80	°C
Storage Temperature Range	T _{stg}	-40~+85	°C
Peak Pulsing Current (1/8 duty f=1kHz)	I _{fp}	125	mA

OPTICAL-ELECTRICAL CHARACTERISTICS

(Ta=25°C)

	Symbol	Test Condition	Min	Typ	Max	Unit
Wavelength at peak emission	λ _p	I _f =20mA	--	640	--	nm
Spectral Half bandwidth	Δλ		--	18	--	nm
Dominant Wavelength	λ _d		625	630	635	nm
Forward Voltage	V _f		1.7	2.0	2.5	V
Luminous Intensity	I _v		50	100	160	mcd
Viewing Angle at 50% I _v	2Θ1/2	I _f =10mA	--	140	--	deg
Reverse Current	I _r	V _r =5V	--	--	10	μA



American Opto Plus LED Corp.

L199QEC-TR

1.0 x 0.5 x 0.5mm Red SMD LED

Forward Voltage Rank

(IF=20mA)

Rank	Min.	Max.	Unit
□	1.7	2.5	V

Luminous Intensity Rank

(IF=20mA)

Rank	Min.	Max.	Unit
G	50	63	mcd
H	63	80	
I	80	100	
J	100	125	
K	125	160	

Dominant Wavelength Rank

(IF=20mA)

Rank	Min.	Max.	Unit
u	625	630	nm
v	630	635	

Group Name on Label (Example DATA: □Jv 20)

DATA: □Jv 20	Vf(V)	Iv (mcd)	λd (nm)	Test Condition
□→ J→ v →20	1.7 ~ 2.5	100~125	630~635	IF= 20mA

Notes:

1. Tolerance of luminous intensity (Iv) is ±15%
2. Tolerance of Dominant wavelength is ± 1.5nm
3. This specification is preliminary



American Opto Plus LED Corp.

L199QEC-TR

1.0 x 0.5 x 0.5mm Red SMD LED

OPTICAL CHARACTERISTIC CURVES

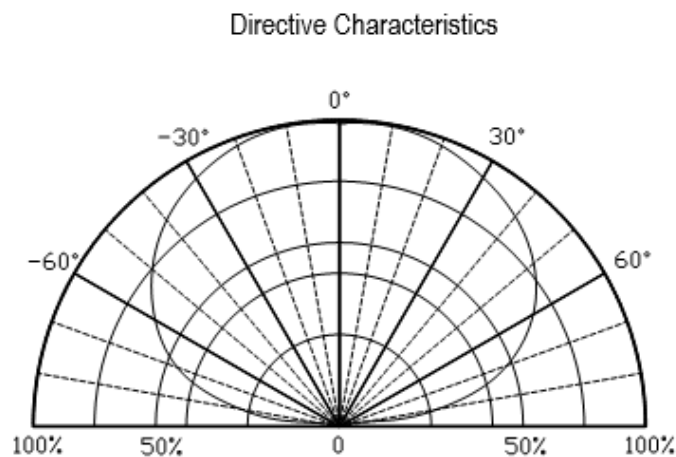
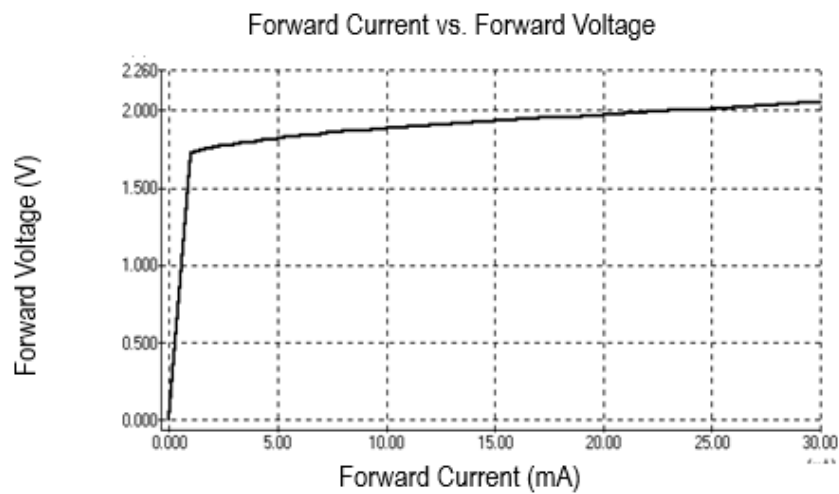
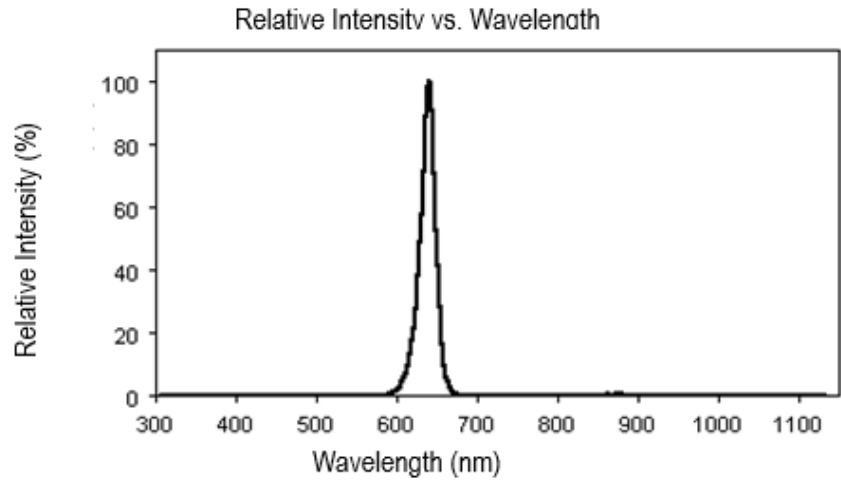



American Opto Plus LED Corp.

L199QEC-TR

1.0 x 0.5 x 0.5mm Red SMD LED

REFLOW PROFILE

- Reflow Temp/Time

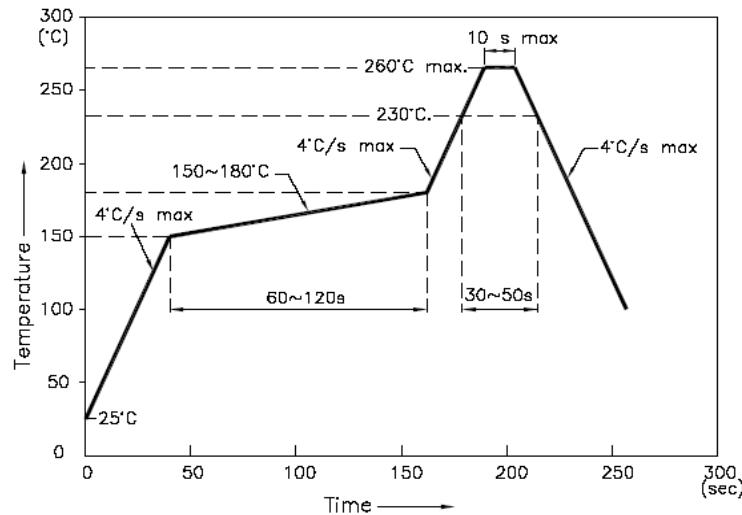

Notes:

1. We recommend the reflow temperature 245°C ($\pm 5^\circ\text{C}$). the maximum soldering temperature should be limited to 260°C.
2. Don't cause stress to the epoxy resin while it is exposed to high temperature.
3. Number of reflow process shall be 2 times or less.

Soldering iron

- Basic spec is $\leq 5\text{sec}$ when 260°C. If temperature is higher, time should be shorter ($+10^\circ\text{C} \rightarrow -1\text{sec}$). Power dissipation of iron should be smaller than 20W, and temperatures should be controllable. Surface temperature of the device should be under 230°C.

Rework

1. Customer must finish rework within 5 seconds under 260°C
2. Head of iron cannot touch copper foil
3. Twin-head type is preferred

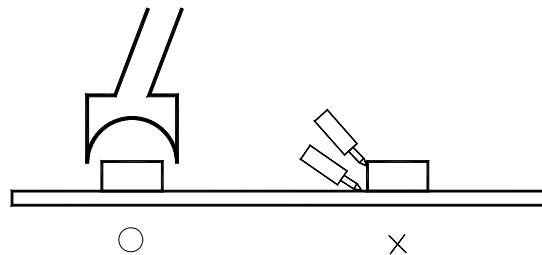

- Avoid rubbing or scraping the resin by any object during high temperature, for example, reflow solder etc.



American Opto Plus LED Corp.

L199QEC-TR

1.0 x 0.5 x 0.5mm Red SMD LED

TEST CIRCUIT AND HANDLING PRECAUTIONS

- **Test circuit**

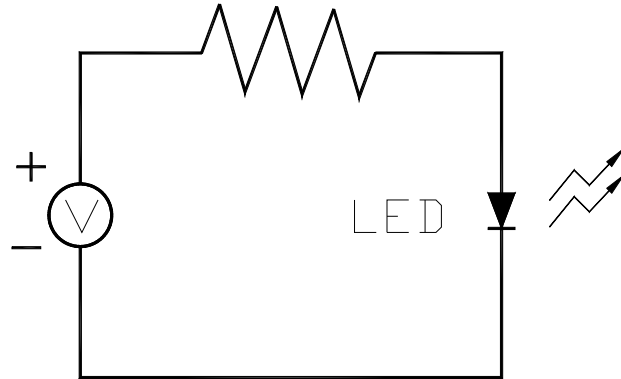

- **Handling precautions**

1. Over-current-proof
Customer must apply resistors for protection; otherwise slight voltage shift will cause big current change (Burn out will happen).
2. Shelf life in sealed bag: 12 month at 5°C ~30°C and < 60% RH
3. After package is opened:
 - 3.1. It is recommended to baking before the first use:
Baking condition:
 - a. 60±5°C x (24~48hrs) and < 5%RH, taped reel type
 - b. 110±5°C x (8~16hr), bulk type
 - 3.2 The products should be used within a week and to be stored at ≤20% R.H. with zip-lock sealed:
 - a. Baking is required before soldering when the pack is unsealed after 24hrs
 - b. Baking condition as 3.1 baking condition



American Opto Plus LED Corp.

L199QEC-TR

1.0 x 0.5 x 0.5mm Red SMD LED

TEST AND RESULTS OF RELIABILITY

Type	Test Item	Test Conditions	Note	Number of Damaged
Environmental Sequence	Temperature Cycle	-20°C 30min ↑↓ 80°C 30min	100 cycle	0/22
	Thermal Shock	-20°C 15min ↑↓ 80°C 15min	100 cycle	0/22
	High Humidity Heat Cycle	30°C ↔ 65°C 90%RH 24hrs/1cycle	10 cycle	0/22
	High Temperature Storage	T _a =80°C	1000 hrs	0/22
	Humidity Heat Storage	T _a =60°C RH=90%	1000 hrs	0/22
	Low Temperature Storage	T _a =-30°C	1000 hrs	0/22
Operation Sequence	Life Test	T _a =25°C I _F =20mA	1000 hrs	0/22
	High Humidity Heat Life Test	60°C RH=90% I _F =10mA	500 hrs	0/22
	Low Temperature Life Test	T _a =-20°C I _F =20mA	1000 hrs	0/22



American Opto Plus LED Corp.

L199QEC-TR

1.0 x 0.5 x 0.5mm Red SMD LED

PACKAGING SPECIFICATION

- Feeding Direction

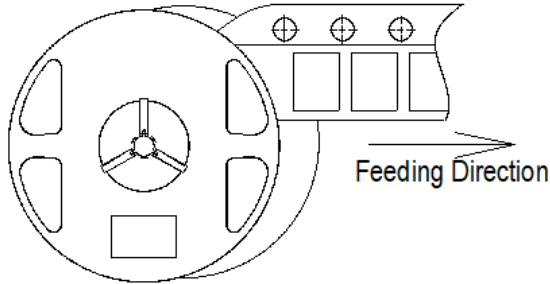

- Dimensions of Reel (Unit: mm)

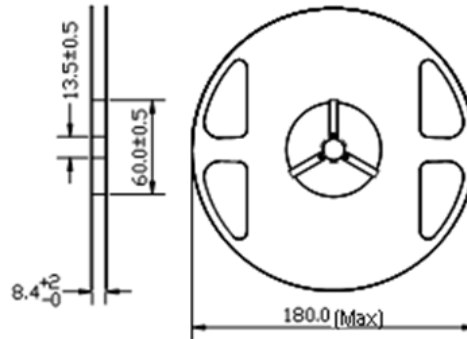

- Dimensions of Tape

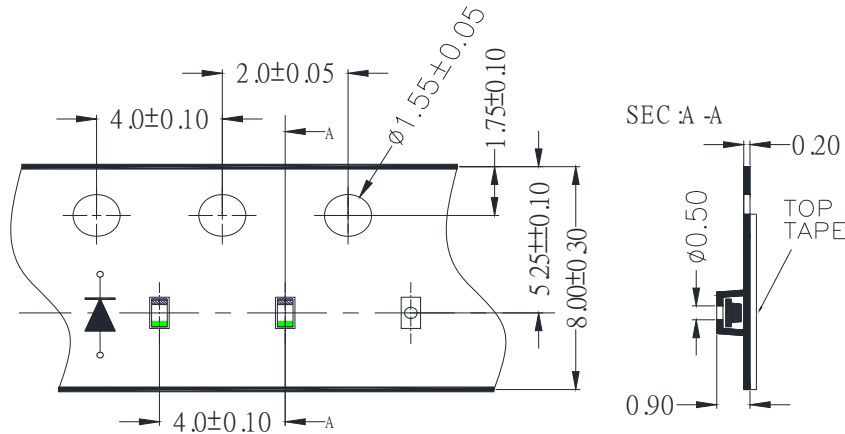

- Arrangement of Tape

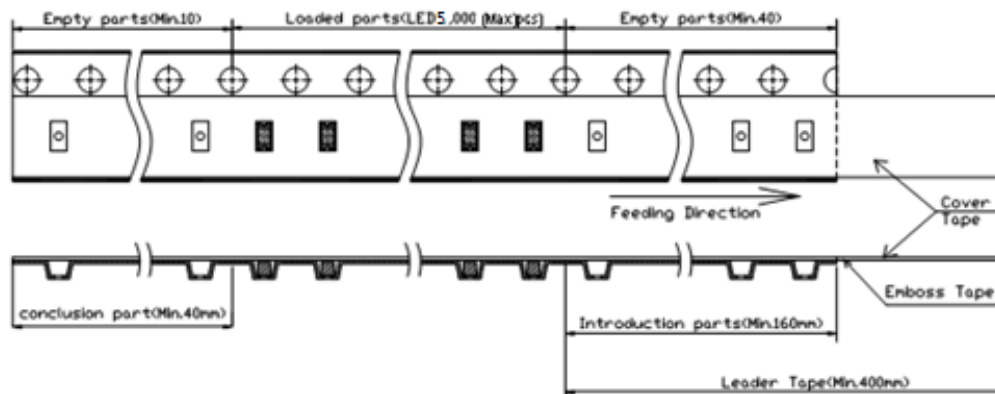

Notes:

1. Empty component pockets are sealed with top cover tape
2. The maximum number of missing lamps is two
3. The cathode is oriented towards the tape sprocket hole
4. 5,000 (max) pcs/Reel



American Opto Plus LED Corp.

L199QEC-TR

1.0 x 0.5 x 0.5mm Red SMD LED

PACKAGING SPECIFICATION

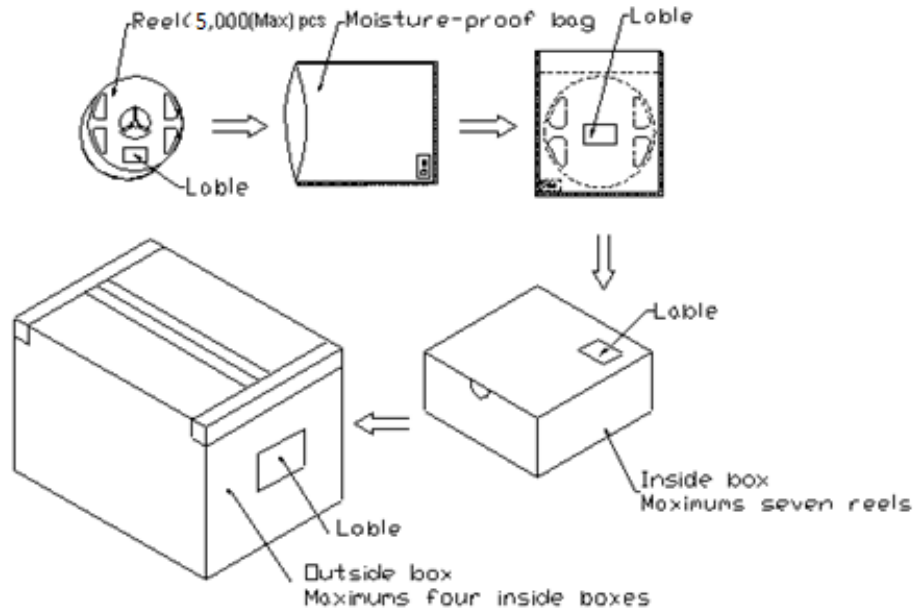

NOTES:

Reeled products [numbers of products are 5,000(Max)pcs] packed in a seal off moisture-proof bag along with a desiccant one by one, Seven moisture-proof bag of maximums [total maximum number of products are 35,000(Max)pcs] packed in an inside box (size: about 238mm x about 194mm x about 102mm) and four inside boxes of maximums are put in the outside box (size: about 410mm x about 254mm x about 229mm) Together with buffer material, and it is packed. (Part No., Lot No., quantity should appear on the label on the moisture-proof bag, part No. And quantity should appear on the label on the cardboard box.) The number of the loading steps of outside box (cardboard box) has it to three steps.