

ACDC Fan

This fan works while internally converting AC power into DC power, providing the superior performance of a DC fan with the flexibility of AC input.

Model Numbering System

Not every combination of the following codes or characters is available. Contact us for an available combination.

9AD	09	01	H	1	2	
Type name	Frame size	Voltage	Speed code	Frame thickness	Sensor specifications	Frame form
Type name	9AD					
Frame size (mm)	09	12				
	92×92	120×120				
Voltage (V)	01					
	100 to 240					
Speed code	H M etc.					
Frame thickness (mm)	1					
	38					
Sensor specifications	2		H			
	Without a sensor		With a low-speed sensor			
Frame form	Nil			1		
	Plastic frame: Ribbed frame			Plastic frame: Ribless frame		

Centrifugal Fan

9ADT	S	11	P	0	G	001
Type name	Impeller size	Voltage	PWM control function	Thickness	Speed code	Individual customer's spec

Bracket-mounted Splash Proof Centrifugal Fan

9ADB1T	S	11	P	0	G	001
Type name	Impeller size	Voltage	PWM control function	Thickness	Speed code	Individual customer's spec

Type name	9ADT 9ADW1T 9ADB1T 9ADB1W1T					
Impeller size (mm)	S					
	ø225					
Voltage (V)	11		23			
	115		230			
Thickness (mm)	0					
	69 _{min.}					
Speed code	G H etc.					

How to Read Specifications (ACDC fan)

The following is a sample. See respective product pages for detailed information.

Model no.	Rated voltage [V]	Operating voltage range [V]	Frequency [Hz]	Rated current [A]	Rated input [W]	Rated speed [min ⁻¹]	Max. airflow [m ³ /min] [CFM]	Max. static pressure [Pa] [inchH ₂ O]	SPL [dB (A)]	Operating temperature [°C]	Expected life [h]
9AD0901H12	100 to 240	90 to 264	50/60	0.08	4.5	3850	1.5 53.0	90 0.36	40	-20 to +75	60000/60°C (90000/40°C)
9AD0901M12				0.06	3.0	3100	1.18 41.7	56 0.22	33		

- Rated voltage This is the necessary voltage to drive the fan. Single-phase 100 to 240 VAC are also available.
- Operating voltage range The voltage range over which fan operation is guaranteed.
- Frequency This is a frequency of alternating current (AC). The frequencies of 50 Hz and 60 Hz are existing in Japan.
- Rated current The current when the fan is operating at rated voltage (at free air).
- Rated input The power value when the fan is operating at rated voltage (at free air).
- Rated speed The speed when the fan is operating at rated voltage (at free air).
- Max. airflow The maximum airflow that the fan can generate during rated operation (measured with our double chamber measuring device).
Airflow is the volume of air generated by the fan per unit of time.
- Max. static pressure The maximum static pressure value that the fan can produce during rated operation (measured with our double chamber measuring device).
Static pressure indicates a fan's ability to move air against resistance due to the internal structure of the device to which the fan is installed.
- SPL SPL stands for Sound Pressure Level. The noise level during the fan's rated operation.
Please refer to the technical material section for the measurement method.
- Operating temperature The temperature range over which fan operation is guaranteed (Non- condensing).
- Expected life Service life hours that 90% of bearings will survive without failing when continuously operated at the rated voltage and 60°C temperature. Expected life at 40°C is for reference only.
For more information, please refer to the technical material section.



92x92x38 mm

San Ace 92AD 9AD type

General Specifications

- Material Frame: Plastic (Flammability: UL 94V-0), Impeller: Plastic (Flammability: UL 94V-0)
- Expected life See the table below. (L10 life: 90% survival rate for continuous operation in free air at 60°C, rated voltage)
Expected life at 40°C is for reference only.
- Motor structure Brushless DC motor
- Motor protection function Locked rotor burnout protection
For details, please refer to p. 599.
- Dielectric strength 50/60 Hz, 1500 VAC, for 1 minute (between input terminal and frame, and between sensor output and frame)
- Insulation resistance 10 MΩ or more with a 500 VDC megger (between lead wire conductors and frame)
- Sound pressure level (SPL) At 1 m away from the air inlet
- Storage temperature -30 to +75°C (Non-condensing)
- Mass 250 g

Do not solder wires directly to AC input terminals.

Specifications

The models listed below **have ribs and no sensors**. For models without ribs, append "1" to the end of model numbers.

Model no.	Rated voltage [V]	Operating voltage range [V]	Frequency [Hz]	Rated current [A]	Rated input [W]	Rated speed [min ⁻¹]	Max. airflow [m ³ /min] [CFM]	Max. static pressure [Pa] [inchH ₂ O]	SPL [dB (A)]	Operating temperature [°C]	Expected life [h]
➤ 9AD0901H12	100 to 240	90 to 264	50/60	0.08	4.5	3850	1.5 53.0	90 0.36	40	-20 to +75	60000/60°C (90000/40°C)
➤ 9AD0901M12				0.06	3.0	3100	1.18 41.7	56 0.22	33		

The models listed below **have ribs and low-speed sensors**. For models without ribs, append "1" to the end of model numbers.

Model no.	Rated voltage [V]	Operating voltage range [V]	Frequency [Hz]	Rated current [A]	Rated input [W]	Rated speed [min ⁻¹]	Max. airflow [m ³ /min] [CFM]	Max. static pressure [Pa] [inchH ₂ O]	SPL [dB (A)]	Operating temperature [°C]	Expected life [h]
➤ 9AD0901H1H	100 to 240	90 to 264	50/60	0.08	4.5	3850	1.5 53.0	90 0.36	40	-20 to +75	60000/60°C (90000/40°C)
➤ 9AD0901M1H				0.06	3.0	3100	1.18 41.7	56 0.22	33		

Note 1: Sensor and control options are available for selection. Refer to the table on p. 641.

Note 2: The ➤ mark indicates Short LeadTime Service applicable models. See p. 654 for details.

Set Models

Fan, finger guard, plug cord, screws, etc. can be purchased in one package. For details, please refer to p. 655.

Order no.	Set items					
	Fan	Voltage	Low-speed sensor	Plug cord	Finger guards	Mounting screws
ST1-9AD0901H12	9AD0901H12	100 to 240 V		489-1635-L10	109-099E	M4x55 mm (4 screws)
ST1-9AD0901M12	9AD0901M12			489-1635-L10	109-099E	
ST1-9AD0901H1H	9AD0901H1H		○	489-1635-L10	109-099E	
ST1-9AD0901M1H	9AD0901M1H		○	489-1635-L10	109-099E	

Airflow - Static Pressure Characteristics

9AD0901H12, 9AD0901H1H

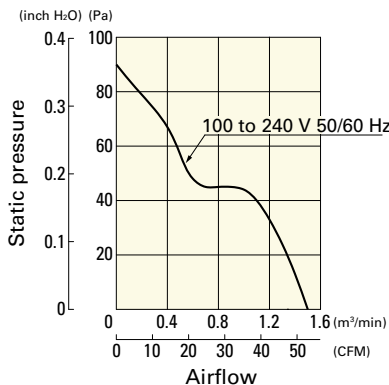

9AD0901M12, 9AD0901M1H

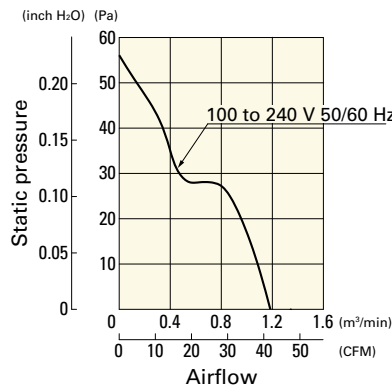

Dimensions (unit: mm) (With ribs)

without Sensor

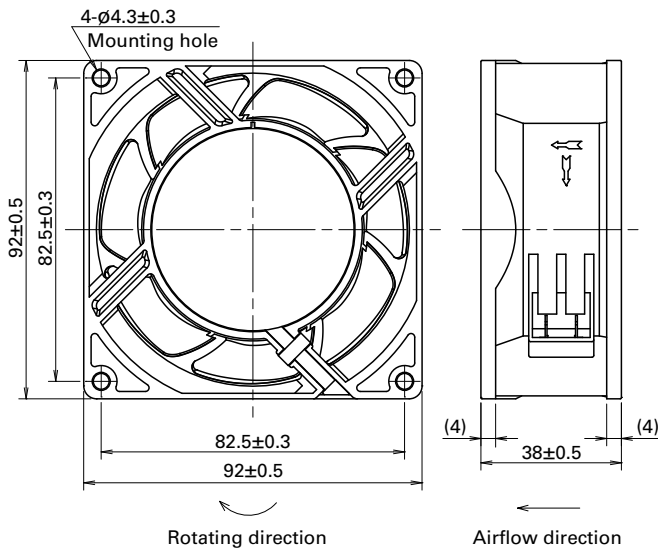

with Low-speed sensor

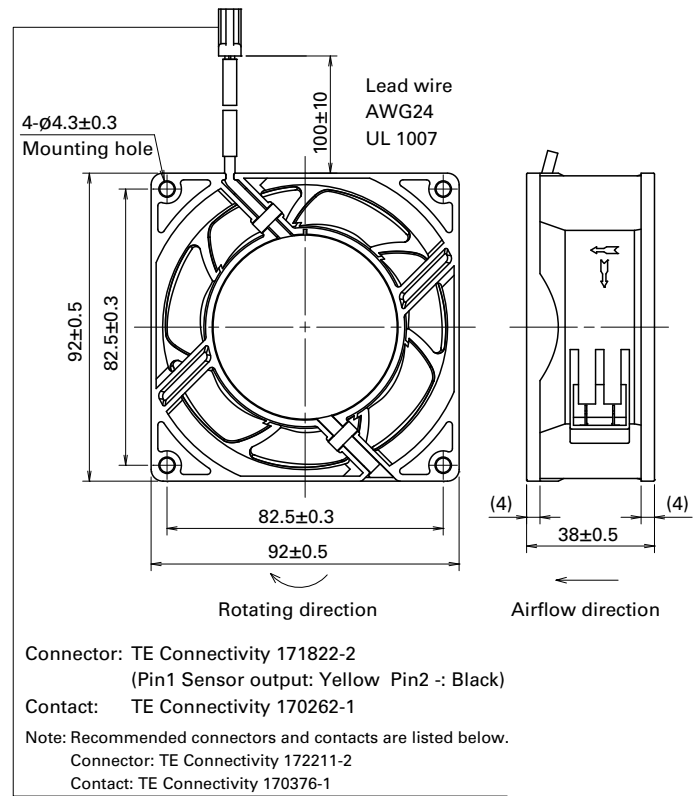

Reference Dimensions of Mounting Holes and Vent Opening (unit: mm)

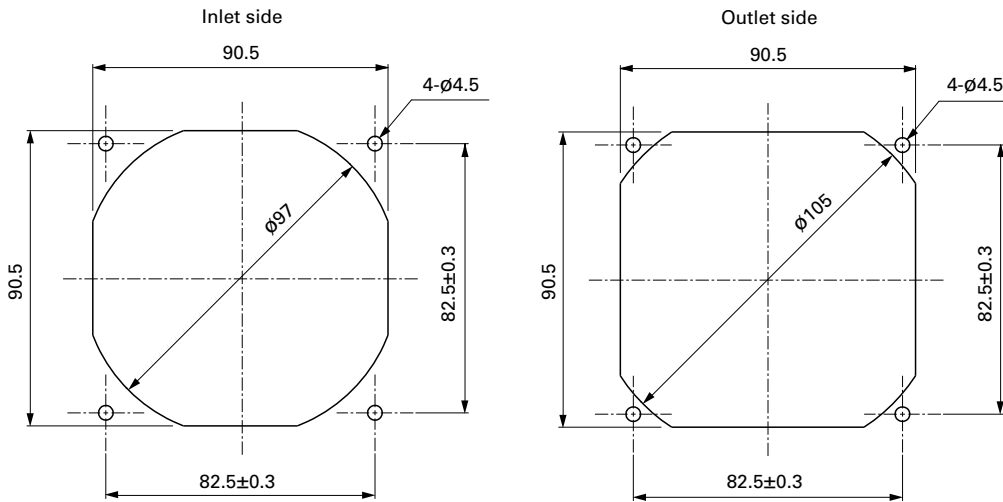

Wiring Diagram

without Sensor

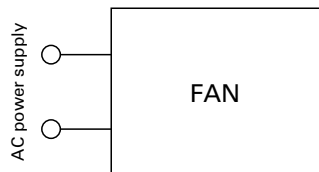

with Low-speed sensor

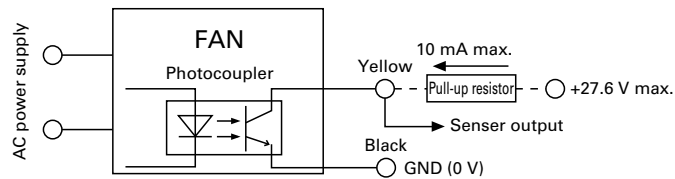

Specifications for Low-speed Sensors

Typical standard model: 9AD0901H1H

Output circuit: Open collector

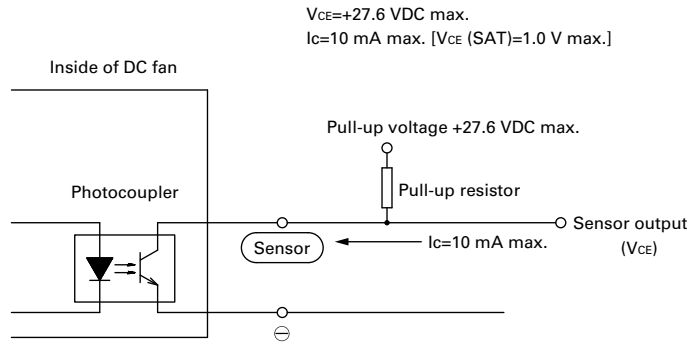

Sensor scheme

Example 1: when steady running

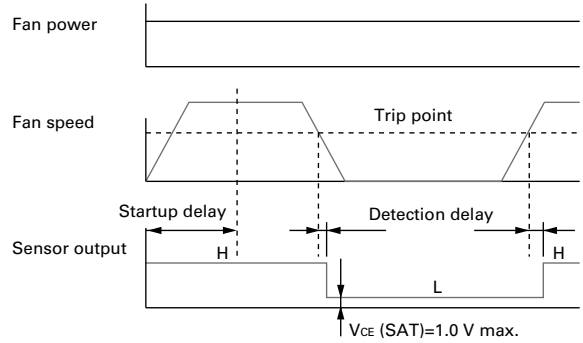

Example 2: when the rotor is locked when the fan motor is turned on and released after the start-up delay time.

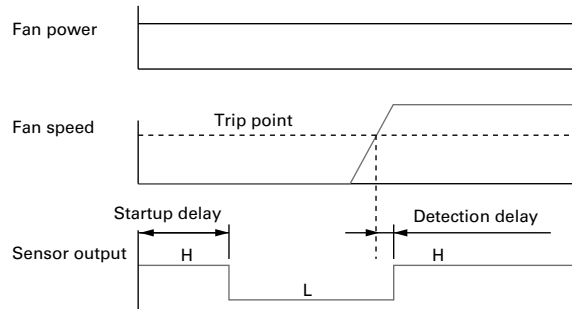

9AD0901H1H

Startup delay: 18±3 s
Detection delay: 3 s max.
Trip point: 1700 min⁻¹

9AD0901M1H

Startup delay: 36±3 s
Detection delay: 3 s max.
Trip point: 850 min⁻¹

Options

Finger guards page: p. 584

Model no.: 109-099C, 109-099E, 109-099H

Resin finger guards page: p. 591

Model no.: 109-1001G

Resin filter kits page: p. 592

Model no.: 109-1001F13 (13PPI), 109-1001F20 (20PPI),
109-1001F30 (30PPI), 109-1001F40 (40PPI)

Plug cord page: p. 595

Model no.: 489-1635-L10, 489-1635-L21

Wiring harness for sensor page: p. 595

Model no.: 489-1636

Features of the San Ace 92AD 9AD type ACDC Fan

Low power consumption **Long life** **Wide voltage range** (Compared with our existing AC fan with equal size.)

With AC input, the same level of energy saving and long life as a DC fan can be achieved. The maintenance effort can be reduced too.

Power consumption comparison

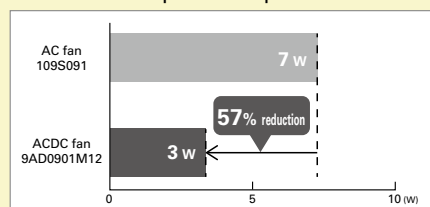

Expected life comparison

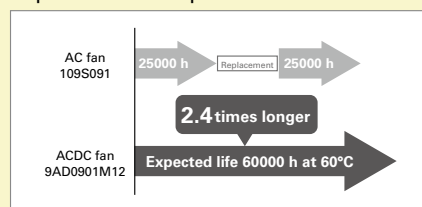



120x120x38 mm

San Ace 120AD 9AD_{type}

General Specifications

- Material Frame: Plastic (Flammability: UL 94V-0), Impeller: Plastic (Flammability: UL 94V-1)
- Expected life See the table below. (L10 life: 90% survival rate for continuous operation in free air at 60°C, rated voltage)
Expected life at 40°C is for reference only.
- Motor structure Brushless DC motor
- Motor protection function Locked rotor burnout protection
For details, please refer to p. 599.
- Dielectric strength 50/60 Hz, 1500 VAC, for 1 minute (between input terminal and frame, and between sensor output and frame)
- Insulation resistance 10 MΩ or more with a 500 VDC megger (between lead wire conductors and frame)
- Sound pressure level (SPL) At 1 m away from the air inlet
- Storage temperature -30 to +75°C (Non-condensing)
- Mass 290 g

Do not solder wires directly to AC input terminals.

Specifications

The models listed below **have ribs and no sensors**. For models without ribs, append "1" to the end of model numbers.

Model no.	Rated voltage [V]	Operating voltage range [V]	Frequency [Hz]	Rated current [A]	Rated input [W]	Rated speed [min ⁻¹]	Max. airflow [m ³ /min] [CFM]	Max. static pressure [Pa] [inchH ₂ O]	SPL [dB (A)]	Operating temperature [°C]	Expected life [h]
☞ 9AD1201H12	100 to 240	90 to 264	50/60	0.08	4.4	3250	3.0 106	84 0.34	42	-20 to +75	60000/60°C (90000/40°C)

The models listed below **have ribs and low-speed sensors**. For models without ribs, append "1" to the end of model numbers.

Model no.	Rated voltage [V]	Operating voltage range [V]	Frequency [Hz]	Rated current [A]	Rated input [W]	Rated speed [min ⁻¹]	Max. airflow [m ³ /min] [CFM]	Max. static pressure [Pa] [inchH ₂ O]	SPL [dB (A)]	Operating temperature [°C]	Expected life [h]
☞ 9AD1201H1H	100 to 240	90 to 264	50/60	0.08	4.4	3250	3.0 106	84 0.34	42	-20 to +75	60000/60°C (90000/40°C)

Note 1: Sensor and control options are available for selection. Refer to the table on p. 641.

Note 2: The ☞ mark indicates Short LeadTime Service applicable models. See p. 654 for details.

Set Models

Fan, finger guard, plug cord, screws, etc. can be purchased in one package. For details, please refer to p. 655.

Order no.	Set items					
	Fan	Voltage	Low-speed sensor	Plug cord	Finger guards	Mounting screws
ST1-9AD1201H12	9AD1201H12	100 to 240 V		489-1635-L10	109-019E	M4x55 mm (4 screws)
ST1-9AD1201H1H	9AD1201H1H		○	489-1635-L10	109-019E	

Airflow - Static Pressure Characteristics

9AD1201H12, 9AD1201H1H

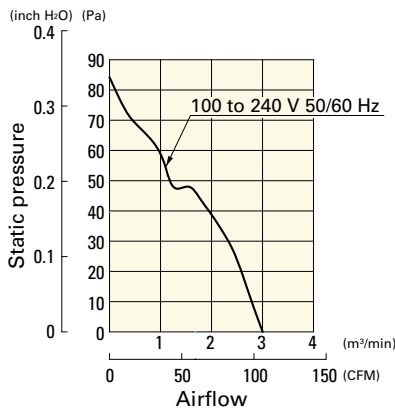

Dimensions (unit: mm) (With ribs)

without Sensor

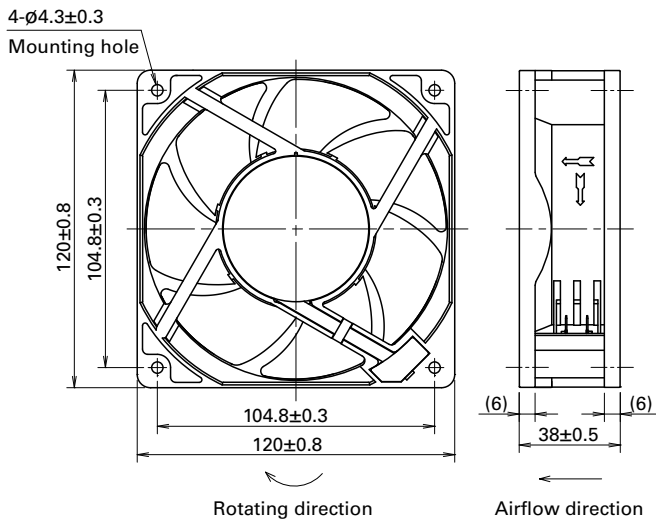

with Low-speed sensor

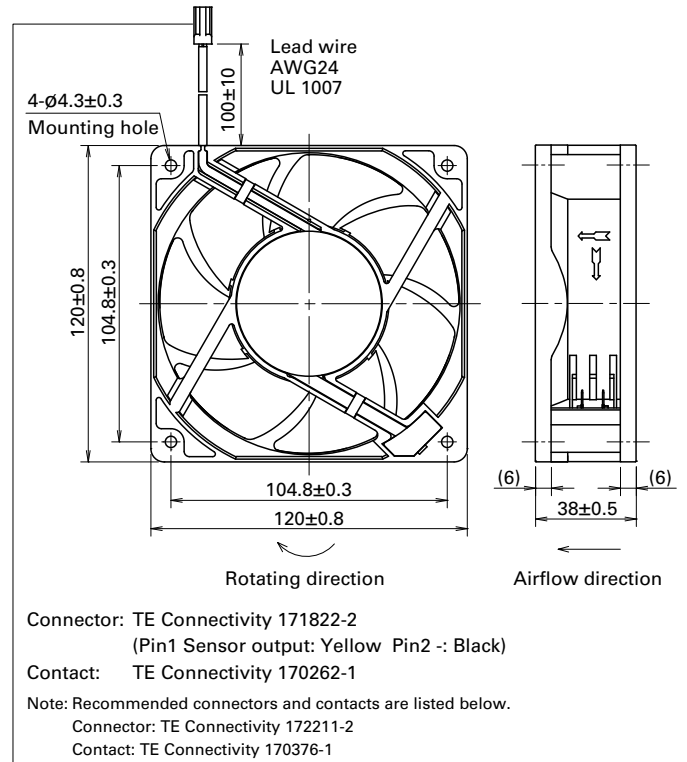

Reference Dimensions of Mounting Holes and Vent Opening (unit: mm)

ACDC Fan 120 mm sq.

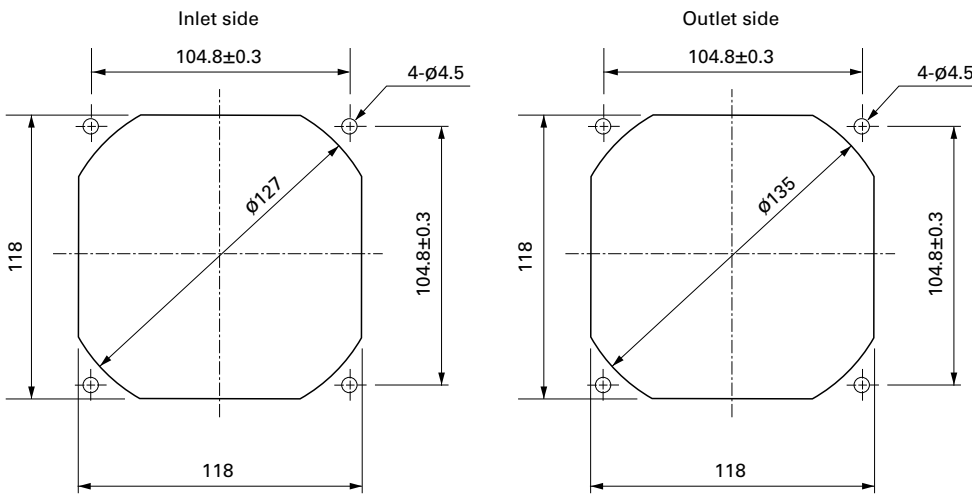

Wiring Diagram

without Sensor

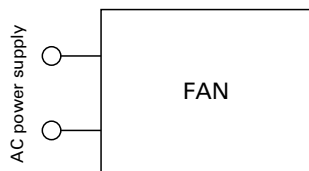

with Low-speed sensor

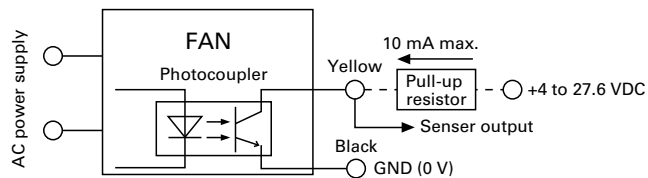

Specifications for Low-speed Sensors

Model No.: 9AD1201H1H

Output circuit: Open collector

$V_{CE} = +27.6$ VDC max.
 $I_C = 10$ mA max. [$V_{CE(SAT)} = 1.0$ V max.]

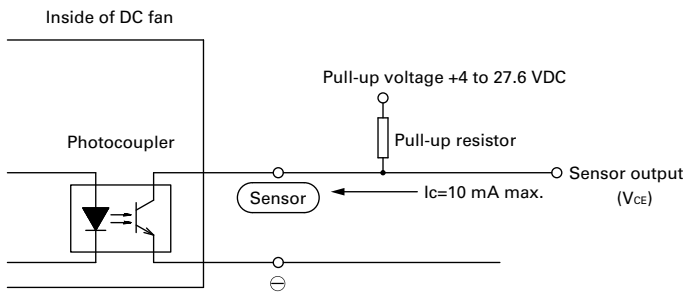

Sensor scheme

Example 1: when steady running

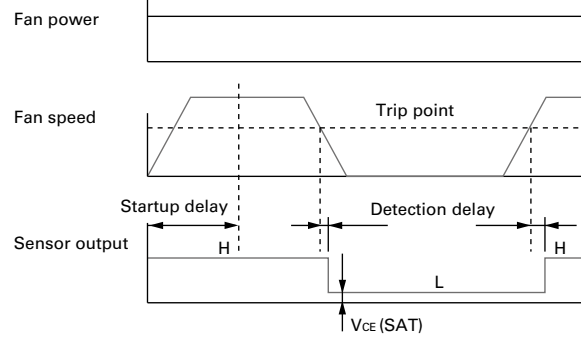

Example 2: when the rotor is locked when the fan motor is turned on and released after the start-up delay time.

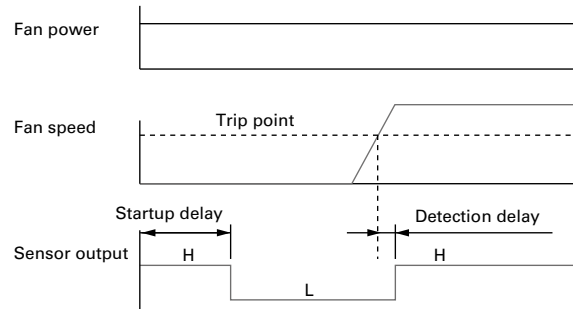

Startup delay: 18 ± 3 s
 Detection delay: 3 s max.
 Trip point: 1700 min^{-1}

Options

Finger guards page: p. 585

Model no.: 109-019C, 109-019H, 109-019E, 109-019K

Resin finger guards page: p. 591

Model no.: 109-1000G

Resin filter kits page: p. 592

Model no.: 109-1000F13 (13PPI), 109-1000F20 (20PPI),
 109-1000F30 (30PPI), 109-1000F40 (40PPI)

Plug cord page: p. 595

Model no.: 489-1635-L10, 489-1635-L21

Wiring harness for sensor page: p. 595

Model no.: 489-1636

Features of the San Ace 120AD 9AD type ACDC Fan

Low power consumption **Long life** **Wide voltage range** (Compared with our existing AC fan with equal size.)

With AC input, the same level of energy saving and long life as a DC fan can be achieved.
 The maintenance effort can be reduced too.

Power consumption comparison

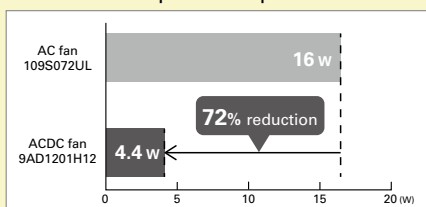

Expected life comparison

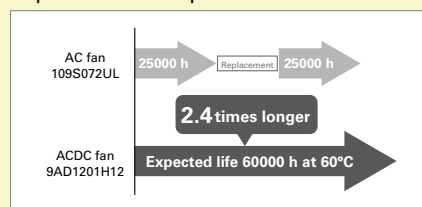



∅225x99 mm

San Ace 225AD 9ADTS type

General Specifications

- Material Motor case: Aluminum (Black coating), Impeller: Plastic (Flammability: UL 94V-0)
- Expected life See the table below. (L10 life: 90% survival rate for continuous operation in free air at 60°C, rated voltage) Expected life at 40°C is for reference only.
- Motor protection function Locked rotor burnout protection For details, please refer to p. 599.
- Dielectric strength 50/60 Hz, 1500 VAC, for 1 minute (between lead wire conductors and motor case)
- Insulation resistance 10 MΩ or more with a 500 VDC megger (between lead wire conductors and motor case)
- Sound pressure level (SPL) At 1 m away from the air inlet
- Storage temperature -30 to +70°C (Non-condensing)
- Lead wire

AC power input	L: Orange	N: Gray	Ground	Yellow / Green
+10 VDC output	Red	Black	Sensor	Yellow
			Control	Brown
- Mass 1800 g

Specifications When the optional inlet nozzle (109-1134) is mounted.

The models listed below **have pulse sensors with PWM control function.**

Model no.	Rated voltage [V]	Operating voltage range [V]	PWM duty cycle [%]	Rated current [A]	Rated input [W]	Rated speed [min ⁻¹]	Max. airflow [m ³ /min] [CFM]	Max. static pressure [Pa] [inchH ₂ O]	SPL [dB (A)]	Operating temperature [°C]	Expected life [h]
9ADTS11P0G001	115	90 to 132	100	2.23	155	3200	23.0 812	815 3.27	74	-20 to +60	40000/60°C (70000/40°C)
			20	0.3	10	1000	7.1 252	80 0.32	50		
9ADTS11P0F001			100	1.11	70	2450	17.6 621	480 1.93	68		
			20	0.3	10	1000	7.1 252	80 0.32	50		
9ADTS23P0G001	230	180 to 264	100	1.17	155	3200	23.0 812	815 3.27	74		
			20	0.2	10	1000	7.1 252	80 0.32	50		
9ADTS23P0F001			100	0.64	70	2450	17.6 621	480 1.93	68		
			20	0.2	10	1000	7.1 252	80 0.32	50		

* PWM input frequency is 1 kHz; models without specifications at 0% PWM duty cycle have zero fan speed at 0%.

• AC power frequency: 50/60 Hz

Airflow - Static Pressure Characteristics / PWM Duty - Speed Characteristics Example

9ADTS11P0G001 With pulse sensor with PWM control function

PWM duty cycle

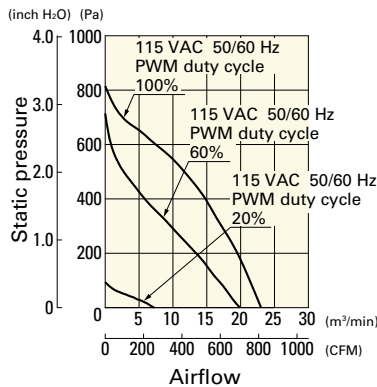

PWM duty - Speed characteristics example

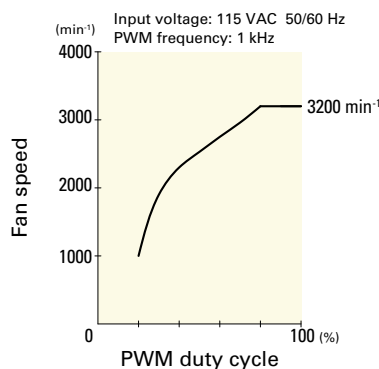

Dimensions (unit: mm)

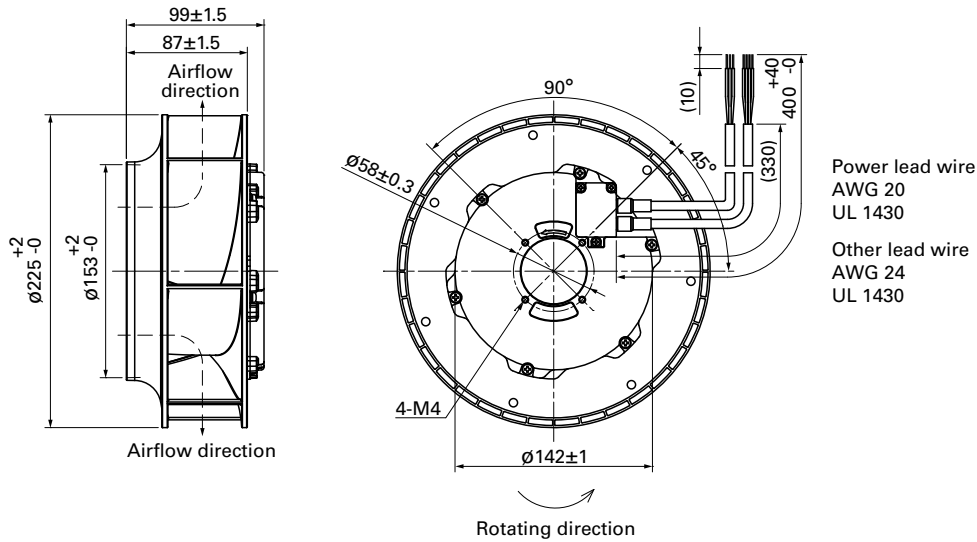

Reference Dimensions of Mounting Holes and Vent Opening (unit: mm)

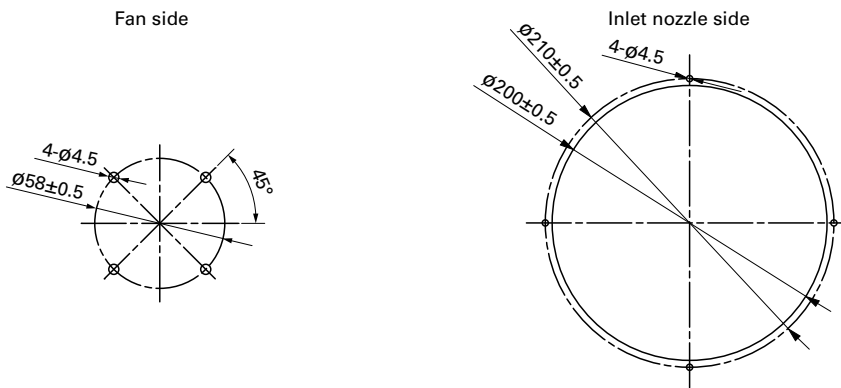

Reference Diagram for Mounting

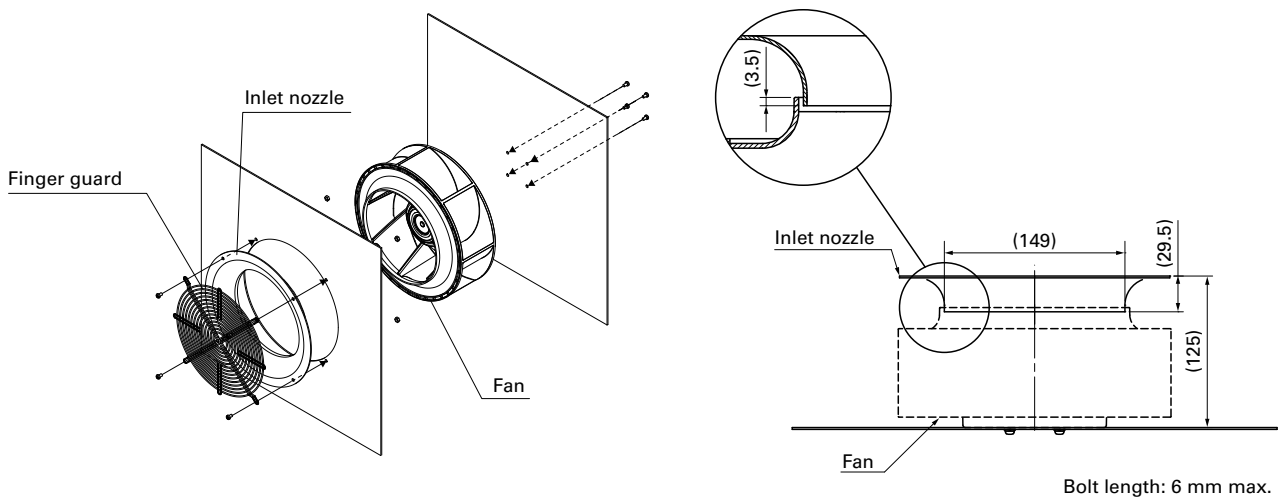

Options

Finger guards

page: p. 587

Model no.: 109-1137, 109-1137H

Inlet nozzle

page: p. 589

Model no.: 109-1134, 109-1134H



Ø **225x99** mm

San Ace 225AD 9ADW1TS type   

General Specifications

- Material Motor case: Aluminum (Black coating), Impeller: Plastic (Flammability: UL 94V-0)
- Expected life See the table below. (L10 life: 90% survival rate for continuous operation in indoor free air at 60°C, rated voltage) Expected life at 40°C is for reference only.
- Motor protection function Locked rotor burnout protection For details, please refer to p. 599.
- Dielectric strength 50/60 Hz, 1500 VAC, for 1 minute (between lead wire conductors and motor case)
- Insulation resistance 10 MΩ or more with a 500 VDC megger (between lead wire conductors and motor case)
- Sound pressure level (SPL) At 1 m away from the air inlet
- Storage temperature -30 to +70°C (Non-condensing)
- Lead wire

AC power input	L: Orange	N: Gray	Ground	Yellow / Green
+10 VDC output	Red	Black	Sensor	Yellow
			Control	Brown
- Mass 1900 g
- Ingress protection IP56

Specifications When the optional inlet nozzle (109-1134H) is mounted.

The models listed below **have pulse sensors with PWM control function.**

Model no.	Rated voltage [V]	Operating voltage range [V]	PWM duty cycle [%]	Rated current [A]	Rated input [W]	Rated speed [min ⁻¹]	Max. airflow [m ³ /min] [CFM]	Max. static pressure [Pa] [inchH ₂ O]	SPL [dB (A)]	Operating temperature [°C]	Expected life [h]
9ADW1TS11P0H001	115	90 to 132	100	2.06	140	3100	22.3 787	760 3.05	73	-20 to +60	40000/60°C (70000/40°C)
			20	0.3	11	1000	7.1 252	80 0.32	50		
9ADW1TS11P0M001			100	1.08	61	2350	16.9 597	440 1.77	67		
			20	0.3	11	1000	7.1 252	80 0.32	50		
9ADW1TS23P0H001	230	180 to 264	100	1.06	140	3100	22.3 787	760 3.05	73		
			20	0.2	11	1000	7.1 252	80 0.32	50		
9ADW1TS23P0M001			100	0.57	61	2350	16.9 597	440 1.77	67		
			20	0.2	11	1000	7.1 252	80 0.32	50		

* PWM input frequency is 1 kHz; models without specifications at 0% PWM duty cycle have zero fan speed at 0%.

· AC power frequency: 50/60 Hz

Airflow - Static Pressure Characteristics / PWM Duty - Speed Characteristics Example

9ADW1TS11P0H001 With pulse sensor with PWM control function

PWM duty cycle

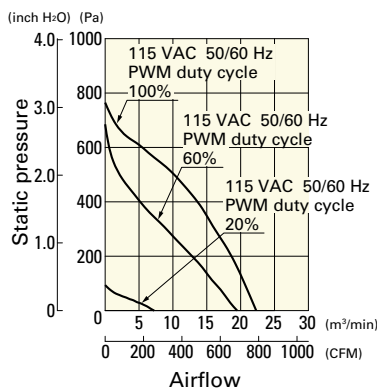

PWM duty - Speed characteristics example

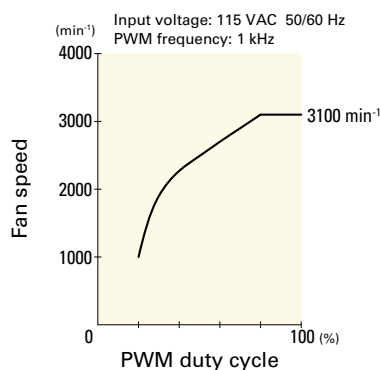

ACDC Fan Ø225 mm

Airflow - Static Pressure Characteristics / PWM Duty - Speed Characteristics Example

9ADW1TS11P0M001 With pulse sensor with PWM control function

PWM duty cycle

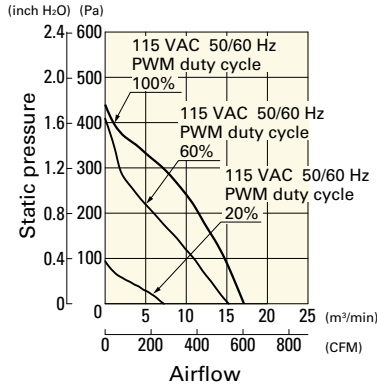

PWM duty - Speed characteristics example

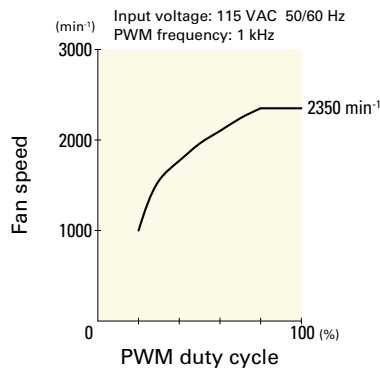

9ADW1TS23P0H001 With pulse sensor with PWM control function

PWM duty cycle

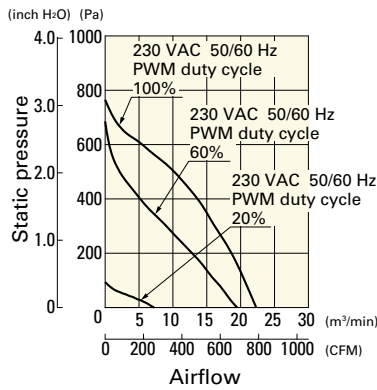

PWM duty - Speed characteristics example

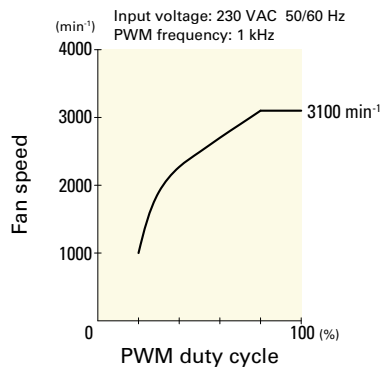

9ADW1TS23P0M001 With pulse sensor with PWM control function

PWM duty cycle

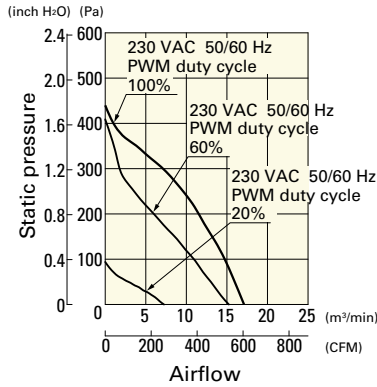

PWM duty - Speed characteristics example

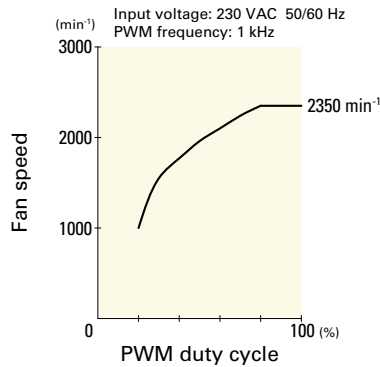

ACDC Fan φ225 mm

Wiring Diagram

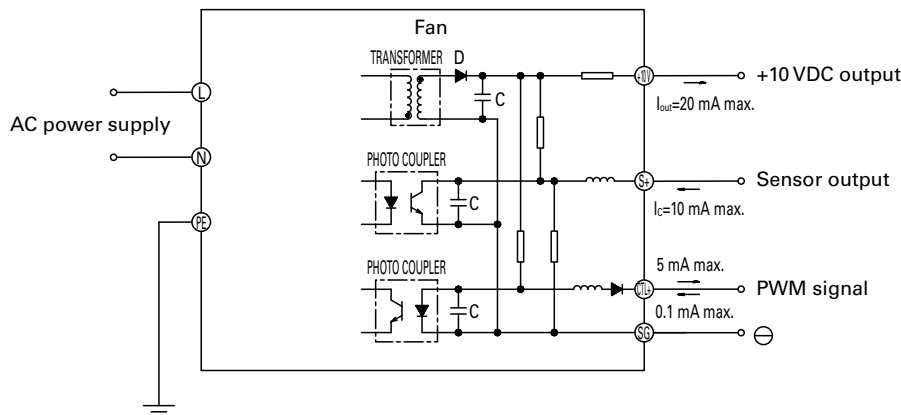

Dimensions (unit: mm)

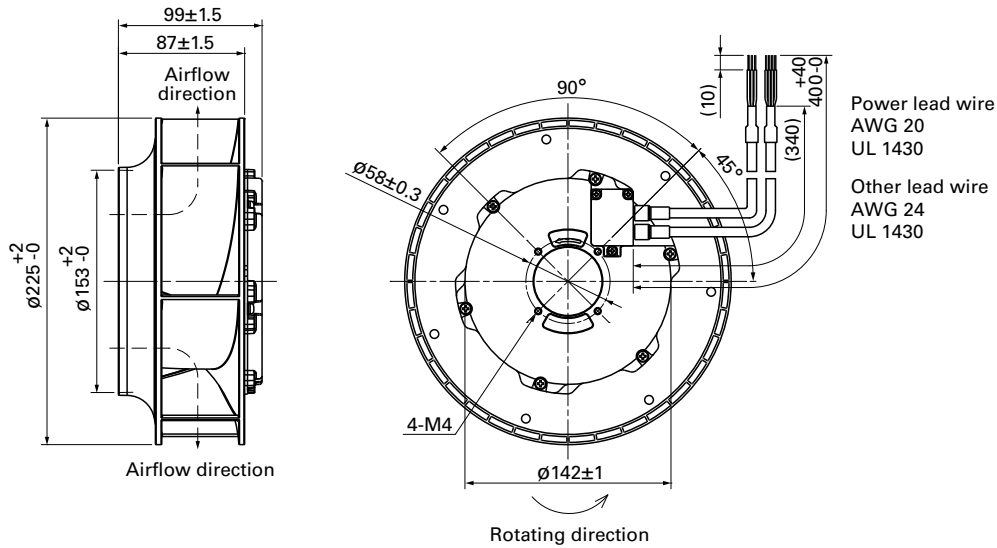

Reference Dimensions of Mounting Holes and Vent Opening (unit: mm)

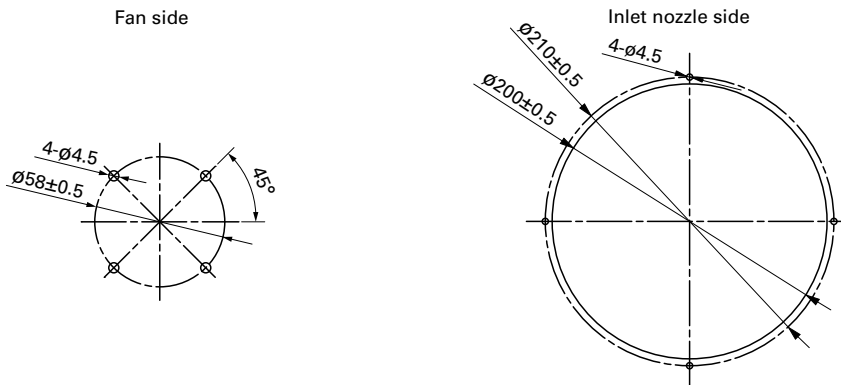

Reference Diagram for Mounting

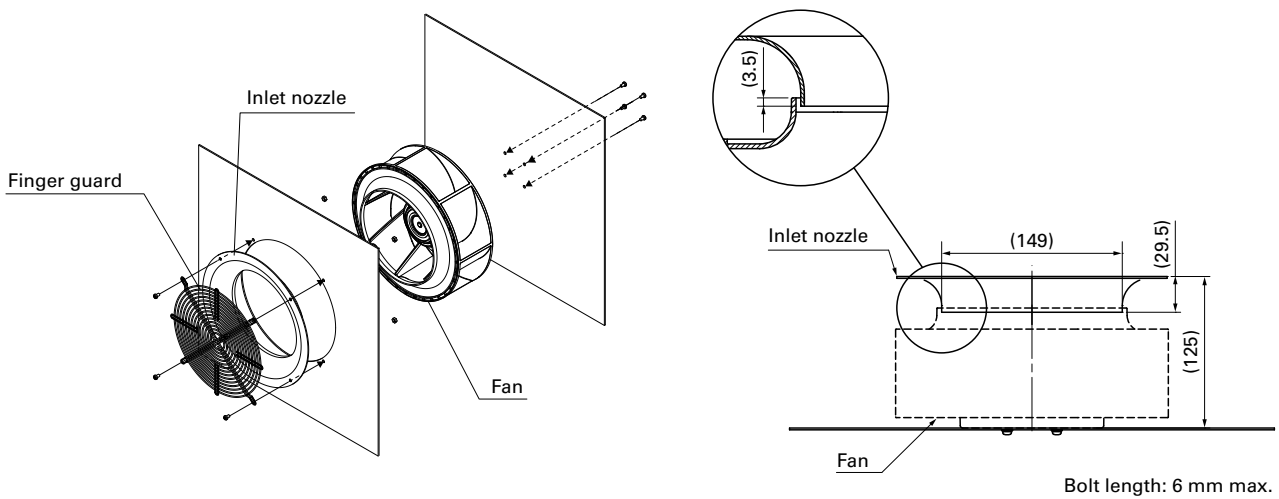

Options

Finger guards

page: p. 587

Model no.: 109-1137, 109-1137H

Inlet nozzle

page: p. 589

Model no.: 109-1134, 109-1134H

Airflow - Static Pressure Characteristics / PWM Duty - Speed Characteristics Example

9ADB1TS11P0F001 With pulse sensor with PWM control function

PWM duty cycle

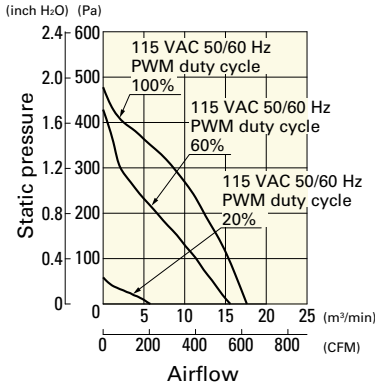

PWM duty - Speed characteristics example

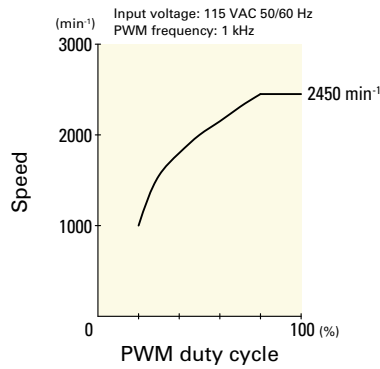

9ADB1TS23P0G001 With pulse sensor with PWM control function

PWM duty cycle

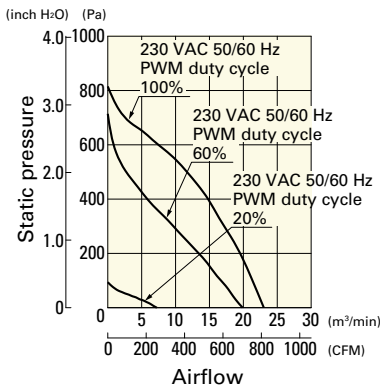

PWM duty - Speed characteristics example

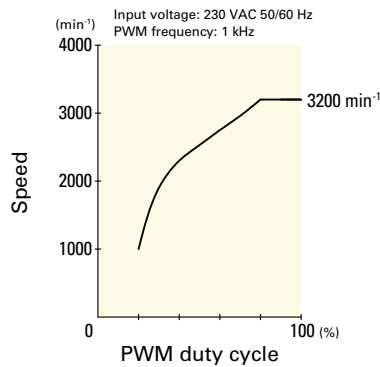

9ADB1TS23P0F001 With pulse sensor with PWM control function

PWM duty cycle

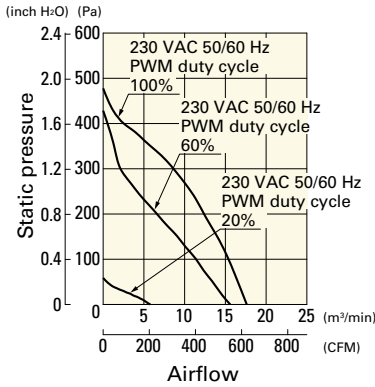

PWM duty - Speed characteristics example

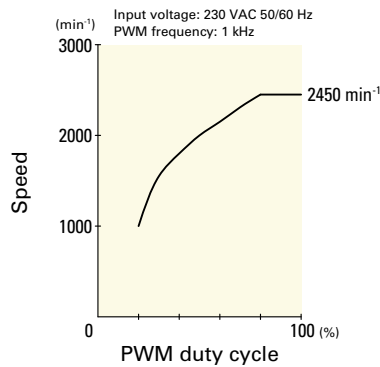

Wiring Diagram

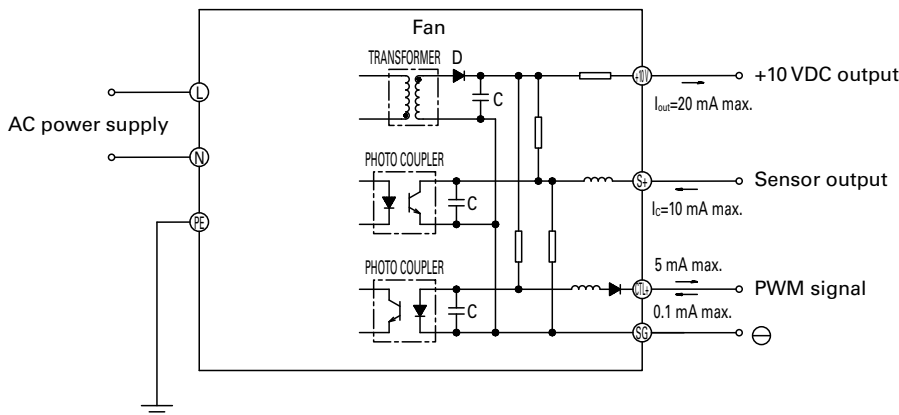

Airflow - Static Pressure Characteristics / PWM Duty - Speed Characteristics Example

9ADB1W1TS11P0M001 With pulse sensor with PWM control function

PWM duty cycle

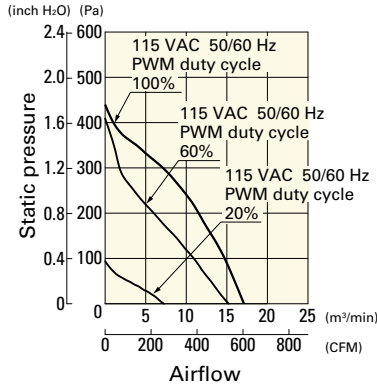

PWM duty - Speed characteristics example

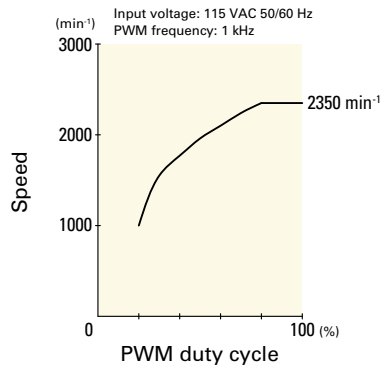

9ADB1W1TS23P0H001 With pulse sensor with PWM control function

PWM duty cycle

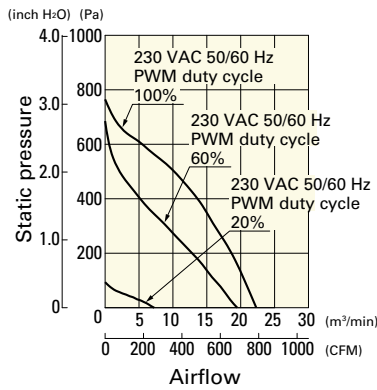

PWM duty - Speed characteristics example

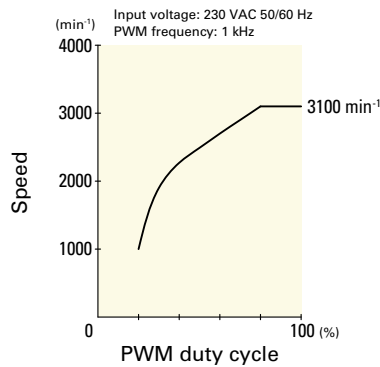

9ADB1W1TS23P0M001 With pulse sensor with PWM control function

PWM duty cycle

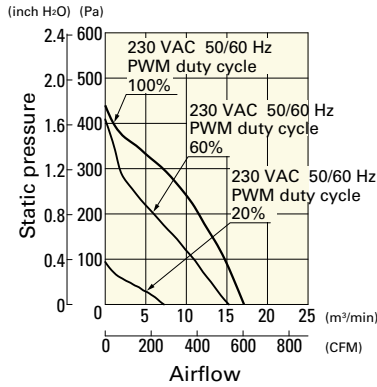

PWM duty - Speed characteristics example

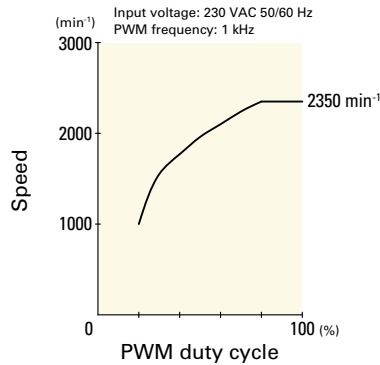

ACDC Fan 270 mm sq.

Wiring Diagram

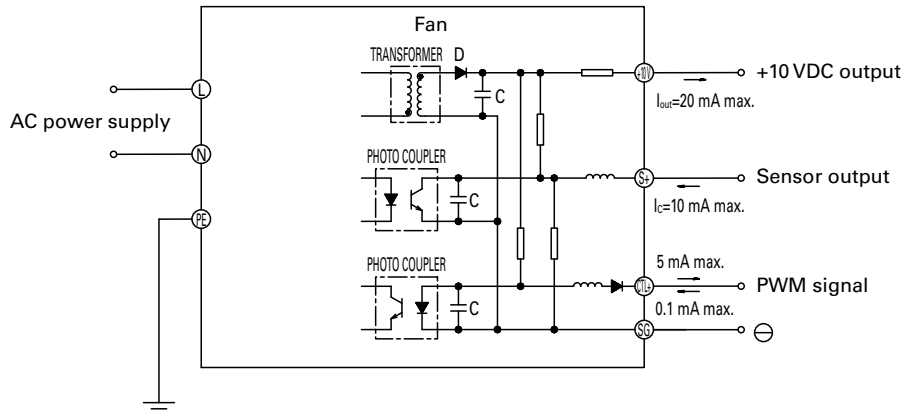

Dimensions (unit: mm)

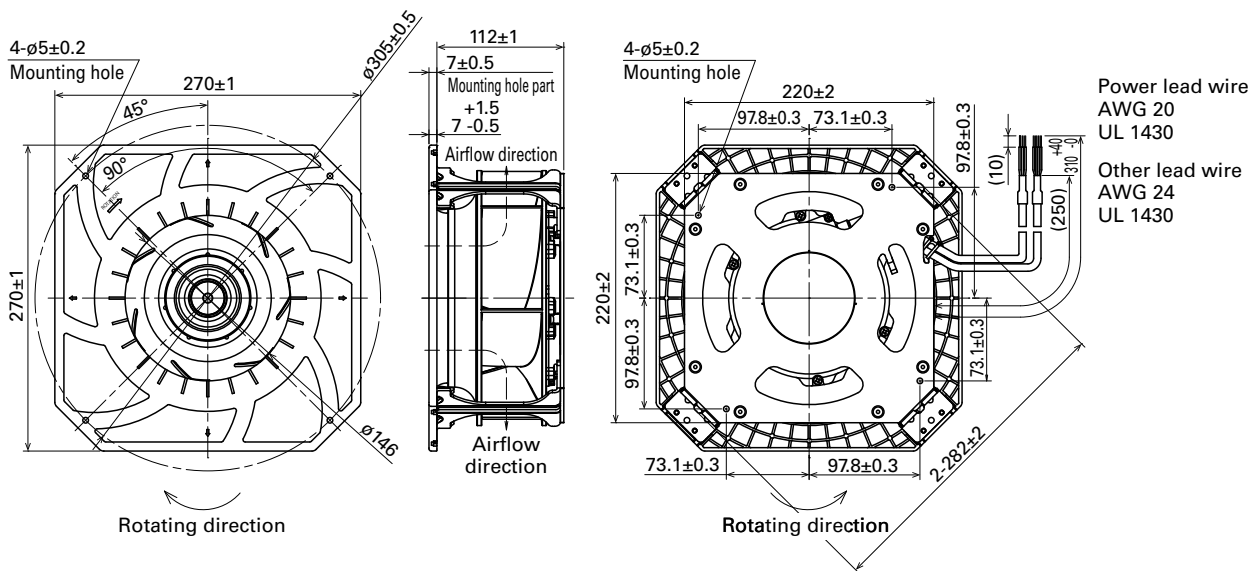

Reference Dimensions of Mounting Holes and Vent Opening (unit: mm)

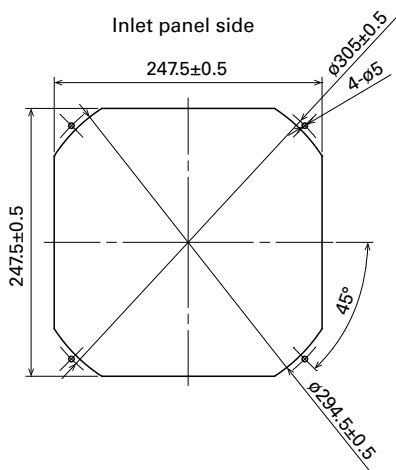

Reference Diagram for Mounting

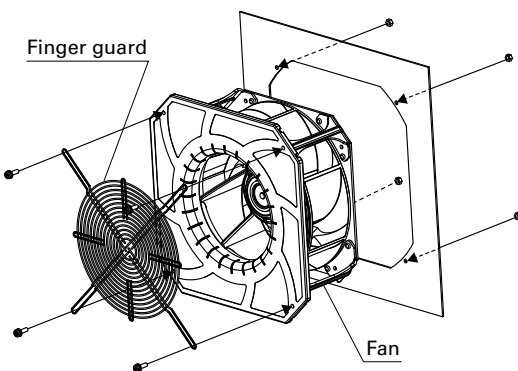

Options

Finger guards

page: p. 588

Model no.: 109-1146, 109-1146H

AC Fan

The cooling fan operates at 100 to 230 VAC.

■ How to Read Specifications (AC fan) The following is a sample. See respective product pages for detailed information.

Model no.	Rated voltage [V]	Frequency [Hz]	Input [W]	Current [A]	Locked rotor current [A]	Rated speed [min ⁻¹]	Max. airflow [m ³ /min] [CFM]	Max. static pressure [Pa] [inchH ₂ O]	SPL [dB (A)]	Operating temperature [°C]	Expected life [h]
109-180	100	50/60	5/4	0.06/0.05	0.07/0.06	2250/2700	0.27/0.33 9.5/11.7	11.8/18.6 0.047/0.075	24/26	-30 to +70	25000/60°C (56000/40°C)
109-183	115				0.06/0.05						

- Rated voltage This is the necessary voltage to drive the fan. Single-phase 100, 115, 200 and 230 VAC are also available.
- Frequency This is a frequency of alternating current (AC). The frequencies of 50 Hz and 60 Hz are existing in Japan.
Performance of AC fan varies depending on the frequency. Example: Rated speed 2250/2700 = 50 Hz → 2250, 60 Hz → 2700
- Input The power value when the fan is operating at rated voltage (at free air).
- Current The current when the fan is operating at rated voltage (at free air).
- Locked rotor current This is a current when rotor of motor that applies rated voltage is locked.
- Rated speed The speed when the fan is operating at rated voltage (at free air).
- Max. airflow The maximum airflow that the fan can generate during rated operation (measured with our double chamber measuring device).
Airflow is the volume of air generated by the fan per unit of time.
- Max. static pressure The maximum static pressure value that the fan can produce during rated operation (measured with our double chamber measuring device).
Static pressure indicates a fan's ability to move air against resistance due to the internal structure of the device to which the fan is installed.
- SPL SPL stands for Sound Pressure Level. The noise level during the fan's rated operation.
Please refer to the technical material section for the measurement method.
- Operating temperature The temperature range over which fan operation is guaranteed (Non- condensing).
- Expected life Service life hours that 90% of bearings will survive without failing when continuously operated at the rated voltage and 60°C temperature. Expected life at 40°C is for reference only.
For more information, please refer to the technical material section.



60×60×28 mm

San Ace 60

General Specifications

- Material Frame: Aluminum, Impeller: Plastic (Flammability: UL 94V-1)
- Expected life See the table below. (L10 life: 90% survival rate for continuous operation in free air at 60°C, rated voltage) Expected life at 40°C is for reference only.
- Motor structure Shaded coil motor
- Motor protection function Locked rotor burnout protection, Reverse polarity protection
For details, please refer to p. 599.
- Dielectric strength 50/60 Hz, 1500 VAC, for 1 minute (between lead wire conductors and frame)
- Insulation resistance 10 MΩ or more with a 500 VDC megger
- Sound pressure level (SPL) At 1 m away from the air inlet
- Operating voltage range Voltage of each model ±10%
- Storage temperature -30 to +70°C (Non-condensing)
- Lead wire Black, 2 pcs
- Mass 120 g

Specifications

Model no.	Rated voltage [V]	Frequency [Hz]	Input [W]	Current [A]	Locked rotor current [A]	Rated speed [min ⁻¹]	Max. airflow [m ³ /min] [CFM]	Max. static pressure [Pa] [inchH ₂ O]	SPL [dB (A)]	Operating temperature [°C]	Expected life [h]
109-180	100	50/60	5/4	0.06/0.05	0.07/0.06	2250/2700	0.27/0.33 9.5/11.7	11.8/18.6 0.047/0.075	24/26	-30 to +70	25000/60°C (56000/40°C)
109-183	115				0.06/0.05						

Note: These are Short Lead Time Service applicable models. Contact your point of sale for stock availability. For more information on the service, see p. 654.

Set Models

Fan, finger guard, plug cord, screws, etc. can be purchased in one package. For details, please refer to p. 655.

Order no.	Set items					
	Fan	Voltage	Low-speed sensor	Plug cord	Finger guards	Mounting screws
ST1-109-180	109-180	100 V		Plug cord is not included because of the exposed-lead structure.	109-139E	M4×40 mm (4 screws)
ST1-109-183	109-183	115 V			109-139E	

Airflow - Static Pressure Characteristics

109-180, 109-183

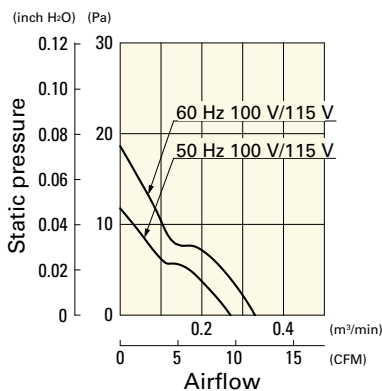

Dimensions (unit: mm)

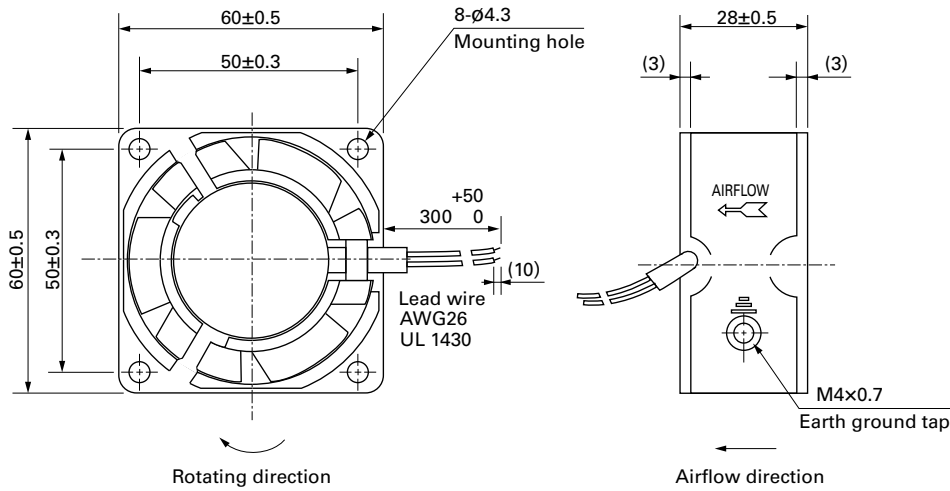

Reference Dimensions of Mounting Holes and Vent Opening (unit: mm)

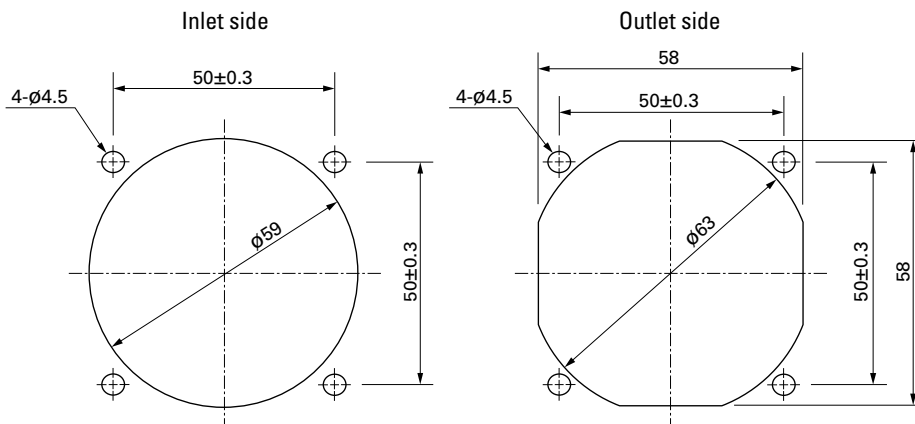

Wiring Diagram

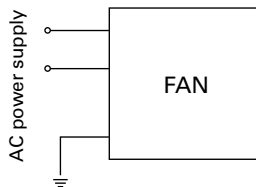

Options

Finger guards

page: p. 584

Model no.: 109-139E, 109-139H

Resin finger guards

page: p. 591

Model no.: 109-1003G

Resin filter kits

page: p. 592

Model no.: 109-1003F13 (13PPI), 109-1003F20 (20PPI),
109-1003F30 (30PPI), 109-1003F40 (40PPI)



60×60×38 mm

San Ace 60

General Specifications

- Material Frame: Aluminum, Impeller: Plastic (Flammability: UL 94V-1)
- Expected life See the table below. (L10 life: 90% survival rate for continuous operation in free air at 60°C, rated voltage) Expected life at 40°C is for reference only.
- Motor structure Shaded coil motor
- Motor protection function Locked rotor burnout protection, Reverse polarity protection
For details, please refer to p. 599.
- Dielectric strength 50/60 Hz, 1500 VAC, for 1 minute (between lead wire conductors and frame)
- Insulation resistance 10 MΩ or more with a 500 VDC megger
- Sound pressure level (SPL) At 1 m away from the air inlet
- Operating voltage range Voltage of each model ±10%
- Storage temperature -30 to +70°C (Non-condensing)
- Lead wire Black, 2 pcs
- Mass 170 g

Specifications

Model no.	Rated voltage [V]	Frequency [Hz]	Input [W]	Current [A]	Locked rotor current [A]	Rated speed [min ⁻¹]	Max. airflow [m ³ /min] [CFM]	Max. static pressure [Pa] [inchH ₂ O]	SPL [dB (A)]	Operating temperature [°C]	Expected life [h]
109-130	100	50/60	6/5	0.08/0.07	0.08/0.07	2600/3150	0.33/0.4 11.7/14.1	16.3/23.3 0.065/0.094	28/30	-30 to +60	25000/60°C (56000/40°C)
109-133	115			0.07/0.06	0.07/0.06						

Note: These are Short Lead Time Service applicable models. Contact your point of sale for stock availability. For more information on the service, see p. 654.

Set Models

Fan, finger guard, plug cord, screws, etc. can be purchased in one package. For details, please refer to p. 655.

Order no.	Set items					
	Fan	Voltage	Low-speed sensor	Plug cord	Finger guards	Mounting screws
ST1-109-130	109-130	100 V		Plug cord is not included because of the exposed-lead structure.	109-139E	M4×55 mm (4 screws)
ST1-109-133	109-133	115 V			109-139E	

Airflow - Static Pressure Characteristics

109-130, 109-133

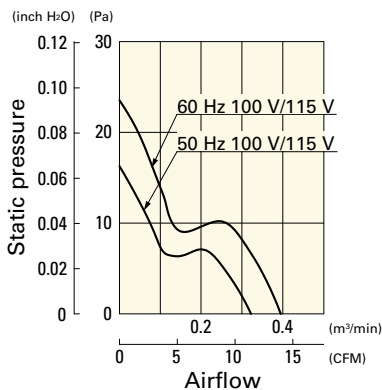

Dimensions (unit: mm)

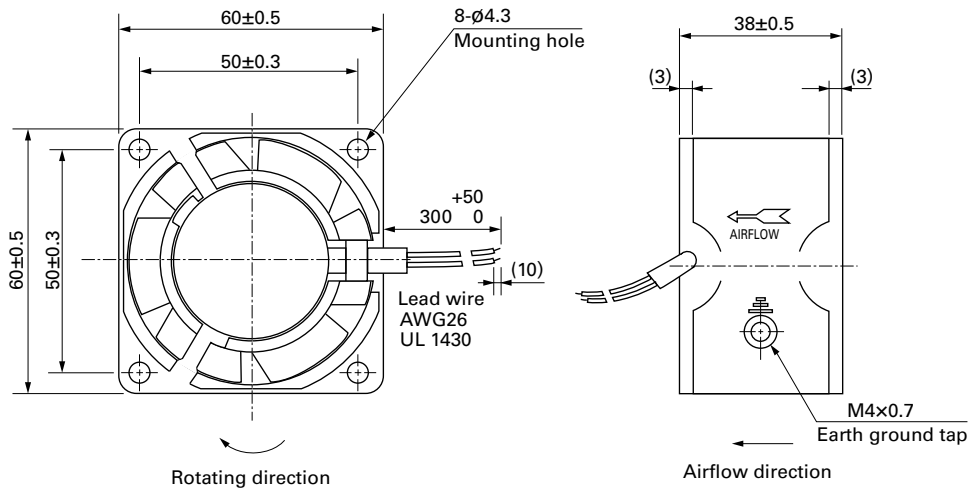

Reference Dimensions of Mounting Holes and Vent Opening (unit: mm)

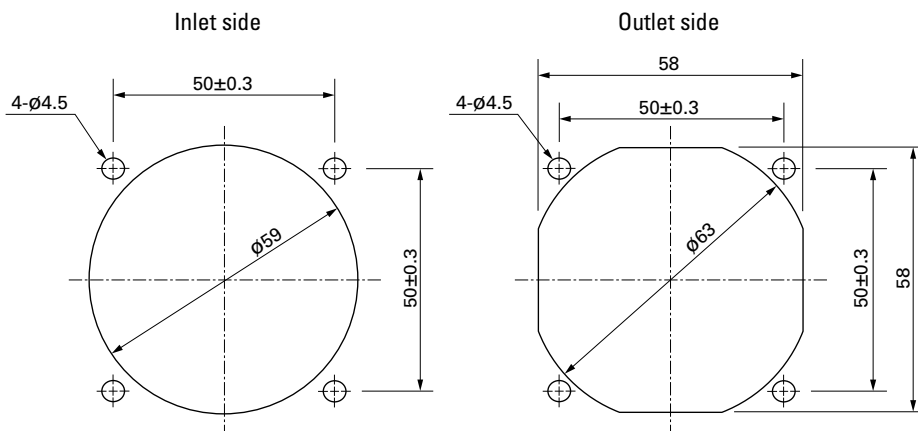

Wiring Diagram

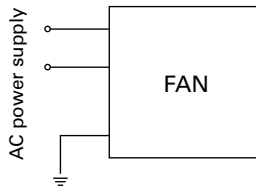

Options

Finger guards

page: p. 584

Model no.: 109-139E, 109-139H

Resin finger guards

page: p. 591

Model no.: 109-1003G

Resin filter kits

page: p. 592

Model no.: 109-1003F13 (13PPI), 109-1003F20 (20PPI),
109-1003F30 (30PPI), 109-1003F40 (40PPI)



80×80×20 mm

San Ace 80

General Specifications

- Material Frame: Aluminum, Impeller: Plastic (Flammability: UL 94V-1)
- Expected life See the table below. (L10 life: 90% survival rate for continuous operation in free air at 60°C, rated voltage) Expected life at 40°C is for reference only.
- Motor structure Shaded coil motor
- Motor protection function Locked rotor burnout protection, Reverse polarity protection
For details, please refer to p. 599.
- Dielectric strength 50/60 Hz, 1500 VAC, for 1 minute (between lead wire conductors and frame)
- Insulation resistance 10 MΩ or more with a 500 VDC megger
- Sound pressure level (SPL) At 1 m away from the air inlet
- Operating voltage range Voltage of each model ±10%
- Storage temperature -30 to +70°C (Non-condensing)
- Lead wire Black, 2 pcs
- Mass 180 g

Specifications

Model no.	Rated voltage [V]	Frequency [Hz]	Input [W]	Current [A]	Locked rotor current [A]	Rated speed [min ⁻¹]	Max. airflow [m ³ /min] [CFM]	Max. static pressure [Pa] [inchH ₂ O]	SPL [dB (A)]	Operating temperature [°C]	Expected life [h]
109-210	100	50/60	6/5	0.07/0.06	0.07/0.06	2500/3000	0.44/0.53 15.5/18.7	23.5/31.4 0.094/0.126	26/31	-30 to +60	25000/60°C (56000/40°C)
109-213	115			0.06/0.05	0.06/0.05						

Note: These are Short Lead Time Service applicable models. Contact your point of sale for stock availability. For more information on the service, see p. 654.

Set Models

Fan, finger guard, plug cord, screws, etc. can be purchased in one package. For details, please refer to p. 655.

Order no.	Set items					
	Fan	Voltage	Low-speed sensor	Plug cord	Finger guards	Mounting screws
ST1-109-210	109-210	100 V		Plug cord is not included because of the exposed-lead structure.	109-049E	M4×40 mm (4 screws)
ST1-109-213	109-213	115 V			109-049E	

Airflow - Static Pressure Characteristics

109-210, 109-213

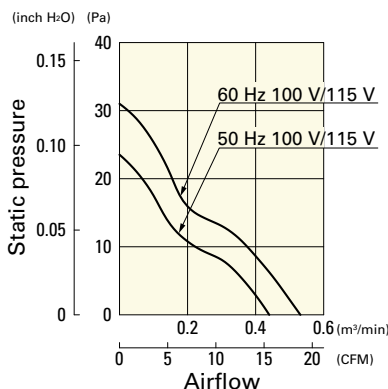

■ Dimensions (unit: mm)

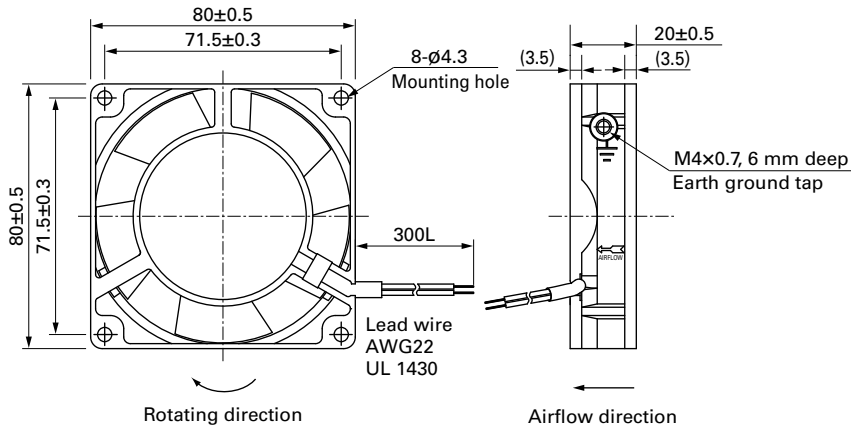

■ Reference Dimensions of Mounting Holes and Vent Opening (unit: mm)

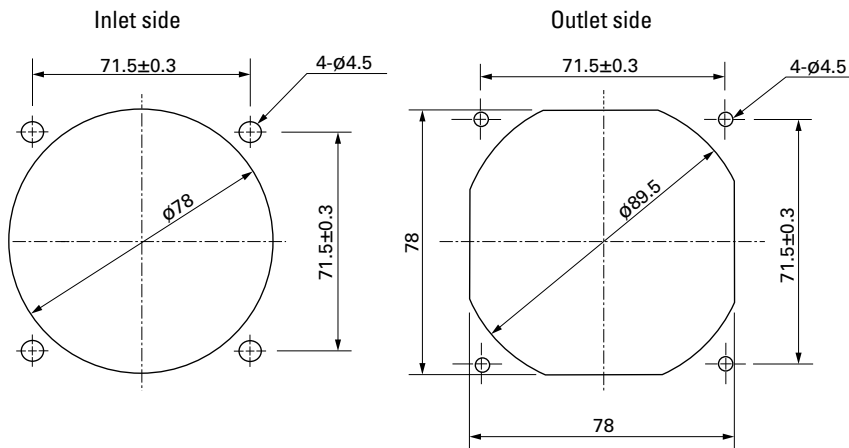

■ Wiring Diagram

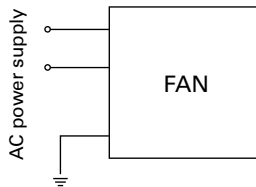

■ Options

Finger guards

page: p. 584

Model no.: 109-049E, 109-049H, 109-049C

Resin finger guards

page: p. 591

Model no.: 109-1002G

Resin filter kits

page: p. 592

Model no.: 109-1002F13 (13PPI), 109-1002F20 (20PPI),
109-1002F30 (30PPI), 109-1002F40 (40PPI)



80×80×25 mm

San Ace 80

General Specifications

- Material Frame: Aluminum, Impeller: Plastic (Flammability: UL 94V-1)
- Expected life See the table below. (L10 life: 90% survival rate for continuous operation in free air at 60°C, rated voltage) Expected life at 40°C is for reference only.
- Motor structure Shaded coil motor
- Motor protection function Locked rotor burnout protection, Reverse polarity protection
For details, please refer to p. 599.
- Dielectric strength 50/60 Hz, 1500 VAC, for 1 minute (between input terminal and frame)
- Insulation resistance 10 MΩ or more with a 500 VDC megger
- Sound pressure level (SPL) At 1 m away from the air inlet
- Operating voltage range Voltage of each model ±10%
- Storage temperature -30 to +70°C (Non-condensing)
- Mass 270 g

Specifications

Model no.	Rated voltage [V]	Frequency [Hz]	Input [W]	Current [A]	Locked rotor current [A]	Rated speed [min ⁻¹]	Max. airflow [m ³ /min] [CFM]	Max. static pressure [Pa] [inchH ₂ O]	SPL [dB (A)]	Operating temperature [°C]	Expected life [h]
109S050	100	50/60	9/7	0.12/0.1	0.13/0.11	2650/3100	0.63/0.76 22.3/26.9	27.5/38.3 0.11 /0.154	30/33	-30 to +60	25000/60°C (56000/40°C)
109S053	115			0.1 /0.08	0.11/0.09						
109S051	200			0.06/0.05	0.06/0.05						
109S054	230			0.05/0.04	0.05/0.04						
109S030	100			0.12/0.1	0.13/0.11	2350/2700	0.55/0.63 19.4/22.3	21.6/28.4 0.087/0.114	28/30		
109S033	115			0.1 /0.08	0.11/0.09						
109S031	200			0.06/0.05	0.06/0.05						
109S034	230			0.05/0.04	0.05/0.04						

Note: These are Short Lead Time Service applicable models. Contact your point of sale for stock availability. For more information on the service, see p. 654.

Set Models

Fan, finger guard, plug cord, screws, etc. can be purchased in one package. For details, please refer to p. 655.

Order no.	Set items					
	Fan	Voltage	Low-speed sensor	Plug cord ⁽¹⁾	Finger guards	Mounting screws
ST1-109S050	109S050	100 V		489-016-L10	109-049E	M4×40 mm (4 screws) ⁽²⁾
ST1-109S053	109S053	115 V		489-016-L10	109-049E	
ST1-109S051	109S051	200 V		489-016-L10	109-049E	
ST1-109S054	109S054	230 V		489-016-L10	109-049E	
ST1-109S030	109S030	100 V		489-016-L10	109-049E	
ST1-109S033	109S033	115 V		489-016-L10	109-049E	
ST1-109S031	109S031	200 V		489-016-L10	109-049E	
ST1-109S034	109S034	230 V		489-016-L10	109-049E	

(1) PSE compatible.

(2) Though these are 2-hole or 3-hole frame mount types, 4 screws are included for extra.

Airflow - Static Pressure Characteristics

109S050, 109S053, 109S051, 109S054

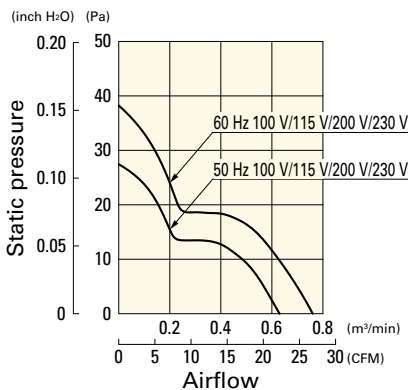

109S030, 109S033, 109S031, 109S034

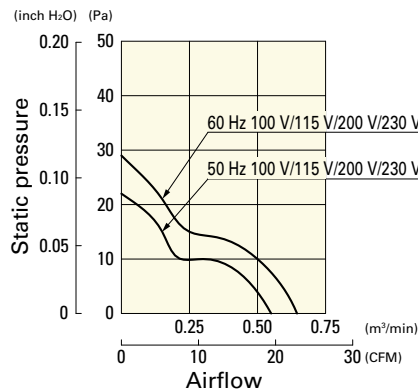

Dimensions (unit: mm)

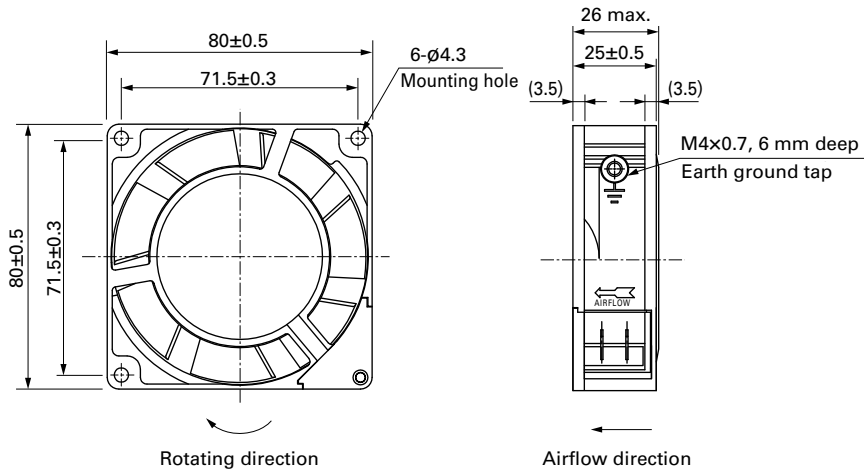

Reference Dimensions of Mounting Holes and Vent Opening (unit: mm)

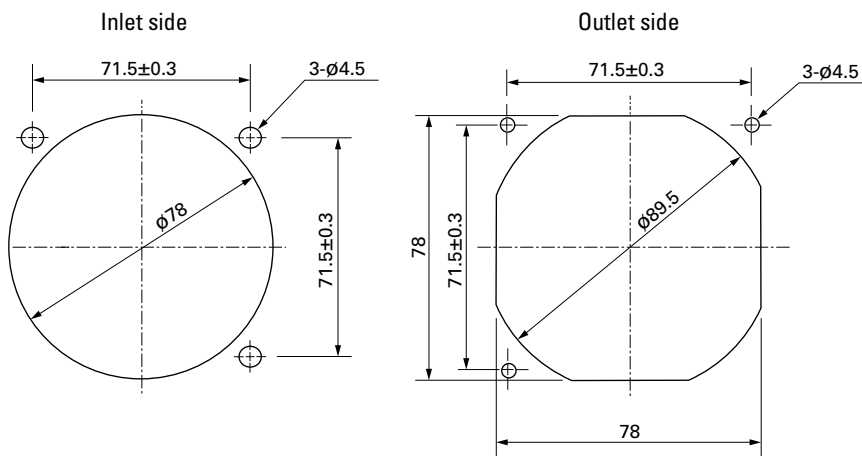

Wiring Diagram

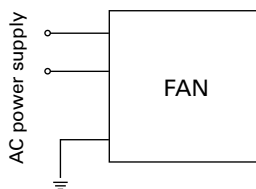

Options

Finger guards

page: p. 584

Model no.: 109-049E, 109-049H, 109-049C

Resin finger guards

page: p. 591

Model no.: 109-1002G

Resin filter kits

page: p. 592

Model no.: 109-1002F13 (13PPI), 109-1002F20 (20PPI),
109-1002F30 (30PPI), 109-1002F40 (40PPI)

Plug cord

page: pp. 594 to 595

Model no.: 489-016-L10, 489-016-L21, 489-047-L10,
489-047-L21



80×80×38 mm

San Ace 80

General Specifications

- Material Frame: Aluminum, Impeller: Plastic (Flammability: UL 94V-1)
- Expected life See the table below. (L10 life: 90% survival rate for continuous operation in free air at 60°C, rated voltage) Expected life at 40°C is for reference only.
- Motor structure Shaded coil motor
- Motor protection function Locked rotor burnout protection, Reverse polarity protection
For details, please refer to p. 599.
- Dielectric strength 50/60 Hz, 1500 VAC, for 1 minute (between input terminal and frame)
- Insulation resistance 10 MΩ or more with a 500 VDC megger
- Sound pressure level (SPL) At 1 m away from the air inlet
- Operating voltage range Voltage of each model ±10%
- Storage temperature -30 to +70°C (Non-condensing)
- Mass 400 g

Specifications

Model no.	Rated voltage [V]	Frequency [Hz]	Input [W]	Current [A]	Locked rotor current [A]	Rated speed [min ⁻¹]	Max. airflow [m ³ /min] [CFM]	Max. static pressure [Pa] [inchH ₂ O]	SPL [dB (A)]	Operating temperature [°C]	Expected life [h]
109-150	100	50/60	9/8	0.13/0.11	0.17/0.15	2700/3150	0.9/1.05 31.8/37.1	31.4/44.1 0.126/0.177	35/39	-30 to +60	25000/60°C (56000/40°C)
109-153	115			0.11/0.1	0.14/0.12						
109-151	200			0.07/0.06	0.09/0.08						
109-154	230			0.06/0.05	0.08/0.07						

Note: These are Short Lead Time Service applicable models. Contact your point of sale for stock availability. For more information on the service, see p. 654.

Set Models

Fan, finger guard, plug cord, screws, etc. can be purchased in one package. For details, please refer to p. 655.

Order no.	Set items					
	Fan	Voltage	Low-speed sensor	Plug cord ⁽¹⁾	Finger guards	Mounting screws
ST1-109-150	109-150	100 V		489-016-L10	109-049E	M4×55 mm (4 screws) ⁽²⁾
ST1-109-153	109-153	115 V		489-016-L10	109-049E	
ST1-109-151	109-151	200 V		489-016-L10	109-049E	
ST1-109-154	109-154	230 V		489-016-L10	109-049E	

(1) PSE compatible.

(2) Though these are 2-hole or 3-hole frame mount types, 4 screws are included for extra.

Airflow - Static Pressure Characteristics

109-150, 109-153, 109-151, 109-154

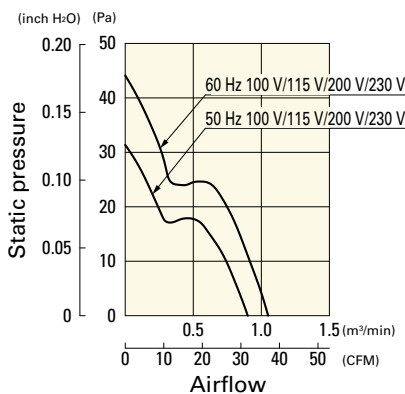

Dimensions (unit: mm)

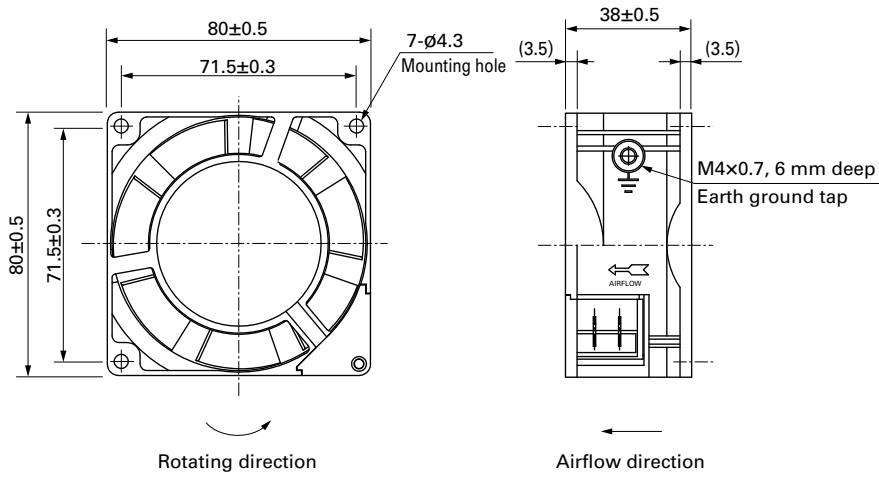

Reference Dimensions of Mounting Holes and Vent Opening (unit: mm)

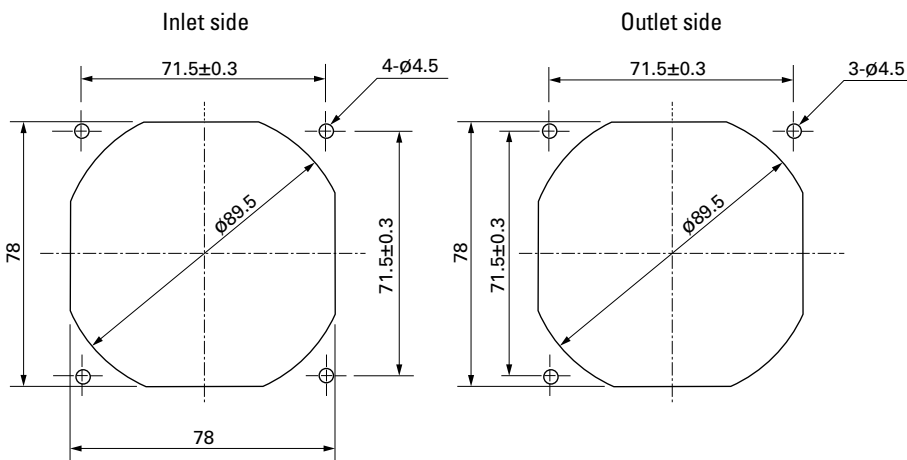

Wiring Diagram

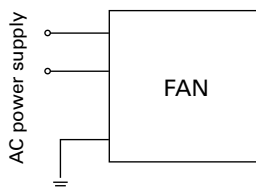

Options

Finger guards

page: p. 584

Model no.: 109-049E, 109-049H, 109-049C

Resin finger guards

page: p. 591

Model no.: 109-1002G

Resin filter kits

page: p. 592

Model no.: 109-1002F13 (13PPI), 109-1002F20 (20PPI),
109-1002F30 (30PPI), 109-1002F40 (40PPI)

Plug cord

page: pp. 594 to 595

Model no.: 489-016-L10, 489-016-L21, 489-047-L10,
489-047-L21



80×80×42 mm

San Ace 80

General Specifications

- Material Frame: Aluminum (Black coating), Impeller: Plastic (Flammability: UL 94V-1)
- Expected life See the table below. (L10 life: 90% survival rate for continuous operation in free air at 60°C, rated voltage) Expected life at 40°C is for reference only.
- Motor structure Shaded coil motor
- Motor protection function Locked rotor burnout protection, Reverse polarity protection
For details, please refer to p. 599.
- Dielectric strength 50/60 Hz, 1500 VAC, for 1 minute (between input terminal and frame)
- Insulation resistance 10 MΩ or more with a 500 VDC megger
- Sound pressure level (SPL) At 1 m away from the air inlet
- Operating voltage range Voltage of each model ±10%
- Storage temperature -30 to +70°C (Non-condensing)
- Mass 410 g

Specifications

Model no.	Rated voltage [V]	Frequency [Hz]	Input [W]	Current [A]	Locked rotor current [A]	Rated speed [min ⁻¹]	Max. airflow [m ³ /min] [CFM]	Max. static pressure [Pa] [inchH ₂ O]	SPL [dB (A)]	Operating temperature [°C]	Expected life [h]
109-040UL	100	50/60	10/9	0.13/0.11	0.16/0.14	2650/3100	0.85/1.0 30.0/35.3	24.5/35.3 0.098/0.142	40/44	-30 to +60	25000/60°C (56000/40°C)
109-043UL	115			0.11/0.1	0.14/0.12						
109-041UL	200			0.07/0.06	0.08/0.07						
109-044UL	230			0.06/0.05	0.07/0.06						
109-047UL*	100			0.05/0.05	0.05/0.05						
109-033UL*	115			0.04/0.04	0.04/0.04						
			4/3.5			1500/1500	0.43/0.43 15.2/15.2	8.8/ 8.8 0.035/0.035	24/24		

* These are low-speed models.

Note: These are Short Lead Time Service applicable models. Contact your point of sale for stock availability. For more information on the service, see p. 654.

Set Models

Fan, finger guard, plug cord, screws, etc. can be purchased in one package. For details, please refer to p. 655.

Order no.	Set items					
	Fan	Voltage	Low-speed sensor	Plug cord*	Finger guards	Mounting screws
ST1-109-040UL	109-040UL	100 V		489-008-L10	109-049E	M4×55 mm (4 screws)
ST1-109-043UL	109-043UL	115 V		489-008-L10	109-049E	
ST1-109-041UL	109-041UL	200 V		489-008-L10	109-049E	
ST1-109-044UL	109-044UL	230 V		489-008-L10	109-049E	
ST1-109-047UL	109-047UL	100 V		489-008-L10	109-049E	
ST1-109-033UL	109-033UL	115 V		489-008-L10	109-049E	

* PSE compatible.

Airflow - Static Pressure Characteristics

109-040UL, 109-043UL, 109-041UL, 109-044UL

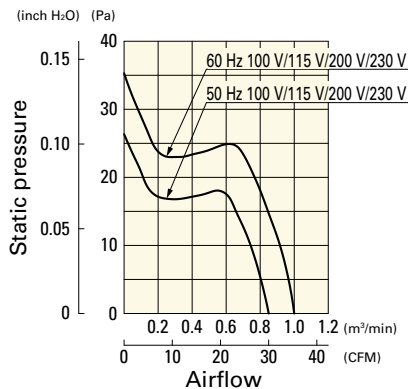

109-047UL, 109-033UL

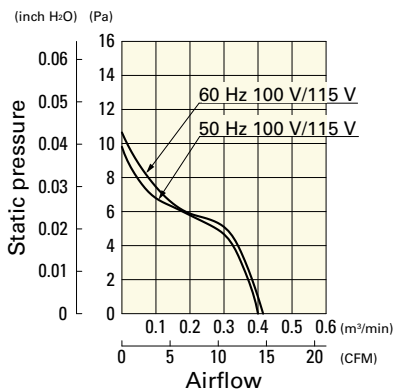

Dimensions (unit: mm)

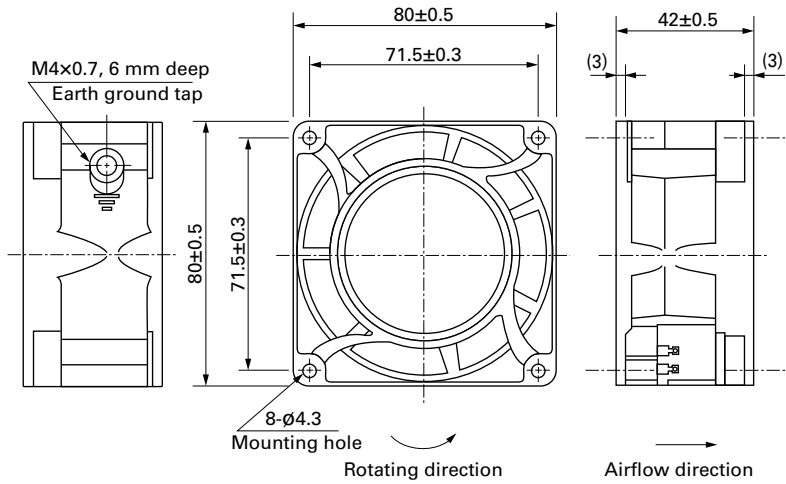

Reference Dimensions of Mounting Holes and Vent Opening (unit: mm)

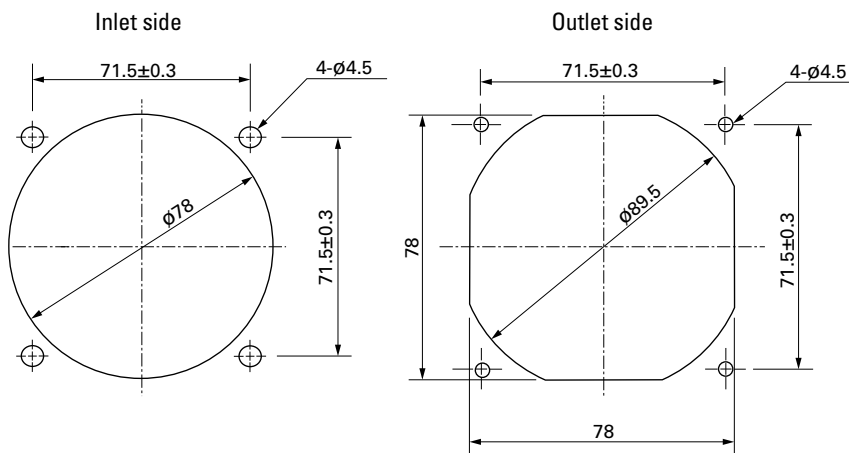

Wiring Diagram

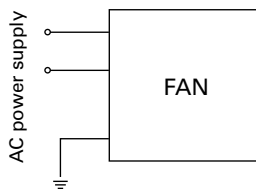

Options

Finger guards

page: p. 584

Model no.: 109-049E, 109-049H, 109-049C

Resin finger guards

page: p. 591

Model no.: 109-1002G

Resin filter kits

page: p. 592

Model no.: 109-1002F13 (13PPI), 109-1002F20 (20PPI),
109-1002F30 (30PPI), 109-1002F40 (40PPI)

Plug cord

page: p. 594

Model no.: 489-008-L10, 489-008-L21, 489-008-L35



92×92×25 mm

San Ace 92     Only standard fans (without sensors) have acquired CSA certification.

General Specifications

- Material Frame: Aluminum, Impeller: Plastic (Flammability: UL 94V-1)
- Expected life See the table below. (L10 life: 90% survival rate for continuous operation in free air at 60°C, rated voltage)
Expected life at 40°C is for reference only.
- Motor structure Shaded coil motor
- Motor protection function Locked rotor burnout protection, Reverse polarity protection
For details, please refer to p. 599.
- Dielectric strength 50/60 Hz, 1500 VAC, for 1 minute (between input terminal and frame)
- Dielectric strength (with sensor) 50/60 Hz 1500 VAC 1 minute (between AC input terminal and frame)
50/60 Hz 1000 VAC 1 minute (between lead wire conductors and frame)
- Insulation resistance 10 MΩ or more with a 500 VDC megger
- Sound pressure level (SPL) At 1 m away from the air inlet
- Operating voltage range Voltage of each model ±10%
- Storage temperature -30 to +70°C (Non-condensing)
- Sensor-Purpose lead wire ⊕Brown ⊖Black (Sensor) Yellow
- Mass 290 g/310 g (with Sensor)

Specifications

Standard

Model no.	Rated voltage [V]	Frequency [Hz]	Input [W]	Current [A]	Locked rotor current [A]	Rated speed [min ⁻¹]	Max. airflow [m ³ /min] [CFM]	Max. static pressure [Pa] [inchH ₂ O]	SPL [dB (A)]	Operating temperature [°C]	Expected life [h]
109S091	100	50/60	8/7	0.1 /0.09	0.13/0.12	2700/3100	0.95/1.1 33.6/38.9	39.2/49.0 0.157/0.197	35/38	-30 to +60	25000/60°C (56000/40°C)
109S093	115			0.09/0.08	0.11/0.1						
109S092	200		11/10	0.07/0.06	0.08/0.08						
109S094	230		10/9	0.06/0.05	0.07/0.07						
109S095	100		8/7	0.1 /0.09	0.11/0.1	2400/2800	0.84/0.98 29.7/34.6	31.4/40.2 0.126/0.161	32/35		
109S096*	100		7/6	0.09/0.08	0.09/0.08	1500/1700	0.55/0.65 19.4/23	12.5/16.3 0.05 /0.065	24/27		
109S193*	115			0.08/0.07	0.08/0.07						
109S192*	200		8/7	0.06/0.05	0.06/0.05						
109S194*	230			0.05/0.04	0.05/0.04						

*These are low-speed models.

with Sensor

For sensor specifications, please refer to p. 602. Sensor specification differs depending on the fan's speed specification.

For a 5 V sensor power supply (ITEM-20), please append "-20" to the end of model number. E.g. 109S491-20

For a 12 V sensor power supply (ITEM-30), please append "-30" to the end of model number. E.g. 109S491-30

Model no.	Rated voltage [V]	Frequency [Hz]	Input [W]	Current [A]	Locked rotor current [A]	Rated speed [min ⁻¹]	Max. airflow [m ³ /min] [CFM]	Max. static pressure [Pa] [inchH ₂ O]	SPL [dB (A)]	Operating temperature [°C]	Expected life [h]
109S491	100	50/60	8/7	0.1 /0.09	0.13/0.12	2700/3100	0.95/1.1 33.6/38.9	39.2/49.0 0.157/0.197	35/38	-10 to +60	25000/60°C (56000/40°C)
109S493	115			0.09/0.08	0.11/0.1						
109S492	200		11/10	0.07/0.06	0.08/0.08						
109S494	230		10/9	0.06/0.05	0.07/0.07						
109S495	100		8/7	0.1 /0.09	0.11/0.1	2400/2800	0.84/0.98 29.7/34.6	31.4/40.2 0.126/0.161	32/35		
109S496*			7/6	0.09/0.08	0.09/0.08	1500/1700	0.55/0.65 19.4/23	12.5/16.3 0.05 /0.065	24/27		

*These are low-speed models.

Note: These are Short Lead Time Service applicable models. Contact your point of sale for stock availability. For more information on the service, see p. 654.

For the **San Ace 92AD** 9AD type **92×92×38** mm fan, please refer to p. 516.

This fan works while internally converting AC power into DC power, providing the superior performance of a DC fan with the flexibility of AC input.

Set Models

Fan, finger guard, plug cord, screws, etc. can be purchased in one package. For details, please refer to p. 655.

Order no.	Set items					
	Fan	Voltage	Low-speed sensor	Plug cord ⁽¹⁾	Finger guards	Mounting screws
ST1-109S091	109S091	100 V		489-016-L10	109-099E	M3×40 mm (4 screws) ⁽²⁾
ST1-109S093	109S093	115 V		489-016-L10	109-099E	
ST1-109S092	109S092	200 V		489-016-L10	109-099E	
ST1-109S094	109S094	230 V		489-016-L10	109-099E	
ST1-109S095	109S095	100 V		489-016-L10	109-099E	
ST1-109S096	109S096	100 V		489-016-L10	109-099E	
ST1-109S193	109S193	115 V		489-016-L10	109-099E	
ST1-109S192	109S192	200 V		489-016-L10	109-099E	
ST1-109S194	109S194	230 V		489-016-L10	109-099E	
ST1-109S491-20	109S491-20	100 V	○ (5 V)	489-016-L10	109-099E	
ST1-109S491-30	109S491-30		○ (12 V)	489-016-L10	109-099E	
ST1-109S493-20	109S493-20	115 V	○ (5 V)	489-016-L10	109-099E	
ST1-109S493-30	109S493-30		○ (12 V)	489-016-L10	109-099E	
ST1-109S492-20	109S492-20	200 V	○ (5 V)	489-016-L10	109-099E	
ST1-109S492-30	109S492-30		○ (12 V)	489-016-L10	109-099E	
ST1-109S494-20	109S494-20	230 V	○ (5 V)	489-016-L10	109-099E	
ST1-109S494-30	109S494-30		○ (12 V)	489-016-L10	109-099E	
ST1-109S495-20	109S495-20	100 V	○ (5 V)	489-016-L10	109-099E	
ST1-109S495-30	109S495-30		○ (12 V)	489-016-L10	109-099E	
ST1-109S496-20	109S496-20		○ (5 V)	489-016-L10	109-099E	
ST1-109S496-30	109S496-30		○ (12 V)	489-016-L10	109-099E	

(1) PSE compatible.

(2) Though these are 2-hole or 3-hole frame mount types, 4 screws are included for extra.

Airflow - Static Pressure Characteristics

Standard

109S091, 109S093, 109S092, 109S094

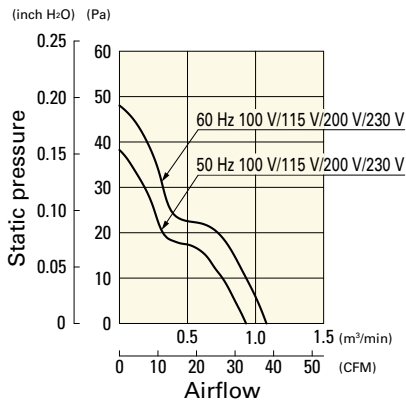

109S095

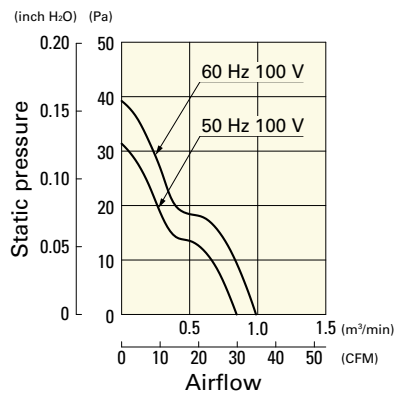

109S096, 109S193, 109S192, 109S194

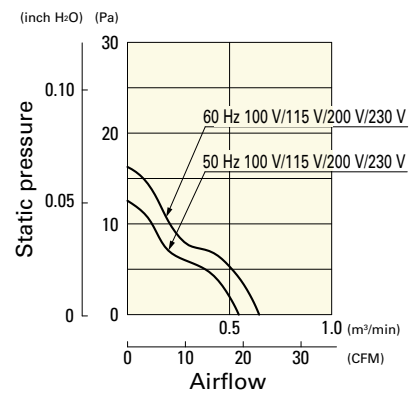

with Sensor

109S491, 109S493, 109S492, 109S494

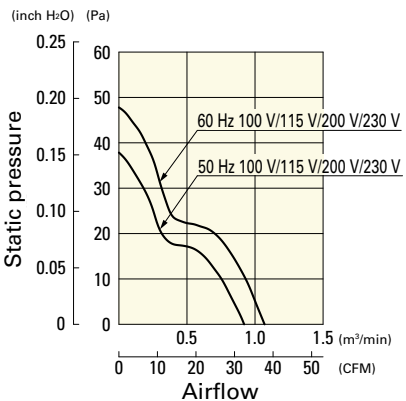

109S495

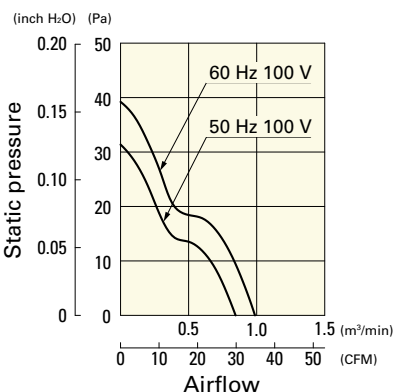

109S496

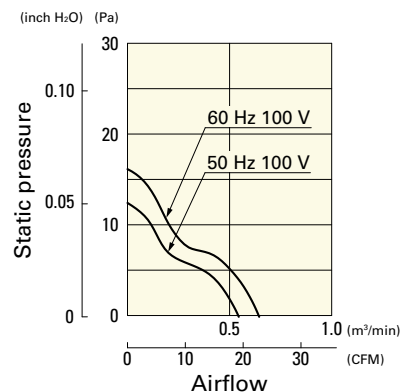

Dimensions (unit: mm)

Standard

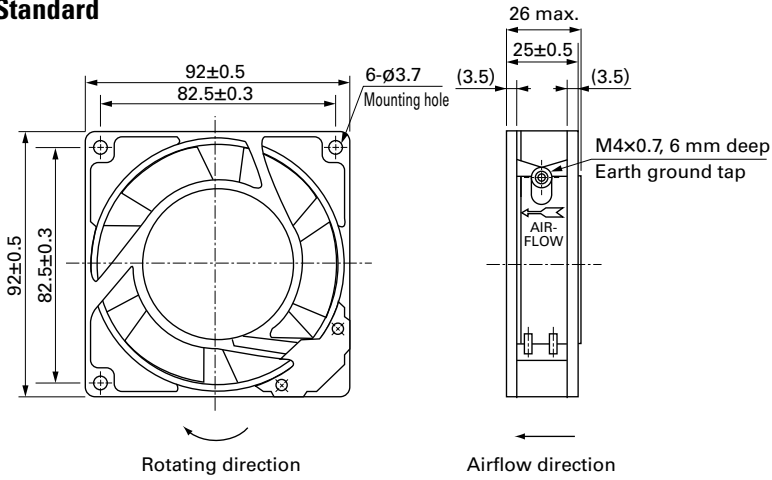

with Sensor

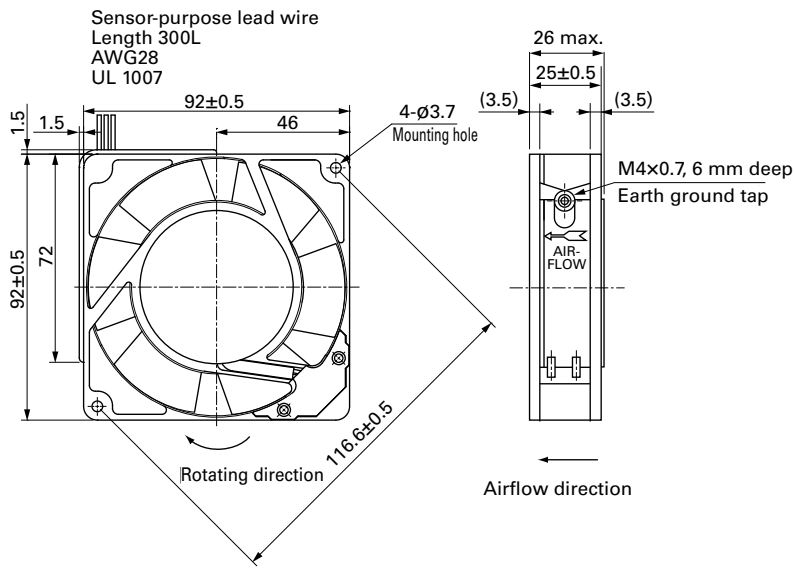

AC

AC Fan 92 mm sq.

Reference Dimensions of Mounting Holes and Vent Opening (unit: mm)

Standard

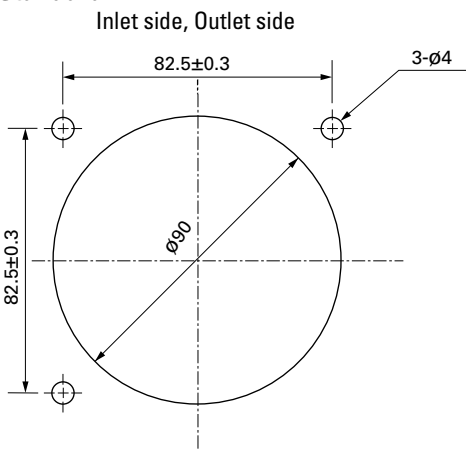

with Sensor

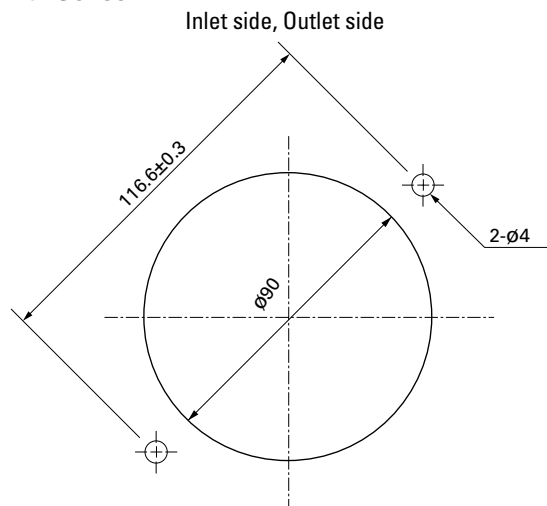

Wiring Diagram

Standard

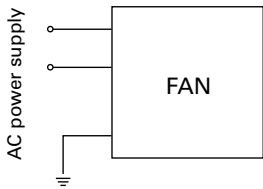

with Sensor

For fan power supply

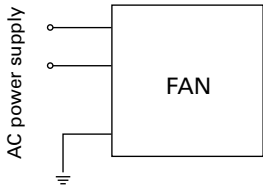

For sensor circuit
5 V (ITEM-20)

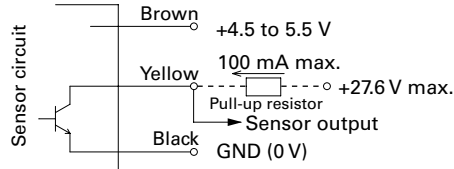

12 V (ITEM-30)

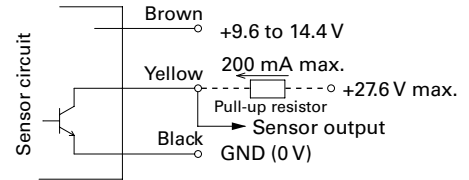

GND (Black) should be shared in case that power supply for sensor circuit (Brown) and that for sensor pull-up (Yellow) are separated.

Options

Finger guards

page: p. 584

Model no.: 109-099E, 109-099H, 109-099C

Resin finger guards

page: p. 591

Model no.: 109-1001G

Resin filter kits

page: p. 592

Model no.: 109-1001F13 (13PPI), 109-1001F20 (20PPI),
109-1001F30 (30PPI), 109-1001F40 (40PPI)

Plug cord

page: pp. 594 to 595

Model no.: 489-016-L10, 489-016-L21, 489-047-L10,
489-047-L21



120×120×25 mm

San Ace 120 Only standard fans (without sensors) have acquired CSA certification.

General Specifications

- Material Frame: Aluminum, Impeller: Plastic (Flammability: UL 94V-1)
- Expected life See the table below. (L10 life: 90% survival rate for continuous operation in free air at 60°C, rated voltage) Expected life at 40°C is for reference only.
- Motor structure Shaded coil motor
- Motor protection function Locked rotor burnout protection, Reverse polarity protection
For details, please refer to p. 599.
- Dielectric strength 50/60 Hz, 1500 VAC, for 1 minute (between input terminal and frame)
- Dielectric strength (with sensor) 50/60 Hz 1500 VAC 1 minute (between AC input terminal and frame)
50/60 Hz 1000 VAC 1 minute (between lead wire conductors and frame)
- Insulation resistance 10 MΩ or more with a 500 VDC megger
- Sound pressure level (SPL) At 1 m away from the air inlet
- Operating voltage range Voltage of each model ±10%
- Storage temperature -30 to +70°C (Non-condensing)
- Sensor-Purpose lead wire ⊕Brown ⊖Black (Sensor) Yellow
- Mass 370 g/390 g (with Sensor)

Specifications

Standard

Model no.	Rated voltage [V]	Frequency [Hz]	Input [W]	Current [A]	Locked rotor current [A]	Rated speed [min ⁻¹]	Max. airflow [m ³ /min] [CFM]	Max. static pressure [Pa] [inchH ₂ O]	SPL [dB (A)]	Operating temperature [°C]	Expected life [h]
109S085	100	50/60	13.5/12	0.16/0.14	0.19/0.17	2500/2900	1.95/2.3 68.9/81.3	48 /51.9 0.193/0.216	38/41	-30 to +60	25000/60°C (56000/40°C)
109S084	115			0.14/0.12	0.16/0.15						
109S088	200			0.08/0.07	0.1 /0.09						
109S087	230			0.07/0.06	0.08/0.07						
109S081	100	9.5/8.5	9.5/8.5	0.11	0.11/0.1	2200/2350	1.7 /1.8 60.1/63.6	29.4/26.5 0.118/0.106			
109S083	115	0.1		0.1 /0.09							
109S082	200	0.07		0.07/0.06							
109S089	230	0.06		0.06/0.05							
109S086*	100	12/10	0.14/0.12	0.15/0.13	1400/1600	1.1 /1.25 38.9/44.2	14.7/18.6 0.059/0.075	24/27			

*These are low-speed models.

with Sensor

For sensor specifications, please refer to p. 602. Sensor specification differs depending on the fan's speed specification.

For a 5 V sensor power supply (ITEM-20), please append "-20" to the end of model number. E.g. 109S485-20

For a 12 V sensor power supply (ITEM-30), please append "-30" to the end of model number. E.g. 109S485-30

Model no.	Rated voltage [V]	Frequency [Hz]	Input [W]	Current [A]	Locked rotor current [A]	Rated speed [min ⁻¹]	Max. airflow [m ³ /min] [CFM]	Max. static pressure [Pa] [inchH ₂ O]	SPL [dB (A)]	Operating temperature [°C]	Expected life [h]
109S485	100	50/60	13.5/12	0.16/0.14	0.19/0.17	2500/2900	1.95/2.3 68.9/81.3	48 /51.9 0.193/0.216	38/41	-10 to +60	25000/60°C (56000/40°C)
109S484	115			0.14/0.12	0.16/0.15						
109S488	200			0.08/0.07	0.1 /0.09						
109S487	230			0.07/0.06	0.08/0.07						
109S486*	100	12/10	0.14/0.12	0.15/0.13	1400/1600	1.1 /1.25 38.9/44.2	14.7/18.6 0.059/0.075	24/27			

*These are low-speed models.

Note: These are Short Lead Time Service applicable models. Contact your point of sale for stock availability. For more information on the service, see p. 654.

Set Models

Fan, finger guard, plug cord, screws, etc. can be purchased in one package. For details, please refer to p. 655.

Order no.	Set items					
	Fan	Voltage	Low-speed sensor	Plug cord*	Finger guards	Mounting screws
ST1-109S085	109S085	100 V		489-016-L10	109-019E	M3×40 mm (4 screws)
ST1-109S084	109S084	115 V		489-016-L10	109-019E	
ST1-109S088	109S088	200 V		489-016-L10	109-019E	
ST1-109S087	109S087	230 V		489-016-L10	109-019E	
ST1-109S081	109S081	100 V		489-016-L10	109-019E	
ST1-109S083	109S083	115 V		489-016-L10	109-019E	
ST1-109S082	109S082	200 V		489-016-L10	109-019E	
ST1-109S089	109S089	230 V		489-016-L10	109-019E	
ST1-109S086	109S086			489-016-L10	109-019E	
ST1-109S485-20	109S485-20	100 V	○ (5 V)	489-016-L10	109-019E	
ST1-109S485-30	109S485-30		○ (12 V)	489-016-L10	109-019E	
ST1-109S484-20	109S484-20	115 V	○ (5 V)	489-016-L10	109-019E	
ST1-109S484-30	109S484-30		○ (12 V)	489-016-L10	109-019E	
ST1-109S488-20	109S488-20	200 V	○ (5 V)	489-016-L10	109-019E	
ST1-109S488-30	109S488-30		○ (12 V)	489-016-L10	109-019E	
ST1-109S487-20	109S487-20	230 V	○ (5 V)	489-016-L10	109-019E	
ST1-109S487-30	109S487-30		○ (12 V)	489-016-L10	109-019E	
ST1-109S486-20	109S486-20	100 V	○ (5 V)	489-016-L10	109-019E	
ST1-109S486-30	109S486-30		○ (12 V)	489-016-L10	109-019E	

* PSE compatible.

Airflow - Static Pressure Characteristics

Standard

109S085, 109S084, 109S088, 109S087

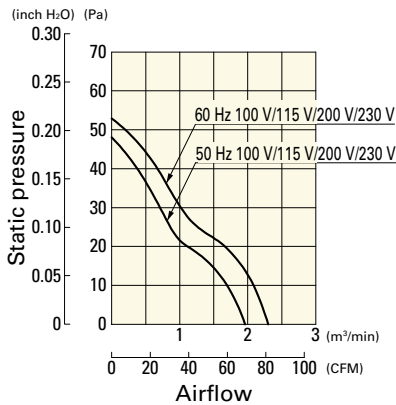

109S081, 109S083, 109S082, 109S089

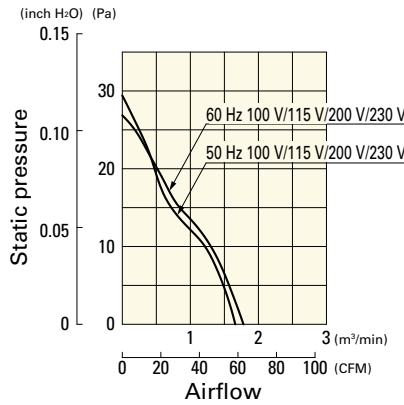

109S086

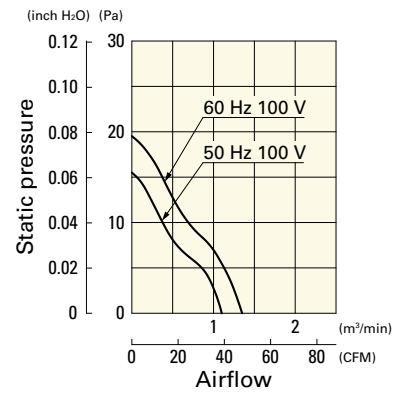

with Sensor

109S485, 109S484, 109S488, 109S487

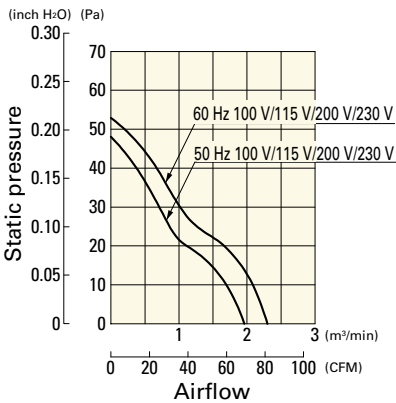

109S486

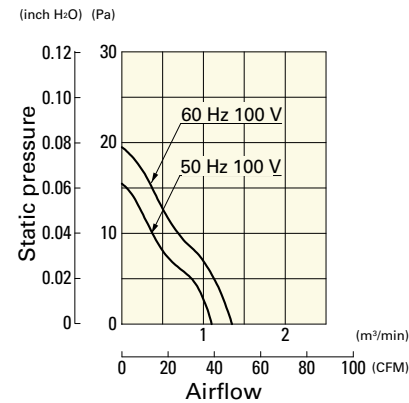

Standard

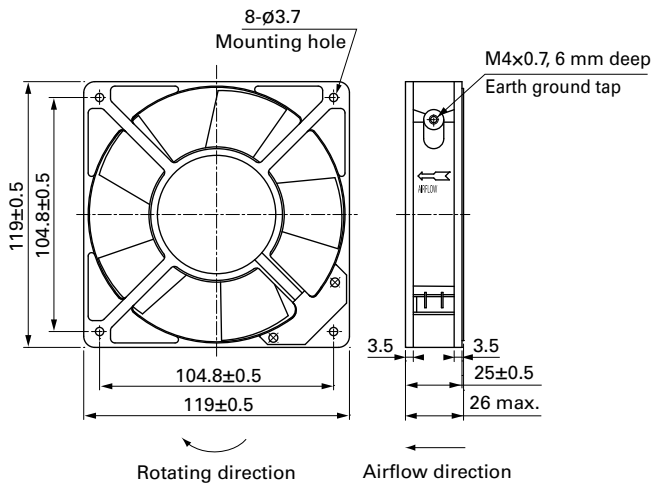

with Sensor When mounting the model with a sensor, please screw-mount through both flanges as it has a sensor box.

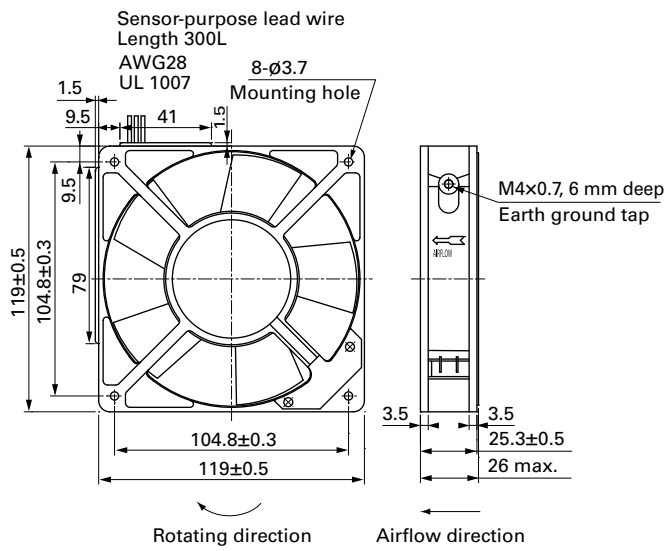

AC Fan 120 mm sq.

Reference Dimensions of Mounting Holes and Vent Opening (unit: mm)

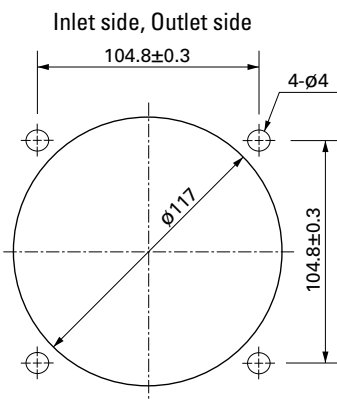

Wiring Diagram

Standard

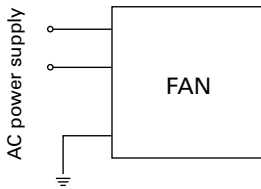

with Sensor

For fan power supply

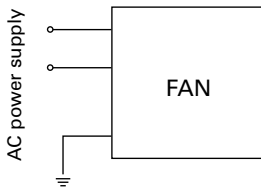

For sensor circuit
5 V (ITEM-20)

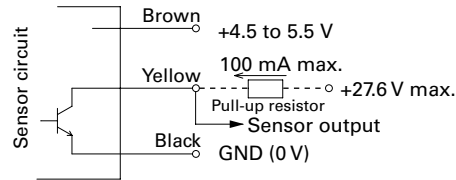

12 V (ITEM-30)

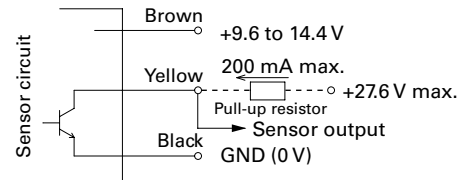

GND (Black) should be shared in case that power supply for sensor circuit (Brown) and that for sensor pull-up (Yellow) are separated.

Options

Finger guards

page: p. 585

Model no.: 109-019E, 109-019K, 109-019C, 109-019H

Resin finger guards

page: p. 591

Model no.: 109-1000G

Resin filter kits

page: p. 592

Model no.: 109-1000F13 (13PPI), 109-1000F20 (20PPI),
109-1000F30 (30PPI), 109-1000F40 (40PPI)

Plug cord

page: pp. 594 to 595

Model no.: 489-016-L10, 489-016-L21, 489-047-L10,
489-047-L21



120×120×38 mm

San Ace 120 Certifications vary by model no. Please refer to pp. 614 to 615.

General Specifications

- Material Frame: Aluminum, Impeller: Plastic (Flammability: UL 94V-1)
- Expected life See the table below. (L10 life: 90% survival rate for continuous operation in free air at 60°C, rated voltage)
Expected life at 40°C is for reference only.
- Motor structure Shaded coil motor
- Motor protection function Locked rotor burnout protection, Reverse polarity protection
For details, please refer to p. 599.
- Dielectric strength 50/60 Hz, 1500 VAC, for 1 minute (between input terminal and G terminal)
- Dielectric strength (with sensor) 50/60 Hz 1500 VAC 1 minute (between AC input terminal and G terminal)
50/60 Hz 1000 VAC 1 minute (between lead wire conductors and frame)
- Insulation resistance 10 MΩ or more with a 500 VDC megger
- Sound pressure level (SPL) At 1 m away from the air inlet
- Operating voltage range Voltage of each model ±10%
- Storage temperature -30 to +70°C (Non-condensing)
- Sensor-Purpose lead wire ⊕Brown ⊖Black (Sensor) Yellow
- Mass 550 g/580 g (with Sensor)

Specifications

Standard

Model no.	Rated voltage [V]	Frequency [Hz]	Input [W]	Current [A]	Locked rotor current [A]	Rated speed [min ⁻¹]	Max. airflow [m ³ /min] [CFM]	Max. static pressure [Pa] [inchH ₂ O]	SPL [dB (A)]	Operating temperature [°C]	Expected life [h]							
109S075UL	100	50/60	18/16	0.24/0.21	0.32/0.28	2700/3100	2.5 /2.9 88.3/102.5	57.9/68.7 0.233/0.276	42/45	-30 to +60	25000/60°C (56000/40°C)							
109S074UL	115			0.21/0.18	0.27/0.24													
109S078UL	200			0.12/0.1	0.16/0.14													
109S072UL	230			0.11/0.09	0.14/0.13													
109S005	100		14/12	0.18/0.16	0.25/0.22	2700/3100	2.35/2.7 83 / 95.4	55.9/65.7 0.224/0.264	40/43									
109S005UL					0.16/0.14							0.21/0.18						
109S024	120			0.09/0.08	0.13/0.11													
109S024UL	115			0.08/0.07	0.11/0.09													
109S008	200		14/12	0.09/0.08	0.13/0.11	2450/2700	2.15/2.35 76 / 83	44.1/49.0 0.177/0.197	38/40									
109S008UL																		
109S025	230		14/12	0.18/0.16	0.23/0.21	1800/2000	1.55/1.75 54.8/ 60.8	23.5/26.4 0.094/0.106	30/32									
109S025UL																		
109S029UL	100		7/7	0.1 /0.09	0.1 /0.09	1650/1700	1.45/1.5 51.2/ 53	17.6/17.6 0.071/0.071	28/28									
109S013												13/11	0.16/0.14	0.16/0.15	1800/1900	1.56/1.64 55 / 57.9	20 /20.6 0.08 /0.083	30/31
109S013UL																		
109S006*																		
109S006UL*	115	10/10	0.13/0.11	0.13/0.11	1800/1900	1.56/1.64 55 / 57.9	20 /20.6 0.08 /0.083	30/31										
109S010*	200	7/7	0.05/0.04	0.05/0.04	1650/1700	1.45/1.5 51.2/ 53	17.6/17.6 0.071/0.071	28/28										
109S010UL*																		
109S010UL*	240	11/11	0.06/0.05	0.06/0.05	1800/1950	1.58/1.68 55.8/ 59.3	20.6/21.6 0.083/0.087	30/32										

*These are low-speed models.

AC Fan 120 mm sq. AC

with Sensor

For sensor specifications, please refer to p. 602. Sensor specification differs depending on the fan's speed specification.

For a 5 V sensor power supply (ITEM-20), please append "-20" to the end of model number. E.g. 109S405UL-20

For a 12 V sensor power supply (ITEM-30), please append "-30" to the end of model number. E.g. 109S405UL-30

Model no.	Rated voltage [V]	Frequency [Hz]	Input [W]	Current [A]	Locked rotor current [A]	Rated speed [min ⁻¹]	Max. airflow [m ³ /min] [CFM]	Max. static pressure [Pa] [inchH ₂ O]	SPL [dB (A)]	Operating temperature [°C]	Expected life [h]
109S405UL	100	50/60	14/12	0.18/0.16	0.25/0.22	2700/3100	2.35/2.7 83 / 95.4	55.9/65.7 0.224/0.264	40/43	-10 to +60	25000/60°C (56000/40°C)
109S424UL	115			0.16/0.14	0.21/0.18						
109S408UL	200			0.09/0.08	0.13/0.11						
109S425UL	230			0.08/0.07	0.11/0.09						
109S429UL	100		7/6	0.18/0.16	0.23/0.21	2450/2700	2.15/2.35 76 / 83	44.1/49.0 0.177/0.197	38/40		
109S406UL*				0.09/0.08	0.1 /0.09	1650/1700	1.45/1.5 51 / 53	17.7/17.7 0.071/0.071	28/28		
109S475UL	100		18/16	0.24/0.21	0.32/0.28	2700/3100	2.5 /2.9 88.3/102.4	57.9/68.7 0.233/0.276	42/45		
109S474UL	115			0.21/0.18	0.27/0.24						
109S478UL	200			0.12/0.1	0.16/0.14						
109S472UL	230			0.11/0.09	0.14/0.13						

*These are low-speed models.

Note:These are Short Lead Time Service applicable models. Contact your point of sale for stock availability. For more information on the service, see p. 654.

For the San Ace 120AD 9AD type 120×120×38 mm fan, please refer to p. 519.

This fan works while internally converting AC power into DC power, providing the superior performance of a DC fan with the flexibility of AC input.

Set Models

Fan, finger guard, plug cord, screws, etc. can be purchased in one package. For details, please refer to p. 655.

Order no.	Set items						Mounting screws
	Fan	Voltage	Low-speed sensor	Plug cord*	Finger guards		
ST1-109S075UL	109S075UL	100 V		489-037-L10	109-019E	M3×55 mm (4 screws)	
ST1-109S074UL	109S074UL	115 V		489-037-L10	109-019E		
ST1-109S078UL	109S078UL	200 V		489-037-L10	109-019E		
ST1-109S072UL	109S072UL	230 V		489-037-L10	109-019E		
ST1-109S005	109S005	100 V		489-006-L10	109-019E		
ST1-109S005UL	109S005UL		489-037-L10	109-019E			
ST1-109S024	109S024	120 V		489-006-L10	109-019E		
ST1-109S024UL	109S024UL	115 V		489-037-L10	109-019E		
ST1-109S008	109S008	200 V		489-006-L10	109-019E		
ST1-109S008UL	109S008UL		489-037-L10	109-019E			
ST1-109S025	109S025	230 V		489-006-L10	109-019E		
ST1-109S025UL	109S025UL		489-037-L10	109-019E			
ST1-109S029UL	109S029UL	100 V		489-037-L10	109-019E		
ST1-109S013	109S013		489-006-L10	109-019E			
ST1-109S013UL	109S013UL		489-037-L10	109-019E			
ST1-109S006	109S006		489-006-L10	109-019E			
ST1-109S006UL	109S006UL	100 V 115 V		489-037-L10	109-019E		
ST1-109S010	109S010	200 V		489-006-L10	109-019E		
ST1-109S010UL	109S010UL	200 V 240 V		489-037-L10	109-019E		
ST1-109S405UL-20	109S405UL-20	100 V	○ (5 V)	489-037-L10	109-019E		
ST1-109S405UL-30	109S405UL-30		○ (12 V)	489-037-L10	109-019E		
ST1-109S424UL-20	109S424UL-20	115 V	○ (5 V)	489-037-L10	109-019E		
ST1-109S424UL-30	109S424UL-30		○ (12 V)	489-037-L10	109-019E		
ST1-109S408UL-20	109S408UL-20	200 V	○ (5 V)	489-037-L10	109-019E		
ST1-109S408UL-30	109S408UL-30		○ (12 V)	489-037-L10	109-019E		
ST1-109S425UL-20	109S425UL-20	230 V	○ (5 V)	489-037-L10	109-019E		
ST1-109S425UL-30	109S425UL-30		○ (12 V)	489-037-L10	109-019E		
ST1-109S429UL-20	109S429UL-20	100 V	○ (5 V)	489-037-L10	109-019E		
ST1-109S429UL-30	109S429UL-30		○ (12 V)	489-037-L10	109-019E		
ST1-109S406UL-20	109S406UL-20	100 V	○ (5 V)	489-037-L10	109-019E		
ST1-109S406UL-30	109S406UL-30		○ (12 V)	489-037-L10	109-019E		
ST1-109S475UL-20	109S475UL-20	100 V	○ (5 V)	489-037-L10	109-019E		
ST1-109S475UL-30	109S475UL-30		○ (12 V)	489-037-L10	109-019E		
ST1-109S474UL-20	109S474UL-20	115 V	○ (5 V)	489-037-L10	109-019E		
ST1-109S474UL-30	109S474UL-30		○ (12 V)	489-037-L10	109-019E		
ST1-109S478UL-20	109S478UL-20	200 V	○ (5 V)	489-037-L10	109-019E		
ST1-109S478UL-30	109S478UL-30		○ (12 V)	489-037-L10	109-019E		
ST1-109S472UL-20	109S472UL-20	230 V	○ (5 V)	489-037-L10	109-019E		
ST1-109S472UL-30	109S472UL-30		○ (12 V)	489-037-L10	109-019E		

* PSE compatible.

Airflow - Static Pressure Characteristics

Standard

109S075UL, 109S074UL, 109S078UL, 109S072UL

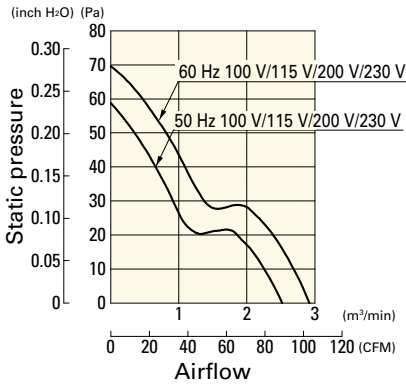

109S005, 109S005UL, 109S024, 109S024UL, 109S008, 109S008UL, 109S025, 109S025UL

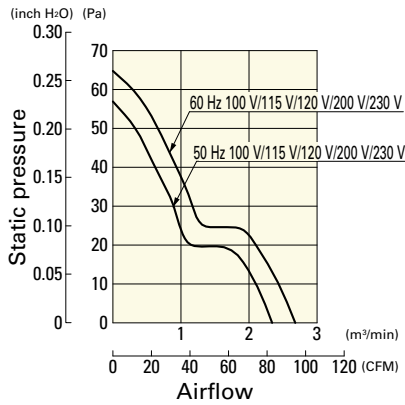

109S029UL

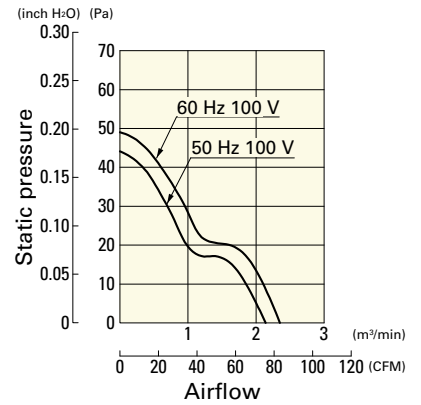

109S013, 109S013UL

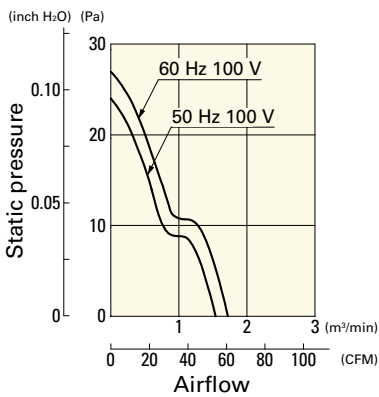

109S006, 109S006UL, 109S010, 109S010UL

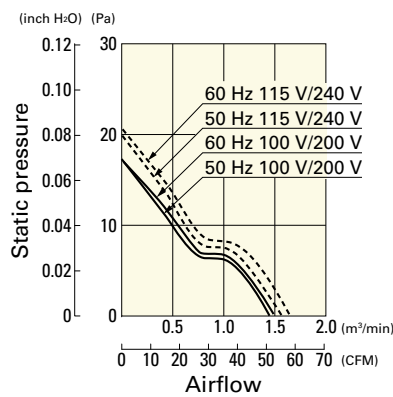

AC Fan 120 mm sq. AC

with Sensor

109S405UL, 109S424UL, 109S408UL, 109S425UL

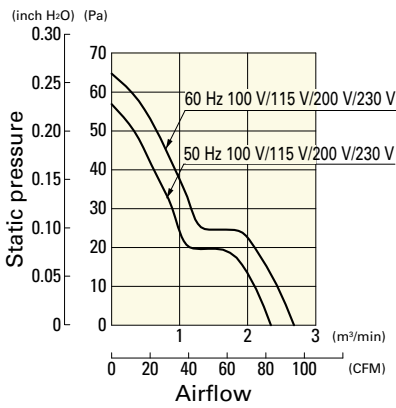

109S429UL

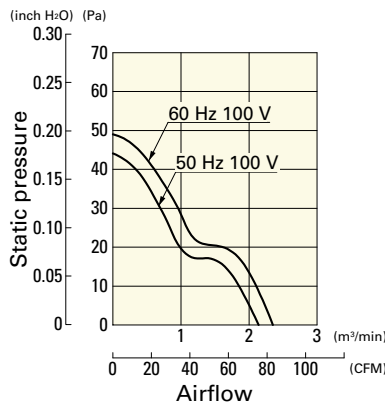

109S406UL

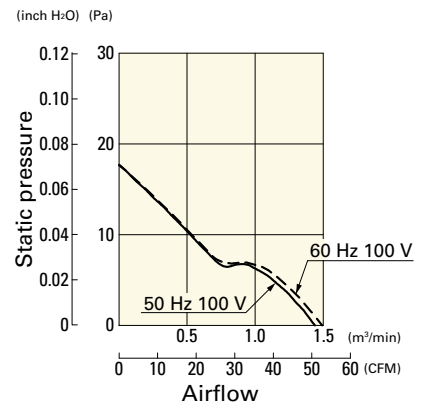

109S475UL, 109S474UL, 109S478UL, 109S472UL

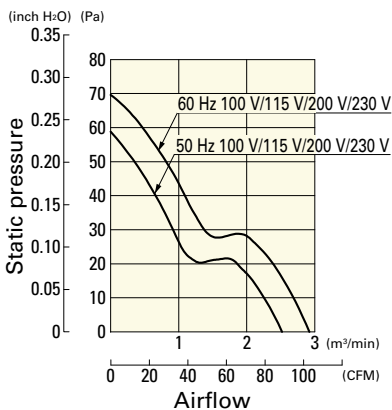

■ Dimensions (unit: mm)

Standard

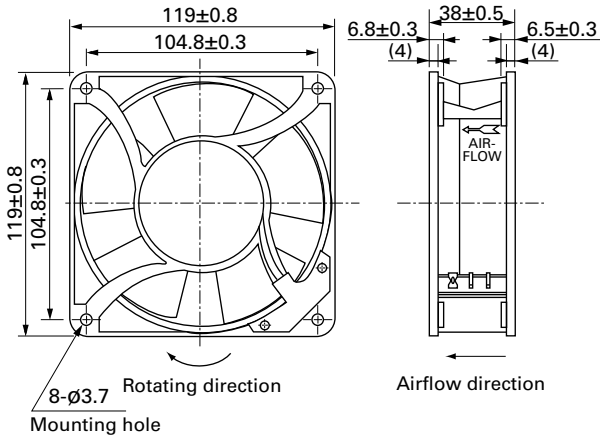

with Sensor When mounting the model with a sensor, please screw-mount through both flanges as it has a sensor box.

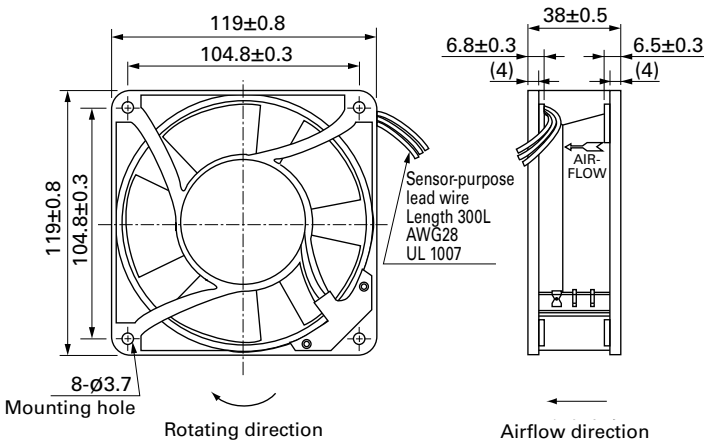

■ Reference Dimensions of Mounting Holes and Vent Opening (unit: mm)

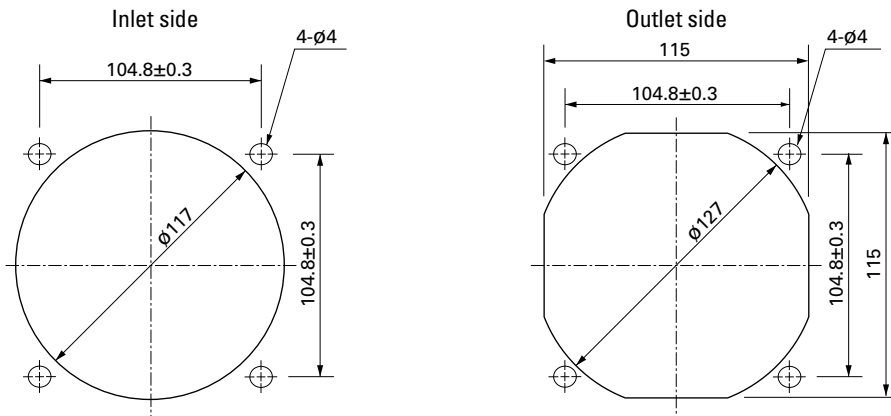

Wiring Diagram

Standard

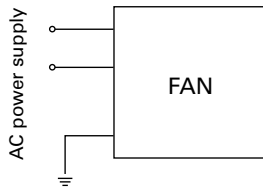

with Sensor

For fan power supply

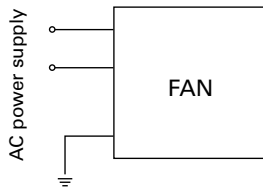

For sensor circuit
5 V (ITEM-20)

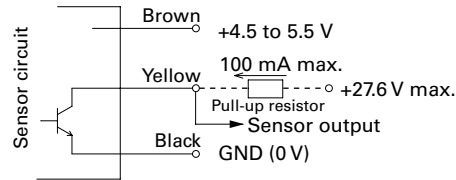

12 V (ITEM-30)

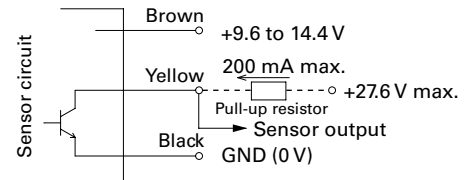

GND (Black) should be shared in case that power supply for sensor circuit (Brown) and that for sensor pull-up (Yellow) are separated.

Options

Finger guards

page: p. 585

Model no.: 109-019E, 109-019K, 109-019C, 109-019H

Resin finger guards

page: p. 591

Model no.: 109-1000G

Resin filter kits

page: p. 592

Model no.: 109-1000F13 (13PPI), 109-1000F20 (20PPI),
109-1000F30 (30PPI), 109-1000F40 (40PPI)

Filter kits

page: p. 593

Model no.: 109-018

Screen kits

page: p. 593

Model no.: 109-020

Plug cord

page: pp. 594 to 595

Exclusive for fans without UL at the end of the model number.

Model no.: 489-006-L10, 489-006-L21, 489-006-L35

Exclusive for fans with UL at the end of the model number.

Model no.: 489-037-L10, 489-037-L21, 489-037-L35,
489-007-L10, 489-007-L21



160×160×51 mm

San Ace 160 Only standard fans (without sensors) have acquired CSA certification.

General Specifications

- Material Frame: Aluminum, Impeller: Plastic (Flammability: UL 94V-1)
- Expected life See the table below. (L10 life: 90% survival rate for continuous operation in free air at 60°C, rated voltage) Expected life at 40°C is for reference only.
- Motor structure Capacitor motor
- Motor protection function Locked rotor burnout protection, Reverse polarity protection
For details, please refer to p. 599.
- Dielectric strength 50/60 Hz, 1500 VAC, for 1 minute (between input terminal and frame)
- Dielectric strength (with sensor) 50/60 Hz 1500 VAC 1 minute (between AC input terminal and frame)
50/60 Hz 1000 VAC 1 minute (between lead wire conductors and frame)
- Insulation resistance 10 MΩ or more with a 500 VDC megger
- Sound pressure level (SPL) At 1 m away from the air inlet
- Operating voltage range Voltage of each model ±10%
- Storage temperature -30 to +70°C (Non-condensing)
- Sensor-Purpose lead wire ⊕Brown ⊖Black (Sensor) Yellow
- Mass 1100 g

Specifications

Standard

Model no.	Rated voltage [V]	Frequency [Hz]	Input [W]	Current [A]	Locked rotor current [A]	Rated speed [min ⁻¹]	Max. airflow [m ³ /min] [CFM]	Max. static pressure [Pa] [inchH ₂ O]	SPL [dB (A)]	Operating temperature [°C]	Expected life [h]
109-601	100	50/60	37.5/33	0.43/0.35	0.72/0.7	2850/3350	7.2/8.5 254.4/300.4	156.8/166.6 0.63/0.669	56/60	-30 to +60	25000/60°C (56000/40°C)
109-604	115			0.39/0.31	0.62/0.61						
109-602	200			0.23/0.18	0.36/0.35						
109-603	230			0.21/0.16	0.32/0.31						

with Sensor

For sensor specifications, please refer to p. 602. Sensor specification differs depending on the fan's speed specification.

For a 5 V sensor power supply (ITEM-20), please append "-20" to the end of model number. E.g. 109-641-20

For a 12 V sensor power supply (ITEM-30), please append "-30" to the end of model number. E.g. 109-641-30

Model no.	Rated voltage [V]	Frequency [Hz]	Input [W]	Current [A]	Locked rotor current [A]	Rated speed [min ⁻¹]	Max. airflow [m ³ /min] [CFM]	Max. static pressure [Pa] [inchH ₂ O]	SPL [dB (A)]	Operating temperature [°C]	Expected life [h]
109-641	100	50/60	37.5/33	0.43/0.35	0.72/0.7	2850/3350	7.2/8.5 254.4/300.4	156.8/166.6 0.63/0.669	56/60	-10 to +60	25000/60°C (56000/40°C)
109-644	115			0.39/0.31	0.62/0.61						
109-642	200			0.23/0.18	0.36/0.35						
109-643	230			0.21/0.16	0.32/0.31						

Note: These are Short Lead Time Service applicable models. Contact your point of sale for stock availability. For more information on the service, see p. 654.

Set Models

Fan, finger guard, plug cord, screws, etc. can be purchased in one package. For details, please refer to p. 655.

Order no.	Set items					
	Fan	Voltage	Low-speed sensor	Plug cord*	Finger guards	Mounting screws
ST1-109-601	109-601	100 V		489-1618-L10	109-619E	M5×20 mm (4 screws)
ST1-109-604	109-604	115 V		489-1618-L10	109-619E	
ST1-109-602	109-602	200 V		489-1618-L10	109-619E	
ST1-109-603	109-603	230 V		489-1618-L10	109-619E	
ST1-109-641-20	109-641-20	100 V	○ (5 V)	489-1618-L10	109-619E	
ST1-109-641-30	109-641-30		○ (12 V)	489-1618-L10	109-619E	
ST1-109-644-20	109-644-20	115 V	○ (5 V)	489-1618-L10	109-619E	
ST1-109-644-30	109-644-30		○ (12 V)	489-1618-L10	109-619E	
ST1-109-642-20	109-642-20	200 V	○ (5 V)	489-1618-L10	109-619E	
ST1-109-642-30	109-642-30		○ (12 V)	489-1618-L10	109-619E	
ST1-109-643-20	109-643-20	230 V	○ (5 V)	489-1618-L10	109-619E	
ST1-109-643-30	109-643-30		○ (12 V)	489-1618-L10	109-619E	

* PSE compatible.

Airflow - Static Pressure Characteristics

Standard

109-601, 109-604, 109-602, 109-603

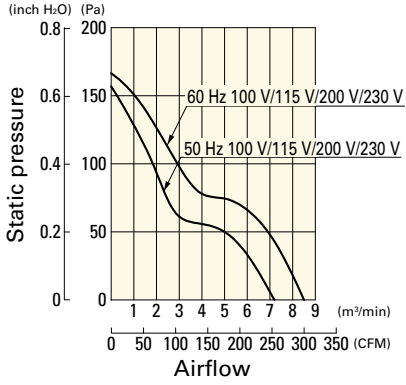

with Sensor

109-641, 109-644, 109-642, 109-643

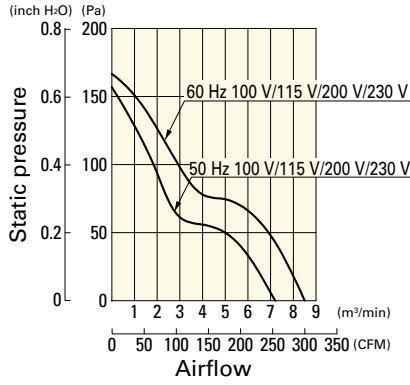

Dimensions (unit: mm)

Standard

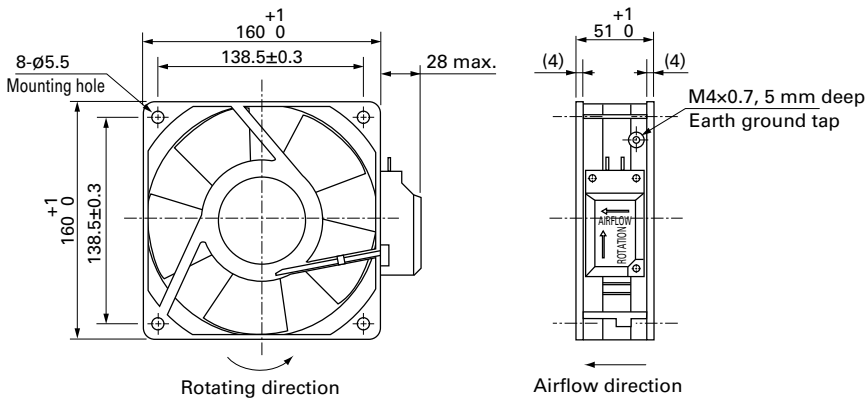

with Sensor

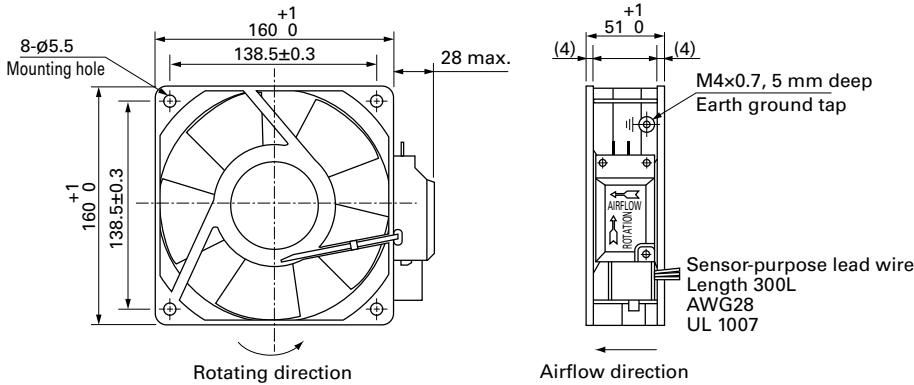

AC Fan 160 mm sq.

Reference Dimensions of Mounting Holes and Vent Opening (unit: mm)

Inlet side, Outlet side

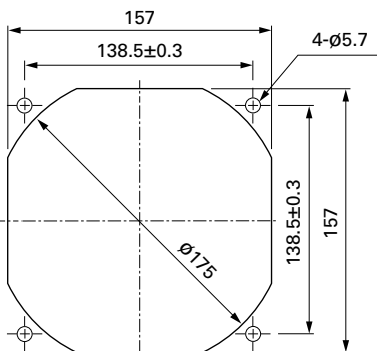

Wiring Diagram

Standard

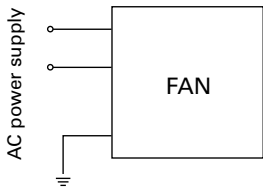

with Sensor

For fan power supply

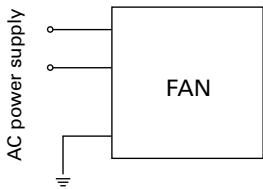

For sensor circuit
5 V (ITEM-20)

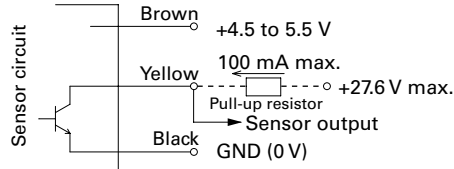

12 V (ITEM-30)

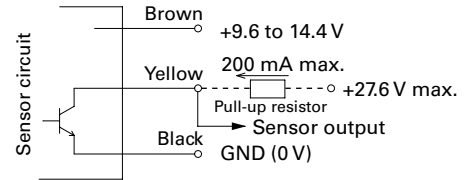

GND (Black) should be shared in case that power supply for sensor circuit (Brown) and that for sensor pull-up (Yellow) are separated.

Options

Finger guards

page: p. 585

Model no.: 109-619E, 109-619H, 109-620

Plug cord

page: pp. 594 to 595

Model no.: 489-084-L10, 489-084-L21, 489-086-L10,
489-086-L21, 489-1618-L10, 489-1618-L21,
489-1618-L28, 489-1619-L10, 489-1619-L21



∅ 172×150×51 mm

San Ace 172     

Sidecut type

General Specifications

- Material Frame: Aluminum, Impeller: Plastic (Flammability: UL 94V-1)
- Expected life See the table below. (L10 life: 90% survival rate for continuous operation in free air at 60°C, rated voltage) Expected life at 40°C is for reference only.
- Motor structure Capacitor motor
- Motor protection function Locked rotor burnout protection, Reverse polarity protection
For details, please refer to p. 599.
- Dielectric strength 50/60 Hz, 1500 VAC, for 1 minute (between input terminal and frame)
- Insulation resistance 10 MΩ or more with a 500 VDC megger
- Sound pressure level (SPL) At 1 m away from the air inlet
- Operating voltage range Voltage of each model ±10%
- Storage temperature -30 to +70°C (Non-condensing)
- Mass 1000 g

Specifications

Model no.	Rated voltage [V]	Frequency [Hz]	Input [W]	Current [A]	Locked rotor current [A]	Rated speed [min ⁻¹]	Max. airflow [m ³ /min] [CFM]	Max. static pressure [Pa] [inchH ₂ O]	SPL [dB (A)]	Operating temperature [°C]	Expected life [h]
109S301	100	50/60	27/25	0.33/0.25	0.65/0.64	2900/3500	5.3/6.4 187.3/226.1	147/196 0.59/0.787	51/56	-30 to +60	25000/60°C (56000/40°C)
109S304	115			0.29/0.22	0.55/0.54						
109S302	200			0.16/0.13	0.33/0.32						
109S303	230			0.14/0.11	0.28/0.27						

Note: These are Short Lead Time Service applicable models. Contact your point of sale for stock availability. For more information on the service, see p. 654.

Set Models

Fan, finger guard, plug cord, screws, etc. can be purchased in one package. For details, please refer to p. 655.

Order no.	Set items					
	Fan	Voltage	Low-speed sensor	Plug cord ⁽¹⁾	Finger guards	Mounting screws
ST1-109S301	109S301	100 V		489-1619-L10	109-319E	M4×25 mm (4 screws) ⁽²⁾
ST1-109S304	109S304	115 V		489-1619-L10	109-319E	
ST1-109S302	109S302	200 V		489-1619-L10	109-319E	
ST1-109S303	109S303	230 V		489-1619-L10	109-319E	

(1) PSE compatible.

(2) Though these are 2-hole or 3-hole frame mount types, 4 screws are included for extra.

Airflow - Static Pressure Characteristics

109S301, 109S304, 109S302, 109S303

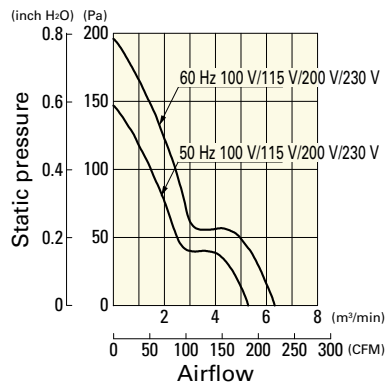

Dimensions (unit: mm)

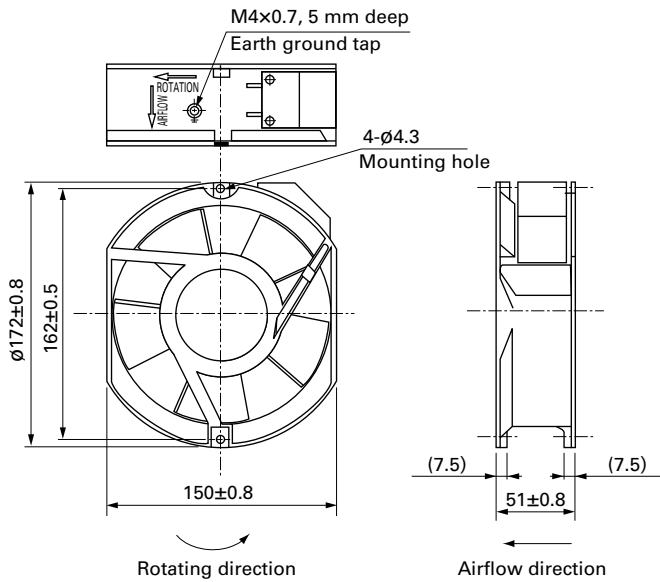

Reference Dimensions of Mounting Holes and Vent Opening (unit: mm)

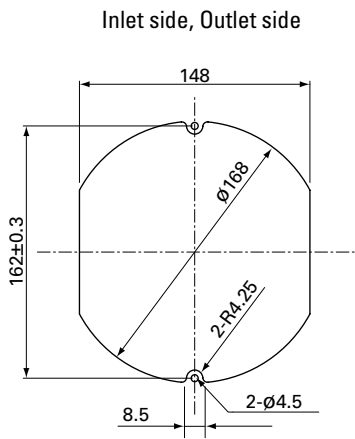

Wiring Diagram

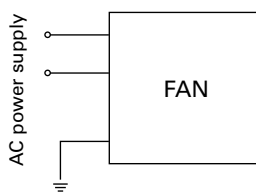

Options

Finger guards

page: p. 586





Model no.: 109-319E, 109-319H, 109-320

Plug cord

page: pp. 594 to 595

Model no.: 489-1619-L10, 489-1619-L21, 489-084-L10, 489-084-L21

∅172x51 mm

San Ace 172      Only standard fans (without sensors) have acquired CSA certification. Round type

General Specifications

- Material Frame: Aluminum, Impeller: Plastic (Flammability: UL 94V-1)
- Expected life See the table below. (L10 life: 90% survival rate for continuous operation in free air at 60°C, rated voltage)
Expected life at 40°C is for reference only.
- Motor structure Capacitor motor
- Motor protection function Locked rotor burnout protection, Reverse polarity protection
For details, please refer to p. 599.
- Dielectric strength 50/60 Hz, 1500 VAC, for 1 minute (between input terminal and frame)
- Dielectric strength (with sensor) 50/60 Hz 1500 VAC 1 minute (between AC input terminal and frame)
50/60 Hz 1000 VAC 1 minute (between lead wire conductors and frame)
- Insulation resistance 10 MΩ or more with a 500 VDC megger
- Sound pressure level (SPL) At 1 m away from the air inlet
- Operating voltage range Voltage of each model ±10%
- Storage temperature -30 to +70°C (Non-condensing)
- Sensor-Purpose lead wire ⊕Brown ⊖Black (Sensor) Yellow
- Mass 1000 g

Specifications

Standard

Model no.	Rated voltage [V]	Frequency [Hz]	Input [W]	Current [A]	Locked rotor current [A]	Rated speed [min ⁻¹]	Max. airflow [m ³ /min] [CFM]	Max. static pressure [Pa] [inchH ₂ O]	SPL [dB (A)]	Operating temperature [°C]	Expected life [h]
109-311	100	50/60	27/25	0.33/0.25	0.65/0.64	2900/3500	5.3/6.4 187.3/226.1	147/196 0.59/0.787	47/51	-30 to +60	25000/60°C (56000/40°C)
109-314	115			0.29/0.22	0.55/0.54						
109-312	200			0.16/0.13	0.33/0.32						
109-313	230			0.14/0.11	0.28/0.27						

with Sensor

For sensor specifications, please refer to p. 602. Sensor specification differs depending on the fan's speed specification.

For a 5 V sensor power supply (ITEM-20), please append "-20" to the end of model number. E.g. 109-371-20

For a 12 V sensor power supply (ITEM-30), please append "-30" to the end of model number. E.g. 109-371-30

Model no.	Rated voltage [V]	Frequency [Hz]	Input [W]	Current [A]	Locked rotor current [A]	Rated speed [min ⁻¹]	Max. airflow [m ³ /min] [CFM]	Max. static pressure [Pa] [inchH ₂ O]	SPL [dB (A)]	Operating temperature [°C]	Expected life [h]
109-371	100	50/60	27/25	0.33/0.25	0.65/0.64	2900/3500	5.3/6.4 187.3/226.1	147/196 0.59/0.787	47/51	-10 to +60	25000/60°C (56000/40°C)
109-374	115			0.29/0.22	0.55/0.54						
109-372	200			0.16/0.13	0.33/0.32						
109-373	230			0.14/0.11	0.28/0.27						

Note: These are Short Lead Time Service applicable models. Contact your point of sale for stock availability. For more information on the service, see p. 654.

Set Models

Fan, finger guard, plug cord, screws, etc. can be purchased in one package. For details, please refer to p. 655.

Order no.	Set items					
	Fan	Voltage	Low-speed sensor	Plug cord*	Finger guards	Mounting screws
ST1-109-311	109-311	100 V		489-1619-L10	109-319E	M4x25 mm (4 screws)
ST1-109-314	109-314	115 V		489-1619-L10	109-319E	
ST1-109-312	109-312	200 V		489-1619-L10	109-319E	
ST1-109-313	109-313	230 V		489-1619-L10	109-319E	
ST1-109-371-20	109-371-20	100 V	○ (5 V)	489-1619-L10	109-319E	
ST1-109-371-30	109-371-30		○ (12 V)	489-1619-L10	109-319E	
ST1-109-374-20	109-374-20	115 V	○ (5 V)	489-1619-L10	109-319E	
ST1-109-374-30	109-374-30		○ (12 V)	489-1619-L10	109-319E	
ST1-109-372-20	109-372-20	200 V	○ (5 V)	489-1619-L10	109-319E	
ST1-109-372-30	109-372-30		○ (12 V)	489-1619-L10	109-319E	
ST1-109-373-20	109-373-20	230 V	○ (5 V)	489-1619-L10	109-319E	
ST1-109-373-30	109-373-30		○ (12 V)	489-1619-L10	109-319E	

* PSE compatible.

Airflow - Static Pressure Characteristics

Standard

109-311, 109-314, 109-312, 109-313

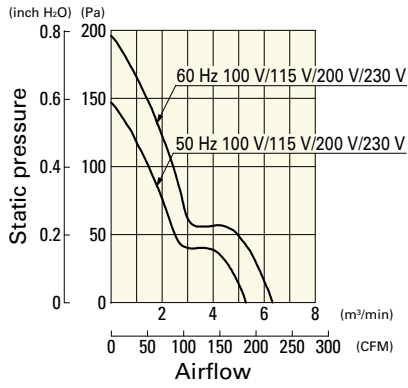

with Sensor

109-371, 109-374, 109-372, 109-373

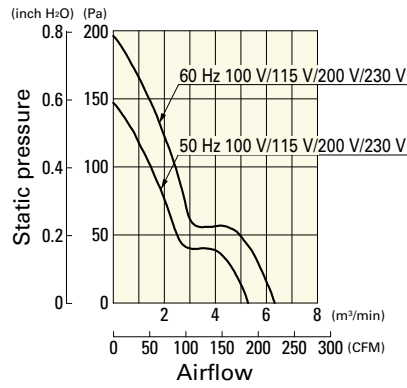

Dimensions (unit: mm)

Standard

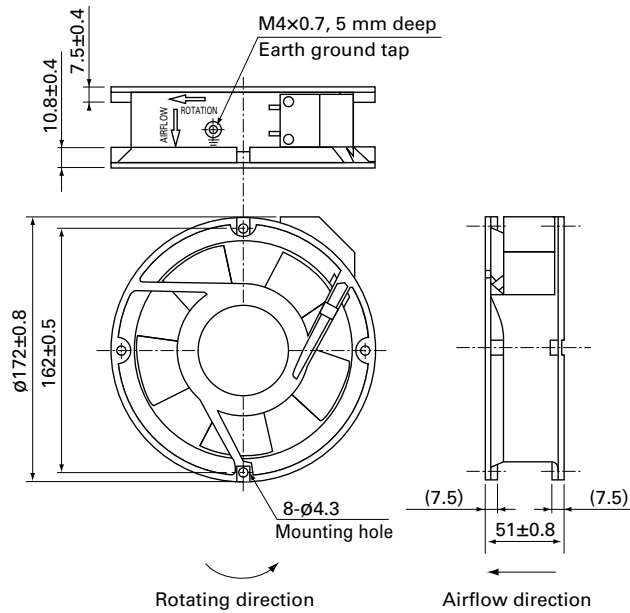

with Sensor

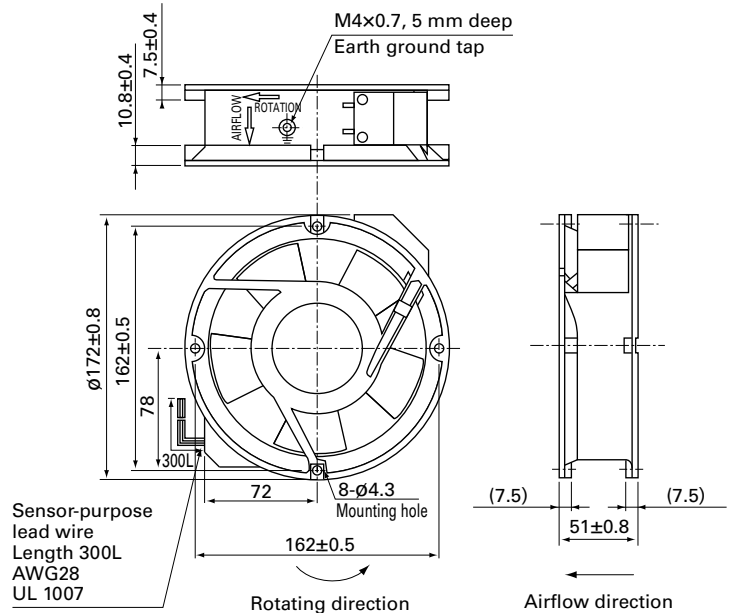

Reference Dimensions of Mounting Holes and Vent Opening (unit: mm)

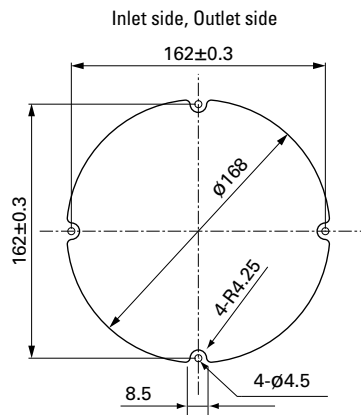

AC Fan \varnothing 172 mm AC

Wiring Diagram

Standard

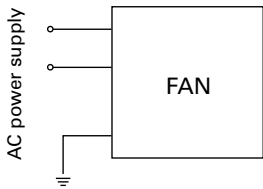

with Sensor

For fan power supply

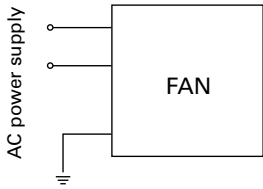

For sensor circuit
5 V (ITEM-20)

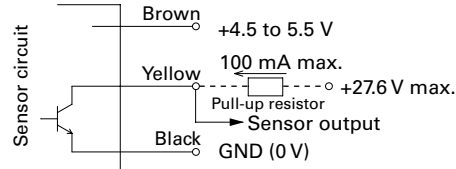

12 V (ITEM-30)

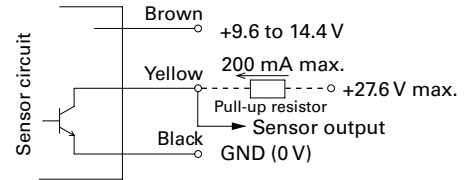

GND (Black) should be shared in case that power supply for sensor circuit (Brown) and that for sensor pull-up (Yellow) are separated.

Options

Finger guards

page: p. 586

Model no.: 109-319E, 109-319H, 109-320, 109-1066,
109-1068

Plug cord

page: pp. 594 to 595

Model no.: 489-1619-L10, 489-1619-L21, 489-084-L10,
489-084-L21

AC

AC Fan \varnothing 172 mm

Finger guards List

Increases safety by preventing foreign objects from entering fans. Fans can be used with little effect on airflow and static pressure.

Size	Model no.	Mounting side	Surface treatment	
			Nickel-chrome plating (silver)	Cation electropainting (black)
36 mm sq. type	109-1050	Inlet side, Outlet side	✓	–
38 mm sq. type	109-1065	Inlet side, Outlet side	✓	–
40 mm sq. type	109-059	Inlet side, Outlet side	✓	–
	109-059H		–	✓
52 mm sq. type	109-149E	Inlet side, Outlet side	✓	–
	109-149	Outlet side	✓	–
60 mm sq. type	109-139E	Inlet side, Outlet side	✓	–
	109-139H		–	✓
70 mm sq. type, \varnothing70 mm type	109-1128	Inlet side, Outlet side	✓	–
80 mm sq. type	109-049E	Inlet side, Outlet side	✓	–
	109-049H		–	✓
	109-049C	Outlet side	✓	–
92 mm sq. type	109-099C	Outlet side	✓	–
\varnothing92 mm type	109-1147	Impeller side, Nameplate side	✓	–
92 mm sq. type, \varnothing100 mm type	109-099E	Inlet side, Outlet side	✓	–
	109-099H		–	✓
120 mm sq. type	109-019E	Inlet side, Outlet side	✓	–
	109-019K		–	✓
	109-019C	Outlet side	✓	–
	109-019H		–	✓
127 mm sq. type, \varnothing175 mm type	109-722	Inlet side, Outlet side	✓	–
	109-722H	Inlet side, Outlet side	–	✓
127 mm sq. type	109-723	Outlet side	✓	–
\varnothing133 mm type	109-1112	Inlet side	✓	–
\varnothing136 mm type	109-1139	Impeller side, Nameplate side	✓	–
140 mm sq. type	109-719	Inlet side, Outlet side	✓	–
	109-719H		–	✓
150 mm sq. type	109-1051	Inlet side, Outlet side	✓	–
	109-1052	Outlet side	✓	–
\varnothing150 mm type	109-1104	Inlet side	✓	–
	109-1104H		–	✓
160 mm sq. type	109-619E	Inlet side, Outlet side	✓	–
	109-619H		–	✓
	109-620	Outlet side	✓	–
\varnothing172 mm Sidecut type	109-319J	Inlet side, Outlet side	✓	–
\varnothing172 mm Sidecut, Round type	109-319E	Inlet side, Outlet side	✓	–
	109-319H		–	✓
	109-320	Outlet side	✓	–
\varnothing172 mm Round type	109-1066	Inlet side, Outlet side	✓	–
	109-1068	Outlet side	✓	–
\varnothing200 mm type	109-1102*	Inlet side, Outlet side	✓	–
	109-1102H*		–	✓
	109-1103*	Outlet side	✓	–
	109-1103H*		–	✓
	109-720	Inlet side, Outlet side	✓	–
	109-720H		–	✓
	109-721	Outlet side	✓	–
109-721H	–		✓	
\varnothing221 mm type	109-1138	Inlet side	✓	–
	109-1138H		–	✓
\varnothing225 mm type	109-1137	Inlet side	✓	–
	109-1137H		–	✓
270 mm sq. type (for Bracket-mounted Centrifugal Fan)	109-1146	Inlet side	✓	–
	109-1146H		–	✓

* Applicable model no.: 9GV20*

Finger guards Dimensions (unit: mm)

For use in environments subject to water splashes, cation electroplating models are recommended.

36 mm sq. type

Model no.	Surface treatment	Mass (g)
109-1050	Nickel-chrome plating (silver)	4

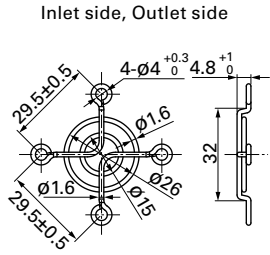

38 mm sq. type

Model no.	Surface treatment	Mass (g)
109-1065	Nickel-chrome plating (silver)	5

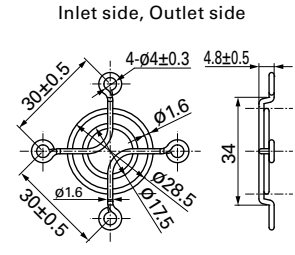

40 mm sq. type

Model no.	Surface treatment	Mass (g)
109-059	Nickel-chrome plating (silver)	7
109-059H	Cation electroplating (black)	

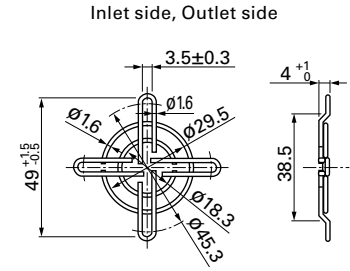

52 mm sq. type

Model no.	Surface treatment	Mass (g)
109-149E	Nickel-chrome plating (silver)	9

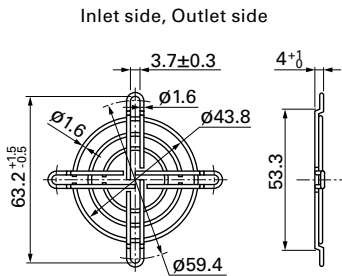

60 mm sq. type

Model no.	Surface treatment	Mass (g)
109-149	Nickel-chrome plating (silver)	7

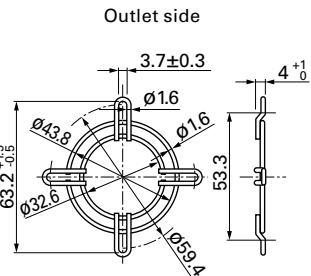

60 mm sq. type

Model no.	Surface treatment	Mass (g)
109-139E	Nickel-chrome plating (silver)	14.5
109-139H	Cation electroplating (black)	

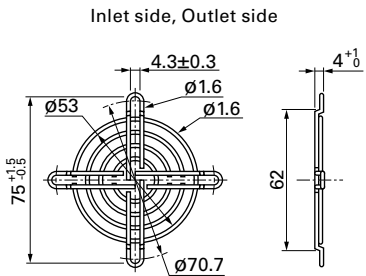

70 mm sq. type, ø70 mm type

Model no.	Surface treatment	Mass (g)
109-1128	Nickel-chrome plating (silver)	17

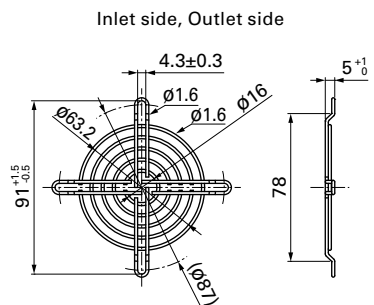

80 mm sq. type

Model no.	Surface treatment	Mass (g)
109-049E	Nickel-chrome plating (silver)	21
109-049H	Cation electroplating (black)	

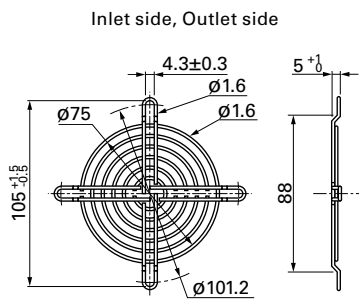

80 mm sq. type

Model no.	Surface treatment	Mass (g)
109-049C	Nickel-chrome plating (silver)	17

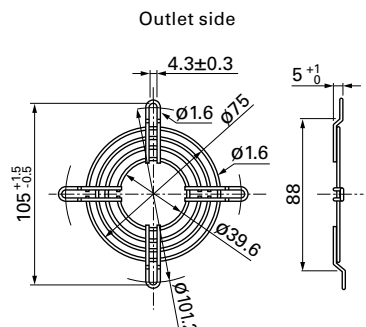

92 mm sq. type

Model no.	Surface treatment	Mass (g)
109-099C	Nickel-chrome plating (silver)	22

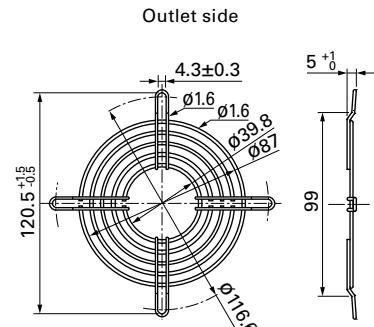

ø92 mm type

Model no.	Surface treatment	Mass (g)
109-1147	Nickel-chrome plating (silver)	23

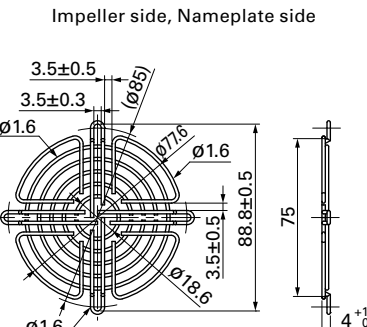

92 mm sq., ø100 mm type

Model no.	Surface treatment	Mass (g)
109-099E	Nickel-chrome plating (silver)	29
109-099H	Cation electroplating (black)	

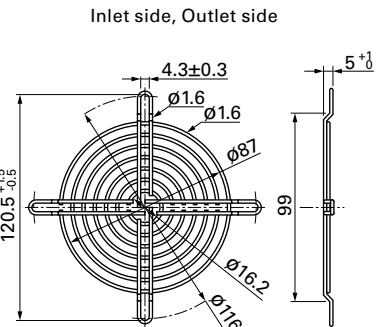

Option

Finger guards Dimensions (unit: mm)

For use in environments subject to water splashes, cation electroplating models are recommended.

120 mm sq. type

Model no.	Surface treatment	Mass (g)
109-019E	Nickel-chrome plating (silver)	42
109-019K	Cation electroplating (black)	

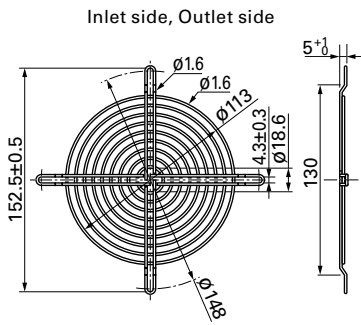

Model no.	Surface treatment	Mass (g)
109-019C	Nickel-chrome plating (silver)	32
109-019H	Cation electroplating (black)	

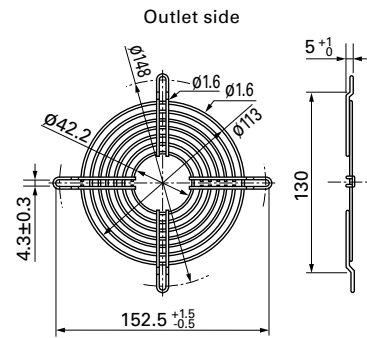

127 mm sq., Ø175 mm type

Model no.	Surface treatment	Mass (g)
109-722	Nickel-chrome plating (silver)	43
109-722H	Cation electroplating (black)	

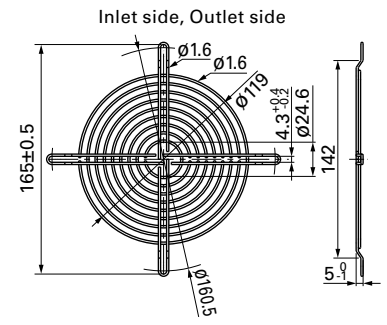

127 mm sq. type

Model no.	Surface treatment	Mass (g)
109-723	Nickel-chrome plating (silver)	34

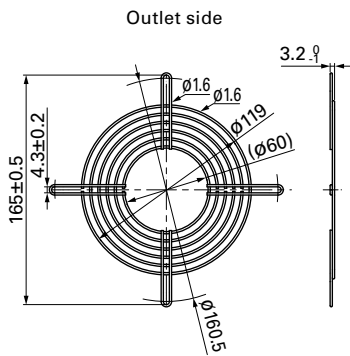

Ø133 mm type

Model no.	Surface treatment	Mass (g)
109-1112	Nickel-chrome plating (silver)	65

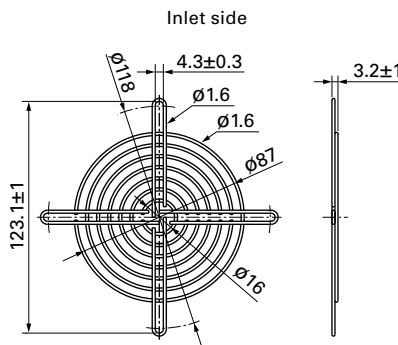

Ø136 mm type

Model no.	Surface treatment	Mass (g)
109-1139	Nickel-chrome plating (silver)	41

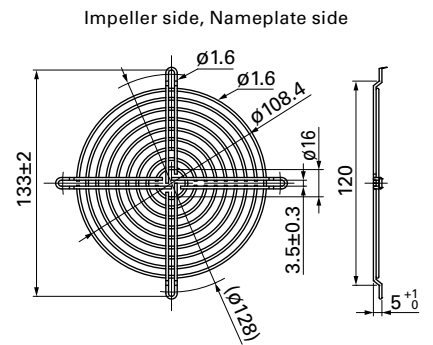

140 mm sq. type

Model no.	Surface treatment	Mass (g)
109-719	Nickel-chrome plating (silver)	51
109-719H	Cation electroplating (black)	

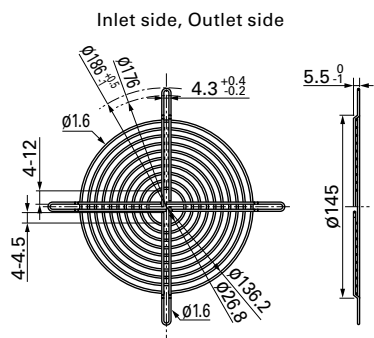

150 mm sq. type

Model no.	Surface treatment	Mass (g)
109-1051	Nickel-chrome plating (silver)	63

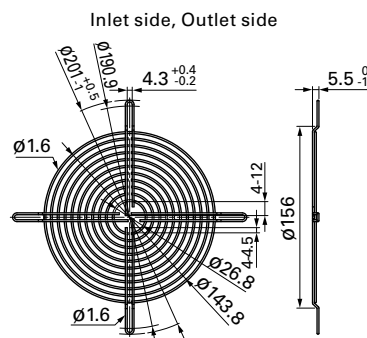

Model no.	Surface treatment	Mass (g)
109-1052	Nickel-chrome plating (silver)	53

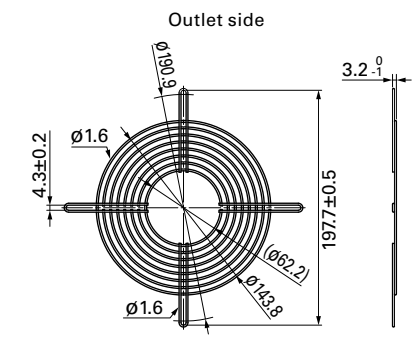

Ø150 mm type

Model no.	Surface treatment	Mass (g)
109-1104	Nickel-chrome plating (silver)	31
109-1104H	Cation electroplating (black)	

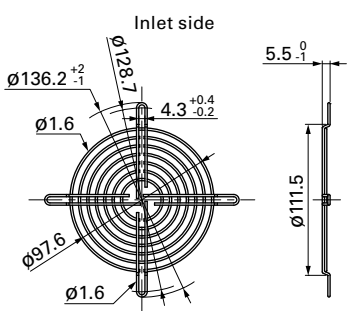

160 mm sq. type

Model no.	Surface treatment	Mass (g)
109-619E	Nickel-chrome plating (silver)	85
109-619H	Cation electroplating (black)	

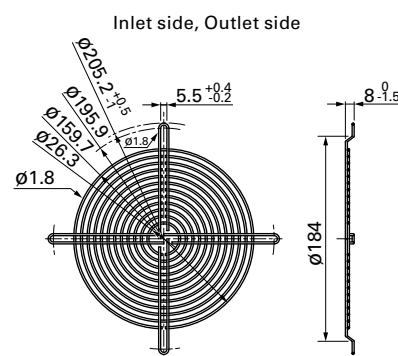

Model no.	Surface treatment	Mass (g)
109-620	Nickel-chrome plating (silver)	74

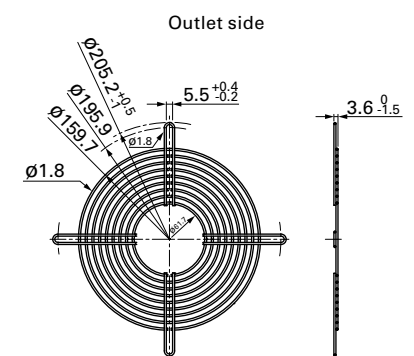

Option

Finger guards Dimensions (unit: mm)

For use in environments subject to water splashes, cation electroplating models are recommended.

Ø172 mm Sidecut type

Model no.	Surface treatment	Mass (g)	Applicable model no.
109-319J	Nickel-chrome plating (silver)	65	9HV57*/9SG57*/9GV57* 9CR57*/9WG57*

Finger guard 109-319J should be mounted with four holes as in the drawing.

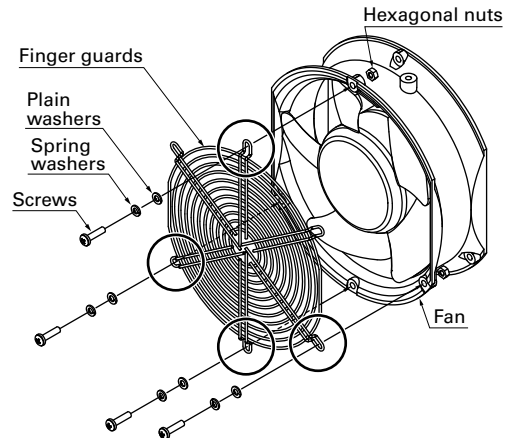
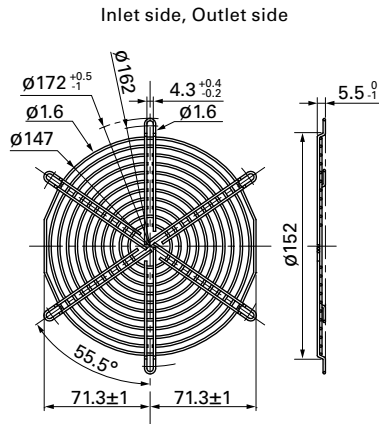

●No nuts or screws for use in attachment included.

Ø172 mm Sidecut, Round type

Model no.	Surface treatment	Mass (g)
109-319E	Nickel-chrome plating (silver)	69
109-319H	Cation electroplating (black)	

Model no.	Surface treatment	Mass (g)
109-320	Nickel-chrome plating (silver)	53

Finger guards 109-319E, 109-319H, and 109-320 should be mounted with two holes as in the drawing and do not use any other holes.

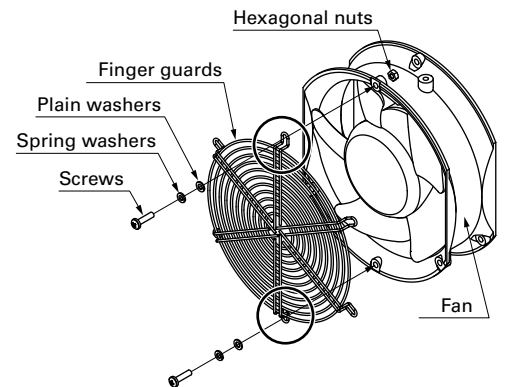
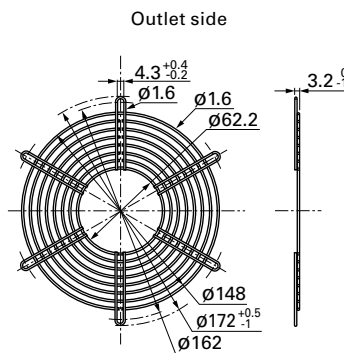
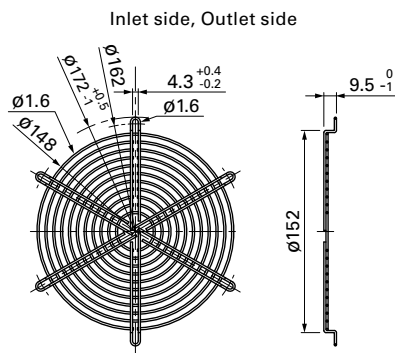

●No nuts or screws for use in attachment included.

Ø172 mm Round type

Model no.	Surface treatment	Mass (g)
109-1066	Nickel-chrome plating (silver)	61

Model no.	Surface treatment	Mass (g)
109-1068	Nickel-chrome plating (silver)	54

Inlet side, Outlet side

Outlet side

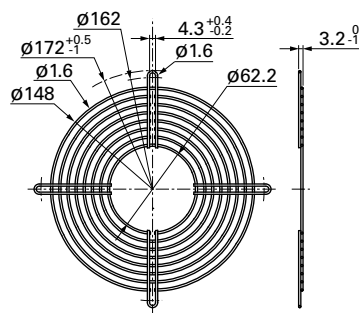
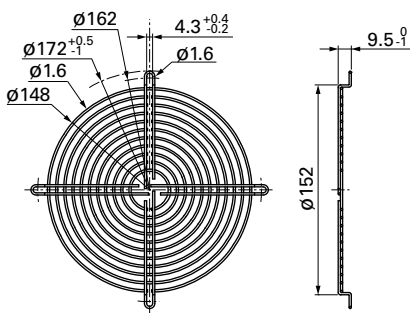

Option

Finger guards Dimensions (unit: mm)

For use in environments subject to water splashes, cation electroplating models are recommended.

270 mm sq. type (for Bracket-mounted Centrifugal Fan)

Model no.	Surface treatment	Mass (g)
109-1146	Nickel-chrome plating (silver)	106
109-1146H	Cation electropainting (black)	

Finger guard 109-1146 and 109-1146H should be mounted with four holes as in the drawing.

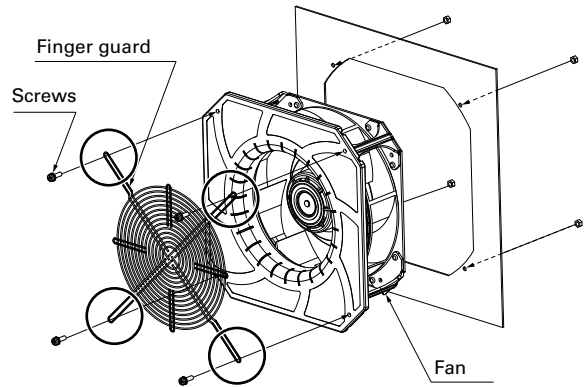
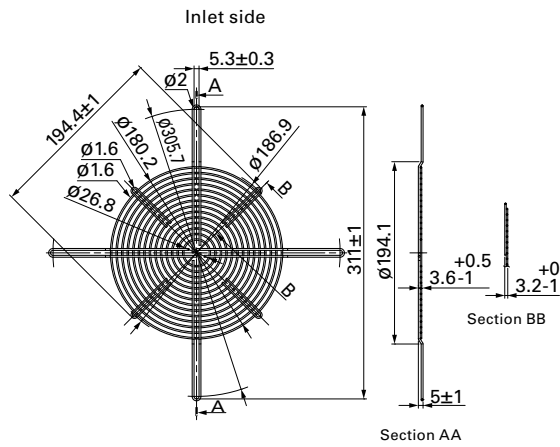

●No nuts or screws for use in attachment included.

Mounting example

Axial fan

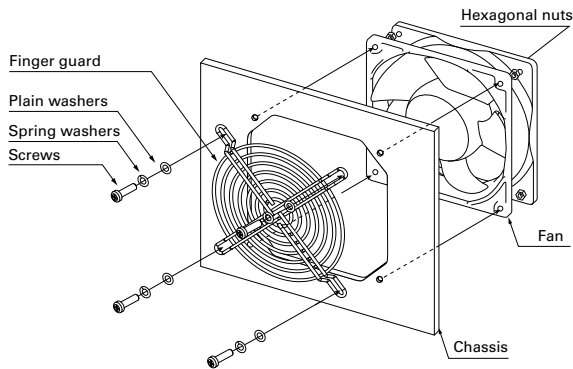

●No nuts or screws for use in attachment included.

Centrifugal fan

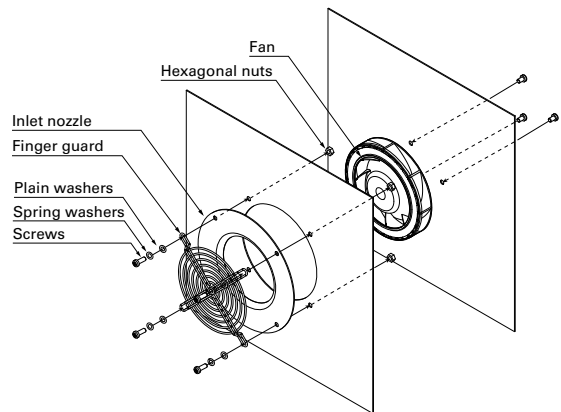

Inlet nozzle for centrifugal fan and splash proof centrifugal fan Dimensions (unit: mm)

Nozzle mounted in fan inlet side to adjust the flow of introduced air. Material: Steel sheet
 For use in environments subject to water splashes, cation electroplating models are recommended.

∅70 mm type

Model no.	Surface treatment	Mass (g)
109-1106	Electro nickel plating (silver)	40

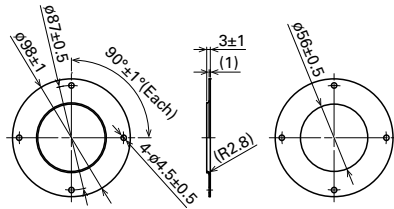

∅100 mm type

Model no.	Surface treatment	Mass (g)
109-1080	Electro nickel plating (silver)	80
109-1080H	Cation electroplating (black)	

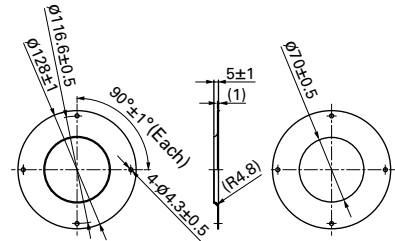

∅133 mm type

Model no.	Surface treatment	Mass (g)
109-1069	Electro nickel plating (silver)	76
109-1069H	Cation electroplating (black)	

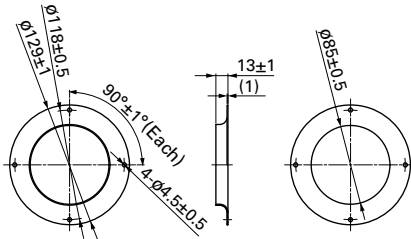

∅150 mm type

Model no.	Surface treatment	Mass (g)
109-1081	Electro nickel plating (silver)	70
109-1081H	Cation electroplating (black)	

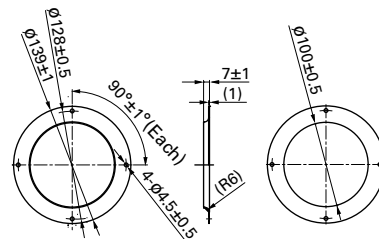

∅175 mm type

Model no.	Surface treatment	Mass (g)
109-1073	Electro nickel plating (silver)	100
109-1073H	Cation electroplating (black)	

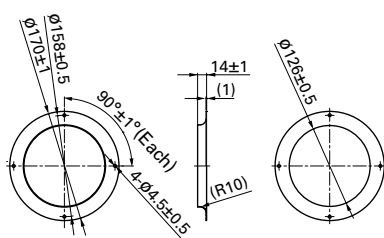

∅221 mm type

Model no.	Surface treatment	Mass (g)
109-1135	Electro nickel plating (silver)	230
109-1135H	Cation electroplating (black)	

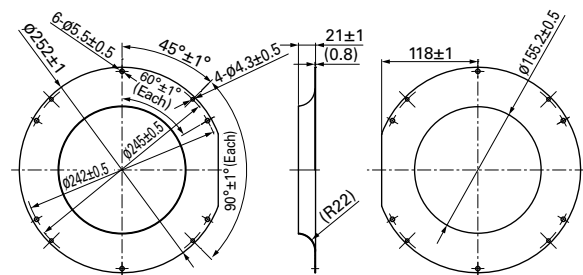

∅225 mm type

Model no.	Surface treatment	Mass (g)
109-1134	Electro nickel plating (silver)	360
109-1134H	Cation electroplating (black)	

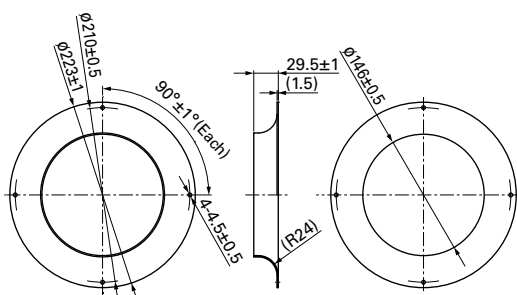

Option

EMC guards Dimensions (unit: mm)

It is a metallic piece that protects materials from the adverse effects of electromagnetic noise sources. It provides electromagnetic shielding. It is attached to the casing of a device by means of the fan fixing screw (s). Ground the devices equipped with an EMC guard. Rust may occur if used in wet environments. Please refer to page 606 for detail.

80 mm sq. type

Model no.	Surface treatment	Mass (g)
109-1038	Nickel-chrome plating (silver)	14

Representative fans model numbers	Dimensions of fans (mm)
109P08*	80×80×20
9GV08*	80×80×25
9GV08*	80×80×38
9HV08*	
9HVA08*	
9HVB08*	

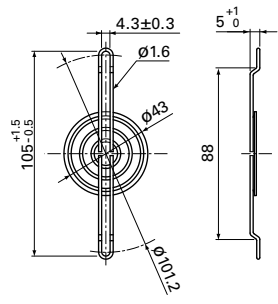

80 mm sq. type

Model no.	Surface treatment	Mass (g)
109-1039	Nickel-chrome plating (silver)	10

Representative fans model numbers	Dimensions of fans (mm)
109P08*	80×80×15
9GA08*	80×80×20
109R08*	80×80×25
9A08*	
9GA08*	
9GA08*	80×80×32
9G08*	80×80×38
9GA08*	

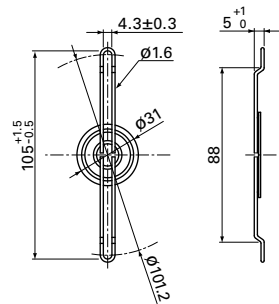

92 mm sq. type

Model no.	Surface treatment	Mass (g)
109-1040	Nickel-chrome plating (silver)	15

Representative fans model numbers	Dimensions of fans (mm)
9G09*	92×92×32
9G09*	92×92×38
9GV09*	
9GA09*	
9AD09*	

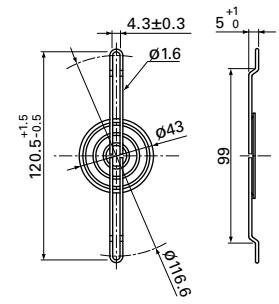

120 mm sq. type

Model no.	Surface treatment	Mass (g)
109-1037	Nickel-chrome plating (silver)	26

Representative fans model numbers	Dimensions of fans (mm)
9G12*	120×120×25
9GV12*	
9GL12*	120×120×38
9G12*	
9GV12*	
9HV12*	
9LG12*	
9AD12*	

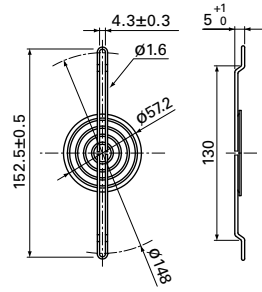

Ø172 mm type

Model no.	Surface treatment	Mass (g)
109-1036	Nickel-chrome plating (silver)	49

Representative fans model numbers	Dimensions of fans (mm)
109E47*	Ø172×25
109L17*	Ø172×51
9GV57*	
109E17*	
109E57*	
9SG57*	

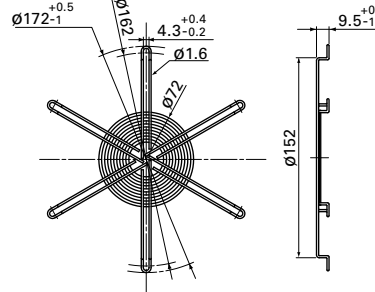

Option

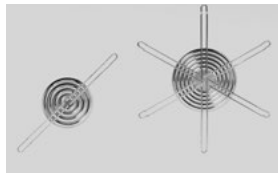

EMC guard

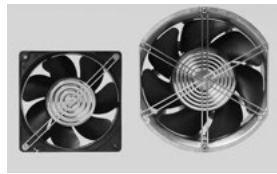

attached to a cooling fan

Resin finger guards Dimensions (unit: mm)

Material Frame: Resin (PPE+PS) UL file no. E82268 94V-0

60 mm sq. type

Model no.	Mass (g)
109-1003G	7

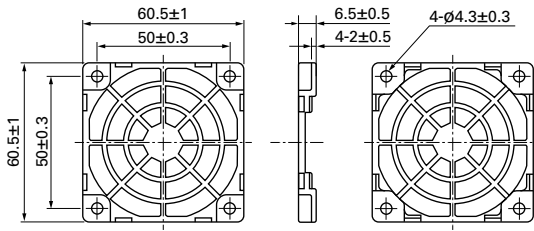

80 mm sq. type

Model no.	Mass (g)
109-1002G	10

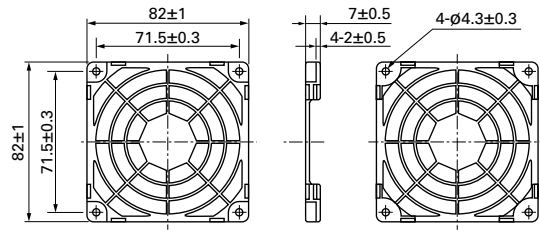

92 mm sq. type

Model no.	Mass (g)
109-1001G	12

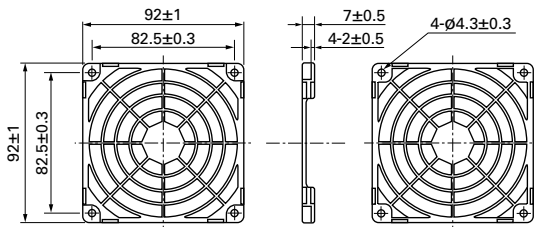

120 mm sq. type

Model no.	Mass (g)
109-1000G	23

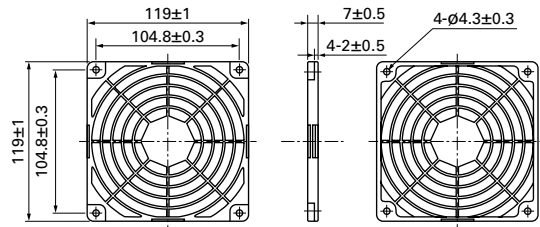

Airflow - Static pressure characteristics

Measured with our double chamber measuring device (120 mm sq. type)

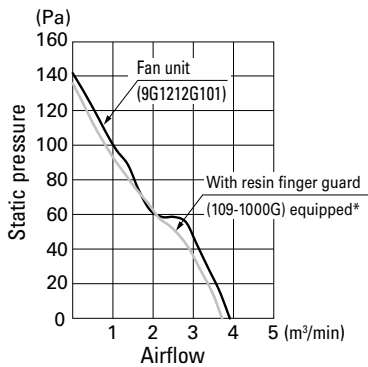

Applied voltage: 12 VDC

* Finger guard is attached on air inlet side of fan.

Mounting example

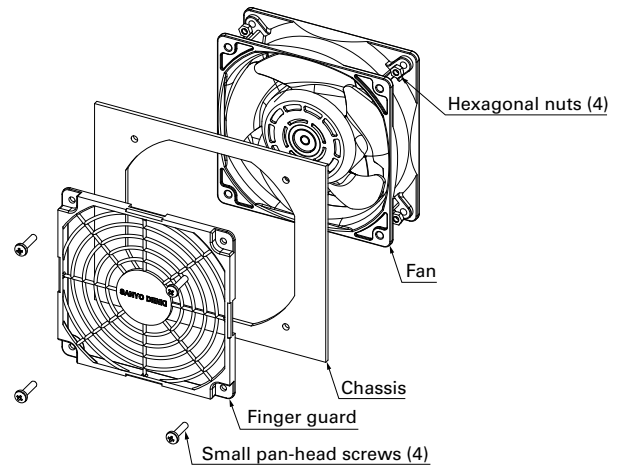

- Operating temperature limit is between -20 to +70°C. (non condensing)
- Plastic finger guards are placed on both the intake and exhaust sides of the fan.
- No nuts or screws for use in attachment included.

Option

Resin filter kits Dimensions (unit: mm)

Material Guard, cover: Resin (PPE+PS) UL file no. E82268 94V-0 Filter: Polyurethane foam UL file no. E74916 (S) 94HF-1
 PPI: Particles Per Inch Indicates the number of holes per inch. Note that the higher the number, the finer the grain of the sponge.

60 mm sq. type

Model no.	Mass (g)
109-1003F13 (13 PPI)	11
109-1003F20 (20 PPI)	
109-1003F30 (30 PPI)	
109-1003F40 (40 PPI)	
Replacement filter model no.	Quantity
109-1003M13 (13 PPI)	5
109-1003M20 (20 PPI)	
109-1003M30 (30 PPI)	
109-1003M40 (40 PPI)	

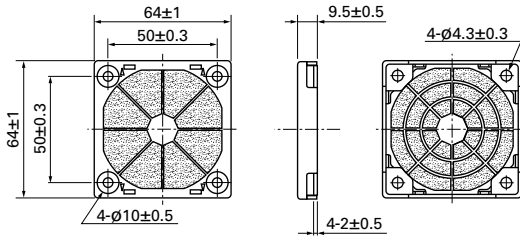

80 mm sq. type

Model no.	Mass (g)
109-1002F13 (13 PPI)	19
109-1002F20 (20 PPI)	
109-1002F30 (30 PPI)	
109-1002F40 (40 PPI)	
Replacement filter model no.	Quantity
109-1002M13 (13 PPI)	5
109-1002M20 (20 PPI)	
109-1002M30 (30 PPI)	
109-1002M40 (40 PPI)	

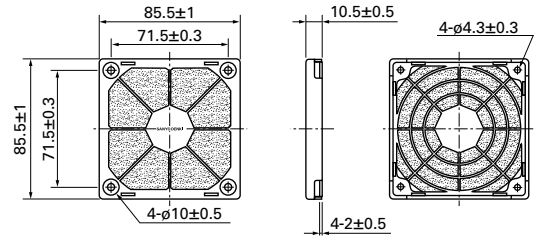

92 mm sq. type

Model no.	Mass (g)
109-1001F13 (13 PPI)	25
109-1001F20 (20 PPI)	
109-1001F30 (30 PPI)	
109-1001F40 (40 PPI)	
Replacement filter model no.	Quantity
109-1001M13 (13 PPI)	5
109-1001M20 (20 PPI)	
109-1001M30 (30 PPI)	
109-1001M40 (40 PPI)	

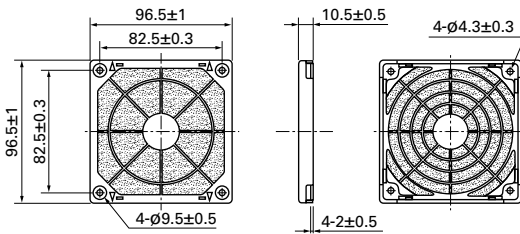

120 mm sq. type

Model no.	Mass (g)
109-1000F13 (13 PPI)	44
109-1000F20 (20 PPI)	
109-1000F30 (30 PPI)	
109-1000F40 (40 PPI)	
Replacement filter model no.	Quantity
109-1000M13 (13 PPI)	5
109-1000M20 (20 PPI)	
109-1000M30 (30 PPI)	
109-1000M40 (40 PPI)	

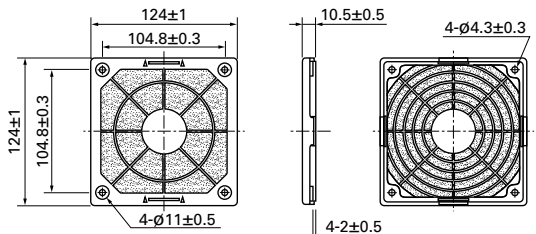

Airflow - Static pressure characteristics

Measured with our double chamber measuring device (120 mm sq. type)

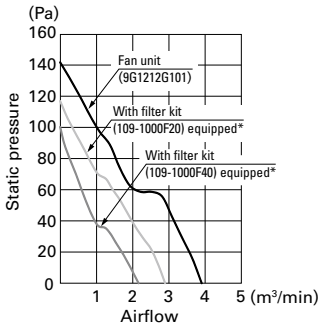

Applied voltage: 12 VDC

* Filter kit is attached on air inlet side of fan.

Mounting example

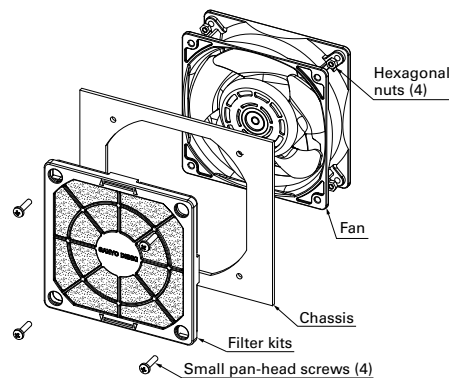

Filter replacement (example)

Replacement filters can be replaced by taking off the front part of the filter kit. There is no need to remove the screws.

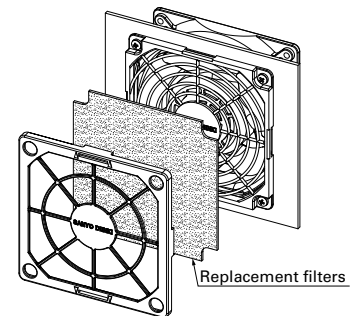

Option

- Filter kit is one of the option to keep air in the chassis clean filtering dust in external atmosphere when pulling-air cooling is implemented. The filter kit is hooked up through mounting hole of fan frame with screw as well as finger guard. Some performances (airflow & static pressure) of the fan motor decreases when filter kit is hooked up.
- This Filter Kit is composed of 3 components, including a guard, a filter and a cover. It is delivered as a finished product at delivery, saving assembly time when mounting. It can be mounted by inserting a screw in the apertures of the cover.
- The filter and cover can be easily removed from the guard with one touch. There is no need for fan removal when undertaking maintenance. ● Operating temperature limit is between -10 to +60°C. (non condensing)
- The filter will deteriorate with age, and the level of deterioration will vary upon usage conditions. Please be aware that the filter has a greater tendency to deteriorate under high temperature and humidity. For long-term storage, please store under the temperature range of 10 to 30°C, humidity range of 20 to 65%. Usage and storage period is approximately 2 years.
- Cooling ability decreases with filter contamination due to clogging. Filter replacement is recommended approximately every six months of usage. Please replace the filter if deterioration or clogging is seen at inspection.
- When replacing the filter, please use genuine SANYO DENKI filters. ● Do not water-wash the filter.
- Avoid use and storage under high temperature or humidity, direct sunlight or exposure to ultraviolet light, or in corrosive gas. ● No nuts or screws for use in attachment included.

Specifications for DC Fan Sensors

Pulse sensor (Tach output type) example

Pulse sensor outputs two pulse waves per revolution of fan, and it is good to detect fan speed. Pulse sensors can be incorporated in all kinds of DC fans.

Noise from inside the fan or from external devices may effect sensor output.

Contact us for more information.

The specifications listed below are for the 9G1212H101 model, and vary with the model number used. Please contact your point of sale for details.

Output circuit

Open collector

Specifications

$V_{CE} = +30\text{ V max.}$

(For a 48 V-rated fan: $V_{ce} = +60\text{ V max.}$)

$I_c = 10\text{ mA max.}$ [$V_{OL} = V_{ce}(\text{SAT}) = 0.4\text{ V or less}$]

Inside of DC fan

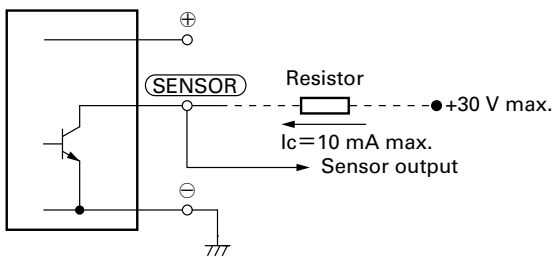

Output waveform (Need pull-up resistor)

In case of steady running

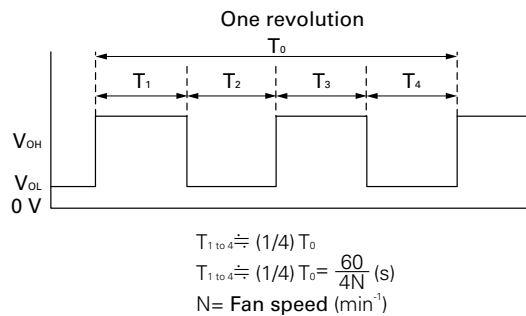

If you want detailed specifications that apply when the rotor is locked, please contact SANYO DENKI.

Locked rotor sensor (rotation / lock detection type) example

Locked rotor sensor outputs fan status signals. It is good to check whether the fan is running or locked

Noise from inside the fan or from external devices may effect sensor output.

Regarding details of the reverse logic and specifications of lock sensor output signals, please contact SANYO DENKI.

Lock sensor can not be used in some models. Contact us for more information.

The specifications listed below are for the 9G1212H1D01 model, and vary with the model number used. Please contact your point of sale for details.

Output circuit

Open collector

Specifications

$V_{CE} = +27.6\text{ V max.}$

For a 48 V fan $V_{CE} = +60\text{ V max.}$

$I_c = 5\text{ mA max.}$ [$V_{OL} = V_{ce}(\text{SAT}) = 0.6\text{ V or less}$]

For a 48 V fan: $V_{ce}(\text{SAT}) = 0.4\text{ V or less}$

Inside of DC fan

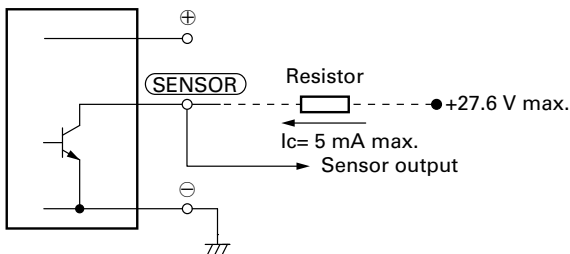

Output waveform (Need pull-up resistor)

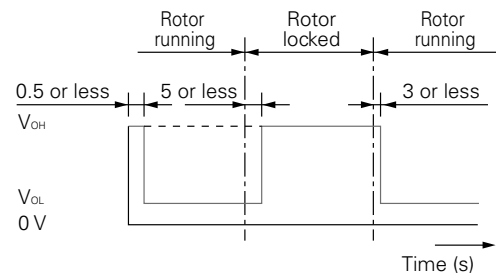

Note: The output is completely at V_{OL} with 0.5 s or less after power-up.

Low-speed sensor (rotating speed detection type) example

Low-speed sensor outputs a signal when fan speed goes down to trip point or less. It is good to detect cooling degradation of fan. Noise from inside the fan or from external devices may effect sensor output, please. If you want detailed specification and reverse signal output, please contact SANYO DENKI. Low-speed sensors can not be used in some models. Contact us for more information.

The specifications listed below are for the 9G1212H1H01 model, and vary with the model number used. Please contact your point of sale for details.

Output circuit

Open collector

Specifications

$V_{CE} = +27.6$ V max.
 $I_c = 10$ mA max. [$V_{OL} = V_{CE} (SAT) = 0.5$ V or less]

Sensor scheme

Example 1: In case steady running

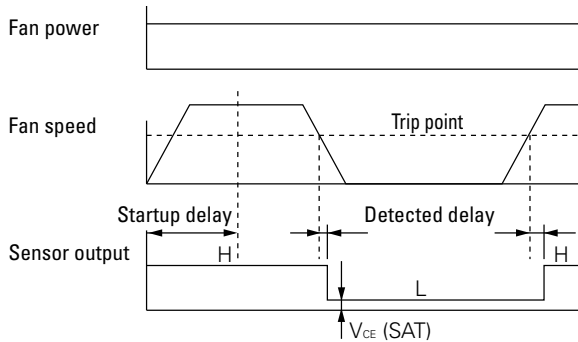

Inside of DC fan

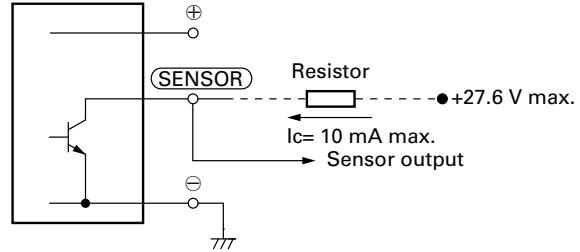

Example 2: In case that the rotor is locked when the fan motor is turned on and released after the start-up delay time.

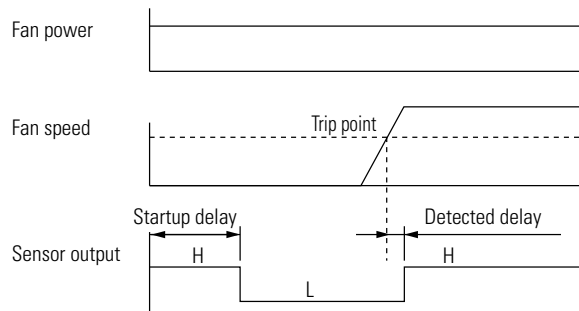

Specifications for AC Fan Sensor

ACDC fan sensor specifications differ from those below. Please refer to each product page.

Specifications of sensor circuit

	5 V (ITEM-20*)	12 V (ITEM-30*)
Example of model.no	109S405UL	
System	Speed detection, Auto-restart, Open collector	
Power supply	5 VDC±10% At 5 V, 6 mA	12 VDC±20% At 12 V, 10 mA
Recommend sensor circuit output	At $V_p = 5$ V, $I = 100$ mA max.	At $V_p = 12$ V, $I = 200$ mA max.
Trip point	Standard speed: $1700 \text{ min}^{-1} \pm 10\%$ Low speed: $850 \text{ min}^{-1} \pm 10\%$	
Response speed	Standard speed: Startup delay 18 s Detection delay 1 s Low speed: Startup delay 36 s Detection delay 2 s	
Insulation resistance	10 MΩ min. at a 500 VDC megger (Note)	
Dielectric strength	50/60 Hz, 1000 VAC, 1 minute (Note)	
Ambient conditions	Temperature: -10 to $+70^\circ\text{C}$, humidity: 90% RH max. (at 40°C)	



*[ITEM-20] and [ITEM-30] are printed on the fan nameplate.

Note: Between one end that all sensor leads consisting of brown, yellow and black are tied together and the G terminal or power terminal of the fan.

Sensor scheme

Example 1: When the AC power for the fan and the DC power for the sensor are turned on at the same time

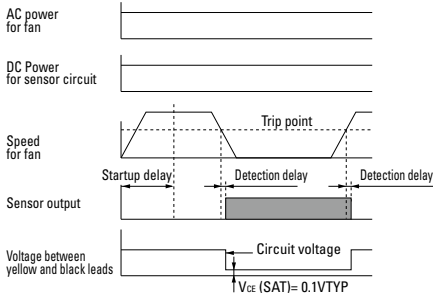

Example 2: When the AC power for the fan is turned on first, then the DC power for sensor is powered on

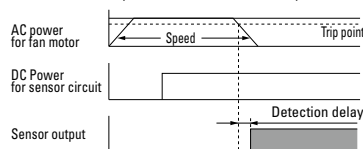

Example 3: When the DC power for sensor is first powered on, then the AC power for the fan is turned on

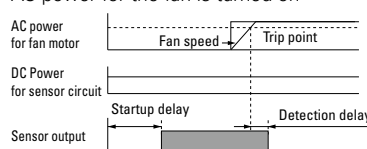

Sensor output circuit

5 V (ITEM-20*)

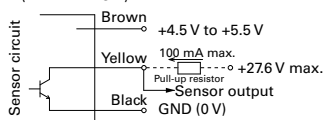

12 V (ITEM-30*)

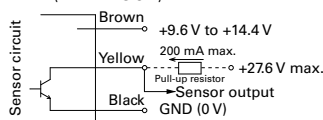

GND (Black) should be shared in case that power supply for sensor circuit (Brown) and that for sensor pull-up (Yellow) are separated.

Fans with PWM Control Function

PWM control function

1. Overview

Pulse Width Modulation (PWM) control function enables you to externally control the speed of the fan by varying the duty cycles of PWM input signals between control and grounding terminals. It allows fans to operate optimally in response to the device's heat level, lowering the noise and power consumption of the system.

PWM control function has the following advantages:

- (1) Because the PWM signal is digitally input, precise control is possible.
- (2) Because the PWM signal is digitally input, multiple fans can be controlled.
- (3) Upon users request, how the fan speed responds to PWM signals can be customized. For example, fan can be set to stop or run at low speed at 0% PWM duty cycle.

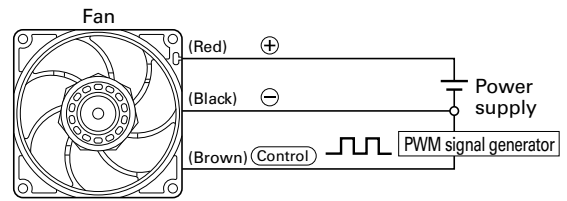

2. PWM duty input signals and wiring diagram

Other than a TTL input, an open collector/drain input can be used for PWM signal input.

Be noted that if an open collector/drain input is used or applied an input voltage and frequency is out of specified range, how the fan speed responds to the PWM duty cycle may be altered.

The input signal voltage and the frequency differ with models. Please contact us for details.

Example of input signal (TTL input)

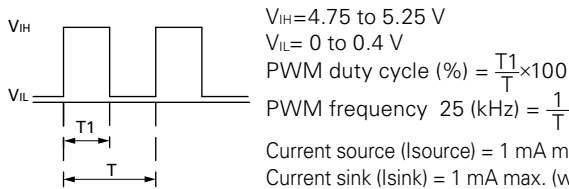

Current source (I_{source}) = 1 mA max. (when control voltage is 0 V)
 Current sink (I_{sink}) = 1 mA max. (when control voltage is 5.25 V)
 Control terminal voltage = 5.25 V max. (when control terminal is open)
 When the control terminal is open, fan speed is the same as when PWM duty cycle is 100%.

Wiring example

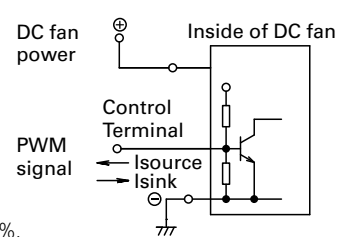

3. PWM duty cycle – Speed characteristics

Fan speed of PWM control fans change, as the below performance curve shows, in response to the PWM duty cycle input.

If necessary, users can do the speed setting by themselves, making the fans operate at the optimum speed.

Also, upon user's request, how fan speed responds to a PWM signal can be customized so that the fan stops or runs at low speed for a certain PWM duty cycle input. The below performance curve is for a fan that stops at 0% PWM duty cycle. Specifications differ with models. Please contact us for details.

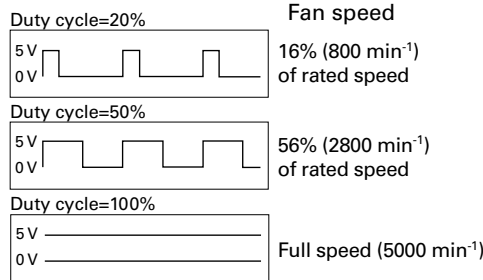
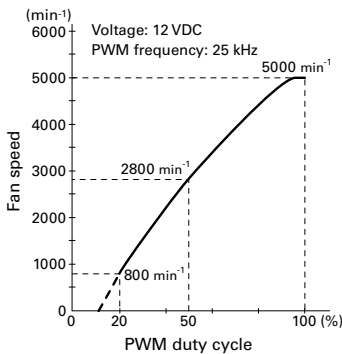

The dotted part of the performance curve (area below 20% PWM duty cycle in the above case) indicates the fan speed is unstable in the area.

4. When you wish to obtain a fan performance with 100 or 0% PWM duty cycle without a PWM signal generator for built-in test.

Performance at 100% PWM duty cycle: Leave the control lead wire open and no connection.

Performance at 0% PWM duty cycle: Connect the control lead wire directly to \ominus pin.

5. Application examples of PWM control fan

Here are a few application examples of PWM control fan.

(1) This system controls the fan speed in response to changing device temperature.

By combining a PWM control circuit and thermistor that detects temperature of device and its parts, it is able to control the fan speed of PWM control fan in response to the changing temperature.

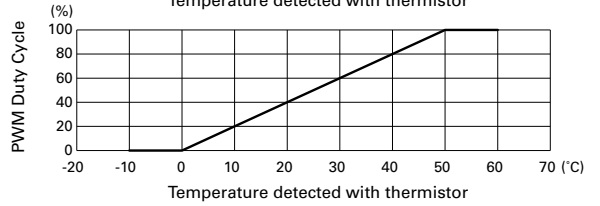
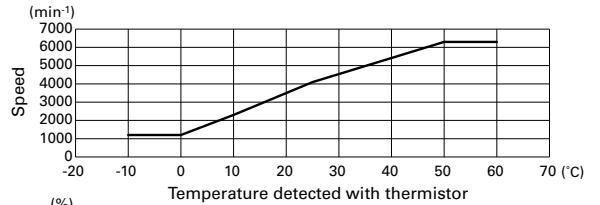
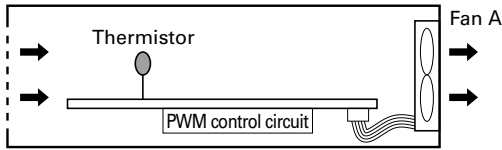

(2) Simultaneous control of multiple fans

Because PWM control is done with digital signal inputs, regardless of fan types or input voltage, multiple fans can be controlled simultaneously.

Below figure shows a system that can control multiple fans with various PWM characteristics simultaneously. Such systems contribute to the low power consumption and noise.

Operation mode	PWM Duty	Fan A	Fan B, C
Full-power	100%	5000 min ⁻¹	5000 min ⁻¹
Normal	60%	3500 min ⁻¹	4000 min ⁻¹
Standby (eco mode)	0%	Stop	1500 min ⁻¹

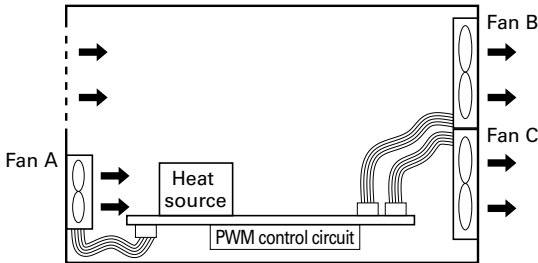

Fan A (model that stops at 0% PWM duty cycle)

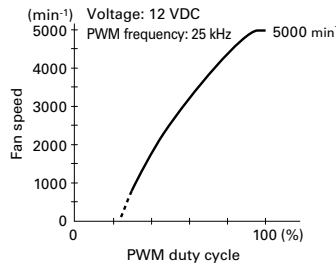

Fan B, C (model that runs at low speed at 0% PWM duty cycle)

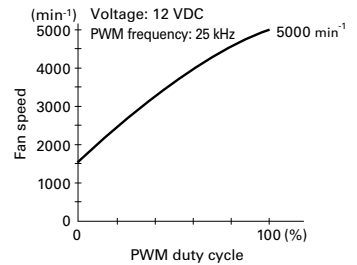

Controlling device that easily regulates the rotational speed of PWM control fans

San Ace PWM Controller

■Features

Reduces system power consumption and fan noise

For PWM fan speed control, a PWM control circuit needs to be newly designed and configured.

By using this product, however, PWM control function fans can be fully utilized without the need for preparing new circuits, contributing to reducing the system power consumption and the fan noise.

Can be common-powered by the fan power supply

The controller can be powered by the fan power supply of rated voltage 12, 24, and 48 VDC, and no separate supply is required.

Maximum of four fans connectable

Up to four fans with PWM control function can be connected and controlled.

Please refer to page 574 for detail.

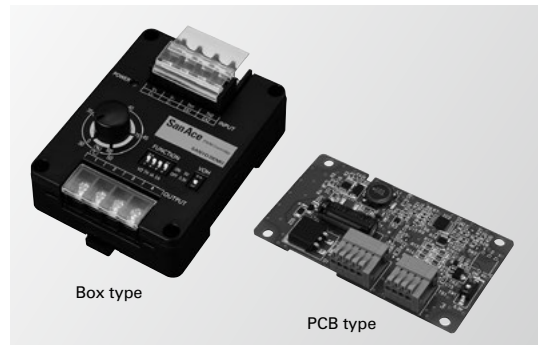

Splash Proof Fan

Ingress protection ratings (IP code)

- IP Codes used by SANYO DENKI express the level of protection that internal electrical components (for fans: electrical components and motor coils) have against solid objects, water, and access to hazardous parts. San Ace Splash Proof fans feature high protection levels.



Protected electrical components and motor coils

- Definition of Ingress Protection (IP Code)
Ingress Protection (IP Code) is defined in IEC (International Electrotechnical Commission) 60529* DEGREES OF PROTECTION PROVIDED BY ENCLOSURES (IP Code). *IEC 60529:2001

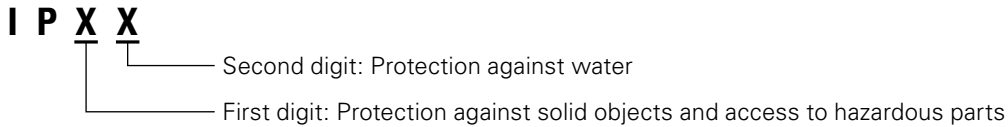

First digit	Definition
0	No protection
1	Protection against solid objects > 50 mm
2	Protection against solid objects > 12.5 mm
3	Protection against solid objects > 2.5 mm
4	Protection against solid objects > 1 mm
5	Protection against a level of dust that could hinder operation or impair safety
6	Complete protection against dust

Second digit	Definition
0	No protection
1	Protection against dripping water
2	Protection against water spray up to 15°
3	Protection against spraying water
4	Protection against splashing water
5	Protection against low pressure water jets
6	Protection against high pressure water jets
7	Protection against temporary immersion in water
8	Protection against submersion in water

- IPX8 Requirements
When the power is off, the fan is submerged in water pressurized to the equivalent of 2 meters for 60 minutes. Then it's run for 15 minutes at the rated voltage in free-air. During the test, there shall be no reduction in dielectric strength or fan characteristics.

UPS, inverter, rectifier, high-voltage power supply, etc.

Cautions for Use of a Cooling Fan in the Vicinity of a Power Switching Circuit (prevention of electrolytic corrosion)

If a fan is installed near a large-power or high-voltage switching circuit, the heavy electromagnetic noise resulting from electromagnetic induction in such circuits or the influence of high-frequency noise imposed through the power line of the fan may induce current through the shaft bearing of the fan. Such current may damage the oil film on the bearing and even the friction surface of the bearing. This adverse effect is known as "electrolytic corrosion of the fan." Electrolytic corrosion affects the smooth revolution of the fan and may reduce its service life. An audible symptom is unusual noise emitted from the fan. This adverse effect is often observed and may partly be explained by the practice of mounting high-density parts, which reduces the gap between the switching circuits and the fan and the use of higher switching frequencies apt to provoke induction. Data processing/communications devices that operate at low voltages are not liable to electrolytic corrosion since they generate less electromagnetic noise.

A Case of electrolytic corrosion

Fans without anti-corrosion features installed near components that generate electromagnetic noise, such as inverter controllers, are liable to experience electrolytic corrosion.

No.	Use	Period until the occurrence of unusual noise
1	Switching power supply	6 months to 2 years
2	UPS	6 months to 2 years
3	General-purpose inverter	1 to 1.5 years
4	Air cleaner	2 to 3 months
5	Inverter for LCDs	6 months

The curve shown in the graph below represents the relationship between the level of the electromagnetic noise induced by a fan and the distance from the fan to the noise source.

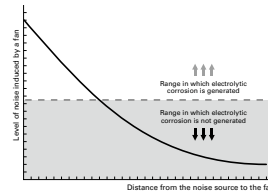

Occurrence of electrolytic corrosion Pattern 1

1. The fan gets charged with high-frequency electricity by high-frequency noise (electric field/magnetic field) generated in the switching circuit.
2. Because of high-frequency electricity charged in the fan, an electric current flows through the bearing of the fan.
3. The electric current breaks the oil membrane on the surface of the bearing and the bearing gets abraded (electrolytically corroded).
4. This symptom often occurs in equipment in which switching circuits are sped up and implemented in high density.
5. Countermeasure 1: To provide a shield plate⁽¹⁾ inside the fan (The plate should be such that does not interfere with airflow).
6. Countermeasure 2: To use a fan with ceramic bearings.

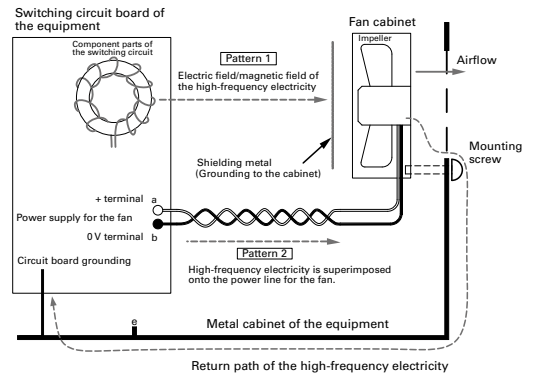

Occurrence of electrolytic corrosion Pattern 2

1. High-frequency electricity flows from the circuit board into the inside of the fan superimposed with the power line for the fan.
2. High-frequency electricity that has entered into the fan flows through the bearing.
3. Oil membrane on the surface of the bearing gets broken and the bearing gets abraded (electrolytically corroded).
4. Countermeasure 1: To remove high-frequency component between terminals "a" and "b", "a" and "e" and "b" and "e" of the power supply for the fan, or to insert a filter⁽²⁾ into the power line for the fan.
5. Countermeasure 2: To use a fan with ceramic bearings
6. Cables should be twisted in order to decrease induction to the power line for the fan.

(1) Shielding metal plate
As an electromagnetic shield metal, "EMC Guard" is available from our company. Certain shielding effect can be expected from mounting a general-purpose finger guard inside the fan. In each case, grounding to the cabinet is required.

(2) Filter
Insert a common mode filter when the high-frequency electricity is superimposed on both lines "a" and "b" in the same phase and, if not, insert a normal mode filter.

Measures against electrolytic corrosion

- Relocate fans far from all electromagnetic noise sources.
- Attach an EMC guard to ordinary fans. This should have an effect on electromagnetic noise due to radiation.
- As a power supply, the fan is wired from a circuit for which noise is not superimposed.
- Against heavy electromagnetic noise (electromagnetic induction) and conductive noise from the power supply line for a fan, we recommend the use of an "Electrolytic corrosion proof fan" with ceramic bearing.

This cooling fan prevents electrolytic corrosion of bearings even under conditions where electromagnetic noise is generated.

Electrolytic corrosion of ball bearings is prevented by using ceramic balls in ball bearings. The ceramic material is an insulating material. Manufacturable to meet specifications of all San Ace series fans.

■ Component diagram

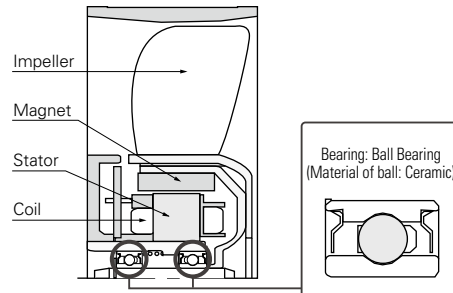

Caution

Electrolytic Corrosion Proof Fan has been designed to prevent the electrolytic corrosion of ball bearings in the fan, but this does not guarantee that the fan will operate normally under conditions where there is strong electromagnetic noise.

Please be sure to fully evaluate the value of fan malfunction due to noise in advance.

Safety Standards

Our products conform to these directives and safety standards. For compliance with standards, see individual product pages. Safety standard registration numbers are as follows.

Standard name	UL	CSA	TÜV
Certification number	E46810	172248	Varies by model

1. UL ratings (USA)



Underwriters Laboratories Inc. was established by the American Union of Fire Insurance Underwriters. The purpose of UL is to ensure safety of machines, equipment, and materials and protect human lives and property from fire and other accidents. To that end, UL has conducted numerous tests and extensive research and, as a result, set up UL ratings. Any seller of products in any of the majority of the states of the USA must produce their products according to the UL ratings, have them pass UL-specified safety inspections, and have them listed in UL's registration book. Therefore, to export and sell any product in the United States, one must in most cases apply for UL-listing. Additionally, UL is accredited by The Standards Council of Canada (SCC) as both a Certification Organization (CO) and a Testing Organization (TO) and is officially recognized in all provinces and territories throughout Canada. Accordingly, our products can be tested by UL for compliance with Canadian safety standards. Certified products are entitled to display the cUL Mark, which authorizes their use and sale in Canada. If products are deemed to be compliant with both U.S. and Canadian standards, then both the UL Mark and cUL Mark can be displayed or a combination U.S. and Canadian mark (bottom left). Our fans are certified as satisfying all UL 507 requirements.

2. CSA standards (Canada)



The Canadian Standards Association (CSA) was set up in response to the advice of the Canadian government. In Canada, the law prohibits the use and sale of any product other than those approved under CSA in terms of safety. CSA has set up CSA standards as inspection procedures and other requirements to ensure product safety. Our products are certified as satisfying the CSA standard C22.2 No. 113.

3. EN standards (EU members)



In the EU territory, the harmonization of industrial standards and safety standards of different countries is under way. The unified standards are called Harmonized Standards. Each of these standards is marked EN above the standard number. EN standards offer the grounds in design and manufacture when one exports a product to the EU territory. In order for a product to receive a safety marking, the product must be found to conform to TÜV, VDE, or other relevant standard. Our products are certified by TÜV Rheinland to meet the requirements of EN 60950-1/EN 62368-1. (San Ace Controller complies with EN 60730-1)

4. Electrical appliance and material safety law



As of April 1, 2001, the Electrical Appliance and Material Control Law has been revised and reenacted as the Electrical Appliance and Material Safety Law. AC fans are classified as 'Blowers' under 'Electric motor-operated appliances'. They are categorized as electrical products other than specific electrical appliances (with the exception of some models) and are required to be labeled to indicate PSE certification.

5. CE marking



To distribute their equipment in the EU territory, manufacturers are obligated to give a CE marking as proof that the equipment conforms to related EC directives. Manufacturers use EN standards as criteria of judgment as to whether the equipment satisfies the requirements of specific directives or, in the absence of applicable EN standards, they use IEC standards. Manufacturers then prepare a self-declaration to indicate that the equipment conforms to related directives and apply a CE marking. (Depending on the degree of risk of the equipment, some kinds of equipment are required to receive type tests conducted by certified authorities and, after a type test certificate is obtained, manufacturers make a self-declaration.)

Scope of application of major EC directives

Machine directives

These directives apply to equipment that has a moving part that may injure humans. The directives generally apply to a wide range of machine tools and other industrial machines.

EMC directives

They apply to equipment which may be affected by electromagnetic interference (EMI) or has electromagnetic susceptibility (EMS).

Low-voltage directive

This directive applies to equipment that is used in an AC range between 50 and 1000 V and in a DC range between 75 and 1500 V.

ErP Directive

Energy related Products Directive aims to protect the environment and requires eco-design.

RoHS Directive

This directive restricts the use of certain hazardous substances contained in electrical and electronic equipment.

Radio Equipment Directive

This directive sets requirements that radio and communications equipment should meet.

6. Technical Standard Conformity Certification



The Technical Standard Conformity Certification mark, set by Japanese Ministry of Internal Affairs and Communications, indicates that the product is certified as either or both of the following: specific radio equipment defined in the Radio Act and terminal equipment defined in the Telecommunications Business Act. Our San Ace Controller has built-in Technical Standard Conformity-certified specific radio equipment defined in the Radio Act in Japan. It is also a certified terminal equipment based on the Telecommunications Business Act in Japan.

7. VCCI



VCCI is a membership organization in Japan that aims to suppress electromagnetic interference generated from information technology equipment by industry self-regulation. It sets standards for noise, which affects other communications equipment, generated from data-processing equipment. VCCI categorizes information technology equipment in two classes: Class A equipment is used in commercial and industrial areas and Class B equipment is used in residential and adjacent areas. Our San Ace Controller is categorized as Class B information technology equipment.

8. FCC



Federal Communications Commission (FCC) is an independent U.S. government agency responsible for implementing and enforcing U.S. communications law and regulations. Obtaining an FCC certification is required to sell communications equipment including radio equipment in the U.S. Our San Ace Controller complies with FCC Part 15 Class B.

RoHS Directive Compliance

All products listed in this catalog conform to the EU RoHS Directive 2011/65/EU and EU 2015/863.

These Directives restrict the following ten hazardous substances: cadmium, lead, mercury, hexavalent chromium, PBB, PBDE, DEHP, BBP, DBP, and DIBP. Implementation schedule is as follows:

Products	Implementation date
Fans, PWM Controller, San Ace Controller	Produced in and after January 2019
Plug cords	Shipped in and after October 2018
Finger guards, filter kits	Shipped in and after January 2018
Airflow Tester	Produced in and after July 2019

Eco-products

Efforts for designing Eco-products

As for product design, we are carrying out R&D to incorporate the latest energy-saving technologies into our new products. At the same time, we carry out product assessments to evaluate the environmental impact of products at each stage, such as component and material procurement, manufacture, distribution, use, recycling, and disposal.

Newly developed products are compared with commercially available and existing products and are certified as Eco-products (Eco-design products) if they satisfy the specified evaluation standards. Eco-products are presented in catalogues and other materials with a LEAF symbol.



Life cycle assessment (LCA)

LCA is one of the techniques used to provide a general quantitative measure of levels of environmental impact including global warming that products have through their life cycles. We evaluate the environmental compatibility of a product using this method. Our rate of implementing LCA in our Eco-products was 90%.

Operating Precautions Fan

Temperature conditions

Operating temperature: Refer to the specifications table for each model.

Storage temperature: -20 ~ +70°C / -30 ~ +70°C (Varies for each model / Non condensing)

Rapid change in temperature may cause condensation. Prevent condensation when storing. Condensation may affect lubrication performance and insulation.

Power specifications

For the specification of rated voltage and voltage range, please check the catalog or drawing for the model number.

Use of voltage exceeding the specified range may lead to performance degradation, device failure, or fire hazards. Do not apply voltage that exceeds specifications to the fan.

An electronic circuit is used for the DC fan. For power supply, use power with ripple less than 5% with low line noise and surge to prevent electronic circuit trouble.

Handling precautions

The fan motor is equipped with a precision ball bearing. Therefore, please handle the motors carefully in order not to shock the bearings.

Installation tips

There are no limitations on the installation direction of fans or blowers. Fans have symbols on the fan indicating the airflow direction and blade rotation direction. When installing, use these symbols to check the airflow direction.

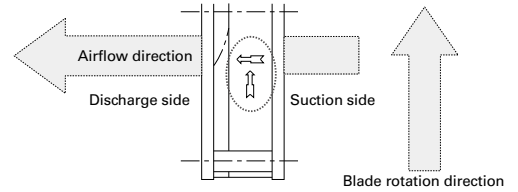

Symbols indicating the fan airflow direction and blade rotation direction

Recommended screw torque

This shows the recommended values for the screw torque when installing the fans. If the tightening torque is higher than the recommended values, the fan can be deformed or damaged.

Use care when tightening. Also, be sure to always use a fan with a ribbed structure when securing by screws with both flanges.

DC fan

Fan mounting hole diameter [mm]	Nominal screw diameter	Recommended screw torque
ø3.5, ø3.7	M3	0.44 N·m max.
ø4.3, ø4.5	M4	0.78 N·m max.
ø4.3, ø4.5	M4	0.98 N·m max. (ø172 mm×51 mm, ø172 mm×150 mm×51 mm, ø200×70 mm)

AC fan

Fan mounting hole diameter [mm]	Nominal screw diameter	Recommended screw torque
ø3.5, ø3.7	M3	0.44 N·m max.
ø4.3	M4	0.58 N·m max. (120 mm×120 mm max.)
ø4.3	M4	0.78 N·m max. (ACDC fan, ø172 mm)
ø5.5	M4, M5	0.78 N·m max. (160 mm×160 mm)

Comparison of ribbed and ribless structures

Regarding plastic frame, we have a option ribbed and ribless about mounting. Please use preferred type up to your application. Please use ribbed fan in case that you hook fan up clamping either side fan mounting hole target. (According to the model, only models with or without ribs are available.)

*Use a fan with a rib structure when securing by screws with both flanges.

When securing screws to ribless plastic frame models, use a flange to secure on one side.

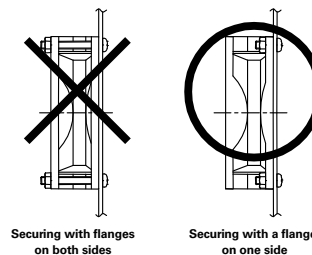
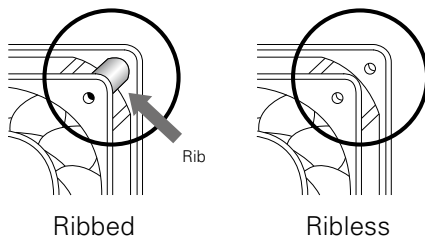

Fan Mounting Using Self-tapping Screw

Installing self-tapping screws into the plastic frame of the fan may split or deform it.

If using self-tapping screws, use screws that are recommended by our company, and refer to our recommended tightening torques and recommended pilot hole shapes. Pay close attention to the operating precautions and fully understand your equipment before you use it.

Recommended screw torques

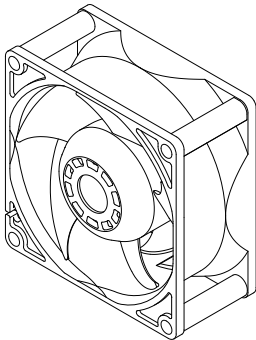

Fig. A: Ribbed fan

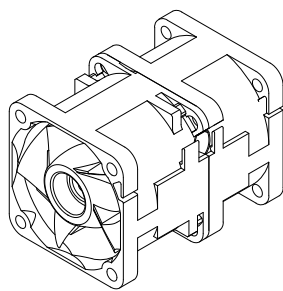

Fig. B: Counter rotating fan

	Recommended screw torque [N·m]	Fan mounting hole diameter [mm]
Ribbed fan (Fig. A)	0.8 max.	ø3.5. ø4.3. ø4.5
Counter rotating fan (Fig. B)	0.6 max.	

Do not use self-tapping screws in the following cases:

- For ribless fans (except for counter rotating fans)
- When mounting finger guards on fans

Using self-tapping screws could deform or split the frame. Please use regular screws.

Recommended pilot hole shape

[For nominal diameter 4 mm]

Self-tapping screw model no.
SY-NS020412P11

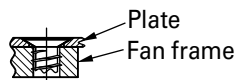
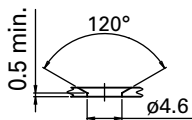

Self-tapping screw model no.
SY-NS010412P11

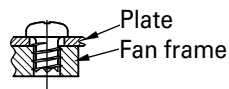
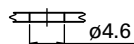

Minimum mounting plate thickness: T=1.2 mm

[For nominal diameters of 4.8 mm and 5 mm]

Self-tapping screw model no.
SY-NS024812P15
SY-NS020512P15

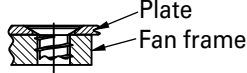
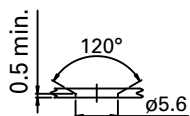

Self-tapping screw model no.
SY-NS014812P15
SY-NS010512P15

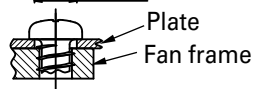
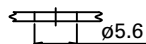

Minimum mounting plate thickness: T=1.2 mm

Recommended self-tapping screws

· Material: Steel

· Plating: Trivalent chromating plating

unit: mm

Fan mounting hole diameter	Self-tapping screw model no.	Nominal screw diameter	Length [L]	Head shape	Flat-head/pan-head dimensions		
					Head diameter [D]	Height of head [H]	Cross recess No.
ø3.5	SY-NS020412P11	4	12	Flat	6.2	1.1 max.	2
	SY-NS010412P11	4	12	Pan	5.5	2.0	2
ø4.3	SY-NS024812P15	4.8	12	Flat	6.8	1.2 max.	2
	SY-NS014812P15	4.8	12	Pan	7.0	2.6	2
ø4.5	SY-NS020512P15	5	12	Flat	6.8	1.2 max.	2
	SY-NS010512P15	5	12	Pan	7.0	2.6	2

Head shape: Flat

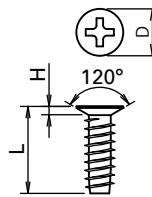

Head shape: Pan

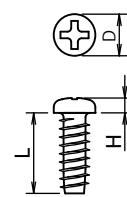

Operating precautions

- Place the self-tapping screw so that it is vertical and centered with the frame mounting hole (Fig. A) and then screw it in. The self-tapping screw could deform or split the frame if you screw it into the frame when the screw is not vertical.
- Screw in the self-tapping screw with the center of the mounting hole on the fan and the center of the pilot hole on the mounting plate aligned (Fig. B). Misaligned holes could lead to the frame being deformed or split.

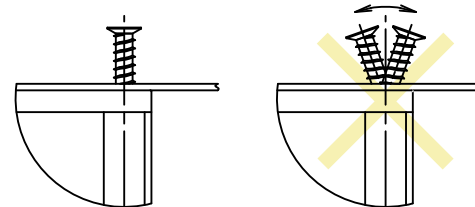

Vertically placed screw

Inclined screw

Fig. A

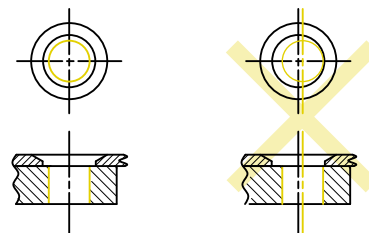

Aligned and centered holes

Misaligned holes

Fig. B

- Tightening the screw beyond the recommended screw torque could deform or split the frame.
- With flat-head screws, failure to use the recommended pilot hole shape will cause interference between the flat-head screw and fan frame which could split the frame.

Recommended screw manufacturer

To purchase the screws, please contact the screw manufacturer directly.

SAIMA CORPORATION

2-9-17 Tsujido Fujisawa Kanagawa 251-0047 JAPAN



TEL:+81-466-36-3656 FAX:+81-466-36-0009

<https://www.saima.co.jp/en/top.php>

Safety Precautions Fan

- To ensure that this fan is used safely, be sure that you read and understand the following precautions fully and use it only as directed.
- Be sure to read these Safety Precautions carefully before installing, connecting, operating, maintaining, or inspecting the fan. Follow all the precautions and directions given here.
- The fan has been designed and manufactured for built-in use in general industrial machinery, and might not be used otherwise.
- The fan falls into the Category 16 (Class 84, Item 14) of the Appended Table 1 of the Export Trade Control Order. When exporting the fan either as a standalone item or as part of another product, be sure to implement the necessary procedures including the "Informed Cases" and "Objective Cases" based on the "Catch-All Controls" defined by the Ministry of Economy, Trade and Industry of Japan.
- When disposing the fan, treat it as industrial waste. For instructions on proper disposal methods, please contact local government authorities.
- When using the fan in equipment that could affect people's lives or health, that is used on a car, ship, or aircraft, or that could have a major impact on society or on the public, use it at your own discretion only after deploying sufficient safety measures and making prior evaluation.
- Fully understand the Safety Precautions described in this document before using the product. SANYO DENKI will not be liable for any accidents resulting in death, injury, or property damage due to the failure of the fan.

Safety precautions necessary for preventing any possible bodily injury or damage to property or equipment are ranked in two levels:

 Warning	Denotes hazards which could cause severe bodily injury or death as a result of incorrect operation.
 Caution	Denotes hazards which could cause bodily injury or property damage as a result of incorrect operation.

Note: Even those items marked 'Caution' might also result in serious consequences depending on the situation. Be sure to observe them carefully to the same extent as items marked 'Warning.'

Descriptions of the precautions to be taken to ensure safety are given below.

Warning

- When using the fan in the following equipment, use it at your own discretion only after deploying sufficient safety measures and making prior evaluation.
 - Equipment that could affect people's lives or health
 - Equipment that is used on a car, ship, or aircraft
 - Equipment that could have a major impact on society or on the public
 SANYO DENKI will not be liable for any accidents involving human casualties (death, injury, etc.) or property damage due to the failure of the fan while use in such equipment.
- Ensure that wiring is done correctly. Failure to do so might result in fire, burns, or electrical shock.
- If there are any grounding taps or wires, ground them securely. Failure to do so might result in electric shock.
- Never use in explosive atmospheres, as doing so might result in fires, burns, or bodily injury.
- Do not operate the fan with live parts exposed. Doing so might result in electric shock.
- Never allow any persons or objects to approach or come into contact with the fan's rotor while in operation, as doing so might result in damage or personal injury.
- Turn off the power and stop using the fan immediately if you notice any sparks, smoke, odd odors or sounds, or anything unusual during operation. Failure to do so might result in fire, bodily injury, or electrical shock.
- Never allow the fan to fall, topple over, or be subjected to excessive shocks when moving it. Doing so might result in product failure or performance deterioration.
- The fan should be handled by technically qualified personnel or someone with sufficient expertise; the personnel shall be assigned at your own discretion.
- Never attempt to disassemble, repair, or alter the fan in any way, as doing so might result in electrical shock, fire, or bodily injury.

Caution

Handling

- Installation, mounting, connections, wiring, and relocation of the fan should be done by technically qualified personnel or someone with sufficient expertise; the personnel shall be assigned at your own discretion.
 - Never perform such work while the product is on, as this might lead to injury, electrical shock, burns, or fire.
- Do not operate the fan if it is not secured, nor while held in hand.
- Never allow yourself to come into contact with the fan when measuring insulation resistance or dielectric strength. There is danger of electric shock.
- Never attempt to disassemble or alter the fan in any way. Doing so might not only result in substandard performance, but also fire, burns, bodily injury, or electrical shock.

Operation

- Take protective measures for the equipment in which the fan is embedded in case the fan stops, malfunctions, or fails during operation.
- Never use the fan at voltages, temperatures, or any other parameters exceeding those given in the product specifications. Otherwise, it might result in substandard performance, failure, fire, bodily injury, or electrical shock.
- Using a power supply with insufficient capacity might result in faulty fan operation because an inrush current several times larger than the rated current will flow at the moment of fan startup. Be sure to use a power supply with sufficient capacity.
- Start all fans at the same time when two or more fans are positioned in equipment in a way that creates wind interference. If the fan is exposed to wind from other fans at startup, it might result in fan failure or faulty fan startup. Also, evaluate the influence to individual fans in advance and use them at your own discretion.
- Never connect or disconnect lead wires, plug cords, or connectors while the power is on. Be sure to connect or disconnect them while holding the frame only after power-off. Otherwise, it might result in fan damage or electrical shock.
- Do not remove the lead wire of the fan from the frame hook. Doing so might scratch and damage the surface of the lead wire.
- Do not remove the nameplate. Doing so might result in fan failure or electrical shock.
- Do not press down hard on the nameplate of the fan. Otherwise, the nameplate might break or come into contact with the shaft, hindering proper operation.
- The fan might be damaged or burned out if foreign objects or external forces hinder normal fan operation.
- Do not use the power supply's PWM to control the speed of the fan. Doing so might result in fan malfunction.
- Do not turn the power on or off on the negative power line. Doing so might damage the fan.
- Turning the power on and off frequently or turning the power back on before the fan comes to a complete stop might result in fan failure or damage. Before conducting such operations, fully evaluate the equipment in which the fan is embedded.
- The protection of fans with IP ratings (Splash Proof Fans) applies only to the live parts (electronic components and motor coils) of the fan in accordance with IEC 60529. The protection does not apply to the non-live parts of the fan. If the fan is to be used for a long period of time in an environment subject to dust, water, or condensation, take measures required for the operating environment.
- Do not wash the fan during maintenance of equipment. Doing so might result in failure of the fan.

Installation (Common to All Fans)

- Install and secure the fan properly with its weight and vibration during operation taken into account. Failure to do so might result in bodily injury or equipment failure due to the fan or its parts falling off.
- Ensure that the fan is installed in the right orientation. Failure to do so might result in bodily injury or equipment failure.
- For the fan to perform to its full capacity, secure air vents and take measures to prevent foreign objects from entering the fan. Failure to do so might result in bodily injury or fan failure.
- Do not subject the fan to excessive shock. Doing so might result in failure or substandard performance of the fan.
- Pulling or pinching lead wires might result in damage and stress to the wire. Also, make connections so that the lead wires do not come into contact with the rotating blades. Failure to do so might result in equipment failure or electrical shock.
- Take proper precautions against static electricity when wiring. Failure to do so might cause failure of the fan or equipment.
- Take safety measures such as installing a finger guard and displaying a warning symbol if there is any danger of fingers or objects coming into contact with the rotating blades. Failure to do so might result in bodily injury or fan failure.
- When installing an inlet nozzle, finger guard, or base plate to the fan, ensure that they are positioned correctly according to this Product Specification and other documents so that they do not come into contact with the rotating blades. Also, operate the fan after checking that the rotating blades do not come into contact with anything. Otherwise, it might result in equipment failure. Please use only genuine SANYO DENKI inlet nozzles and finger guards.
- Make connections correctly in accordance with the information of this Product Specification and the nameplate of the fan. Failure to do so might result in equipment failure or the malfunction, failure, or performance degradation of the fan.

Installation (Axial Fan and Blower)

- When mounting the fan with screws, make sure that the screw and base plate will not deform the frame of the fan before mounting. A deformed frame might result in failure or substandard performance of the fan.
- When mounting the fan with screws, ensure that the screw tightening torque is correct. If the tightening torque exceeds the recommended torque, the fan frame might be deformed or damaged. Choose a ribbed frame model if mounting fans with plastic frames through both sides of the frame with through-screws. To prevent loose screws, use plain washers or spring washers. For the screwing torque of each fan type, contact SANYO DENKI or a SANYO DENKI distributor.
- Avoid mounting the fan with self-tapping screws, as doing so might damage the fan frame.
If using self-tapping screws, be sure to choose the screw that we recommend and conduct evaluations before using it.

Installation (Centrifugal Fan)

- The fan shall be mounted with screws. For the screw size for each fan model, see this Product Specification.
- Choose screws with the right length with information such as the fan mounting depth and base plate thickness taken into account. Failure to do so might result in stripped screw holes and improper fan mounting. For the mounting depth of each fan model, see this Product Specification.
- Ensure that the screw tightening torque is correct. If the tightening torque exceeds the recommended torque, the screw hole might be deformed or damaged. Also, to prevent loose screws, use plain washers or spring washers. For the tightening torque for each fan model, see this Product Specification.
- For the inlet nozzle and base plate installation dimensions for each fan model, see this Product Specification.

Operating Environments

- Avoid using or storing the fan in the following environments. Otherwise, it might result in fire or the failure or performance degradation of the fan.
In environments where flammable or corrosive gas is present, where water or oil splashes, where there is much dust or humidity, where condensation occurs, where exposed to radioactive rays or direct sunlight, where a salty sea breeze blows or seawater splashes, where the fan might be contaminated by such corrosive materials as sulfurous water, sulfurous volcanic ash, organic solvents, acidic and alkali chemicals, or nuclear fuel materials, where subjected to constant vibration, strong shocks, centrifugal force, acceleration, or strong magnetic force, where electromagnetic noise radiation is present, where the electromagnetic noise overlaps into power voltage, or where subjected to rapid environmental fluctuations (temperature, humidity, pressure, etc.).

Storage

- The fan should be stored in packaging.
- Ensure that the fan is stored in the following environments where:
 - the temperature is normal and stable;
 - the relative humidity is 20% to 85% with no sudden changes in humidity and no condensation;
 - not subjected to direct sunlight;
 - not subjected to water, oil, corrosive materials, or other hazardous substances;
 - and not subjected to vibration or shock.

Maintenance



- Maintenance and inspections of the fan should be done by technically qualified personnel or someone with sufficient expertise; the personnel shall be assigned at your own discretion. Otherwise, it might result in fire, burns, bodily injury, or electrical shock.
- Never perform any maintenance or inspections while the fan is in operation. Also note that the blades continue to rotate for some time immediately after operation ceases. Always confirm that all rotating parts have come to a stop before beginning work. Failure to do so might result in bodily injury.
- Never use gasoline, paint thinner, benzene, or any other organic solvents to clean the fan. Also, avoid placing excessive stresses on the fan. Otherwise, it might result in product deformation or performance degradation.

Safety Precautions San Ace Controller

Please read this instruction manual and its appendix carefully prior to installation, operation, maintenance or inspection and perform all tasks according to the instructions provided here.

A good understanding of this equipment, its safety information as well as all Warnings/Cautions is also necessary prior to operation. Matters that require attention are ranked as "Warning" and "Caution" in this document.

Warning Symbol

 Warning	Denotes immediate hazards which could cause severe bodily injury or death as a result of incorrect operation.
 Caution	Denotes hazards which could cause bodily injury and product or property damage as a result of incorrect operation.

Even those hazards denoted by this symbol  **Caution** could lead to a serious accident. Make sure to strictly follow these safety precautions.

Warning

- If the product is used in medical appliances or other types of equipment that affect people's lives, sufficient safety-related evaluations and preparations must be made in advance, and the product or the type of equipment into which the product is assembled must be used under the full responsibility of the user.
- If the product is used in types of equipment that have a strong social and public impact, sufficient prior evaluations and safety-related evaluations and preparations must be made, and the product or the type of equipment into which the product is assembled must be used under the full responsibility of the user.
- The product is not designed to be used in a car or a ship. When using the product in an environment with vibration, such as in a car or a ship, use it at your own discretion only after deploying sufficient safety measures and making prior evaluations.
- Connect all wires properly and securely. Failure to do so may result in fire, burns, or electrical shock.
- Never use in explosive atmospheres, as doing so might result in fires, burns, or bodily injury. Otherwise, it may result in fire, burns, or bodily injury.
- Do not operate the product when electronic components are exposed. Failure to do so may result in electrical shock.
- Turn off the power and stop using the product immediately if you notice any sparks, smoke, odd odors, sounds, or anything unusual during operation. Failure to do so may result in fire, bodily injury, or electrical shock.
- Never allow the product to fall, topple over, or otherwise be subjected to excessive shocks when moving it. Otherwise, it may result in product failure.
- The product should be handled only by personnel with sufficient training and knowledge and under the full responsibility of the user.
- Never attempt to disassemble, repair, or alter the product in any way. Doing so may result in fire, bodily injury, or electrical shock.

Caution

Handling

- Installation, placement, connections, wiring, or relocation of the product should be performed by knowledgeable or correctly licensed personnel. Never perform such work while the product is on. Doing so may result in fire, burns, or electrical shock.
- Never allow yourself to come into contact with the ends of wires or plugs when measuring insulation resistance or dielectric strength voltage. Failure to do so may result in electrical shock.
- Never attempt to disassemble or alter the product in any way. Doing so may invalidate any warranties concerning the functions or performance of the product, and may also result in fire, burns, bodily injury, or electrical shock.

Please Read:

Index by Model No. - DC Fans

Models listed in product pages	List of models (Below are optional models and not listed in product pages. Standard compliance of these optional models may differ from that of the models listed in product pages. Contact us for details of "—" models.)				Frame size	Rib	page
	Without sensor	With pulse sensor	With lock sensor	With PWM control function and pulse sensor			
	109BC12FC7-1	109BC12FA7-1	▶▶ 109BC12FC7-1	109BC12FD7-1			
109BC12GC7-1	▶▶ 109BC12GA7-1	▶▶ 109BC12GC7-1	109BC12GD7-1	—	52 × 15 mm	—	492
109BC12HC7-1	▶▶ 109BC12HA7-1	▶▶ 109BC12HC7-1	109BC12HD7-1	—	52 × 15 mm	—	492
109BC12MC7-1	109BC12MA7-1	▶▶ 109BC12MC7-1	▶▶ 109BC12MD7-1	—	52 × 15 mm	—	492
109BC24FC7-1	▶▶ 109BC24FA7-1	109BC24FC7-1	109BC24FD7-1	—	52 × 15 mm	—	492
109BC24GC7-1	▶▶ 109BC24GA7-1	▶▶ 109BC24GC7-1	▶▶ 109BC24GD7-1	—	52 × 15 mm	—	492
109BC24HC7-1	109BC24HA7-1	▶▶ 109BC24HC7-1	109BC24HD7-1	—	52 × 15 mm	—	492
109BD12FC2	▶▶ 109BD12FA2	▶▶ 109BD12FC2	▶▶ 109BD12FD2	—	76 × 30 mm	—	496
109BD12HC2	▶▶ 109BD12HA2	▶▶ 109BD12HC2	▶▶ 109BD12HD2	109BD12P2H01	76 × 30 mm	—	496
109BD12MC2	▶▶ 109BD12MA2	▶▶ 109BD12MC2	109BD12MD2	—	76 × 30 mm	—	496
109BD24FC2	▶▶ 109BD24FA2	▶▶ 109BD24FC2	109BD24FD2	—	76 × 30 mm	—	496
109BD24HC2	▶▶ 109BD24HA2	▶▶ 109BD24HC2	▶▶ 109BD24HD2	—	76 × 30 mm	—	496
109BD24MC2	▶▶ 109BD24MA2	▶▶ 109BD24MC2	▶▶ 109BD24MD2	—	76 × 30 mm	—	496
109BG12HC1	▶▶ 109BG12HA1	▶▶ 109BG12HC1	▶▶ 109BG12HD1	—	160 × 40 mm	—	512
109BG12MC1	▶▶ 109BG12MA1	▶▶ 109BG12MC1	109BG12MD1	—	160 × 40 mm	—	512
109BG24HC1	▶▶ 109BG24HA1	▶▶ 109BG24HC1	▶▶ 109BG24HD1	—	160 × 40 mm	—	512
109BG24MC1	109BG24MA1	▶▶ 109BG24MC1	109BG24MD1	—	160 × 40 mm	—	512
109BJ12HC2	▶▶ 109BJ12HA2	▶▶ 109BJ12HC2	109BJ12HD2	—	127 × 32 mm	—	510
109BJ12MC2	109BJ12MA2	▶▶ 109BJ12MC2	109BJ12MD2	—	127 × 32 mm	—	510
109BJ24HC2	109BJ24HA2	▶▶ 109BJ24HC2	▶▶ 109BJ24HD2	—	127 × 32 mm	—	510
109BJ24MC2	▶▶ 109BJ24MA2	109BJ24MC2	109BJ24MD2	—	127 × 32 mm	—	510
109BM12GC2-1	109BM12GA2-1	109BM12GC2-1	109BM12GD2-1	—	97 × 33 mm	—	506
109BM12HC2-1	109BM12HA2-1	109BM12HC2-1	109BM12HD2-1	—	97 × 33 mm	—	506
109BM12MC2-1	109BM12MA2-1	109BM12MC2-1	109BM12MD2-1	109BM12P2M01	97 × 33 mm	—	506
109BM24GC2-1	109BM24GA2-1	109BM24GC2-1	109BM24GD2-1	—	97 × 33 mm	—	506
109BM24HC2-1	109BM24HA2-1	109BM24HC2-1	109BM24HD2-1	—	97 × 33 mm	—	506
109BM24MC2-1	109BM24MA2-1	109BM24MC2-1	109BM24MD2-1	—	97 × 33 mm	—	506
109E1312A101	109E1312A102	109E1312A101	109E1312A1D01	—	127 × 127 × 38 mm	No	189
109E1312S101	109E1312S102	109E1312S101	109E1312S1D01	—	127 × 127 × 38 mm	No	189
109E1324A101	109E1324A102	109E1324A101	109E1324A1D01	—	127 × 127 × 38 mm	No	189
109E1324G101	109E1324G102	109E1324G101	109E1324G1D01	—	127 × 127 × 38 mm	No	189
109E1324S101	109E1324S102	109E1324S101	109E1324S1D01	—	127 × 127 × 38 mm	No	189
109E1348A101	109E1348A102	109E1348A101	109E1348A1D01	—	127 × 127 × 38 mm	No	189
109E1348G101	109E1348G102	109E1348G101	109E1348G1D01	—	127 × 127 × 38 mm	No	189
109E1348S101	109E1348S102	109E1348S101	109E1348S1D01	—	127 × 127 × 38 mm	No	189
109E1712F501	109E1712F502	109E1712F501	109E1712F5D01	—	∅172 × 51 mm	No	215
109E1712H501	▶▶ 109E1712H502	▶▶ 109E1712H501	109E1712H5D01	—	∅172 × 51 mm	No	215
109E1712K501	109E1712K502	▶▶ 109E1712K501	—	—	∅172 × 51 mm	No	215
109E1712M501	109E1712M502	▶▶ 109E1712M501	—	—	∅172 × 51 mm	No	215
109E1712Y501	109E1712Y502	109E1712Y501	—	—	∅172 × 51 mm	No	215
109E1724C501	109E1724C502	▶▶ 109E1724C501	109E1724C5D01	9EH1724P5C01	∅172 × 51 mm	No	215
109E1724F501	109E1724F502	109E1724F501	109E1724F5D01	—	∅172 × 51 mm	No	215
109E1724H501	▶▶ 109E1724H502	▶▶ 109E1724H501	▶▶ 109E1724H5D01	—	∅172 × 51 mm	No	215
109E1724K501	▶▶ 109E1724K502	▶▶ 109E1724K501	▶▶ 109E1724K5D01	—	∅172 × 51 mm	No	215
109E1724M501	▶▶ 109E1724M502	▶▶ 109E1724M501	109E1724M5D01	—	∅172 × 51 mm	No	215
109E1748C501	109E1748C502	▶▶ 109E1748C501	—	—	∅172 × 51 mm	No	215
109E1748F501	109E1748F502	109E1748F501	—	—	∅172 × 51 mm	No	215
109E1748H501	109E1748H502	▶▶ 109E1748H501	109E1748H5D01	—	∅172 × 51 mm	No	215
109E1748K501	109E1748K502	109E1748K501	—	109E1748P5K03	∅172 × 51 mm	No	215
109E1748M501	109E1748M502	109E1748M501	—	—	∅172 × 51 mm	No	215
109E4712L401	109E4712L402	109E4712L401	109E4712L4D01	—	∅172 × 147 × 25 mm	No	202
109E4712M401	109E4712M402	109E4712M401	109E4712M4D01	—	∅172 × 147 × 25 mm	No	202
109E4724F401	109E4724F402	109E4724F401	109E4724F4D01	—	∅172 × 147 × 25 mm	No	202
109E4724H401	109E4724H402	109E4724H401	109E4724H4D01	109E4724P4H01	∅172 × 147 × 25 mm	No	202
109E4724L401	109E4724L402	109E4724L401	109E4724L4D01	—	∅172 × 147 × 25 mm	No	202
109E4724M401	109E4724M402	109E4724M401	109E4724M4D01	—	∅172 × 147 × 25 mm	No	202
109E4748F401	109E4748F402	109E4748F401	109E4748F4D01	—	∅172 × 147 × 25 mm	No	202
109E4748H401	109E4748H402	109E4748H401	109E4748H4D01	—	∅172 × 147 × 25 mm	No	202
109E4748L401	109E4748L402	109E4748L401	109E4748L4D01	—	∅172 × 147 × 25 mm	No	202
109E4748M401	109E4748M402	109E4748M401	109E4748M4D01	—	∅172 × 147 × 25 mm	No	202
109E4748S401	109E4748S402	109E4748S401	109E4748S4D01	—	∅172 × 147 × 25 mm	No	202

Note 1: For compliance with standards, see individual product pages. Please contact your point of sale regarding low-speed sensors.

Note 2: The ▶▶ mark indicates Short Lead Time Service applicable models. See p. 654 for details.

Models listed in product pages	List of models (Below are optional models and not listed in product pages. Standard compliance of these optional models may differ from that of the models listed in product pages. Contact us for details of "-" models.)				Frame size	Rib	page
	Without sensor	With pulse sensor	With lock sensor	With PWM control function and pulse sensor			
	109E5712F501	109E5712F502	109E5712F501	—			
109E5712H501	☺ 109E5712H502	☺ 109E5712H501	109E5712H5D01	—	∅172 × 150 × 51 mm	No	212
109E5712K501	109E5712K502	☺ 109E5712K501	109E5712K5D01	109E5712P5K04	∅172 × 150 × 51 mm	No	212
109E5712M501	109E5712M502	109E5712M501	109E5712M5D01	—	∅172 × 150 × 51 mm	No	212
109E5712Y501	109E5712Y502	109E5712Y501	—	—	∅172 × 150 × 51 mm	No	212
109E5724C501	☺ 109E5724C502	☺ 109E5724C501	☺ 109E5724C5D01	9EH5724P5C01	∅172 × 150 × 51 mm	No	212
109E5724F501	109E5724F502	109E5724F501	—	—	∅172 × 150 × 51 mm	No	212
109E5724H501	☺ 109E5724H502	☺ 109E5724H501	☺ 109E5724H5D01	—	∅172 × 150 × 51 mm	No	212
109E5724K501	☺ 109E5724K502	☺ 109E5724K501	109E5724K5D01	—	∅172 × 150 × 51 mm	No	212
109E5724M501	☺ 109E5724M502	☺ 109E5724M501	—	—	∅172 × 150 × 51 mm	No	212
109E5748C501	109E5748C502	109E5748C501	—	—	∅172 × 150 × 51 mm	No	212
109E5748F501	109E5748F502	109E5748F501	—	—	∅172 × 150 × 51 mm	No	212
109E5748H501	109E5748H502	☺ 109E5748H501	109E5748H5D01	—	∅172 × 150 × 51 mm	No	212
109E5748K501	☺ 109E5748K502	☺ 109E5748K501	—	—	∅172 × 150 × 51 mm	No	212
109E5748M501	109E5748M502	109E5748M501	—	—	∅172 × 150 × 51 mm	No	212
109L1712H501	109L1712H502	109L1712H501	109L1712H5D01	—	∅172 × 51 mm	No	440
109L1712M501	109L1712M502	109L1712M501	109L1712M5D01	—	∅172 × 51 mm	No	440
109L1724H501	109L1724H502	109L1724H501	109L1724H5D01	—	∅172 × 51 mm	No	440
109L1724M501	109L1724M502	109L1724M501	109L1724M5D01	—	∅172 × 51 mm	No	440
109L1748H501	109L1748H502	109L1748H501	109L1748H5D01	—	∅172 × 51 mm	No	440
109L1748M501	109L1748M502	109L1748M501	109L1748M5D01	—	∅172 × 51 mm	No	440
109L5712H501	109L5712H502	109L5712H501	109L5712H5D01	—	∅172 × 150 × 51 mm	No	438
109L5712M501	109L5712M502	109L5712M501	109L5712M5D01	—	∅172 × 150 × 51 mm	No	438
109L5724H501	109L5724H502	109L5724H501	109L5724H5D01	—	∅172 × 150 × 51 mm	No	438
109L5724M501	109L5724M502	109L5724M501	109L5724M5D01	—	∅172 × 150 × 51 mm	No	438
109L5748H501	109L5748H502	109L5748H501	109L5748H5D01	—	∅172 × 150 × 51 mm	No	438
109L5748M501	109L5748M502	109L5748M501	109L5748M5D01	—	∅172 × 150 × 51 mm	No	438
109P0405F3013	109P0405F3023	☺ 109P0405F3013	☺ 109P0405F3D013	—	40 × 40 × 28 mm	Yes	53
109P0405F601	☺ 109P0405F602	☺ 109P0405F601	☺ 109P0405F6D01	—	40 × 40 × 20 mm	Yes	34
109P0405H3013	☺ 109P0405H3023	☺ 109P0405H3013	☺ 109P0405H3D013	—	40 × 40 × 28 mm	Yes	53
109P0405H601	☺ 109P0405H602	☺ 109P0405H601	☺ 109P0405H6D01	—	40 × 40 × 20 mm	Yes	34
109P0405H701	☺ 109P0405H702	☺ 109P0405H701	☺ 109P0405H7D01	—	40 × 40 × 15 mm	Yes	27
109P0405H901	☺ 109P0405H902	☺ 109P0405H901	☺ 109P0405H9D01	—	40 × 40 × 10 mm	Yes	23
109P0405J601	109P0405J602	☺ 109P0405J601	—	—	40 × 40 × 20 mm	Yes	34
109P0405M601	☺ 109P0405M602	☺ 109P0405M601	☺ 109P0405M6D01	—	40 × 40 × 20 mm	Yes	34
109P0405M701	☺ 109P0405M702	☺ 109P0405M701	☺ 109P0405M7D01	—	40 × 40 × 15 mm	Yes	27
109P0405M901	☺ 109P0405M902	☺ 109P0405M901	☺ 109P0405M9D01	—	40 × 40 × 10 mm	Yes	23
109P0412B3013	☺ 109P0412B3023	☺ 109P0412B3013	☺ 109P0412B3D013	109P0412P3B013	40 × 40 × 28 mm	Yes	53
109P0412D601	☺ 109P0412D602	☺ 109P0412D601	☺ 109P0412D6D01	—	40 × 40 × 20 mm	Yes	34
109P0412E601	☺ 109P0412E602	☺ 109P0412E601	☺ 109P0412E6D01	—	40 × 40 × 20 mm	Yes	34
109P0412F3013	☺ 109P0412F3023	☺ 109P0412F3013	☺ 109P0412F3D013	—	40 × 40 × 28 mm	Yes	53
109P0412F601	☺ 109P0412F602	☺ 109P0412F601	☺ 109P0412F6D01	—	40 × 40 × 20 mm	Yes	34
109P0412G3013	☺ 109P0412G3023	☺ 109P0412G3013	☺ 109P0412G3D013	—	40 × 40 × 28 mm	Yes	53
109P0412G601	☺ 109P0412G602	☺ 109P0412G601	☺ 109P0412G6D01	—	40 × 40 × 20 mm	Yes	34
109P0412H3013	☺ 109P0412H3023	☺ 109P0412H3013	☺ 109P0412H3D013	109P0412P3H013	40 × 40 × 28 mm	Yes	53
109P0412H601	☺ 109P0412H602	☺ 109P0412H601	☺ 109P0412H6D01	—	40 × 40 × 20 mm	Yes	34
109P0412H701	☺ 109P0412H702	☺ 109P0412H701	☺ 109P0412H7D01	—	40 × 40 × 15 mm	Yes	27
109P0412H901	☺ 109P0412H902	☺ 109P0412H901	☺ 109P0412H9D01	109P0412P9H01	40 × 40 × 10 mm	Yes	23
109P0412J3013	☺ 109P0412J3023	☺ 109P0412J3013	☺ 109P0412J3D013	9PH0412P3J013	40 × 40 × 28 mm	Yes	53
109P0412K3013	☺ 109P0412K3023	☺ 109P0412K3013	☺ 109P0412K3D013	9PH0412P3K033	40 × 40 × 28 mm	Yes	53
109P0412M3013	☺ 109P0412M3023	☺ 109P0412M3013	☺ 109P0412M3D013	—	40 × 40 × 28 mm	Yes	53
109P0412M601	☺ 109P0412M602	☺ 109P0412M601	109P0412M6D01	—	40 × 40 × 20 mm	Yes	34
109P0412M701	☺ 109P0412M702	☺ 109P0412M701	☺ 109P0412M7D01	—	40 × 40 × 15 mm	Yes	27
109P0412M901	☺ 109P0412M902	☺ 109P0412M901	☺ 109P0412M9D01	—	40 × 40 × 10 mm	Yes	23
109P0412R701	109P0412R702	☺ 109P0412R701	109P0412R7D01	—	40 × 40 × 15 mm	Yes	27
109P0412S701	☺ 109P0412S702	☺ 109P0412S701	☺ 109P0412S7D01	—	40 × 40 × 15 mm	Yes	27
109P0424B3013	109P0424B3023	☺ 109P0424B3013	☺ 109P0424B3D013	—	40 × 40 × 28 mm	Yes	53
109P0424B601	☺ 109P0424B602	☺ 109P0424B601	☺ 109P0424B6D01	—	40 × 40 × 20 mm	Yes	34
109P0424D601	☺ 109P0424D602	☺ 109P0424D601	☺ 109P0424D6D01	—	40 × 40 × 20 mm	Yes	34
109P0424F3013	☺ 109P0424F3023	☺ 109P0424F3013	☺ 109P0424F3D013	—	40 × 40 × 28 mm	Yes	53
109P0424F601	☺ 109P0424F602	☺ 109P0424F601	☺ 109P0424F6D01	—	40 × 40 × 20 mm	Yes	34

Note 1: For compliance with standards, see individual product pages. Please contact your point of sale regarding low-speed sensors.

Note 2: The ☺ mark indicates Short Lead Time Service applicable models. See p. 654 for details.

Models listed in product pages	List of models (Below are optional models and not listed in product pages. Standard compliance of these optional models may differ from that of the models listed in product pages. Contact us for details of "—" models.)				Frame size	Rib	page
	Without sensor	With pulse sensor	With lock sensor	With PWM control function and pulse sensor			
	109P0424G3013	▶▶ 109P0424G3023	▶▶ 109P0424G3013	109P0424G3D013			
109P0424G601	109P0424G602	▶▶ 109P0424G601	109P0424G6D01	—	40 × 40 × 20 mm	Yes	34
109P0424H3013	▶▶ 109P0424H3023	▶▶ 109P0424H3013	▶▶ 109P0424H3D013	—	40 × 40 × 28 mm	Yes	53
109P0424H601	▶▶ 109P0424H602	▶▶ 109P0424H601	▶▶ 109P0424H6D01	—	40 × 40 × 20 mm	Yes	34
109P0424H901	109P0424H902	109P0424H901	109P0424H9D01	—	40 × 40 × 10 mm	Yes	23
109P0424H701	▶▶ 109P0424H702	▶▶ 109P0424H701	▶▶ 109P0424H7D01	—	40 × 40 × 15 mm	Yes	27
109P0424J3013	▶▶ 109P0424J3023	▶▶ 109P0424J3013	▶▶ 109P0424J3D013	—	40 × 40 × 28 mm	Yes	53
109P0424R3013	109P0424R3023	109P0424R3013	—	—	40 × 40 × 28 mm	Yes	53
109P0505M701	▶▶ 109P0505M702	▶▶ 109P0505M701	▶▶ 109P0505M7D01	—	52 × 52 × 15 mm	Yes	60
109P0812C601	109P0812C602	109P0812C601	109P0812C6D01	—	80 × 80 × 20 mm	Yes	101
109P0812H601	▶▶ 109P0812H602	▶▶ 109P0812H601	▶▶ 109P0812H6D01	—	80 × 80 × 20 mm	Yes	101
109P0812H701	▶▶ 109P0812H702	▶▶ 109P0812H701	▶▶ 109P0812H7D01	—	80 × 80 × 15 mm	Yes	96
109P0812M601	▶▶ 109P0812M602	▶▶ 109P0812M601	▶▶ 109P0812M6D01	—	80 × 80 × 20 mm	Yes	101
109P0812M701	▶▶ 109P0812M702	▶▶ 109P0812M701	▶▶ 109P0812M7D01	—	80 × 80 × 15 mm	Yes	96
109P0824H601	▶▶ 109P0824H602	▶▶ 109P0824H601	▶▶ 109P0824H6D01	—	80 × 80 × 20 mm	Yes	101
109P0824H701	▶▶ 109P0824H702	▶▶ 109P0824H701	▶▶ 109P0824H7D01	—	80 × 80 × 15 mm	Yes	96
109P0824M601	▶▶ 109P0824M602	▶▶ 109P0824M601	▶▶ 109P0824M6D01	—	80 × 80 × 20 mm	Yes	101
109P0824M701	▶▶ 109P0824M702	▶▶ 109P0824M701	109P0824M7D01	—	80 × 80 × 15 mm	Yes	96
109P0848C601	109P0848C602	109P0848C601	109P0848C6D01	—	80 × 80 × 20 mm	Yes	101
109P0848H601	—	109P0848H601	109P0848H6D01	—	80 × 80 × 20 mm	Yes	101
109P1312H101	109P1312H102	109P1312H101	109P1312H1D01	—	127 × 127 × 38 mm	Yes	192
109P1312H1011	109P1312H1021	109P1312H1011	109P1312H1D011	—	127 × 127 × 38 mm	No	192
109P1312S101	109P1312S102	109P1312S101	109P1312S1D01	—	127 × 127 × 38 mm	Yes	192
109P1312S1011	109P1312S1021	109P1312S1011	109P1312S1D011	—	127 × 127 × 38 mm	No	192
109P1324H101	109P1324H102	109P1324H101	109P1324H1D01	—	127 × 127 × 38 mm	Yes	192
109P1324H1011	109P1324H1021	109P1324H1011	109P1324H1D011	—	127 × 127 × 38 mm	No	192
109P1324S101	109P1324S102	109P1324S101	109P1324S1D01	—	127 × 127 × 38 mm	Yes	192
109P1324S1011	109P1324S1021	109P1324S1011	109P1324S1D011	—	127 × 127 × 38 mm	No	192
109P1348H101	109P1348H102	109P1348H101	109P1348H1D01	—	127 × 127 × 38 mm	Yes	192
109P1348H1011	109P1348H1021	109P1348H1011	109P1348H1D011	—	127 × 127 × 38 mm	No	192
109P1348S101	109P1348S102	109P1348S101	109P1348S1D01	—	127 × 127 × 38 mm	Yes	192
109P1348S1011	109P1348S1021	109P1348S1011	109P1348S1D011	—	127 × 127 × 38 mm	No	192
109P1412H101	109P1412H102	109P1412H101	109P1412H1D01	—	140 × 140 × 38 mm	Yes	198
109P1412M101	109P1412M102	109P1412M101	—	—	140 × 140 × 38 mm	Yes	198
109P1424H101	109P1424H102	109P1424H101	109P1424H1D01	—	140 × 140 × 38 mm	Yes	198
109P1424M101	109P1424M102	109P1424M101	—	—	140 × 140 × 38 mm	Yes	198
109P1448H101	109P1448H102	109P1448H101	—	—	140 × 140 × 38 mm	Yes	198
109P1448M101	109P1448M102	109P1448M101	—	—	140 × 140 × 38 mm	Yes	198
109R0605F401	▶▶ 109R0605F402	▶▶ 109R0605F401	▶▶ 109R0605F4D01	—	60 × 60 × 25 mm	Yes	74
109R0605F4011	109R0605F4021	109R0605F4011	—	—	60 × 60 × 25 mm	No	74
109R0605H401	▶▶ 109R0605H402	▶▶ 109R0605H401	▶▶ 109R0605H4D01	—	60 × 60 × 25 mm	Yes	74
109R0605H4011	109R0605H4021	109R0605H4011	—	—	60 × 60 × 25 mm	No	74
109R0605M401	▶▶ 109R0605M402	▶▶ 109R0605M401	▶▶ 109R0605M4D01	—	60 × 60 × 25 mm	Yes	74
109R0605M4011	109R0605M4021	109R0605M4011	—	—	60 × 60 × 25 mm	No	74
109R0612D401	▶▶ 109R0612D402	▶▶ 109R0612D401	▶▶ 109R0612D4D01	—	60 × 60 × 25 mm	Yes	74
109R0612D4011	109R0612D4021	109R0612D4011	109R0612D4D011	—	60 × 60 × 25 mm	No	74
109R0612F401	109R0612F402	▶▶ 109R0612F401	▶▶ 109R0612F4D01	—	60 × 60 × 25 mm	Yes	74
109R0612F4011	109R0612F4021	109R0612F4011	109R0612F4D011	—	60 × 60 × 25 mm	No	74
109R0612G401	▶▶ 109R0612G402	▶▶ 109R0612G401	▶▶ 109R0612G4D01	—	60 × 60 × 25 mm	Yes	74
109R0612G4011	109R0612G4021	▶▶ 109R0612G4011	109R0612G4D011	—	60 × 60 × 25 mm	No	74
109R0612H401	▶▶ 109R0612H402	▶▶ 109R0612H401	▶▶ 109R0612H4D01	—	60 × 60 × 25 mm	Yes	74
109R0612H4011	109R0612H4021	▶▶ 109R0612H4011	▶▶ 109R0612H4D011	—	60 × 60 × 25 mm	No	74
109R0612J401	▶▶ 109R0612J402	▶▶ 109R0612J401	▶▶ 109R0612J4D01	109R0612P4J03	60 × 60 × 25 mm	Yes	74
109R0612J4011	▶▶ 109R0612J4021	109R0612J4011	109R0612J4D011	109R0612P4J061	60 × 60 × 25 mm	No	74
109R0612M401	▶▶ 109R0612M402	▶▶ 109R0612M401	▶▶ 109R0612M4D01	—	60 × 60 × 25 mm	Yes	74
109R0612M4011	109R0612M4021	109R0612M4011	109R0612M4D011	—	60 × 60 × 25 mm	No	74
109R0612S401	▶▶ 109R0612S402	▶▶ 109R0612S401	▶▶ 109R0612S4D01	—	60 × 60 × 25 mm	Yes	74
109R0612S4011	109R0612S4021	109R0612S4011	▶▶ 109R0612S4D011	—	60 × 60 × 25 mm	No	74
109R0624D401	▶▶ 109R0624D402	▶▶ 109R0624D401	▶▶ 109R0624D4D01	—	60 × 60 × 25 mm	Yes	74
109R0624D4011	109R0624D4021	109R0624D4011	—	—	60 × 60 × 25 mm	No	74
109R0624F401	▶▶ 109R0624F402	▶▶ 109R0624F401	▶▶ 109R0624F4D01	—	60 × 60 × 25 mm	Yes	74

Note 1: For compliance with standards, see individual product pages. Please contact your point of sale regarding low-speed sensors.

Note 2: The ▶▶ mark indicates Short Lead Time Service applicable models. See p. 654 for details.

Models listed in product pages	List of models (Below are optional models and not listed in product pages. Standard compliance of these optional models may differ from that of the models listed in product pages. Contact us for details of "-" models.)				Frame size	Rib	page
	Without sensor	With pulse sensor	With lock sensor	With PWM control function and pulse sensor			
	109R0624F4011	109R0624F4021	109R0624F4011	109R0624F4D011			
109R0624G401	☛ 109R0624G402	☛ 109R0624G401	☛ 109R0624G4D01	—	60 × 60 × 25 mm	Yes	74
109R0624G4011	☛ 109R0624G4021	109R0624G4011	109R0624G4D011	—	60 × 60 × 25 mm	No	74
109R0624H401	☛ 109R0624H402	☛ 109R0624H401	☛ 109R0624H4D01	—	60 × 60 × 25 mm	Yes	74
109R0624H4011	☛ 109R0624H4021	109R0624H4011	☛ 109R0624H4D011	—	60 × 60 × 25 mm	No	74
109R0624J401	☛ 109R0624J402	☛ 109R0624J401	☛ 109R0624J4D01	9RH0624P4J01	60 × 60 × 25 mm	Yes	74
109R0624J4011	109R0624J4021	109R0624J4011	109R0624J4D011	—	60 × 60 × 25 mm	No	74
109R0624M401	☛ 109R0624M402	☛ 109R0624M401	109R0624M4D01	—	60 × 60 × 25 mm	Yes	74
109R0624M4011	109R0624M4021	109R0624M4011	109R0624M4D011	—	60 × 60 × 25 mm	No	74
109R0624S401	☛ 109R0624S402	☛ 109R0624S401	☛ 109R0624S4D01	—	60 × 60 × 25 mm	Yes	74
109R0624S4011	☛ 109R0624S4021	109R0624S4011	109R0624S4D011	—	60 × 60 × 25 mm	No	74
109R0648G401	☛ 109R0648G402	☛ 109R0648G401	☛ 109R0648G4D01	—	60 × 60 × 25 mm	Yes	74
109R0648G4011	109R0648G4021	109R0648G4011	109R0648G4D011	—	60 × 60 × 25 mm	No	74
109R0648H401	☛ 109R0648H402	☛ 109R0648H401	☛ 109R0648H4D01	—	60 × 60 × 25 mm	Yes	74
109R0648H4011	109R0648H4021	109R0648H4011	109R0648H4D011	—	60 × 60 × 25 mm	No	74
109R0648J401	☛ 109R0648J402	☛ 109R0648J401	☛ 109R0648J4D01	—	60 × 60 × 25 mm	Yes	74
109R0648J4011	109R0648J4021	109R0648J4011	—	—	60 × 60 × 25 mm	No	74
109R0805F401	☛ 109R0805F402	☛ 109R0805F401	☛ 109R0805F4D01	—	80 × 80 × 25 mm	Yes	109
109R0805F4011	☛ 109R0805F4021	109R0805F4011	—	—	80 × 80 × 25 mm	No	109
109R0805M401	☛ 109R0805M402	☛ 109R0805M401	☛ 109R0805M4D01	—	80 × 80 × 25 mm	Yes	109
109R0805M4011	☛ 109R0805M4021	109R0805M4011	—	—	80 × 80 × 25 mm	No	109
109R0812E401	109R0812E402	☛ 109R0812E401	—	—	80 × 80 × 25 mm	Yes	109
109R0812E4011	—	109R0812E4011	—	—	80 × 80 × 25 mm	No	109
109R0812F401	☛ 109R0812F402	☛ 109R0812F401	☛ 109R0812F4D01	—	80 × 80 × 25 mm	Yes	109
109R0812F4011	☛ 109R0812F4021	☛ 109R0812F4011	109R0812F4D011	—	80 × 80 × 25 mm	No	109
109R0812G401	☛ 109R0812G402	☛ 109R0812G401	☛ 109R0812G4D01	—	80 × 80 × 25 mm	Yes	109
109R0812G4011	☛ 109R0812G4021	☛ 109R0812G4011	☛ 109R0812G4D011	—	80 × 80 × 25 mm	No	109
109R0812H401	☛ 109R0812H402	☛ 109R0812H401	☛ 109R0812H4D01	—	80 × 80 × 25 mm	Yes	109
109R0812H4011	☛ 109R0812H4021	☛ 109R0812H4011	☛ 109R0812H4D011	—	80 × 80 × 25 mm	No	109
109R0812L401	☛ 109R0812L402	☛ 109R0812L401	☛ 109R0812L4D01	—	80 × 80 × 25 mm	Yes	109
109R0812L4011	☛ 109R0812L4021	☛ 109R0812L4011	109R0812L4D011	—	80 × 80 × 25 mm	No	109
109R0812M401	☛ 109R0812M402	☛ 109R0812M401	☛ 109R0812M4D01	—	80 × 80 × 25 mm	Yes	109
109R0812M4011	☛ 109R0812M4021	☛ 109R0812M4011	109R0812M4D011	—	80 × 80 × 25 mm	No	109
109R0812S401	☛ 109R0812S402	☛ 109R0812S401	☛ 109R0812S4D01	—	80 × 80 × 25 mm	Yes	109
109R0812S4011	☛ 109R0812S4021	☛ 109R0812S4011	☛ 109R0812S4D011	—	80 × 80 × 25 mm	No	109
109R0824F401	☛ 109R0824F402	☛ 109R0824F401	☛ 109R0824F4D01	—	80 × 80 × 25 mm	Yes	109
109R0824F4011	109R0824F4021	109R0824F4011	109R0824F4D011	—	80 × 80 × 25 mm	No	109
109R0824G401	☛ 109R0824G402	☛ 109R0824G401	☛ 109R0824G4D01	—	80 × 80 × 25 mm	Yes	109
109R0824G4011	☛ 109R0824G4021	109R0824G4011	☛ 109R0824G4D011	—	80 × 80 × 25 mm	No	109
109R0824H401	☛ 109R0824H402	☛ 109R0824H401	☛ 109R0824H4D01	—	80 × 80 × 25 mm	Yes	109
109R0824H4011	☛ 109R0824H4021	☛ 109R0824H4011	☛ 109R0824H4D011	—	80 × 80 × 25 mm	No	109
109R0824L401	☛ 109R0824L402	☛ 109R0824L401	☛ 109R0824L4D01	—	80 × 80 × 25 mm	Yes	109
109R0824L4011	☛ 109R0824L4021	☛ 109R0824L4011	109R0824L4D011	—	80 × 80 × 25 mm	No	109
109R0824M401	☛ 109R0824M402	☛ 109R0824M401	☛ 109R0824M4D01	—	80 × 80 × 25 mm	Yes	109
109R0824M4011	☛ 109R0824M4021	☛ 109R0824M4011	109R0824M4D011	—	80 × 80 × 25 mm	No	109
109R0824S401	☛ 109R0824S402	☛ 109R0824S401	☛ 109R0824S4D01	—	80 × 80 × 25 mm	Yes	109
109R0824S4011	☛ 109R0824S4021	☛ 109R0824S4011	☛ 109R0824S4D011	—	80 × 80 × 25 mm	No	109
109R0848K401	☛ 109R0848K402	☛ 109R0848K401	☛ 109R0848K4D01	—	80 × 80 × 25 mm	Yes	109
109R0848K4011	109R0848K4021	109R0848K4011	109R0848K4D011	—	80 × 80 × 25 mm	No	109
109R0848S401	☛ 109R0848S402	☛ 109R0848S401	☛ 109R0848S4D01	—	80 × 80 × 25 mm	Yes	109
109R0848S4011	109R0848S4021	109R0848S4011	109R0848S4D011	—	80 × 80 × 25 mm	No	109
9A0612F401	9A0612F402	9A0612F401	9A0612F4D01	—	60 × 60 × 25 mm	Yes	80
9A0612F4011	9A0612F4021	9A0612F4011	9A0612F4D011	—	60 × 60 × 25 mm	No	80
9A0612G401	☛ 9A0612G402	☛ 9A0612G401	9A0612G4D01	9AH0612P4G03	60 × 60 × 25 mm	Yes	80
9A0612G4011	9A0612G4021	9A0612G4011	9A0612G4D011	—	60 × 60 × 25 mm	No	80
9A0612H401	☛ 9A0612H402	☛ 9A0612H401	9A0612H4D01	9AH0612P4H05	60 × 60 × 25 mm	Yes	80
9A0612H4011	9A0612H4021	9A0612H4011	9A0612H4D011	—	60 × 60 × 25 mm	No	80
9A0612M401	9A0612M402	9A0612M401	9A0612M4D01	—	60 × 60 × 25 mm	Yes	80
9A0612M4011	9A0612M4021	9A0612M4011	9A0612M4D011	—	60 × 60 × 25 mm	No	80
9A0612S401	☛ 9A0612S402	☛ 9A0612S401	9A0612S4D01	—	60 × 60 × 25 mm	Yes	80
9A0612S4011	9A0612S4021	9A0612S4011	9A0612S4D011	9AH0612P4S011	60 × 60 × 25 mm	No	80

Note 1: For compliance with standards, see individual product pages. Please contact your point of sale regarding low-speed sensors.

Note 2: The ☛ mark indicates Short Lead Time Service applicable models. See p. 654 for details.

Models listed in product pages	List of models (Below are optional models and not listed in product pages. Standard compliance of these optional models may differ from that of the models listed in product pages. Contact us for details of "—" models.)				Frame size	Rib	page
	Without sensor	With pulse sensor	With lock sensor	With PWM control function and pulse sensor			
	9A0624F401	9A0624F402	9A0624F401	9A0624F4D01			
9A0624F4011	9A0624F4021	9A0624F4011	9A0624F4D011	—	60 × 60 × 25 mm	No	80
9A0624G401	9A0624G402	9A0624G401	9A0624G4D01	—	60 × 60 × 25 mm	Yes	80
9A0624G4011	9A0624G4021	9A0624G4011	—	—	60 × 60 × 25 mm	No	80
9A0624H401	9A0624H402	9A0624H401	9A0624H4D01	—	60 × 60 × 25 mm	Yes	80
9A0624H4011	9A0624H4021	9A0624H4011	9A0624H4D011	—	60 × 60 × 25 mm	No	80
9A0624M401	9A0624M402	9A0624M401	9A0624M4D01	—	60 × 60 × 25 mm	Yes	80
9A0624M4011	9A0624M4021	9A0624M4011	9A0624M4D011	—	60 × 60 × 25 mm	No	80
9A0624S401	9A0624S402	9A0624S401	9A0624S4D01	—	60 × 60 × 25 mm	Yes	80
9A0624S4011	9A0624S4021	9A0624S4011	9A0624S4D011	—	60 × 60 × 25 mm	No	80
9A0812F401	9A0812F402	9A0812F401	9A0812F4D01	—	80 × 80 × 25 mm	Yes	114
9A0812F4011	9A0812F4021	9A0812F4011	9A0812F4D011	—	80 × 80 × 25 mm	No	114
9A0812G401	9A0812G402	9A0812G401	9A0812G4D01	9AH0812P4G04	80 × 80 × 25 mm	Yes	114
9A0812G4011	9A0812G4021	9A0812G4011	9A0812G4D011	9AH0812P4G011	80 × 80 × 25 mm	No	114
9A0812H401	9A0812H402	9A0812H401	9A0812H4D01	9AH0812P4H04	80 × 80 × 25 mm	Yes	114
9A0812H4011	9A0812H4021	9A0812H4011	9A0812H4D011	—	80 × 80 × 25 mm	No	114
9A0812L401	9A0812L402	9A0812L401	9A0812L4D01	—	80 × 80 × 25 mm	Yes	114
9A0812L4011	9A0812L4021	9A0812L4011	9A0812L4D011	—	80 × 80 × 25 mm	No	114
9A0812M401	9A0812M402	9A0812M401	9A0812M4D01	—	80 × 80 × 25 mm	Yes	114
9A0812M4011	9A0812M4021	9A0812M4011	9A0812M4D011	—	80 × 80 × 25 mm	No	114
9A0812S401	9A0812S402	9A0812S401	9A0812S4D01	—	80 × 80 × 25 mm	Yes	114
9A0812S4011	9A0812S4021	9A0812S4011	9A0812S4D011	—	80 × 80 × 25 mm	No	114
9A0824F401	9A0824F402	9A0824F401	9A0824F4D01	—	80 × 80 × 25 mm	Yes	114
9A0824F4011	9A0824F4021	9A0824F4011	9A0824F4D011	—	80 × 80 × 25 mm	No	114
9A0824G401	9A0824G402	9A0824G401	9A0824G4D01	—	80 × 80 × 25 mm	Yes	114
9A0824G4011	9A0824G4021	9A0824G4011	9A0824G4D011	—	80 × 80 × 25 mm	No	114
9A0824H401	9A0824H402	9A0824H401	9A0824H4D01	—	80 × 80 × 25 mm	Yes	114
9A0824H4011	9A0824H4021	9A0824H4011	9A0824H4D011	—	80 × 80 × 25 mm	No	114
9A0824L401	9A0824L402	9A0824L401	9A0824L4D01	—	80 × 80 × 25 mm	Yes	114
9A0824L4011	9A0824L4021	9A0824L4011	9A0824L4D011	—	80 × 80 × 25 mm	No	114
9A0824M401	9A0824M402	9A0824M401	9A0824M4D01	—	80 × 80 × 25 mm	Yes	114
9A0824M4011	9A0824M4021	9A0824M4011	9A0824M4D011	—	80 × 80 × 25 mm	No	114
9A0824S401	9A0824S402	9A0824S401	9A0824S4D01	—	80 × 80 × 25 mm	Yes	114
9A0824S4011	9A0824S4021	9A0824S4011	9A0824S4D011	—	80 × 80 × 25 mm	No	114
9A0912F401	9A0912F402	9A0912F401	9A0912F4D01	—	92 × 92 × 25 mm	Yes	147
9A0912F4011	9A0912F4021	9A0912F4011	9A0912F4D011	—	92 × 92 × 25 mm	No	147
9A0912G401	9A0912G402	9A0912G401	9A0912G4D01	9AH0912P4G03	92 × 92 × 25 mm	Yes	147
9A0912G4011	9A0912G4021	9A0912G4011	9A0912G4D011	—	92 × 92 × 25 mm	No	147
9A0912H401	9A0912H402	9A0912H401	9A0912H4D01	9AH0912P4H03	92 × 92 × 25 mm	Yes	147
9A0912H4011	9A0912H4021	9A0912H4011	9A0912H4D011	—	92 × 92 × 25 mm	No	147
9A0912L401	9A0912L402	9A0912L401	9A0912L4D01	—	92 × 92 × 25 mm	Yes	147
9A0912L4011	9A0912L4021	9A0912L4011	9A0912L4D011	—	92 × 92 × 25 mm	No	147
9A0912M401	9A0912M402	9A0912M401	9A0912M4D01	—	92 × 92 × 25 mm	Yes	147
9A0912M4011	9A0912M4021	9A0912M4011	9A0912M4D011	—	92 × 92 × 25 mm	No	147
9A0912S401	9A0912S402	9A0912S401	9A0912S4D01	—	92 × 92 × 25 mm	Yes	147
9A0912S4011	9A0912S4021	9A0912S4011	9A0912S4D011	—	92 × 92 × 25 mm	No	147
9A0924F401	9A0924F402	9A0924F401	9A0924F4D01	—	92 × 92 × 25 mm	Yes	147
9A0924F4011	9A0924F4021	9A0924F4011	9A0924F4D011	—	92 × 92 × 25 mm	No	147
9A0924G401	9A0924G402	9A0924G401	9A0924G4D01	—	92 × 92 × 25 mm	Yes	147
9A0924G4011	9A0924G4021	9A0924G4011	—	—	92 × 92 × 25 mm	No	147
9A0924H401	9A0924H402	9A0924H401	9A0924H4D01	—	92 × 92 × 25 mm	Yes	147
9A0924H4011	9A0924H4021	9A0924H4011	9A0924H4D011	—	92 × 92 × 25 mm	No	147
9A0924L401	9A0924L402	9A0924L401	9A0924L4D01	—	92 × 92 × 25 mm	Yes	147
9A0924L4011	9A0924L4021	9A0924L4011	9A0924L4D011	—	92 × 92 × 25 mm	No	147
9A0924M401	9A0924M402	9A0924M401	9A0924M4D01	—	92 × 92 × 25 mm	Yes	147
9A0924M4011	9A0924M4021	9A0924M4011	9A0924M4D011	—	92 × 92 × 25 mm	No	147
9A0924S401	9A0924S402	9A0924S401	9A0924S4D01	—	92 × 92 × 25 mm	Yes	147
9A0924S4011	9A0924S4021	9A0924S4011	9A0924S4D011	—	92 × 92 × 25 mm	No	147
9A0948S401	9A0948S402	9A0948S401	9A0948S4D01	—	92 × 92 × 25 mm	Yes	147
9A0948S4011	9A0948S4021	9A0948S4011	—	—	92 × 92 × 25 mm	No	147
9B1TP24P0H001	—	—	—	9B1TP24P0H001	270 × 270 × 99 mm	—	485

Note 1: For compliance with standards, see individual product pages. Please contact your point of sale regarding low-speed sensors.

Note 2: The  mark indicates Short Lead Time Service applicable models. See p. 654 for details.

Models listed in product pages	List of models (Below are optional models and not listed in product pages. Standard compliance of these optional models may differ from that of the models listed in product pages. Contact us for details of "–" models.)				Frame size	Rib	page
	Without sensor	With pulse sensor	With lock sensor	With PWM control function and pulse sensor			
	9B1TP48P0G001	–	–	–			
9B1TP48P0H001	–	–	–	9B1TP48P0H001	270 × 270 × 99 mm	–	485
9B1TS48P0G001	–	–	–	9B1TS48P0G001	270 × 270 × 119 mm	–	488
9B1TS48P0H001	–	–	–	9B1TS48P0H001	270 × 270 × 119 mm	–	488
9B1W2TP24P0H001	–	–	–	9B1W2TP24P0H001	270 × 270 × 99 mm	–	353
9B1W2TP48P0S001	–	–	–	9B1W2TP48P0S001	270 × 270 × 99 mm	–	353
9B1W2TS48P0S001	–	–	–	9B1W2TS48P0S001	270 × 270 × 119 mm	–	356
9BD12FC6-1	9BD12FA6-1	▶▶ 9BD12FC6-1	9BD12FD6-1	–	76 × 20 mm	–	494
9BD12HC6-1	▶▶ 9BD12HA6-1	▶▶ 9BD12HC6-1	9BD12HD6-1	–	76 × 20 mm	–	494
9BD12SC6-1	9BD12SA6-1	▶▶ 9BD12SC6-1	▶▶ 9BD12SD6-1	9BD12P6S01	76 × 20 mm	–	494
9BD24FC6-1	9BD24FA6-1	▶▶ 9BD24FC6-1	9BD24FD6-1	–	76 × 20 mm	–	494
9BD24HC6-1	▶▶ 9BD24HA6-1	▶▶ 9BD24HC6-1	9BD24HD6-1	–	76 × 20 mm	–	494
9BD24SC6-1	▶▶ 9BD24SA6-1	▶▶ 9BD24SC6-1	▶▶ 9BD24SD6-1	9BD24P6S06	76 × 20 mm	–	494
9BFB12P2H003	–	–	–	▶▶ 9BFB12P2H003	120 × 32 mm	–	508
9BFB24P2H003	–	–	9BFB24H2D001	▶▶ 9BFB24P2H003	120 × 32 mm	–	508
9BMB12F201	9BMB12F202	▶▶ 9BMB12F201	9BMB12F2D01	▶▶ 9BMB12P2F01	97 × 33 mm	–	500
9BMB12G201	9BMB12G202	▶▶ 9BMB12G201	9BMB12G2D01	▶▶ 9BMB12P2G01	97 × 33 mm	–	500
9BMB12H201	▶▶ 9BMB12H202	▶▶ 9BMB12H201	▶▶ 9BMB12H2D01	▶▶ 9BMB12P2H01	97 × 33 mm	–	500
9BMB12K201	▶▶ 9BMB12K202	▶▶ 9BMB12K201	–	▶▶ 9BMB12P2K01	97 × 33 mm	–	500
9BMB12P2F01	9BMB12F202	▶▶ 9BMB12F201	9BMB12F2D01	▶▶ 9BMB12P2F01	97 × 33 mm	–	500
9BMB12P2G01	9BMB12G202	▶▶ 9BMB12G201	9BMB12G2D01	▶▶ 9BMB12P2G01	97 × 33 mm	–	500
9BMB12P2H01	▶▶ 9BMB12H202	▶▶ 9BMB12H201	▶▶ 9BMB12H2D01	▶▶ 9BMB12P2H01	97 × 33 mm	–	500
9BMB12P2K01	▶▶ 9BMB12K202	▶▶ 9BMB12K201	–	▶▶ 9BMB12P2K01	97 × 33 mm	–	500
9BMB12P2S01	9BMB12S202	▶▶ 9BMB12S201	–	9BMB12P2S01	97 × 33 mm	–	500
9BMB12S201	9BMB12S202	▶▶ 9BMB12S201	–	9BMB12P2S01	97 × 33 mm	–	500
9BMB24F201	9BMB24F202	▶▶ 9BMB24F201	9BMB24F2D01	▶▶ 9BMB24P2F01	97 × 33 mm	–	500
9BMB24G201	▶▶ 9BMB24G202	▶▶ 9BMB24G201	▶▶ 9BMB24G2D01	▶▶ 9BMB24P2G01	97 × 33 mm	–	500
9BMB24H201	▶▶ 9BMB24H202	▶▶ 9BMB24H201	▶▶ 9BMB24H2D01	9BMB24P2H01	97 × 33 mm	–	500
9BMB24K201	9BMB24K202	9BMB24K201	9BMB24K2D01	▶▶ 9BMB24P2K01	97 × 33 mm	–	500
9BMB24P2F01	9BMB24F202	▶▶ 9BMB24F201	9BMB24F2D01	▶▶ 9BMB24P2F01	97 × 33 mm	–	500
9BMB24P2G01	▶▶ 9BMB24G202	▶▶ 9BMB24G201	▶▶ 9BMB24G2D01	▶▶ 9BMB24P2G01	97 × 33 mm	–	500
9BMB24P2H01	▶▶ 9BMB24H202	▶▶ 9BMB24H201	▶▶ 9BMB24H2D01	9BMB24P2H01	97 × 33 mm	–	500
9BMB24P2K01	9BMB24K202	9BMB24K201	–	▶▶ 9BMB24P2K01	97 × 33 mm	–	500
9BMB24P2S01	9BMB24S202	▶▶ 9BMB24S201	–	9BMB24P2S01	97 × 33 mm	–	500
9BMB24S201	9BMB24S202	▶▶ 9BMB24S201	–	9BMB24P2S01	97 × 33 mm	–	500
9BMC12P2G001	9BMC12G2002	–	–	▶▶ 9BMC12P2G001	97 × 33 mm	–	498
9BMC24P2G001	–	–	–	▶▶ 9BMC24P2G001	97 × 33 mm	–	498
9CR0612P5G03	9CR0612G502	9CR0612G501	–	9CR0612P5G03	60 × 60 × 51 mm	–	240
9CR0612P5H03	–	9CR0612H501	–	9CR0612P5H03	60 × 60 × 51 mm	–	240
9CR1212P0G03	9CR1212G002	9CR1212G001	–	9CR1212P0G03	120 × 120 × 76 mm	–	258
9CR5748P9G001	–	–	–	9CR5748P9G001	∅172 × 150 × 102 mm	–	260
9CRA0312P4J03	–	9CRA0312J401	–	9CRA0312P4J03	38 × 38 × 48 mm	–	224
9CRA0312P4K03	9CRA0312K402	–	–	9CRA0312P4K03	38 × 38 × 48 mm	–	224
9CRA0412P4G03	9CRA0412G402	–	–	9CRA0412P4G03	40 × 40 × 48 mm	–	226
9CRA0412P4J03	9CRA0412J402	9CRA0412J401	–	9CRA0412P4J03	40 × 40 × 48 mm	–	226
9CRA0412P4K03	9CRA0412K402	9CRA0412K401	–	9CRA0412P4K03	40 × 40 × 48 mm	–	226
9CRA0612P0G001	–	–	–	▶▶ 9CRA0612P0G001	60 × 60 × 76 mm	–	247
9CRA0612P0S001	–	–	–	9CRA0612P0S001	60 × 60 × 76 mm	–	247
9CRA0612P6G001	–	–	–	9CRA0612P6G001	60 × 60 × 56 mm	–	242
9CRA0612P6J001	–	–	–	9CRA0612P6J001	60 × 60 × 56 mm	–	242
9CRA0612P6K001	–	–	–	▶▶ 9CRA0612P6K001	60 × 60 × 56 mm	–	242
9CRA0812P8G001	–	9CRA0812G8001	–	▶▶ 9CRA0812P8G001	80 × 80 × 80 mm	–	253
9CRA0824P8G001	–	–	9CRA0824G8D001	9CRA0824P8G001	80 × 80 × 80 mm	–	253
9CRA0848P8G001	–	–	–	▶▶ 9CRA0848P8G001	80 × 80 × 80 mm	–	253
9CRA0912P0G001	–	–	–	▶▶ 9CRA0912P0G001	92 × 92 × 76 mm	–	256
9CRA0948P0G601	–	–	–	▶▶ 9CRA0948P0G601	92 × 92 × 76 mm	–	256
9CRB0812P8G001	–	–	–	▶▶ 9CRB0812P8G001	80 × 80 × 80 mm	–	249
9CRD0412P5G03	–	–	–	9CRD0412P5G03	40 × 40 × 56 mm	–	235
9CRD0412P5H03	–	–	–	9CRD0412P5H03	40 × 40 × 56 mm	–	235
9CRD0412P5J03	–	–	–	9CRD0412P5J03	40 × 40 × 56 mm	–	235
9CRD0412P5M03	–	–	–	9CRD0412P5M03	40 × 40 × 56 mm	–	235

Note 1: For compliance with standards, see individual product pages. Please contact your point of sale regarding low-speed sensors.

Note 2: The ▶▶ mark indicates Short Lead Time Service applicable models. See p. 654 for details.

Models listed in product pages	List of models (Below are optional models and not listed in product pages. Standard compliance of these optional models may differ from that of the models listed in product pages. Contact us for details of "-" models.)				Frame size	Rib	page
	Without sensor	With pulse sensor	With lock sensor	With PWM control function and pulse sensor			
	9CRE0412P5J03	9CRE0412J502	—	—			
9CRE0612P0G001	—	—	—	9CRE0612P0G001	60 × 60 × 76 mm	—	245
9CRE0812P8G001	—	—	—	9CRE0812P8G001	80 × 80 × 80 mm	—	251
9CRH0412P5J001	—	—	—	9CRH0412P5J001	40 × 40 × 56 mm	—	231
9CRJ0412P5J001	—	—	—	9CRJ0412P5J001	40 × 40 × 56 mm	—	229
9CRL0612P0G001	—	—	—	9CRL0612P0G001	60 × 60 × 76 mm	No	403
9CRL0812P8G001	—	—	—	9CRL0812P8G001	80 × 80 × 80 mm	No	410
9CRLA0612P0G001	—	—	—	9CRLA0612P0G001	60 × 60 × 76 mm	No	401
9CRV0412P5J201	—	—	—	9CRV0412P5J201	40 × 40 × 56 mm	—	233
9EC2024H001	9EC2024H002	9EC2024H001	9EC2024H0D01	—	∅200 × 70 mm	No	220
9EC2048A001	9EC2048A002	9EC2048A001	9EC2048A0D01	9EC2048P0A01	∅200 × 70 mm	No	220
9EC2048H001	9EC2048H002	9EC2048H001	—	—	∅200 × 70 mm	No	220
9EC2048J001	9EC2048J002	9EC2048J001	—	9EC2048P0J01	∅200 × 70 mm	No	220
9G0612P4H001	9G0612H4002	—	9G0612H4D001	9G0612P4H001	60 × 60 × 25 mm	Yes	71
9G0612P4H0011	9G0612H40021	9G0612H40011	9G0612H4D0011	9G0612P4H0011	60 × 60 × 25 mm	No	71
9G0612P4S001	9G0612S4002	9G0612S4001	—	9G0612P4S001	60 × 60 × 25 mm	Yes	71
9G0612P4S0011	9G0612S40021	—	—	9G0612P4S0011	60 × 60 × 25 mm	No	71
9G0624P4F001	9G0624F4002	—	—	9G0624P4F001	60 × 60 × 25 mm	Yes	71
9G0624P4F0011	—	—	—	9G0624P4F0011	60 × 60 × 25 mm	No	71
9G0624P4H001	9G0624H4002	9G0624H4001	9G0624H4D001	9G0624P4H001	60 × 60 × 25 mm	Yes	71
9G0624P4H0011	9G0624H40021	—	—	9G0624P4H0011	60 × 60 × 25 mm	No	71
9G0624P4S001	9G0624S4002	—	9G0624S4D001	9G0624P4S001	60 × 60 × 25 mm	Yes	71
9G0624P4S0011	9G0624S40021	—	—	9G0624P4S0011	60 × 60 × 25 mm	No	71
9G0648P4S001	9G0648S4002	—	—	9G0648P4S001	60 × 60 × 25 mm	Yes	71
9G0648P4S0011	—	—	—	9G0648P4S0011	60 × 60 × 25 mm	No	71
9G0812G101	9G0812G102	9G0812G101	9G0812G1D01	9G0812P1G04	80 × 80 × 38 mm	Yes	134
9G0812G1011	9G0812G1021	9G0812G1011	9G0812G1D011	9G0812P1G081	80 × 80 × 38 mm	No	134
9G0812H101	9G0812H102	9G0812H101	9G0812H1D01	9G0812P1H03	80 × 80 × 38 mm	Yes	134
9G0812H1011	9G0812H1021	9G0812H1011	9G0812H1D011	9G0812P1H051	80 × 80 × 38 mm	No	134
9G0812K101	9G0812K102	9G0812K101	9G0812K1D01	9G0812P1K08	80 × 80 × 38 mm	Yes	134
9G0812K1011	9G0812K1021	9G0812K1011	—	9G0812P1K081	80 × 80 × 38 mm	No	134
9G0824G101	9G0824G102	9G0824G101	9G0824G1D01	9G0824P1G04	80 × 80 × 38 mm	Yes	134
9G0824G1011	9G0824G1021	9G0824G1011	9G0824G1D011	—	80 × 80 × 38 mm	No	134
9G0824H101	9G0824H102	9G0824H101	9G0824H1D01	—	80 × 80 × 38 mm	Yes	134
9G0824H1011	9G0824H1021	9G0824H1011	9G0824H1D011	—	80 × 80 × 38 mm	No	134
9G0848G101	9G0848G102	9G0848G101	9G0848G1D01	9G0848P1G03	80 × 80 × 38 mm	Yes	134
9G0848G1011	9G0848G1021	9G0848G1011	9G0848G1D011	—	80 × 80 × 38 mm	No	134
9G0848H101	9G0848H102	9G0848H101	9G0848H1D01	9G0848P1H04	80 × 80 × 38 mm	Yes	134
9G0848H1011	9G0848H1021	9G0848H1011	—	—	80 × 80 × 38 mm	No	134
9G0912A201	9G0912A202	9G0912A201	9G0912A2D01	9G0912P2A01	92 × 92 × 32 mm	Yes	150
9G0912A2011	9G0912A2021	9G0912A2011	9G0912A2D011	—	92 × 92 × 32 mm	No	150
9G0912G101	9G0912G102	9G0912G101	9G0912G1D01	9G0912P1G03	92 × 92 × 38 mm	Yes	162
9G0912G1011	9G0912G1021	9G0912G1011	—	9G0912P1G031	92 × 92 × 38 mm	No	162
9G0912H101	9G0912H102	9G0912H101	9G0912H1D01	9G0912P1H05	92 × 92 × 38 mm	Yes	162
9G0912H1011	9G0912H1021	9G0912H1011	9G0912H1D011	—	92 × 92 × 38 mm	No	162
9G0912H201	9G0912H202	9G0912H201	9G0912H2D01	9G0912P2H01	92 × 92 × 32 mm	Yes	150
9G0912H2011	9G0912H2021	9G0912H2011	9G0912H2D011	—	92 × 92 × 32 mm	No	150
9G0912M201	9G0912M202	9G0912M201	9G0912M2D01	—	92 × 92 × 32 mm	Yes	150
9G0912M2011	9G0912M2021	9G0912M2011	9G0912M2D011	—	92 × 92 × 32 mm	No	150
9G0912S201	9G0912S202	9G0912S201	9G0912S2D01	9G0912P2S01	92 × 92 × 32 mm	Yes	150
9G0912S2011	9G0912S2021	9G0912S2011	9G0912S2D011	—	92 × 92 × 32 mm	No	150
9G0924A201	9G0924A202	9G0924A201	9G0924A2D01	—	92 × 92 × 32 mm	Yes	150
9G0924A2011	9G0924A2021	9G0924A2011	9G0924A2D011	—	92 × 92 × 32 mm	No	150
9G0924G101	9G0924G102	9G0924G101	9G0924G1D01	—	92 × 92 × 38 mm	Yes	162
9G0924G1011	9G0924G1021	9G0924G1011	9G0924G1D011	—	92 × 92 × 38 mm	No	162
9G0924H101	9G0924H102	9G0924H101	9G0924H1D01	—	92 × 92 × 38 mm	Yes	162
9G0924H1011	9G0924H1021	9G0924H1011	9G0924H1D011	—	92 × 92 × 38 mm	No	162
9G0924H201	9G0924H202	9G0924H201	9G0924H2D01	—	92 × 92 × 32 mm	Yes	150
9G0924H2011	9G0924H2021	9G0924H2011	9G0924H2D011	—	92 × 92 × 32 mm	No	150
9G0924M201	9G0924M202	9G0924M201	9G0924M2D01	—	92 × 92 × 32 mm	Yes	150
9G0924M2011	9G0924M2021	9G0924M2011	9G0924M2D011	—	92 × 92 × 32 mm	No	150

Note 1: For compliance with standards, see individual product pages. Please contact your point of sale regarding low-speed sensors.

Note 2: The  mark indicates Short Lead Time Service applicable models. See p. 654 for details.

Models listed in product pages	List of models (Below are optional models and not listed in product pages. Standard compliance of these optional models may differ from that of the models listed in product pages. Contact us for details of "-" models.)				Frame size	Rib	page
	Without sensor	With pulse sensor	With lock sensor	With PWM control function and pulse sensor			
	9G0924S201	9G0924S202	9G0924S201	9G0924S2D01			
9G0924S2011	9G0924S2021	9G0924S2011	9G0924S2D011	—	92 × 92 × 32 mm	No	150
9G0948A201	9G0948A202	9G0948A201	9G0948A2D01	—	92 × 92 × 32 mm	Yes	150
9G0948A2011	9G0948A2021	9G0948A2011	9G0948A2D011	—	92 × 92 × 32 mm	No	150
9G0948G101	9G0948G102	9G0948G101	9G0948G1D01	—	92 × 92 × 38 mm	Yes	162
9G0948G1011	9G0948G1021	9G0948G1011	—	—	92 × 92 × 38 mm	No	162
9G0948H101	9G0948H102	9G0948H101	9G0948H1D01	—	92 × 92 × 38 mm	Yes	162
9G0948H1011	—	9G0948H1011	—	—	92 × 92 × 38 mm	No	162
9G0948H201	9G0948H202	9G0948H201	9G0948H2D01	—	92 × 92 × 32 mm	Yes	150
9G0948H2011	9G0948H2021	9G0948H2011	9G0948H2D011	—	92 × 92 × 32 mm	No	150
9G0948J101	—	9G0948J101	—	—	92 × 92 × 38 mm	Yes	162
9G0948J1011	—	9G0948J1011	—	9G0948P1J031	92 × 92 × 38 mm	No	162
9G0948M201	9G0948M202	9G0948M201	9G0948M2D01	—	92 × 92 × 32 mm	Yes	150
9G0948M2011	9G0948M2021	9G0948M2011	9G0948M2D011	—	92 × 92 × 32 mm	No	150
9G0948S201	9G0948S202	9G0948S201	9G0948S2D01	—	92 × 92 × 32 mm	Yes	150
9G0948S2011	9G0948S2021	9G0948S2011	9G0948S2D011	—	92 × 92 × 32 mm	No	150
9G1212A401	9G1212A402	9G1212A401	9G1212A4D01	—	120 × 120 × 25 mm	Yes	172
9G1212A4011	9G1212A4021	9G1212A4011	9G1212A4D011	—	120 × 120 × 25 mm	No	172
9G1212B401	—	9G1212B401	—	—	120 × 120 × 25 mm	Yes	172
9G1212B4011	—	9G1212B4011	—	—	120 × 120 × 25 mm	No	172
9G1212E101	9G1212E102	9G1212E101	9G1212E1D01	—	120 × 120 × 38 mm	Yes	186
9G1212E1011	9G1212E1021	9G1212E1011	9G1212E1D011	—	120 × 120 × 38 mm	No	186
9G1212E401	9G1212E402	9G1212E401	9G1212E4D01	9G1212P4E05	120 × 120 × 25 mm	Yes	172
9G1212E4011	9G1212E4021	9G1212E4011	9G1212E4D011	9G1212P4E041	120 × 120 × 25 mm	No	172
9G1212F101	9G1212F102	9G1212F101	9G1212F1D01	—	120 × 120 × 38 mm	Yes	186
9G1212F1011	9G1212F1021	9G1212F1011	—	—	120 × 120 × 38 mm	No	186
9G1212F401	9G1212F402	9G1212F401	9G1212F4D01	—	120 × 120 × 25 mm	Yes	172
9G1212F4011	9G1212F4021	9G1212F4011	9G1212F4D011	—	120 × 120 × 25 mm	No	172
9G1212G101	9G1212G102	9G1212G101	9G1212G1D01	9G1212P1G04	120 × 120 × 38 mm	Yes	186
9G1212G1011	9G1212G1021	9G1212G1011	9G1212G1D011	9G1212P1G081	120 × 120 × 38 mm	No	186
9G1212G401	9G1212G402	9G1212G401	9G1212G4D01	9G1212P4G03	120 × 120 × 25 mm	Yes	172
9G1212G4011	9G1212G4021	9G1212G4011	9G1212G4D011	9G1212P4G031	120 × 120 × 25 mm	No	172
9G1212H101	9G1212H102	9G1212H101	9G1212H1D01	—	120 × 120 × 38 mm	Yes	186
9G1212H1011	9G1212H1021	9G1212H1011	9G1212H1D011	—	120 × 120 × 38 mm	No	186
9G1212H401	9G1212H402	9G1212H401	9G1212H4D01	9G1212P4H04	120 × 120 × 25 mm	Yes	172
9G1212H4011	9G1212H4021	9G1212H4011	9G1212H4D011	9G1212P4H091	120 × 120 × 25 mm	No	172
9G1212M101	9G1212M102	9G1212M101	9G1212M1D01	—	120 × 120 × 38 mm	Yes	186
9G1212M1011	9G1212M1021	9G1212M1011	9G1212M1D011	—	120 × 120 × 38 mm	No	186
9G1212M401	9G1212M402	9G1212M401	9G1212M4D01	—	120 × 120 × 25 mm	Yes	172
9G1212M4011	9G1212M4021	9G1212M4011	9G1212M4D011	—	120 × 120 × 25 mm	No	172
9G1224A401	9G1224A402	9G1224A401	9G1224A4D01	—	120 × 120 × 25 mm	Yes	172
9G1224A4011	9G1224A4021	9G1224A4011	9G1224A4D011	—	120 × 120 × 25 mm	No	172
9G1224E101	9G1224E102	9G1224E101	9G1224E1D01	—	120 × 120 × 38 mm	Yes	186
9G1224E1011	9G1224E1021	9G1224E1011	9G1224E1D011	—	120 × 120 × 38 mm	No	186
9G1224E401	9G1224E402	9G1224E401	9G1224E4D01	9G1224P4E01	120 × 120 × 25 mm	Yes	172
9G1224E4011	9G1224E4021	9G1224E4011	9G1224E4D011	—	120 × 120 × 25 mm	No	172
9G1224F101	9G1224F102	9G1224F101	9G1224F1D01	—	120 × 120 × 38 mm	Yes	186
9G1224F1011	9G1224F1021	9G1224F1011	—	—	120 × 120 × 38 mm	No	186
9G1224F401	9G1224F402	9G1224F401	9G1224F4D01	—	120 × 120 × 25 mm	Yes	172
9G1224F4011	9G1224F4021	9G1224F4011	9G1224F4D011	—	120 × 120 × 25 mm	No	172
9G1224G101	9G1224G102	9G1224G101	9G1224G1D01	9G1224P1G01	120 × 120 × 38 mm	Yes	186
9G1224G1011	9G1224G1021	9G1224G1011	9G1224G1D011	—	120 × 120 × 38 mm	No	186
9G1224G401	9G1224G402	9G1224G401	9G1224G4D01	—	120 × 120 × 25 mm	Yes	172
9G1224G4011	9G1224G4021	9G1224G4011	9G1224G4D011	—	120 × 120 × 25 mm	No	172
9G1224H101	9G1224H102	9G1224H101	9G1224H1D01	—	120 × 120 × 38 mm	Yes	186
9G1224H1011	9G1224H1021	9G1224H1011	9G1224H1D011	—	120 × 120 × 38 mm	No	186
9G1224H401	9G1224H402	9G1224H401	9G1224H4D01	—	120 × 120 × 25 mm	Yes	172
9G1224H4011	9G1224H4021	9G1224H4011	9G1224H4D011	—	120 × 120 × 25 mm	No	172
9G1224M101	9G1224M102	9G1224M101	9G1224M1D01	—	120 × 120 × 38 mm	Yes	186
9G1224M1011	9G1224M1021	9G1224M1011	9G1224M1D011	—	120 × 120 × 38 mm	No	186
9G1224M401	9G1224M402	9G1224M401	9G1224M4D01	—	120 × 120 × 25 mm	Yes	172

Note 1: For compliance with standards, see individual product pages. Please contact your point of sale regarding low-speed sensors.

Note 2: The  mark indicates Short Lead Time Service applicable models. See p. 654 for details.

Models listed in product pages	List of models (Below are optional models and not listed in product pages. Standard compliance of these optional models may differ from that of the models listed in product pages. Contact us for details of "-" models.)				Frame size	Rib	page
	Without sensor	With pulse sensor	With lock sensor	With PWM control function and pulse sensor			
	9G1224M4011	9G1224M4021	9G1224M4011	9G1224M4D011			
9G1248A401	9G1248A402	9G1248A401	9G1248A4D01	—	120 × 120 × 25 mm	Yes	172
9G1248A4011	9G1248A4021	9G1248A4011	9G1248A4D011	—	120 × 120 × 25 mm	No	172
9G1248E101	9G1248E102	9G1248E101	9G1248E1D01	—	120 × 120 × 38 mm	Yes	186
9G1248E1011	9G1248E1021	9G1248E1011	9G1248E1D011	—	120 × 120 × 38 mm	No	186
9G1248E401	9G1248E402	9G1248E401	9G1248E4D01	9G1248P4E05	120 × 120 × 25 mm	Yes	172
9G1248E4011	9G1248E4021	9G1248E4011	9G1248E4D011	—	120 × 120 × 25 mm	No	172
9G1248F101	9G1248F102	9G1248F101	9G1248F1D01	—	120 × 120 × 38 mm	Yes	186
9G1248F1011	9G1248F1021	9G1248F1011	—	—	120 × 120 × 38 mm	No	186
9G1248F401	9G1248F402	9G1248F401	9G1248F4D01	—	120 × 120 × 25 mm	Yes	172
9G1248F4011	9G1248F4021	9G1248F4011	9G1248F4D011	—	120 × 120 × 25 mm	No	172
9G1248G101	9G1248G102	9G1248G101	9G1248G1D01	9G1248P1G04	120 × 120 × 38 mm	Yes	186
9G1248G1011	9G1248G1021	9G1248G1011	9G1248G1D011	9G1248P1G041	120 × 120 × 38 mm	No	186
9G1248G401	9G1248G402	9G1248G401	9G1248G4D01	9G1248P4G04	120 × 120 × 25 mm	Yes	172
9G1248G4011	9G1248G4021	9G1248G4011	9G1248G4D011	—	120 × 120 × 25 mm	No	172
9G1248H101	9G1248H102	9G1248H101	9G1248H1D01	—	120 × 120 × 38 mm	Yes	186
9G1248H1011	9G1248H1021	9G1248H1011	9G1248H1D011	—	120 × 120 × 38 mm	No	186
9G1248H401	9G1248H402	9G1248H401	9G1248H4D01	—	120 × 120 × 25 mm	Yes	172
9G1248H4011	9G1248H4021	9G1248H4011	9G1248H4D011	—	120 × 120 × 25 mm	No	172
9G1248M101	9G1248M102	9G1248M101	9G1248M1D01	—	120 × 120 × 38 mm	Yes	186
9G1248M1011	9G1248M1021	9G1248M1011	9G1248M1D011	—	120 × 120 × 38 mm	No	186
9G1248M401	9G1248M402	9G1248M401	9G1248M4D01	—	120 × 120 × 25 mm	Yes	172
9G1248M4011	9G1248M4021	9G1248M4011	9G1248M4D011	—	120 × 120 × 25 mm	No	172
9GA0312P3G001	—	9GA0312G3001	9GA0312G3D001	9GA0312P3G001	38 × 38 × 28 mm	Yes	18
9GA0312P3G0011	—	—	—	9GA0312P3G0011	38 × 38 × 28 mm	No	18
9GA0312P3J001	—	9GA0312J3001	—	9GA0312P3J001	38 × 38 × 28 mm	Yes	18
9GA0312P3J0011	—	—	—	9GA0312P3J0011	38 × 38 × 28 mm	No	18
9GA0312P3K001	—	9GA0312K3001	9GA0312K3D001	9GA0312P3K001	38 × 38 × 28 mm	Yes	18
9GA0312P3K0011	—	—	9GA0312K3D0011	9GA0312P3K0011	38 × 38 × 28 mm	No	18
9GA0405P6F001	9GA0405F6002	9GA0405F6001	—	9GA0405P6F001	40 × 40 × 20 mm	Yes	30
9GA0405P6H001	9GA0405H6002	9GA0405H6001	—	9GA0405P6H001	40 × 40 × 20 mm	Yes	30
9GA0412G7001	9GA0412G7002	9GA0412G7001	9GA0412G7D001	9GA0412P7G001	40 × 40 × 15 mm	Yes	25
9GA0412H7001	9GA0412H7002	9GA0412H7001	9GA0412H7D001	—	40 × 40 × 15 mm	Yes	25
9GA0412P3G01	9GA0412G302	9GA0412G301	—	9GA0412P3G01	40 × 40 × 28 mm	Yes	44
9GA0412P3G011	9GA0412G3021	9GA0412G3011	—	9GA0412P3G011	40 × 40 × 28 mm	No	44
9GA0412P3H01	9GA0412H302	9GA0412H301	9GA0412H3D01	9GA0412P3H01	40 × 40 × 28 mm	Yes	44
9GA0412P3H011	9GA0412H3021	9GA0412H3011	9GA0412H3D011	9GA0412P3H011	40 × 40 × 28 mm	No	44
9GA0412P3J01	9GA0412J302	9GA0412J301	9GA0412J3D01	9GA0412P3J01	40 × 40 × 28 mm	Yes	44
9GA0412P3J011	9GA0412J3021	9GA0412J3011	—	9GA0412P3J011	40 × 40 × 28 mm	No	44
9GA0412P3K01	9GA0412K302	9GA0412K301	9GA0412K3D01	9GA0412P3K01	40 × 40 × 28 mm	Yes	44
9GA0412P3K011	9GA0412K3021	9GA0412K3011	—	9GA0412P3K011	40 × 40 × 28 mm	No	44
9GA0412P3M01	9GA0412M302	9GA0412M301	9GA0412M3D01	9GA0412P3M01	40 × 40 × 28 mm	Yes	44
9GA0412P3M011	9GA0412M3021	9GA0412M3011	—	9GA0412P3M011	40 × 40 × 28 mm	No	44
9GA0412P6F001	9GA0412F6002	9GA0412F6001	—	9GA0412P6F001	40 × 40 × 20 mm	Yes	30
9GA0412P6G001	9GA0412G6002	9GA0412G6001	—	9GA0412P6G001	40 × 40 × 20 mm	Yes	30
9GA0412P6H001	9GA0412H6002	9GA0412H6001	—	9GA0412P6H001	40 × 40 × 20 mm	Yes	30
9GA0412P7G001	9GA0412G7002	9GA0412G7001	9GA0412G7D001	9GA0412P7G001	40 × 40 × 15 mm	Yes	25
9GA0424P3G001	9GA0424G3002	9GA0424G3001	9GA0424G3D001	9GA0424P3G001	40 × 40 × 28 mm	Yes	44
9GA0424P3G0011	9GA0424G30021	9GA0424G30011	—	9GA0424P3G0011	40 × 40 × 28 mm	No	44
9GA0424P3H001	9GA0424H3002	9GA0424H3001	9GA0424H3D001	9GA0424P3H001	40 × 40 × 28 mm	Yes	44
9GA0424P3H0011	9GA0424H30021	9GA0424H30011	—	9GA0424P3H0011	40 × 40 × 28 mm	No	44
9GA0424P3J001	9GA0424J3002	9GA0424J3001	9GA0424J3D001	9GA0424P3J001	40 × 40 × 28 mm	Yes	44
9GA0424P3J0011	9GA0424J30021	9GA0424J30011	—	9GA0424P3J0011	40 × 40 × 28 mm	No	44
9GA0424P3M001	9GA0424M3002	9GA0424M3001	—	9GA0424P3M001	40 × 40 × 28 mm	Yes	44
9GA0424P3M0011	9GA0424M30021	9GA0424M30011	9GA0424M3D001	9GA0424P3M0011	40 × 40 × 28 mm	No	44
9GA0424P6F001	9GA0424F6002	9GA0424F6001	9GA0424F6D001	9GA0424P6F001	40 × 40 × 20 mm	Yes	30
9GA0424P6G001	9GA0424G6002	9GA0424G6001	9GA0424G6D001	9GA0424P6G001	40 × 40 × 20 mm	Yes	30
9GA0424P6H001	9GA0424H6002	9GA0424H6001	9GA0424H6D001	9GA0424P6H001	40 × 40 × 20 mm	Yes	30
9GA0512P7A001	9GA0512A7002	9GA0512A7001	—	9GA0512P7A001	52 × 52 × 15 mm	Yes	56
9GA0512P7G001	9GA0512G7002	9GA0512G7001	—	9GA0512P7G001	52 × 52 × 15 mm	Yes	56
9GA0512P7H001	9GA0512H7002	9GA0512H7001	9GA0512H7D001	9GA0512P7H001	52 × 52 × 15 mm	Yes	56

Note 1: For compliance with standards, see individual product pages. Please contact your point of sale regarding low-speed sensors.

Note 2: The  mark indicates Short Lead Time Service applicable models. See p. 654 for details.

Models listed in product pages	List of models (Below are optional models and not listed in product pages. Standard compliance of these optional models may differ from that of the models listed in product pages. Contact us for details of "–" models.)				Frame size	Rib	page
	Without sensor	With pulse sensor	With lock sensor	With PWM control function and pulse sensor			
	9GA0512P7M001	9GA0512M7002	9GA0512M7001	–			
9GA0524P7A001	9GA0524A7002	9GA0524A7001	9GA0524A7D001	☞ 9GA0524P7A001	52 × 52 × 15 mm	Yes	56
9GA0524P7G001	9GA0524G7002	9GA0524G7001	9GA0524G7D001	☞ 9GA0524P7G001	52 × 52 × 15 mm	Yes	56
9GA0524P7H001	9GA0524H7002	9GA0524H7001	–	☞ 9GA0524P7H001	52 × 52 × 15 mm	Yes	56
9GA0524P7M001	9GA0524M7002	9GA0524M7001	–	☞ 9GA0524P7M001	52 × 52 × 15 mm	Yes	56
9GA0612G701	☞ 9GA0612G702	☞ 9GA0612G701	9GA0612G7D01	☞ 9GA0612P7G01	60 × 60 × 15 mm	Yes	64
9GA0612G9001	9GA0612G9002	☞ 9GA0612G9001	9GA0612G9D001	9GA0612P9G001	60 × 60 × 10 mm	Yes	62
9GA0612H6001	9GA0612H6002	☞ 9GA0612H6001	9GA0612H6D001	–	60 × 60 × 20 mm	Yes	67
9GA0612H701	☞ 9GA0612H702	☞ 9GA0612H701	9GA0612H7D01	☞ 9GA0612P7H01	60 × 60 × 15 mm	Yes	64
9GA0612H9001	9GA0612H9002	☞ 9GA0612H9001	9GA0612H9D001	–	60 × 60 × 10 mm	Yes	62
9GA0612L701	☞ 9GA0612L702	☞ 9GA0612L701	9GA0612L7D01	–	60 × 60 × 15 mm	Yes	64
9GA0612L9001	9GA0612L9002	☞ 9GA0612L9001	9GA0612L9D001	–	60 × 60 × 10 mm	Yes	62
9GA0612M6001	☞ 9GA0612M6002	☞ 9GA0612M6001	9GA0612M6D001	–	60 × 60 × 20 mm	Yes	67
9GA0612M701	☞ 9GA0612M702	☞ 9GA0612M701	–	–	60 × 60 × 15 mm	Yes	64
9GA0612P1H03	9GA0612H102	9GA0612H101	–	☞ 9GA0612P1H03	60 × 60 × 38 mm	Yes	85
9GA0612P1H031	9GA0612H1021	9GA0612H1011	–	9GA0612P1H031	60 × 60 × 38 mm	No	85
9GA0612P1J03	9GA0612J102	9GA0612J101	9GA0612J1D01	☞ 9GA0612P1J03	60 × 60 × 38 mm	Yes	85
9GA0612P1J031	9GA0612J1021	9GA0612J1011	–	9GA0612P1J031	60 × 60 × 38 mm	No	85
9GA0612P1K03	9GA0612K102	9GA0612K101	9GA0612K1D01	☞ 9GA0612P1K03	60 × 60 × 38 mm	Yes	85
9GA0612P1K031	9GA0612K1021	9GA0612K1011	9GA0612K1D011	☞ 9GA0612P1K031	60 × 60 × 38 mm	No	85
9GA0612P1K60	–	–	–	☞ 9GA0612P1K60	60 × 60 × 38 mm	Yes	85
9GA0612P1K601	–	–	–	☞ 9GA0612P1K601	60 × 60 × 38 mm	No	85
9GA0612P6G001	9GA0612G6002	9GA0612G6001	–	☞ 9GA0612P6G001	60 × 60 × 20 mm	Yes	67
9GA0612P6S001	9GA0612S6002	9GA0612S6001	–	☞ 9GA0612P6S001	60 × 60 × 20 mm	Yes	67
9GA0612P7G01	☞ 9GA0612G702	☞ 9GA0612G701	9GA0612G7D01	☞ 9GA0612P7G01	60 × 60 × 15 mm	Yes	64
9GA0612P7H01	☞ 9GA0612H702	☞ 9GA0612H701	9GA0612H7D01	☞ 9GA0612P7H01	60 × 60 × 15 mm	Yes	64
9GA0624H6001	☞ 9GA0624H6002	☞ 9GA0624H6001	☞ 9GA0624H6D001	–	60 × 60 × 20 mm	Yes	67
9GA0624M6001	☞ 9GA0624M6002	☞ 9GA0624M6001	9GA0624M6D001	–	60 × 60 × 20 mm	Yes	67
9GA0624M701	9GA0624M702	9GA0624M701	–	–	60 × 60 × 15 mm	Yes	64
9GA0624P1J03	9GA0624J102	9GA0624J101	–	☞ 9GA0624P1J03	60 × 60 × 38 mm	Yes	85
9GA0624P1J031	9GA0624J1021	9GA0624J1011	–	☞ 9GA0624P1J031	60 × 60 × 38 mm	No	85
9GA0624P1K03	9GA0624K102	–	9GA0624K1D01	9GA0624P1K03	60 × 60 × 38 mm	Yes	85
9GA0624P1K031	–	–	–	9GA0624P1K031	60 × 60 × 38 mm	No	85
9GA0624P6G001	9GA0624G6002	9GA0624G6001	9GA0624G6D001	☞ 9GA0624P6G001	60 × 60 × 20 mm	Yes	67
9GA0624P6S001	9GA0624S6002	9GA0624S6001	–	☞ 9GA0624P6S001	60 × 60 × 20 mm	Yes	67
9GA0624P7G01	9GA0624G702	–	–	☞ 9GA0624P7G01	60 × 60 × 15 mm	Yes	64
9GA0712P1G001	–	–	–	☞ 9GA0712P1G001	70 × 70 × 38 mm	Yes	91
9GA0712P1G0011	–	–	–	9GA0712P1G0011	70 × 70 × 38 mm	No	91
9GA0712P1H001	–	–	9GA0712H1D001	☞ 9GA0712P1H001	70 × 70 × 38 mm	Yes	91
9GA0712P1H0011	–	–	–	9GA0712P1H0011	70 × 70 × 38 mm	No	91
9GA0812A2001	☞ 9GA0812A2002	☞ 9GA0812A2001	☞ 9GA0812A2D001	–	80 × 80 × 32 mm	Yes	117
9GA0812A20011	☞ 9GA0812A20021	☞ 9GA0812A20011	☞ 9GA0812A2D0011	–	80 × 80 × 32 mm	No	117
9GA0812B2001	☞ 9GA0812B2002	☞ 9GA0812B2001	☞ 9GA0812B2D001	–	80 × 80 × 32 mm	Yes	117
9GA0812B20011	☞ 9GA0812B20021	☞ 9GA0812B20011	☞ 9GA0812B2D0011	–	80 × 80 × 32 mm	No	117
9GA0812H7001	9GA0812H7002	☞ 9GA0812H7001	9GA0812H7D001	–	80 × 80 × 15 mm	Yes	93
9GA0812L2001	☞ 9GA0812L2002	☞ 9GA0812L2001	☞ 9GA0812L2D001	–	80 × 80 × 32 mm	Yes	117
9GA0812L20011	☞ 9GA0812L20021	☞ 9GA0812L20011	☞ 9GA0812L2D0011	–	80 × 80 × 32 mm	No	117
9GA0812P1G61	–	–	–	☞ 9GA0812P1G61	80 × 80 × 38 mm	Yes	128
9GA0812P1G611	–	–	–	☞ 9GA0812P1G611	80 × 80 × 38 mm	No	128
9GA0812P1H61	9GA0812H162	9GA0812H161	9GA0812H1D61	☞ 9GA0812P1H61	80 × 80 × 38 mm	Yes	128
9GA0812P1H611	9GA0812H1621	9GA0812H1611	–	☞ 9GA0812P1H611	80 × 80 × 38 mm	No	128
9GA0812P1S61	9GA0812S162	9GA0812S161	9GA0812S1D61	☞ 9GA0812P1S61	80 × 80 × 38 mm	Yes	128
9GA0812P1S611	9GA0812S1621	9GA0812S1611	–	☞ 9GA0812P1S611	80 × 80 × 38 mm	No	128
9GA0812P2H001	–	–	–	☞ 9GA0812P2H001	80 × 80 × 32 mm	Yes	117
9GA0812P2H0011	–	–	–	☞ 9GA0812P2H0011	80 × 80 × 32 mm	No	117
9GA0812P2M001	–	–	–	☞ 9GA0812P2M001	80 × 80 × 32 mm	Yes	117
9GA0812P2M0011	–	–	–	☞ 9GA0812P2M0011	80 × 80 × 32 mm	No	117
9GA0812P2S001	–	☞ 9GA0812S2001	–	☞ 9GA0812P2S001	80 × 80 × 32 mm	Yes	117
9GA0812P2S0011	–	–	–	☞ 9GA0812P2S0011	80 × 80 × 32 mm	No	117
9GA0812P4G001	9GA0812G4002	9GA0812G4001	9GA0812G4D001	☞ 9GA0812P4G001	80 × 80 × 25 mm	Yes	104
9GA0812P4G0011	9GA0812G40021	9GA0812G40011	–	☞ 9GA0812P4G0011	80 × 80 × 25 mm	No	104

Note 1: For compliance with standards, see individual product pages. Please contact your point of sale regarding low-speed sensors.

Note 2: The ☞ mark indicates Short Lead Time Service applicable models. See p. 654 for details.

Models listed in product pages	List of models (Below are optional models and not listed in product pages. Standard compliance of these optional models may differ from that of the models listed in product pages. Contact us for details of "—" models.)				Frame size	Rib	page
	Without sensor	With pulse sensor	With lock sensor	With PWM control function and pulse sensor			
	9GA0812P4H001	9GA0812H4002	9GA0812H4001	9GA0812H4D001			
9GA0812P4H0011	9GA0812H40021	9GA0812H40011	—	☛ 9GA0812P4H0011	80 × 80 × 25 mm	No	104
9GA0812P4J001	9GA0812J4002	9GA0812J4001	9GA0812J4D001	☛ 9GA0812P4J001	80 × 80 × 25 mm	Yes	104
9GA0812P4J0011	9GA0812J40021	9GA0812J40011	—	☛ 9GA0812P4J0011	80 × 80 × 25 mm	No	104
9GA0812P6G001	9GA0812G6002	9GA0812G6001	—	☛ 9GA0812P6G001	80 × 80 × 20 mm	Yes	98
9GA0812P6M001	9GA0812M6002	9GA0812M6001	—	☛ 9GA0812P6M001	80 × 80 × 20 mm	Yes	98
9GA0812P7G001	9GA0812G7002	9GA0812G7001	9GA0812G7D001	☛ 9GA0812P7G001	80 × 80 × 15 mm	Yes	93
9GA0812P7S001	—	—	—	☛ 9GA0812P7S001	80 × 80 × 15 mm	Yes	93
9GA0824A2001	☛ 9GA0824A2002	☛ 9GA0824A2001	☛ 9GA0824A2D001	—	80 × 80 × 32 mm	Yes	117
9GA0824A20011	☛ 9GA0824A20021	☛ 9GA0824A20011	9GA0824A2D0011	—	80 × 80 × 32 mm	No	117
9GA0824B2001	☛ 9GA0824B2002	☛ 9GA0824B2001	☛ 9GA0824B2D001	—	80 × 80 × 32 mm	Yes	117
9GA0824B20011	☛ 9GA0824B20021	☛ 9GA0824B20011	☛ 9GA0824B2D0011	—	80 × 80 × 32 mm	No	117
9GA0824H7001	9GA0824H7002	☛ 9GA0824H7001	9GA0824H7D001	—	80 × 80 × 15 mm	Yes	93
9GA0824L2001	☛ 9GA0824L2002	☛ 9GA0824L2001	☛ 9GA0824L2D001	—	80 × 80 × 32 mm	Yes	117
9GA0824L20011	☛ 9GA0824L20021	☛ 9GA0824L20011	☛ 9GA0824L2D0011	—	80 × 80 × 32 mm	No	117
9GA0824P1H61	9GA0824H162	9GA0824H161	9GA0824H1D61	☛ 9GA0824P1H61	80 × 80 × 38 mm	Yes	128
9GA0824P1H611	9GA0824H1621	9GA0824H1611	—	☛ 9GA0824P1H611	80 × 80 × 38 mm	No	128
9GA0824P1S61	9GA0824S162	9GA0824S161	—	☛ 9GA0824P1S61	80 × 80 × 38 mm	Yes	128
9GA0824P1S611	9GA0824S1621	9GA0824S1611	—	☛ 9GA0824P1S611	80 × 80 × 38 mm	No	128
9GA0824P2S001	9GA0824S2002	—	—	☛ 9GA0824P2S001	80 × 80 × 32 mm	Yes	117
9GA0824P2S0011	—	—	—	☛ 9GA0824P2S0011	80 × 80 × 32 mm	No	117
9GA0824P4G001	9GA0824G4002	9GA0824G4001	9GA0824G4D001	☛ 9GA0824P4G001	80 × 80 × 25 mm	Yes	104
9GA0824P4G0011	9GA0824G40021	9GA0824G40011	—	9GA0824P4G0011	80 × 80 × 25 mm	No	104
9GA0824P4H001	9GA0824H4002	9GA0824H4001	9GA0824H4D001	☛ 9GA0824P4H001	80 × 80 × 25 mm	Yes	104
9GA0824P4H0011	9GA0824H40021	9GA0824H40011	—	9GA0824P4H0011	80 × 80 × 25 mm	No	104
9GA0824P4J001	9GA0824J4002	9GA0824J4001	9GA0824J4D001	☛ 9GA0824P4J001	80 × 80 × 25 mm	Yes	104
9GA0824P4J0011	9GA0824J40021	9GA0824J40011	9GA0824J4D0011	☛ 9GA0824P4J0011	80 × 80 × 25 mm	No	104
9GA0824P6G001	9GA0824G6002	9GA0824G6001	—	☛ 9GA0824P6G001	80 × 80 × 20 mm	Yes	98
9GA0824P6M001	9GA0824M6002	9GA0824M6001	—	☛ 9GA0824P6M001	80 × 80 × 20 mm	Yes	98
9GA0824P7G001	9GA0824G7002	—	9GA0824G7D001	☛ 9GA0824P7G001	80 × 80 × 15 mm	Yes	93
9GA0824P7S001	9GA0824S7002	—	—	☛ 9GA0824P7S001	80 × 80 × 15 mm	Yes	93
9GA0848P1S61	—	—	—	9GA0848P1S61	80 × 80 × 38 mm	Yes	128
9GA0848P1S611	—	—	—	9GA0848P1S611	80 × 80 × 38 mm	No	128
9GA0848P2S001	—	—	—	9GA0848P2S001	80 × 80 × 32 mm	Yes	117
9GA0848P2S0011	—	—	—	9GA0848P2S0011	80 × 80 × 32 mm	No	117
9GA0912F401	☛ 9GA0912F402	☛ 9GA0912F401	☛ 9GA0912F4D01	—	92 × 92 × 25 mm	Yes	140
9GA0912F4011	☛ 9GA0912F4021	☛ 9GA0912F4011	☛ 9GA0912F4D011	—	92 × 92 × 25 mm	No	140
9GA0912H401	☛ 9GA0912H402	☛ 9GA0912H401	☛ 9GA0912H4D01	—	92 × 92 × 25 mm	Yes	140
9GA0912H4011	☛ 9GA0912H4021	☛ 9GA0912H4011	☛ 9GA0912H4D011	—	92 × 92 × 25 mm	No	140
9GA0912L401	☛ 9GA0912L402	☛ 9GA0912L401	☛ 9GA0912L4D01	—	92 × 92 × 25 mm	Yes	140
9GA0912L4011	☛ 9GA0912L4021	☛ 9GA0912L4011	☛ 9GA0912L4D011	—	92 × 92 × 25 mm	No	140
9GA0912M401	☛ 9GA0912M402	☛ 9GA0912M401	☛ 9GA0912M4D01	—	92 × 92 × 25 mm	Yes	140
9GA0912M4011	☛ 9GA0912M4021	☛ 9GA0912M4011	☛ 9GA0912M4D011	—	92 × 92 × 25 mm	No	140
9GA0912P1H03	9GA0912H102	9GA0912H101	9GA0912H1D01	☛ 9GA0912P1H03	92 × 92 × 38 mm	Yes	156
9GA0912P1H031	9GA0912H1021	9GA0912H1011	—	☛ 9GA0912P1H031	92 × 92 × 38 mm	No	156
9GA0912P4G03	9GA0912G402	9GA0912G401	9GA0912G4D01	☛ 9GA0912P4G03	92 × 92 × 25 mm	Yes	140
9GA0912P4G031	9GA0912G4021	9GA0912G4011	—	☛ 9GA0912P4G031	92 × 92 × 25 mm	No	140
9GA0912P4J03	☛ 9GA0912J402	☛ 9GA0912J401	☛ 9GA0912J4D01	☛ 9GA0912P4J03	92 × 92 × 25 mm	Yes	140
9GA0912P4J031	☛ 9GA0912J4021	☛ 9GA0912J4011	☛ 9GA0912J4D011	☛ 9GA0912P4J031	92 × 92 × 25 mm	No	140
9GA0912P4S03	☛ 9GA0912S402	☛ 9GA0912S401	☛ 9GA0912S4D01	☛ 9GA0912P4S03	92 × 92 × 25 mm	Yes	140
9GA0912P4S031	☛ 9GA0912S4021	☛ 9GA0912S4011	☛ 9GA0912S4D011	☛ 9GA0912P4S031	92 × 92 × 25 mm	No	140
9GA0912W401	☛ 9GA0912W402	☛ 9GA0912W401	☛ 9GA0912W4D01	—	92 × 92 × 25 mm	Yes	140
9GA0912W4011	☛ 9GA0912W4021	☛ 9GA0912W4011	☛ 9GA0912W4D011	—	92 × 92 × 25 mm	No	140
9GA0924F401	☛ 9GA0924F402	☛ 9GA0924F401	☛ 9GA0924F4D01	—	92 × 92 × 25 mm	Yes	140
9GA0924F4011	☛ 9GA0924F4021	☛ 9GA0924F4011	☛ 9GA0924F4D011	—	92 × 92 × 25 mm	No	140
9GA0924H401	☛ 9GA0924H402	☛ 9GA0924H401	☛ 9GA0924H4D01	—	92 × 92 × 25 mm	Yes	140
9GA0924H4011	☛ 9GA0924H4021	☛ 9GA0924H4011	☛ 9GA0924H4D011	—	92 × 92 × 25 mm	No	140
9GA0924L401	☛ 9GA0924L402	☛ 9GA0924L401	☛ 9GA0924L4D01	—	92 × 92 × 25 mm	Yes	140
9GA0924L4011	☛ 9GA0924L4021	☛ 9GA0924L4011	☛ 9GA0924L4D011	—	92 × 92 × 25 mm	No	140
9GA0924M401	☛ 9GA0924M402	☛ 9GA0924M401	☛ 9GA0924M4D01	—	92 × 92 × 25 mm	Yes	140
9GA0924M4011	☛ 9GA0924M4021	☛ 9GA0924M4011	☛ 9GA0924M4D011	—	92 × 92 × 25 mm	No	140

Note 1: For compliance with standards, see individual product pages. Please contact your point of sale regarding low-speed sensors.

Note 2: The ☛ mark indicates Short Lead Time Service applicable models. See p. 654 for details.

Models listed in product pages	List of models (Below are optional models and not listed in product pages. Standard compliance of these optional models may differ from that of the models listed in product pages. Contact us for details of "—" models.)				Frame size	Rib	page
	Without sensor	With pulse sensor	With lock sensor	With PWM control function and pulse sensor			
	9GA0924P1H01	9GA0924H102	9GA0924H101	9GA0924H1D01			
9GA0924P1H011	—	9GA0924H1011	9GA0924H1D011	9GA0924P1H011	92 × 92 × 38 mm	No	156
9GA0924P4G03	9GA0924G402	9GA0924G401	9GA0924G4D01	9GA0924P4G03	92 × 92 × 25 mm	Yes	140
9GA0924P4G031	9GA0924G4021	9GA0924G4011	—	9GA0924P4G031	92 × 92 × 25 mm	No	140
9GA0924P4J03	9GA0924J402	9GA0924J401	9GA0924J4D01	9GA0924P4J03	92 × 92 × 25 mm	Yes	140
9GA0924P4J031	9GA0924J4021	9GA0924J4011	—	9GA0924P4J031	92 × 92 × 25 mm	No	140
9GA0924P4S03	9GA0924S402	9GA0924S401	9GA0924S4D01	9GA0924P4S03	92 × 92 × 25 mm	Yes	140
9GA0924P4S031	9GA0924S4021	9GA0924S4011	—	9GA0924P4S031	92 × 92 × 25 mm	No	140
9GA0924W401	9GA0924W402	9GA0924W401	9GA0924W4D01	—	92 × 92 × 25 mm	Yes	140
9GA0924W4011	9GA0924W4021	9GA0924W4011	9GA0924W4D011	—	92 × 92 × 25 mm	No	140
9GA0948P1H03	9GA0948H102	9GA0948H101	—	9GA0948P1H03	92 × 92 × 38 mm	Yes	156
9GA0948P1H031	—	—	—	9GA0948P1H031	92 × 92 × 38 mm	No	156
9GA1212G4001	—	9GA1212G4001	—	9GA1212P4G001	120 × 120 × 25 mm	Yes	165
9GA1212G40011	—	9GA1212G40011	—	9GA1212P4G0011	120 × 120 × 25 mm	No	165
9GA1212P4G001	—	9GA1212G4001	—	9GA1212P4G001	120 × 120 × 25 mm	Yes	165
9GA1212P4G0011	—	9GA1212G40011	—	9GA1212P4G0011	120 × 120 × 25 mm	No	165
9GA1212P4S001	—	9GA1212S4001	—	9GA1212P4S001	120 × 120 × 25 mm	Yes	165
9GA1212P4S0011	—	9GA1212S40011	—	9GA1212P4S0011	120 × 120 × 25 mm	No	165
9GA1212S4001	—	9GA1212S4001	—	9GA1212P4S001	120 × 120 × 25 mm	Yes	165
9GA1212S40011	—	9GA1212S40011	—	9GA1212P4S0011	120 × 120 × 25 mm	No	165
9GA1224G4001	9GA1224G4002	9GA1224G4001	9GA1224G4D001	9GA1224P4G001	120 × 120 × 25 mm	Yes	165
9GA1224G40011	—	9GA1224G40011	—	9GA1224P4G0011	120 × 120 × 25 mm	No	165
9GA1224P4G001	9GA1224G4002	9GA1224G4001	9GA1224G4D001	9GA1224P4G001	120 × 120 × 25 mm	Yes	165
9GA1224P4G0011	—	9GA1224G40011	—	9GA1224P4G0011	120 × 120 × 25 mm	No	165
9GA1224P4S001	—	9GA1224S4001	9GA1224S4D001	9GA1224P4S001	120 × 120 × 25 mm	Yes	165
9GA1224P4S0011	—	9GA1224S40011	—	9GA1224P4S0011	120 × 120 × 25 mm	No	165
9GA1224S4001	9GA1224S4002	9GA1224S4001	—	9GA1224P4S001	120 × 120 × 25 mm	Yes	165
9GA1224S40011	—	9GA1224S40011	—	9GA1224P4S0011	120 × 120 × 25 mm	No	165
9GA1248G4001	—	9GA1248G4001	—	9GA1248P4G001	120 × 120 × 25 mm	Yes	165
9GA1248G40011	—	9GA1248G40011	—	9GA1248P4G0011	120 × 120 × 25 mm	No	165
9GA1248P4G001	—	9GA1248G4001	—	9GA1248P4G001	120 × 120 × 25 mm	Yes	165
9GA1248P4G0011	—	9GA1248G40011	—	9GA1248P4G0011	120 × 120 × 25 mm	No	165
9GA1248P4S001	—	9GA1248S4001	—	9GA1248P4S001	120 × 120 × 25 mm	Yes	165
9GA1248P4S0011	—	9GA1248S40011	—	9GA1248P4S0011	120 × 120 × 25 mm	No	165
9GA1248S4001	—	9GA1248S4001	—	9GA1248P4S001	120 × 120 × 25 mm	Yes	165
9GA1248S40011	—	9GA1248S40011	—	9GA1248P4S0011	120 × 120 × 25 mm	No	165
9GAX0412P3K001	—	—	—	9GAX0412P3K001	40 × 40 × 28 mm	Yes	39
9GAX0412P3K0011	—	—	—	9GAX0412P3K0011	40 × 40 × 28 mm	No	39
9GAX0412P3K003	—	—	—	9GAX0412P3K003	40 × 40 × 28 mm	Yes	39
9GAX0412P3K0031	—	—	—	9GAX0412P3K0031	40 × 40 × 28 mm	No	39
9GAX0412P3S001	—	—	—	9GAX0412P3S001	40 × 40 × 28 mm	Yes	39
9GAX0412P3S0011	—	—	—	9GAX0412P3S0011	40 × 40 × 28 mm	No	39
9GAX0412P3S003	—	—	—	9GAX0412P3S003	40 × 40 × 28 mm	Yes	39
9GAX0412P3S0031	—	—	—	9GAX0412P3S0031	40 × 40 × 28 mm	No	39
9GE0412P3G03	—	—	9GE0412G3D01	9GE0412P3G03	40 × 40 × 28 mm	No	48
9GE0412P3J03	9GE0412J302	9GE0412J301	9GE0412J3D01	9GE0412P3J03	40 × 40 × 28 mm	No	48
9GE0412P3K03	—	9GE0412K301	9GE0412K3D01	9GE0412P3K03	40 × 40 × 28 mm	No	48
9GL1212E101	9GL1212E102	9GL1212E101	9GL1212E1D01	—	120 × 120 × 38 mm	No	425
9GL1212F101	9GL1212F102	9GL1212F101	9GL1212F1D01	—	120 × 120 × 38 mm	No	425
9GL1212G101	9GL1212G102	9GL1212G101	9GL1212G1D01	—	120 × 120 × 38 mm	No	425
9GL1212H101	9GL1212H102	9GL1212H101	9GL1212H1D01	—	120 × 120 × 38 mm	No	425
9GL1212M101	9GL1212M102	9GL1212M101	9GL1212M1D01	—	120 × 120 × 38 mm	No	425
9GL1224E101	9GL1224E102	9GL1224E101	9GL1224E1D01	—	120 × 120 × 38 mm	No	425
9GL1224F101	9GL1224F102	9GL1224F101	9GL1224F1D01	—	120 × 120 × 38 mm	No	425
9GL1224G101	9GL1224G102	9GL1224G101	9GL1224G1D01	—	120 × 120 × 38 mm	No	425
9GL1224H101	9GL1224H102	9GL1224H101	9GL1224H1D01	—	120 × 120 × 38 mm	No	425
9GL1224M101	9GL1224M102	9GL1224M101	9GL1224M1D01	—	120 × 120 × 38 mm	No	425
9GL1248E101	9GL1248E102	9GL1248E101	9GL1248E1D01	—	120 × 120 × 38 mm	No	425
9GL1248F101	9GL1248F102	9GL1248F101	9GL1248F1D01	—	120 × 120 × 38 mm	No	425
9GL1248G101	9GL1248G102	9GL1248G101	9GL1248G1D01	—	120 × 120 × 38 mm	No	425
9GL1248H101	9GL1248H102	9GL1248H101	9GL1248H1D01	—	120 × 120 × 38 mm	No	425

Note 1: For compliance with standards, see individual product pages. Please contact your point of sale regarding low-speed sensors.

Note 2: The  mark indicates Short Lead Time Service applicable models. See p. 654 for details.

Models listed in product pages	List of models (Below are optional models and not listed in product pages. Standard compliance of these optional models may differ from that of the models listed in product pages. Contact us for details of "-" models.)				Frame size	Rib	page
	Without sensor	With pulse sensor	With lock sensor	With PWM control function and pulse sensor			
	9GL1248M101	9GL1248M102	9GL1248M101	9GL1248M1D01			
9GP1224P1G001	9GP1224G1002	—	—	9GP1224P1G001	120 × 120 × 38 mm	No	458
9GP1248P1G001	—	—	—	9GP1248P1G001	120 × 120 × 38 mm	No	458
9GP5724P5H001	—	—	—	9GP5724P5H001	∅172 × 150 × 51 mm	No	460
9GP5748P5G001	—	—	—	9GP5748P5G001	∅172 × 150 × 51 mm	No	460
9GT0412P3J001	9GT0412J3002	9GT0412J3001	9GT0412J3D001	☺ 9GT0412P3J001	40 × 40 × 28 mm	No	444
9GT0424P3J001	9GT0424J3002	9GT0424J3001	9GT0424J3D001	☺ 9GT0424P3J001	40 × 40 × 28 mm	No	444
9GT0612P4G001	9GT0612G4002	9GT0612G4001	9GT0612G4D001	☺ 9GT0612P4G001	60 × 60 × 25 mm	No	446
9GT0624P4G001	9GT0624G4002	9GT0624G4001	—	☺ 9GT0624P4G001	60 × 60 × 25 mm	No	446
9GT0812P4S001	9GT0812S4002	9GT0812S4001	9GT0812S4D001	☺ 9GT0812P4S001	80 × 80 × 25 mm	No	448
9GT0824P4S001	9GT0824S4002	9GT0824S4001	—	☺ 9GT0824P4S001	80 × 80 × 25 mm	No	448
9GT0912P1M001	9GT0912M1002	9GT0912M1001	9GT0912M1D001	☺ 9GT0912P1M001	92 × 92 × 38 mm	No	452
9GT0912P4J001	9GT0912J4002	9GT0912J4001	9GT0912J4D001	☺ 9GT0912P4J001	92 × 92 × 25 mm	No	450
9GT0924P1M001	9GT0924M1002	—	9GT0924M1D001	☺ 9GT0924P1M001	92 × 92 × 38 mm	No	452
9GT0924P4J001	9GT0924J4002	9GT0924J4001	—	☺ 9GT0924P4J001	92 × 92 × 25 mm	No	450
9GT1212P1S001	—	—	—	☺ 9GT1212P1S001	120 × 120 × 38 mm	No	454
9GT1224P1S001	9GT1224S1002	—	9GT1224S1D001	☺ 9GT1224P1S001	120 × 120 × 38 mm	No	454
9GV0312E301	9GV0312E302	9GV0312E301	9GV0312E3D01	—	38 × 38 × 28 mm	Yes	21
9GV0312E3011	—	9GV0312E3011	9GV0312E3D011	—	38 × 38 × 28 mm	No	21
9GV0312G301	9GV0312G302	9GV0312G301	9GV0312G3D01	9GV0312P3G03	38 × 38 × 28 mm	Yes	21
9GV0312G3011	9GV0312G3021	9GV0312G3011	—	—	38 × 38 × 28 mm	No	21
9GV0312H301	9GV0312H302	9GV0312H301	9GV0312H3D01	—	38 × 38 × 28 mm	Yes	21
9GV0312H3011	—	9GV0312H3011	—	—	38 × 38 × 28 mm	No	21
9GV0312J301	9GV0312J302	9GV0312J301	9GV0312J3D01	9GV0312P3J03	38 × 38 × 28 mm	Yes	21
9GV0312J3011	9GV0312J3021	9GV0312J3011	—	9GV0312P3J031	38 × 38 × 28 mm	No	21
9GV0312K301	—	9GV0312K301	9GV0312K3D01	9GV0312P3K01	38 × 38 × 28 mm	Yes	21
9GV0312K3011	—	9GV0312K3011	9GV0312K3D011	—	38 × 38 × 28 mm	No	21
9GV0412C301	—	9GV0412C301	9GV0412C3D01	—	40 × 40 × 28 mm	Yes	51
9GV0412C3011	—	9GV0412C3011	9GV0412C3D011	—	40 × 40 × 28 mm	No	51
9GV0412G301	9GV0412G302	9GV0412G301	9GV0412G3D01	9GV0412P3G03	40 × 40 × 28 mm	Yes	51
9GV0412G3011	9GV0412G3021	9GV0412G3011	9GV0412G3D011	9GV0412P3G031	40 × 40 × 28 mm	No	51
9GV0412H301	—	9GV0412H301	9GV0412H3D01	9GV0412P3H01	40 × 40 × 28 mm	Yes	51
9GV0412H3011	—	9GV0412H3011	—	—	40 × 40 × 28 mm	No	51
9GV0412J301	9GV0412J302	9GV0412J301	9GV0412J3D01	9GV0412P3J03	40 × 40 × 28 mm	Yes	51
9GV0412J3011	9GV0412J3021	9GV0412J3011	9GV0412J3D011	9GV0412P3J031	40 × 40 × 28 mm	No	51
9GV0412K301	9GV0412K302	9GV0412K301	9GV0412K3D01	9GV0412P3K03	40 × 40 × 28 mm	Yes	51
9GV0412K3011	—	9GV0412K3011	—	—	40 × 40 × 28 mm	No	51
9GV0612P1G03	9GV0612G102	9GV0612G101	9GV0612G1D01	9GV0612P1G03	60 × 60 × 38 mm	Yes	88
9GV0612P1G031	9GV0612G1021	9GV0612G1011	9GV0612G1D011	9GV0612P1G031	60 × 60 × 38 mm	No	88
9GV0624P1G03	9GV0624G102	—	9GV0624G1D01	9GV0624P1G03	60 × 60 × 38 mm	Yes	88
9GV0624P1G031	9GV0624G1021	—	—	9GV0624P1G031	60 × 60 × 38 mm	No	88
9GV0648P1H03	—	—	—	9GV0648P1H03	60 × 60 × 38 mm	Yes	88
9GV0648P1H031	—	—	—	9GV0648P1H031	60 × 60 × 38 mm	No	88
9GV0812P1F03	—	—	—	9GV0812P1F03	80 × 80 × 38 mm	Yes	131
9GV0812P1F031	—	—	—	9GV0812P1F031	80 × 80 × 38 mm	No	131
9GV0812P1G03	9GV0812G102	9GV0812G101	—	9GV0812P1G03	80 × 80 × 38 mm	Yes	131
9GV0812P1G031	9GV0812G1021	9GV0812G1011	—	9GV0812P1G031	80 × 80 × 38 mm	No	131
9GV0812P1H03	9GV0812H102	9GV0812H101	—	9GV0812P1H03	80 × 80 × 38 mm	Yes	131
9GV0812P1H031	9GV0812H1021	9GV0812H1011	—	9GV0812P1H031	80 × 80 × 38 mm	No	131
9GV0812P1M03	—	—	—	9GV0812P1M03	80 × 80 × 38 mm	Yes	131
9GV0812P1M031	—	—	—	9GV0812P1M031	80 × 80 × 38 mm	No	131
9GV0824P1G03	9GV0824G102	9GV0824G101	9GV0824G1D01	9GV0824P1G03	80 × 80 × 38 mm	Yes	131
9GV0824P1G031	—	—	—	9GV0824P1G031	80 × 80 × 38 mm	No	131
9GV0848P1G03	9GV0848G102	9GV0848G101	—	9GV0848P1G03	80 × 80 × 38 mm	Yes	131
9GV0848P1G031	—	9GV0848G1011	—	9GV0848P1G031	80 × 80 × 38 mm	No	131
9GV0848P4K03	—	9GV0848K401	—	☺ 9GV0848P4K03	80 × 80 × 25 mm	Yes	107
9GV0848P4K031	—	—	—	☺ 9GV0848P4K031	80 × 80 × 25 mm	No	107
9GV0912P1F03	—	—	—	9GV0912P1F03	92 × 92 × 38 mm	Yes	159
9GV0912P1F031	—	—	—	9GV0912P1F031	92 × 92 × 38 mm	No	159
9GV0912P1G03	9GV0912G102	—	9GV0912G1D01	9GV0912P1G03	92 × 92 × 38 mm	Yes	159
9GV0912P1G031	—	—	—	9GV0912P1G031	92 × 92 × 38 mm	No	159

Note 1: For compliance with standards, see individual product pages. Please contact your point of sale regarding low-speed sensors.

Note 2: The ☺ mark indicates Short Lead Time Service applicable models. See p. 654 for details.

Models listed in product pages	List of models (Below are optional models and not listed in product pages. Standard compliance of these optional models may differ from that of the models listed in product pages. Contact us for details of "—" models.)				Frame size	Rib	page
	Without sensor	With pulse sensor	With lock sensor	With PWM control function and pulse sensor			
	9GV0912P1H03	9GV0912H102	9GV0912H101	9GV0912H1D01			
9GV0912P1H031	—	—	—	9GV0912P1H031	92 × 92 × 38 mm	No	159
9GV0948P1F03	—	—	—	9GV0948P1F03	92 × 92 × 38 mm	Yes	159
9GV0948P1F031	—	—	—	9GV0948P1F031	92 × 92 × 38 mm	No	159
9GV0948P1H03	9GV0948H102	9GV0948H101	—	9GV0948P1H03	92 × 92 × 38 mm	Yes	159
9GV0948P1H031	9GV0948H1021	—	—	9GV0948P1H031	92 × 92 × 38 mm	No	159
9GV1212P1G01	—	—	—	9GV1212P1G01	120 × 120 × 38 mm	Yes	181
9GV1212P1G011	—	9GV1212G1011	9GV1212G1D011	9GV1212P1G011	120 × 120 × 38 mm	No	181
9GV1212P1J01	9GV1212J102	9GV1212J101	9GV1212J1D01	9GV1212P1J01	120 × 120 × 38 mm	Yes	181
9GV1212P1J011	9GV1212J1021	9GV1212J1011	—	9GV1212P1J011	120 × 120 × 38 mm	No	181
9GV1212P4G01	9GV1212G402	9GV1212G401	—	9GV1212P4G01	120 × 120 × 25 mm	Yes	169
9GV1212P4G011	9GV1212G4021	9GV1212G4011	—	9GV1212P4G011	120 × 120 × 25 mm	No	169
9GV1224P1H01	9GV1224H102	9GV1224H101	9GV1224H1D01	9GV1224P1H01	120 × 120 × 38 mm	Yes	181
9GV1224P1H011	9GV1224H1021	9GV1224H1011	9GV1224H1D011	9GV1224P1H011	120 × 120 × 38 mm	No	181
9GV1224P1J01	9GV1224J102	9GV1224J101	9GV1224J1D01	9GV1224P1J01	120 × 120 × 38 mm	Yes	181
9GV1224P1J011	9GV1224J1021	9GV1224J1011	9GV1224J1D011	9GV1224P1J011	120 × 120 × 38 mm	No	181
9GV1224P4G01	9GV1224G402	9GV1224G401	9GV1224G4D01	9GV1224P4G01	120 × 120 × 25 mm	Yes	169
9GV1224P4G011	9GV1224G4021	—	—	9GV1224P4G011	120 × 120 × 25 mm	No	169
9GV1248P1J01	9GV1248J102	9GV1248J101	9GV1248J1D01	9GV1248P1J01	120 × 120 × 38 mm	Yes	181
9GV1248P1J011	9GV1248J1021	9GV1248J1011	—	9GV1248P1J011	120 × 120 × 38 mm	No	181
9GV1248P4G01	9GV1248G402	9GV1248G401	—	9GV1248P4G01	120 × 120 × 25 mm	Yes	169
9GV1248P4G011	—	9GV1248G4011	—	9GV1248P4G011	120 × 120 × 25 mm	No	169
9GV1248P4H01	9GV1248H402	9GV1248H401	9GV1248H4D01	9GV1248P4H01	120 × 120 × 25 mm	Yes	169
9GV1248P4H011	—	—	—	9GV1248P4H011	120 × 120 × 25 mm	No	169
9GV1248P4J01	—	—	—	9GV1248P4J01	120 × 120 × 25 mm	Yes	169
9GV1248P4J011	—	—	—	9GV1248P4J011	120 × 120 × 25 mm	No	169
9GV1412P1G001	—	—	—	9GV1412P1G001	140 × 140 × 38 mm	No	194
9GV1412P1H001	9GV1412H1002	—	—	9GV1412P1H001	140 × 140 × 38 mm	No	194
9GV1412P1S001	—	—	—	9GV1412P1S001	140 × 140 × 38 mm	No	194
9GV1424P1G001	—	—	—	9GV1424P1G001	140 × 140 × 38 mm	No	194
9GV1424P1H001	9GV1424H1002	—	9GV1424H1D001	9GV1424P1H001	140 × 140 × 38 mm	No	194
9GV1424P1S001	—	—	—	9GV1424P1S001	140 × 140 × 38 mm	No	194
9GV1448P1G001	—	—	—	9GV1448P1G001	140 × 140 × 38 mm	No	194
9GV1448P1H001	—	—	—	9GV1448P1H001	140 × 140 × 38 mm	No	194
9GV1448P1S001	—	—	—	9GV1448P1S001	140 × 140 × 38 mm	No	194
9GV1512H501	9GV1512H502	9GV1512H501	—	9GV1512P5H03	150 × 150 × 50 mm	Yes	200
9GV1512H5011	9GV1512H5021	9GV1512H5011	—	—	150 × 150 × 50 mm	No	200
9GV1512M501	9GV1512M502	9GV1512M501	—	9GV1512P5M03	150 × 150 × 50 mm	Yes	200
9GV1512M5011	9GV1512M5021	9GV1512M5011	—	9GV1512P5M011	150 × 150 × 50 mm	No	200
9GV1524M501	9GV1524M502	9GV1524M501	9GV1524M5D01	—	150 × 150 × 50 mm	Yes	200
9GV1524M5011	—	9GV1524M5011	—	—	150 × 150 × 50 mm	No	200
9GV2048P0G201	9GV2048G0202	—	—	9GV2048P0G201	∅200 × 70 mm	No	218
9GV3612G301	9GV3612G302	9GV3612G301	9GV3612G3D01	9GV3612P3G03	36 × 36 × 28 mm	Yes	16
9GV3612J301	9GV3612J302	9GV3612J301	9GV3612J3D01	9GV3612P3J03	36 × 36 × 28 mm	Yes	16
9GV5724H501	9GV5724H502	9GV5724H501	—	9GV5724P5H03	∅172 × 150 × 51 mm	No	210
9GV5748H501	9GV5748H502	9GV5748H501	—	9GV5748P5H01	∅172 × 150 × 51 mm	No	210
9GX3612P3K001	9GX3612K3002	—	—	9GX3612P3K001	36 × 36 × 28 mm	Yes	14
9HV0412P3K001	—	—	—	9HV0412P3K001	40 × 40 × 28 mm	No	42
9HV0612P1J001	—	—	—	9HV0612P1J001	60 × 60 × 38 mm	Yes	83
9HV0612P1J0011	—	—	—	9HV0612P1J0011	60 × 60 × 38 mm	No	83
9HV0812P1G601	9HV0812G1002	9HV0812G1001	—	9HV0812P1G601	80 × 80 × 38 mm	Yes	125
9HV0812P1G6011	9HV0812G10021	9HV0812G10011	—	9HV0812P1G6011	80 × 80 × 38 mm	No	125
9HV0824P1G003	—	—	9HV0824G1D001	9HV0824P1G003	80 × 80 × 38 mm	Yes	125
9HV0824P1G0011	—	—	—	9HV0824P1G0011	80 × 80 × 38 mm	No	125
9HV0848P1G001	9HV0848G1002	9HV0848G1001	9HV0848G1D001	9HV0848P1G001	80 × 80 × 38 mm	Yes	125
9HV0848P1G0011	9HV0848G10021	9HV0848G10011	—	9HV0848P1G0011	80 × 80 × 38 mm	No	125
9HV0912P1G001	—	—	—	9HV0912P1G001	92 × 92 × 38 mm	Yes	153
9HV0912P1G0011	—	—	—	9HV0912P1G0011	92 × 92 × 38 mm	No	153
9HV0924P1G001	—	—	—	9HV0924P1G001	92 × 92 × 38 mm	Yes	153
9HV0924P1G0011	—	—	—	9HV0924P1G0011	92 × 92 × 38 mm	No	153
9HV0948P1G001	—	—	—	9HV0948P1G001	92 × 92 × 38 mm	Yes	153

Note 1: For compliance with standards, see individual product pages. Please contact your point of sale regarding low-speed sensors.

Note 2: The  mark indicates Short Lead Time Service applicable models. See p. 654 for details.

Models listed in product pages	List of models (Below are optional models and not listed in product pages. Standard compliance of these optional models may differ from that of the models listed in product pages. Contact us for details of "-" models.)				Frame size	Rib	page
	Without sensor	With pulse sensor	With lock sensor	With PWM control function and pulse sensor			
	9HV0948P1G0011	—	—	—			
9HV0912P4G001	—	—	—	☞ 9HV0912P4G001	92 × 92 × 25 mm	Yes	137
9HV0912P4G0011	—	—	—	☞ 9HV0912P4G0011	92 × 92 × 25 mm	No	137
9HV0912P4H001	—	—	—	☞ 9HV0912P4H001	92 × 92 × 25 mm	Yes	137
9HV0912P4H0011	—	—	—	☞ 9HV0912P4H0011	92 × 92 × 25 mm	No	137
9HV0924P4G001	—	—	—	☞ 9HV0924P4G001	92 × 92 × 25 mm	Yes	137
9HV0924P4G0011	—	—	—	☞ 9HV0924P4G0011	92 × 92 × 25 mm	No	137
9HV0924P4H001	—	—	—	☞ 9HV0924P4H001	92 × 92 × 25 mm	Yes	137
9HV0924P4H0011	—	—	—	☞ 9HV0924P4H0011	92 × 92 × 25 mm	No	137
9HV1224P1A001	—	—	9HV1224A1D001	9HV1224P1A001	120 × 120 × 38 mm	No	178
9HV1248P1G001	9HV1248G1002	9HV1248G1001	9HV1248G1D001	☞ 9HV1248P1G001	120 × 120 × 38 mm	No	178
9HV1248P1H001	9HV1248H1002	9HV1248H1001	—	9HV1248P1H001	120 × 120 × 38 mm	No	178
9HV3612P3K001	—	—	—	☞ 9HV3612P3K001	36 × 36 × 28 mm	Yes	12
9HV5724P5H001	9HV5724H5002	9HV5724H5001	9HV5724H5D001	☞ 9HV5724P5H001	∅172 × 150 × 51 mm	No	205
9HV5748P5G001	—	—	—	☞ 9HV5748P5G001	∅172 × 150 × 51 mm	No	205
9HVA0412P3J001	—	—	—	☞ 9HVA0412P3J001	40 × 40 × 28 mm	Yes	37
9HVA0812P1G001	—	—	—	☞ 9HVA0812P1G001	80 × 80 × 38 mm	Yes	123
9HVA0812P1G0011	—	—	—	☞ 9HVA0812P1G0011	80 × 80 × 38 mm	No	123
9HVA0848P1G601	—	—	—	9HVA0848P1G601	80 × 80 × 38 mm	Yes	123
9HVA0848P1G6011	—	—	—	9HVA0848P1G6011	80 × 80 × 38 mm	No	123
9HVB0812P1G001	—	—	—	☞ 9HVB0812P1G001	80 × 80 × 38 mm	Yes	121
9HVB0812P1G0011	—	—	—	☞ 9HVB0812P1G0011	80 × 80 × 38 mm	No	121
9L0412H301	9L0412H302	9L0412H301	9L0412H3D01	—	40 × 40 × 28 mm	No	394
9L0412J301	9L0412J302	9L0412J301	9L0412J3D01	9L0412P3J01	40 × 40 × 28 mm	No	394
9L0412M301	9L0412M302	9L0412M301	9L0412M3D01	—	40 × 40 × 28 mm	No	394
9LG0612P4H001	9LG0612H4002	9LG0612H4001	9LG0612H4D001	☞ 9LG0612P4H001	60 × 60 × 25 mm	No	396
9LG0612P4J001	—	—	9LG0612J4D001	☞ 9LG0612P4J001	60 × 60 × 25 mm	No	396
9LG0612P4M001	—	—	9LG0612M4D001	☞ 9LG0612P4M001	60 × 60 × 25 mm	No	396
9LG0612P4S001	—	9LG0612S4001	9LG0612S4D001	☞ 9LG0612P4S001	60 × 60 × 25 mm	No	396
9LG0624P4H001	9LG0624H4002	9LG0624H4001	9LG0624H4D001	☞ 9LG0624P4H001	60 × 60 × 25 mm	No	396
9LG0624P4J001	—	—	—	☞ 9LG0624P4J001	60 × 60 × 25 mm	No	396
9LG0624P4M001	9LG0624M4002	9LG0624M4001	—	☞ 9LG0624P4M001	60 × 60 × 25 mm	No	396
9LG0624P4S001	9LG0624S4002	—	—	☞ 9LG0624P4S001	60 × 60 × 25 mm	No	396
9LG0648P4H001	—	—	—	☞ 9LG0648P4H001	60 × 60 × 25 mm	No	396
9LG0648P4J001	—	—	—	☞ 9LG0648P4J001	60 × 60 × 25 mm	No	396
9LG0648P4M001	—	—	—	☞ 9LG0648P4M001	60 × 60 × 25 mm	No	396
9LG0648P4S001	—	—	—	☞ 9LG0648P4S001	60 × 60 × 25 mm	No	396
9LG0812F4001	☞ 9LG0812F4002	☞ 9LG0812F4001	☞ 9LG0812F4D001	—	80 × 80 × 25 mm	No	405
9LG0812L4001	☞ 9LG0812L4002	☞ 9LG0812L4001	☞ 9LG0812L4D001	—	80 × 80 × 25 mm	No	405
9LG0812M4001	☞ 9LG0812M4002	☞ 9LG0812M4001	☞ 9LG0812M4D001	—	80 × 80 × 25 mm	No	405
9LG0812P4G001	—	9LG0812G4001	9LG0812G4D001	☞ 9LG0812P4G001	80 × 80 × 25 mm	No	405
9LG0812P4H001	☞ 9LG0812H4002	☞ 9LG0812H4001	☞ 9LG0812H4D001	☞ 9LG0812P4H001	80 × 80 × 25 mm	No	405
9LG0812P4J001	9LG0812J4002	—	9LG0812J4D001	☞ 9LG0812P4J001	80 × 80 × 25 mm	No	405
9LG0812S4001	☞ 9LG0812S4002	☞ 9LG0812S4001	☞ 9LG0812S4D001	—	80 × 80 × 25 mm	No	405
9LG0824F4001	☞ 9LG0824F4002	☞ 9LG0824F4001	☞ 9LG0824F4D001	—	80 × 80 × 25 mm	No	405
9LG0824L4001	☞ 9LG0824L4002	☞ 9LG0824L4001	☞ 9LG0824L4D001	—	80 × 80 × 25 mm	No	405
9LG0824M4001	☞ 9LG0824M4002	☞ 9LG0824M4001	☞ 9LG0824M4D001	—	80 × 80 × 25 mm	No	405
9LG0824P4G001	9LG0824G4002	9LG0824G4001	9LG0824G4D001	☞ 9LG0824P4G001	80 × 80 × 25 mm	No	405
9LG0824P4H001	☞ 9LG0824H4002	☞ 9LG0824H4001	☞ 9LG0824H4D001	☞ 9LG0824P4H001	80 × 80 × 25 mm	No	405
9LG0824P4J001	—	—	9LG0824J4D001	☞ 9LG0824P4J001	80 × 80 × 25 mm	No	405
9LG0824S4001	☞ 9LG0824S4002	☞ 9LG0824S4001	☞ 9LG0824S4D001	—	80 × 80 × 25 mm	No	405
9LG0912F4001	☞ 9LG0912F4002	☞ 9LG0912F4001	☞ 9LG0912F4D001	—	92 × 92 × 25 mm	No	412
9LG0912L4001	☞ 9LG0912L4002	☞ 9LG0912L4001	☞ 9LG0912L4D001	—	92 × 92 × 25 mm	No	412
9LG0912M4001	☞ 9LG0912M4002	☞ 9LG0912M4001	☞ 9LG0912M4D001	—	92 × 92 × 25 mm	No	412
9LG0912P1F001	—	—	—	☞ 9LG0912P1F001	92 × 92 × 38 mm	No	417
9LG0912P1H001	—	—	9LG0912H1D001	☞ 9LG0912P1H001	92 × 92 × 38 mm	No	417
9LG0912P4G001	9LG0912G4002	—	—	☞ 9LG0912P4G001	92 × 92 × 25 mm	No	412
9LG0912P4H001	☞ 9LG0912H4002	☞ 9LG0912H4001	☞ 9LG0912H4D001	☞ 9LG0912P4H001	92 × 92 × 25 mm	No	412
9LG0912P4J001	—	—	9LG0912J4D001	☞ 9LG0912P4J001	92 × 92 × 25 mm	No	412
9LG0912P4S001	☞ 9LG0912S4002	☞ 9LG0912S4001	☞ 9LG0912S4D001	☞ 9LG0912P4S001	92 × 92 × 25 mm	No	412
9LG0924F4001	☞ 9LG0924F4002	☞ 9LG0924F4001	☞ 9LG0924F4D001	—	92 × 92 × 25 mm	No	412

Note 1: For compliance with standards, see individual product pages. Please contact your point of sale regarding low-speed sensors.

Note 2: The ☞ mark indicates Short Lead Time Service applicable models. See p. 654 for details.

Models listed in product pages	List of models (Below are optional models and not listed in product pages. Standard compliance of these optional models may differ from that of the models listed in product pages. Contact us for details of "—" models.)				Frame size	Rib	page
	Without sensor	With pulse sensor	With lock sensor	With PWM control function and pulse sensor			
	9LG0924L4001	9LG0924L4002	9LG0924L4001	9LG0924L4D001			
9LG0924M4001	9LG0924M4002	9LG0924M4001	9LG0924M4D001	—	92 × 92 × 25 mm	No	412
9LG0924P1F001	—	—	—	9LG0924P1F001	92 × 92 × 38 mm	No	417
9LG0924P1H001	—	—	—	9LG0924P1H001	92 × 92 × 38 mm	No	417
9LG0924P4G001	—	—	—	9LG0924P4G001	92 × 92 × 25 mm	No	412
9LG0924P4H001	9LG0924H4002	9LG0924H4001	9LG0924H4D001	9LG0924P4H001	92 × 92 × 25 mm	No	412
9LG0924P4J001	—	—	9LG0924J4D001	9LG0924P4J001	92 × 92 × 25 mm	No	412
9LG0924P4S001	—	—	9LG0924S4D001	9LG0924P4S001	92 × 92 × 25 mm	No	412
9LG1212F1001	9LG1212F1002	9LG1212F1001	9LG1212F1D001	—	120 × 120 × 38 mm	No	420
9LG1212M1001	9LG1212M1002	9LG1212M1001	9LG1212M1D001	—	120 × 120 × 38 mm	No	420
9LG1212P1G001	—	—	—	9LG1212P1G001	120 × 120 × 38 mm	No	420
9LG1212P1H001	—	—	9LG1212H1D001	9LG1212P1H001	120 × 120 × 38 mm	No	420
9LG1212P1S001	—	—	—	9LG1212P1S001	120 × 120 × 38 mm	No	420
9LG1224A1001	9LG1224A1002	9LG1224A1001	9LG1224A1D001	—	120 × 120 × 38 mm	No	420
9LG1224F1001	9LG1224F1002	9LG1224F1001	9LG1224F1D001	—	120 × 120 × 38 mm	No	420
9LG1224M1001	9LG1224M1002	9LG1224M1001	9LG1224M1D001	—	120 × 120 × 38 mm	No	420
9LG1224P1G001	—	—	9LG1224G1D001	9LG1224P1G001	120 × 120 × 38 mm	No	420
9LG1224P1H001	—	9LG1224H1001	9LG1224H1D001	9LG1224P1H001	120 × 120 × 38 mm	No	420
9LG1224P1S001	—	9LG1224S1001	9LG1224S1D001	9LG1224P1S001	120 × 120 × 38 mm	No	420
9LG1248F1001	9LG1248F1002	9LG1248F1001	9LG1248F1D001	—	120 × 120 × 38 mm	No	420
9LG1248M1001	9LG1248M1002	9LG1248M1001	9LG1248M1D001	—	120 × 120 × 38 mm	No	420
9LG1248P1G001	9LG1248G1002	—	—	9LG1248P1G001	120 × 120 × 38 mm	No	420
9LG1248P1H001	—	—	—	9LG1248P1H001	120 × 120 × 38 mm	No	420
9LG1248P1S001	—	—	—	9LG1248P1S001	120 × 120 × 38 mm	No	420
9LG1412A5001	9LG1412A5002	9LG1412A5001	9LG1412A5D001	—	140 × 140 × 51 mm	No	433
9LG1412H5001	9LG1412H5002	9LG1412H5001	9LG1412H5D001	—	140 × 140 × 51 mm	No	433
9LG1412L1001	9LG1412L1002	9LG1412L1001	—	—	140 × 140 × 38 mm	No	428
9LG1412M5001	9LG1412M5002	9LG1412M5001	9LG1412M5D001	—	140 × 140 × 51 mm	No	433
9LG1412P1A001	—	—	—	9LG1412P1A001	140 × 140 × 38 mm	No	428
9LG1412P1H001	—	—	—	9LG1412P1H001	140 × 140 × 38 mm	No	428
9LG1412P1M001	9LG1412M1002	9LG1412M1001	9LG1412M1D001	9LG1412P1M001	140 × 140 × 38 mm	No	428
9LG1412P5G001	—	—	—	9LG1412P5G001	140 × 140 × 51 mm	No	433
9LG1412P5S001	9LG1412S5001	—	—	9LG1412P5S001	140 × 140 × 51 mm	No	433
9LG1424A5001	9LG1424A5002	9LG1424A5001	9LG1424A5D001	—	140 × 140 × 51 mm	No	433
9LG1424H5001	9LG1424H5002	9LG1424H5001	9LG1424H5D001	—	140 × 140 × 51 mm	No	433
9LG1424L1001	9LG1424L1002	9LG1424L1001	9LG1424L1D001	—	140 × 140 × 38 mm	No	428
9LG1424M5001	9LG1424M5002	9LG1424M5001	9LG1424M5D001	—	140 × 140 × 51 mm	No	433
9LG1424P1A001	—	—	—	9LG1424P1A001	140 × 140 × 38 mm	No	428
9LG1424P1H001	—	—	—	9LG1424P1H001	140 × 140 × 38 mm	No	428
9LG1424P1M001	9LG1424M1002	9LG1424M1001	9LG1424M1D001	9LG1424P1M001	140 × 140 × 38 mm	No	428
9LG1424P5G001	—	—	—	9LG1424P5G001	140 × 140 × 51 mm	No	433
9LG1424P5S001	9LG1424S5002	9LG1424S5001	9LG1424S5D001	9LG1424P5S001	140 × 140 × 51 mm	No	433
9LG1448A5001	9LG1448A5002	9LG1448A5001	9LG1448A5D001	—	140 × 140 × 51 mm	No	433
9LG1448H5001	9LG1448H5002	9LG1448H5001	9LG1448H5D001	—	140 × 140 × 51 mm	No	433
9LG1448L1001	9LG1448L1002	9LG1448L1001	9LG1448L1D001	—	140 × 140 × 38 mm	No	428
9LG1448M5001	9LG1448M5002	9LG1448M5001	9LG1448M5D001	—	140 × 140 × 51 mm	No	433
9LG1448P1A001	—	—	—	9LG1448P1A001	140 × 140 × 38 mm	No	428
9LG1448P1H001	—	—	—	9LG1448P1H001	140 × 140 × 38 mm	No	428
9LG1448P1M001	9LG1448M1002	9LG1448M1001	9LG1448M1D001	9LG1448P1M001	140 × 140 × 38 mm	No	428
9LG1448P5G001	—	—	—	9LG1448P5G001	140 × 140 × 51 mm	No	433
9LG1448P5S001	—	—	—	9LG1448P5S001	140 × 140 × 51 mm	No	433
9RF0912P1H001	—	—	—	9RF0912P1H001	92 × 38 mm	No	264
9RF0924P1H001	—	—	—	9RF0924P1H001	92 × 38 mm	No	264
9RF1312P3H001	—	—	—	9RF1312P3H001	136 × 28 mm	No	267
9RF1324P3H001	—	—	—	9RF1324P3H001	136 × 28 mm	No	267
9S0612F401	9S0612F402	9S0612F401	9S0612F4D01	9S0612P4F01	60 × 60 × 25 mm	Yes	78
9S0612F4011	9S0612F4021	9S0612F4011	9S0612F4D011	9S0612P4F011	60 × 60 × 25 mm	No	78
9S0612H401	9S0612H402	9S0612H401	9S0612H4D01	9S0612P4H01	60 × 60 × 25 mm	Yes	78
9S0612H4011	9S0612H4021	9S0612H4011	9S0612H4D011	9S0612P4H011	60 × 60 × 25 mm	No	78
9S0612M401	9S0612M402	9S0612M401	9S0612M4D01	9S0612P4M01	60 × 60 × 25 mm	Yes	78
9S0612M4011	9S0612M4021	9S0612M4011	9S0612M4D011	—	60 × 60 × 25 mm	No	78

Note 1: For compliance with standards, see individual product pages. Please contact your point of sale regarding low-speed sensors.

Note 2: The  mark indicates Short Lead Time Service applicable models. See p. 654 for details.

Models listed in product pages	List of models (Below are optional models and not listed in product pages. Standard compliance of these optional models may differ from that of the models listed in product pages. Contact us for details of "—" models.)				Frame size	Rib	page
	Without sensor	With pulse sensor	With lock sensor	With PWM control function and pulse sensor			
	9S0612S401	9S0612S402	➤ 9S0612S401	9S0612S4D01			
9S0612S4011	—	9S0612S4011	—	9S0612P4S011	60 × 60 × 25 mm	No	78
9S0812F401	9S0812F402	➤ 9S0812F401	9S0812F4D01	➤ 9S0812P4F01	80 × 80 × 25 mm	Yes	112
9S0812F4011	9S0812F4021	9S0812F4011	9S0812F4D011	9S0812P4F011	80 × 80 × 25 mm	No	112
9S0812H401	9S0812H402	➤ 9S0812H401	9S0812H4D01	—	80 × 80 × 25 mm	Yes	112
9S0812H4011	—	9S0812H4011	9S0812H4D011	—	80 × 80 × 25 mm	No	112
9S0812L401	9S0812L402	➤ 9S0812L401	9S0812L4D01	—	80 × 80 × 25 mm	Yes	112
9S0812L4011	9S0812L4021	9S0812L4011	9S0812L4D011	—	80 × 80 × 25 mm	No	112
9S0812M401	9S0812M402	➤ 9S0812M401	9S0812M4D01	9S0812P4M01	80 × 80 × 25 mm	Yes	112
9S0812M4011	9S0812M4021	9S0812M4011	9S0812M4D011	9S0812P4M011	80 × 80 × 25 mm	No	112
9S0824L401	➤ 9S0824L402	➤ 9S0824L401	9S0824L4D01	—	80 × 80 × 25 mm	Yes	112
9S0824L4011	9S0824L4021	9S0824L4011	9S0824L4D011	—	80 × 80 × 25 mm	No	112
9S0824M401	9S0824M402	➤ 9S0824M401	9S0824M4D01	—	80 × 80 × 25 mm	Yes	112
9S0824M4011	9S0824M4021	9S0824M4011	9S0824M4D011	—	80 × 80 × 25 mm	No	112
9S0912F401	9S0912F402	➤ 9S0912F401	9S0912F4D01	➤ 9S0912P4F01	92 × 92 × 25 mm	Yes	145
9S0912F4011	9S0912F4021	9S0912F4011	9S0912F4D011	9S0912P4F011	92 × 92 × 25 mm	No	145
9S0912L401	9S0912L402	➤ 9S0912L401	9S0912L4D01	—	92 × 92 × 25 mm	Yes	145
9S0912L4011	9S0912L4021	9S0912L4011	9S0912L4D011	—	92 × 92 × 25 mm	No	145
9S0912M401	9S0912M402	➤ 9S0912M401	9S0912M4D01	9S0912P4M01	92 × 92 × 25 mm	Yes	145
9S0912M4011	9S0912M4021	9S0912M4011	9S0912M4D011	9S0912P4M011	92 × 92 × 25 mm	No	145
9S0924F401	9S0924F402	➤ 9S0924F401	9S0924F4D01	—	92 × 92 × 25 mm	Yes	145
9S0924F4011	9S0924F4021	9S0924F4011	—	—	92 × 92 × 25 mm	No	145
9S0924L401	9S0924L402	➤ 9S0924L401	9S0924L4D01	—	92 × 92 × 25 mm	Yes	145
9S0924L4011	9S0924L4021	9S0924L4011	—	—	92 × 92 × 25 mm	No	145
9S0924M401	9S0924M402	➤ 9S0924M401	9S0924M4D01	—	92 × 92 × 25 mm	Yes	145
9S0924M4011	9S0924M4021	9S0924M4011	—	—	92 × 92 × 25 mm	No	145
9S1212F401	9S1212F402	➤ 9S1212F401	9S1212F4D01	9S1212P4F01	120 × 120 × 25 mm	Yes	176
9S1212F4011	9S1212F4021	9S1212F4011	9S1212F4D011	9S1212P4F011	120 × 120 × 25 mm	No	176
9S1212H401	9S1212H402	➤ 9S1212H401	9S1212H4D01	➤ 9S1212P4H01	120 × 120 × 25 mm	Yes	176
9S1212H4011	9S1212H4021	9S1212H4011	—	9S1212P4H011	120 × 120 × 25 mm	No	176
9S1212L401	9S1212L402	➤ 9S1212L401	9S1212L4D01	—	120 × 120 × 25 mm	Yes	176
9S1212L4011	9S1212L4021	9S1212L4011	9S1212L4D011	9S1212P4L011	120 × 120 × 25 mm	No	176
9S1212M401	9S1212M402	➤ 9S1212M401	9S1212M4D01	9S1212P4M01	120 × 120 × 25 mm	Yes	176
9S1212M4011	9S1212M4021	9S1212M4011	9S1212M4D011	9S1212P4M011	120 × 120 × 25 mm	No	176
9S1224M401	➤ 9S1224M402	➤ 9S1224M401	9S1224M4D01	—	120 × 120 × 25 mm	Yes	176
9S1224M4011	9S1224M4021	9S1224M4011	9S1224M4D011	—	120 × 120 × 25 mm	No	176
9SG1212G101	➤ 9SG1212G102	➤ 9SG1212G101	9SG1212G1D01	➤ 9SG1212P1G01	120 × 120 × 38 mm	No	184
9SG1224G101	➤ 9SG1224G102	➤ 9SG1224G101	➤ 9SG1224G1D01	➤ 9SG1224P1G01	120 × 120 × 38 mm	No	184
9SG1224H101	9SG1224H102	9SG1224H101	9SG1224H1D01	—	120 × 120 × 38 mm	No	184
9SG1248G101	9SG1248G102	➤ 9SG1248G101	—	➤ 9SG1248P1G01	120 × 120 × 38 mm	No	184
9SG5724P5H61	9SG5724H562	—	—	➤ 9SG5724P5H61	∅172 × 150 × 51 mm	No	207
9SG5748P5G01	—	—	—	➤ 9SG5748P5G01	∅172 × 150 × 51 mm	No	207
9SG5748P5H01	—	—	—	➤ 9SG5748P5H01	∅172 × 150 × 51 mm	No	207
9TD12P6G001	—	—	—	9TD12P6G001	∅70 × 20 mm	No	464
9TG24P0G01	9TG24G002	9TG24G001	—	9TG24P0G01	∅175 × 69 mm	—	476
9TG24P0S01	9TG24S002	9TG24S001	—	9TG24P0S01	∅175 × 69 mm	—	476
9TG48P0G01	—	—	—	9TG48P0G01	∅175 × 69 mm	—	476
9TGA24P0H001	—	—	—	9TGA24P0H001	∅175 × 69 mm	—	473
9TGA48P0G001	—	—	—	9TGA48P0G001	∅175 × 69 mm	—	473
9TJ24P0H61	—	—	—	9TJ24P0H61	∅133 × 91 mm	—	469
9TJ48P0H01	—	—	—	9TJ48P0H01	∅133 × 91 mm	—	469
9TM24P4H01	—	—	—	9TM24P4H01	∅100 × 25 mm	—	466
9TM48P4H01	9TM48H402	—	—	9TM48P4H01	∅100 × 25 mm	—	466
9TN24P1H01	—	—	—	9TN24P1H01	∅150 × 35 mm	—	471
9TN48P1H01	—	—	—	9TN48P1H01	∅150 × 35 mm	—	471
9TP24P0H001	—	—	—	9TP24P0H001	∅221 × 71 mm	—	479
9TP48P0G001	9TP48G0002	—	—	9TP48P0G001	∅221 × 71 mm	—	479
9TP48P0H001	—	—	—	9TP48P0H001	∅221 × 71 mm	—	479
9TS48P0G001	—	—	—	9TS48P0G001	∅225 × 99 mm	—	482
9TS48P0H001	—	—	—	9TS48P0H001	∅225 × 99 mm	—	482
9W1BM12P2H001	—	—	—	9W1BM12P2H001	97 × 33 mm	—	360

Note 1: For compliance with standards, see individual product pages. Please contact your point of sale regarding low-speed sensors.

Note 2: The ➤ mark indicates Short Lead Time Service applicable models. See p. 654 for details.

Models listed in product pages	List of models (Below are optional models and not listed in product pages. Standard compliance of these optional models may differ from that of the models listed in product pages. Contact us for details of "-" models.)				Frame size	Rib	page
	Without sensor	With pulse sensor	With lock sensor	With PWM control function and pulse sensor			
	9W1BM12P2M001	—	—	—			
9W1BM24P2H001	—	—	—	9W1BM24P2H001	97 × 33 mm	—	360
9W1BM24P2M001	—	—	—	9W1BM24P2M001	97 × 33 mm	—	360
9W1TG48P0H61	—	—	—	9W1TG48P0H61	∅175 × 69 mm	—	346
9W1TJ24P0H61	—	—	—	9W1TJ24P0H61	∅133 × 91 mm	—	337
9W1TJ48P0H61	—	—	—	9W1TJ48P0H61	∅133 × 91 mm	—	337
9W1TM48P4G01	—	—	—	9W1TM48P4G01	∅100 × 25 mm	—	334
9W1TM48P4H01	—	—	—	9W1TM48P4H01	∅100 × 25 mm	—	334
9W1TN48P1H01	—	—	—	9W1TN48P1H01	∅150 × 35 mm	—	342
9W2TGA48P0G001	—	—	—	9W2TGA48P0G001	∅175 × 69 mm	—	344
9W2TN24P1H001	—	—	—	9W2TN24P1H001	∅150 × 35 mm	—	339
9W2TN48P1H001	—	—	—	9W2TN48P1H001	∅150 × 35 mm	—	339
9W2TP24P0H001	—	—	—	9W2TP24P0H001	∅221 × 71 mm	—	348
9W2TP48P0S001	—	—	—	9W2TP48P0S001	∅221 × 71 mm	—	348
9W2TS48P0S001	—	—	—	9W2TS48P0S001	∅225 × 99 mm	—	351
9WE1724K501	9WE1724K502	9WE1724K501	—	—	∅172 × 51 mm	No	330
9WE5724K501	9WE5724K502	9WE5724K501	—	—	∅172 × 150 × 51 mm	No	328
9WE5748K501	9WE5748K502	9WE5748K501	9WE5748K5D01	9WE5748P5K01	∅172 × 150 × 51 mm	No	328
9WF0424F601	9WF0424F602	9WF0424F601	9WF0424F6D01	—	40 × 40 × 20 mm	Yes	368
9WF0424H601	9WF0424H602	9WF0424H601	9WF0424H6D01	—	40 × 40 × 20 mm	Yes	368
9WF0424H701	9WF0424H702	9WF0424H701	9WF0424H7D01	—	40 × 40 × 15 mm	Yes	364
9WF0624H401	9WF0624H402	9WF0624H401	9WF0624H4D01	—	60 × 60 × 25 mm	Yes	376
9WF0624H601	—	9WF0624H601	9WF0624H6D01	—	60 × 60 × 20 mm	Yes	374
9WF0624H701	9WF0624H702	9WF0624H701	9WF0624H7D01	—	60 × 60 × 15 mm	Yes	370
9WF0824S401	9WF0824S402	9WF0824S401	9WF0824S4D01	—	80 × 80 × 25 mm	Yes	380
9WF0924H201	9WF0924H202	9WF0924H201	9WF0924H2D01	—	92 × 92 × 32 mm	Yes	388
9WF0924H2011	—	9WF0924H2011	—	—	92 × 92 × 32 mm	No	388
9WF0924H401	9WF0924H402	9WF0924H401	9WF0924H4D01	—	92 × 92 × 25 mm	Yes	384
9WF0924H4011	—	9WF0924H4011	9WF0924H4D011	—	92 × 92 × 25 mm	No	384
9WF0924S201	9WF0924S202	9WF0924S201	9WF0924S2D01	—	92 × 92 × 32 mm	Yes	388
9WF0924S2011	—	9WF0924S2011	—	—	92 × 92 × 32 mm	No	388
9WF1224H101	9WF1224H102	9WF1224H101	9WF1224H1D01	—	120 × 120 × 38 mm	Yes	390
9WFA0424G6001	9WFA0424G6002	9WFA0424G6001	9WFA0424G6D001	9WFA0424P6G001	40 × 40 × 20 mm	Yes	366
9WFA0624G6001	9WFA0624G6002	9WFA0624G6001	9WFA0624G6D001	9WFA0624P6G001	60 × 60 × 20 mm	Yes	372
9WFA0824G6001	9WFA0824G6002	9WFA0824G6001	9WFA0824G6D001	9WFA0824P6G001	80 × 80 × 20 mm	Yes	378
9WFA0924G2001	9WFA0924G2002	9WFA0924G2001	9WFA0924G2D001	9WFA0924P2G001	92 × 92 × 32 mm	Yes	386
9WFA0924G4001	—	9WFA0924G4001	—	9WFA0924P4G001	92 × 92 × 25 mm	Yes	382
9WFA0924G40011	—	9WFA0924G40011	—	9WFA0924P4G0011	92 × 92 × 25 mm	No	382
9WFA0924H4001	—	9WFA0924H4001	—	9WFA0924P4H001	92 × 92 × 25 mm	Yes	382
9WFA0924H40011	—	9WFA0924H40011	—	9WFA0924P4H0011	92 × 92 × 25 mm	No	382
9WG1212E101-E	9WG1212E102-E	9WG1212E101-E	9WG1212E1D01-E	—	120 × 120 × 38 mm	No	310
9WG1212F101-E	9WG1212F102-E	9WG1212F101-E	9WG1212F1D01-E	—	120 × 120 × 38 mm	No	310
9WG1212G101-E	9WG1212G102-E	9WG1212G101-E	9WG1212G1D01-E	—	120 × 120 × 38 mm	No	310
9WG1212H101-E	9WG1212H102-E	9WG1212H101-E	9WG1212H1D01-E	—	120 × 120 × 38 mm	No	310
9WG1212M101-E	9WG1212M102-E	9WG1212M101-E	9WG1212M1D01-E	—	120 × 120 × 38 mm	No	310
9WG1224E101-E	9WG1224E102-E	9WG1224E101-E	9WG1224E1D01-E	—	120 × 120 × 38 mm	No	310
9WG1224F101-E	9WG1224F102-E	9WG1224F101-E	9WG1224F1D01-E	—	120 × 120 × 38 mm	No	310
9WG1224G101-E	9WG1224G102-E	9WG1224G101-E	9WG1224G1D01-E	—	120 × 120 × 38 mm	No	310
9WG1224H101-E	9WG1224H102-E	9WG1224H101-E	9WG1224H1D01-E	—	120 × 120 × 38 mm	No	310
9WG1224M101-E	9WG1224M102-E	9WG1224M101-E	9WG1224M1D01-E	—	120 × 120 × 38 mm	No	310
9WG1248E101-E	9WG1248E102-E	9WG1248E101-E	9WG1248E1D01-E	—	120 × 120 × 38 mm	No	310
9WG1248F101-E	9WG1248F102-E	9WG1248F101-E	9WG1248F1D01-E	—	120 × 120 × 38 mm	No	310
9WG1248G101-E	9WG1248G102-E	9WG1248G101-E	9WG1248G1D01-E	—	120 × 120 × 38 mm	No	310
9WG1248H101-E	9WG1248H102-E	9WG1248H101-E	9WG1248H1D01-E	—	120 × 120 × 38 mm	No	310
9WG1248M101-E	9WG1248M102-E	9WG1248M101-E	9WG1248M1D01-E	—	120 × 120 × 38 mm	No	310
9WG5748P5G001	9WG5748G5002	—	—	9WG5748P5G001	∅172 × 150 × 51 mm	No	326
9WG5748P5H001	9WG5748H5002	9WG5748H5001	9WG5748H5D001	9WG5748P5H001	∅172 × 150 × 51 mm	No	326
9WL0412P3G001	9WL0412G3002	9WL0412G3001	9WL0412G3D001	9WL0412P3G001	40 × 40 × 28 mm	No	272
9WL0412P3J001	9WL0412J3002	9WL0412J3001	—	9WL0412P3J001	40 × 40 × 28 mm	No	272
9WL0424P3G001	9WL0424G3002	9WL0424G3001	—	9WL0424P3G001	40 × 40 × 28 mm	No	272
9WL0424P3J001	9WL0424J3002	9WL0424J3001	—	9WL0424P3J001	40 × 40 × 28 mm	No	272

Note 1: For compliance with standards, see individual product pages. Please contact your point of sale regarding low-speed sensors.

Note 2: The  mark indicates Short Lead Time Service applicable models. See p. 654 for details.

Models listed in product pages	List of models (Below are optional models and not listed in product pages. Standard compliance of these optional models may differ from that of the models listed in product pages. Contact us for details of "—" models.)				Frame size	Rib	page
	Without sensor	With pulse sensor	With lock sensor	With PWM control function and pulse sensor			
	9WL0612P4H001	9WL0612H4002	—	—			
9WL0612P4J001	9WL0612J4002	—	9WL0612J4D001	9WL0612P4J001	60 × 60 × 25 mm	No	277
9WL0612P4S001	9WL0612S4002	—	9WL0612S4D001	9WL0612P4S001	60 × 60 × 25 mm	No	277
9WL0624P4H001	—	9WL0624H4001	—	9WL0624P4H001	60 × 60 × 25 mm	No	277
9WL0624P4J001	—	—	9WL0624J4D001	9WL0624P4J001	60 × 60 × 25 mm	No	277
9WL0624P4S001	9WL0624S4002	9WL0624S4001	—	9WL0624P4S001	60 × 60 × 25 mm	No	277
9WL0812L4001	9WL0812L4002	9WL0812L4001	—	—	80 × 80 × 25 mm	No	285
9WL0812P4G001	—	—	9WL0812G4D001	9WL0812P4G001	80 × 80 × 25 mm	No	285
9WL0812P4H001	9WL0812H4002	9WL0812H4001	9WL0812H4D001	9WL0812P4H001	80 × 80 × 25 mm	No	285
9WL0812P4J001	—	—	—	9WL0812P4J001	80 × 80 × 25 mm	No	285
9WL0824F4001	9WL0824F4002	9WL0824F4001	—	—	80 × 80 × 25 mm	No	285
9WL0824L4001	9WL0824L4002	9WL0824L4001	—	—	80 × 80 × 25 mm	No	285
9WL0824P4G001	—	—	—	9WL0824P4G001	80 × 80 × 25 mm	No	285
9WL0824P4H001	9WL0824H4002	9WL0824H4001	9WL0824H4D001	9WL0824P4H001	80 × 80 × 25 mm	No	285
9WL0824P4J001	9WL0824J4002	—	—	9WL0824P4J001	80 × 80 × 25 mm	No	285
9WL0912M4001	9WL0912M4002	9WL0912M4001	—	—	92 × 92 × 25 mm	No	295
9WL0912P1F001	—	—	—	9WL0912P1F001	92 × 92 × 38 mm	No	302
9WL0912P1H001	—	—	—	9WL0912P1H001	92 × 92 × 38 mm	No	302
9WL0912P4G001	—	—	—	9WL0912P4G001	92 × 92 × 25 mm	No	295
9WL0912P4H001	9WL0912H4002	9WL0912H4001	9WL0912H4D001	9WL0912P4H001	92 × 92 × 25 mm	No	295
9WL0912P4J001	9WL0912J4002	—	—	9WL0912P4J001	92 × 92 × 25 mm	No	295
9WL0912P4S001	—	—	—	9WL0912P4S001	92 × 92 × 25 mm	No	295
9WL0924F4001	9WL0924F4002	9WL0924F4001	—	—	92 × 92 × 25 mm	No	295
9WL0924M4001	9WL0924M4002	9WL0924M4001	9WL0924M4D001	—	92 × 92 × 25 mm	No	295
9WL0924P1F001	9WL0924F1002	—	—	9WL0924P1F001	92 × 92 × 38 mm	No	302
9WL0924P1H001	—	—	—	9WL0924P1H001	92 × 92 × 38 mm	No	302
9WL0924P4H001	9WL0924H4002	9WL0924H4001	9WL0924H4D001	9WL0924P4H001	92 × 92 × 25 mm	No	295
9WL0924P4J001	—	—	—	9WL0924P4J001	92 × 92 × 25 mm	No	295
9WL0924P4S001	—	—	—	9WL0924P4S001	92 × 92 × 25 mm	No	295
9WL0948P1F601	—	—	—	9WL0948P1F601	92 × 92 × 38 mm	No	302
9WL0948P1H601	—	—	—	9WL0948P1H601	92 × 92 × 38 mm	No	302
9WL1412P1A001	—	—	—	9WL1412P1A001	140 × 140 × 38 mm	No	316
9WL1412P1H001	—	—	—	9WL1412P1H001	140 × 140 × 38 mm	No	316
9WL1412P1M001	9WL1412M1002	9WL1412M1001	9WL1412M1D001	9WL1412P1M001	140 × 140 × 38 mm	No	316
9WL1412A5001	9WL1412A5002	9WL1412A5001	9WL1412A5D001	—	140 × 140 × 51 mm	No	321
9WL1412H5001	9WL1412H5002	9WL1412H5001	9WL1412H5D001	—	140 × 140 × 51 mm	No	321
9WL1412M5001	9WL1412M5002	9WL1412M5001	9WL1412M5D001	—	140 × 140 × 51 mm	No	321
9WL1412P5G001	—	—	9WL1412G5D001	9WL1412P5G001	140 × 140 × 51 mm	No	321
9WL1412P5S001	—	—	—	9WL1412P5S001	140 × 140 × 51 mm	No	321
9WL1424P1A001	—	—	—	9WL1424P1A001	140 × 140 × 38 mm	No	316
9WL1424P1H001	—	—	—	9WL1424P1H001	140 × 140 × 38 mm	No	316
9WL1424P1M001	9WL1424M1002	9WL1424M1001	9WL1424M1D001	9WL1424P1M001	140 × 140 × 38 mm	No	316
9WL1424A5001	9WL1424A5002	9WL1424A5001	9WL1424A5D001	—	140 × 140 × 51 mm	No	321
9WL1424H5001	9WL1424H5002	9WL1424H5001	9WL1424H5D001	—	140 × 140 × 51 mm	No	321
9WL1424M5001	9WL1424M5002	9WL1424M5001	9WL1424M5D001	—	140 × 140 × 51 mm	No	321
9WL1424P5G001	—	9WL1424G5001	—	9WL1424P5G001	140 × 140 × 51 mm	No	321
9WL1424P5S001	—	—	—	9WL1424P5S001	140 × 140 × 51 mm	No	321
9WL1448A5001	9WL1448A5002	9WL1448A5001	9WL1448A5D001	—	140 × 140 × 51 mm	No	321
9WL1448H5001	9WL1448H5002	9WL1448H5001	9WL1448H5D001	—	140 × 140 × 51 mm	No	321
9WL1448L1001	9WL1448L1002	9WL1448L1001	9WL1448L1D001	—	140 × 140 × 38 mm	No	316
9WL1448M5001	9WL1448M5002	9WL1448M5001	9WL1448M5D001	—	140 × 140 × 51 mm	No	321
9WL1448P1A001	—	—	—	9WL1448P1A001	140 × 140 × 38 mm	No	316
9WL1448P1H001	—	—	—	9WL1448P1H001	140 × 140 × 38 mm	No	316
9WL1448P1M001	9WL1448M1002	9WL1448M1001	9WL1448M1D001	9WL1448P1M001	140 × 140 × 38 mm	No	316
9WL1448P5G001	—	—	—	9WL1448P5G001	140 × 140 × 51 mm	No	321
9WL1448P5S001	—	—	—	9WL1448P5S001	140 × 140 × 51 mm	No	321
9WP0412F6001	9WP0412F6002	9WP0412F6001	9WP0412F6D001	—	40 × 40 × 20 mm	Yes	270
9WP0412H6001	9WP0412H6002	9WP0412H6001	—	—	40 × 40 × 20 mm	Yes	270
9WP0612D401	9WP0612D402	9WP0612D401	9WP0612D4D01	—	60 × 60 × 25 mm	Yes	280
9WP0612D4011	—	9WP0612D4011	9WP0612D4D011	—	60 × 60 × 25 mm	No	280
9WP0612G401	9WP0612G402	9WP0612G401	9WP0612G4D01	9WP0612P4G01	60 × 60 × 25 mm	Yes	280

Note 1: For compliance with standards, see individual product pages. Please contact your point of sale regarding low-speed sensors.

Note 2: The  mark indicates Short Lead Time Service applicable models. See p. 654 for details.

Models listed in product pages	List of models (Below are optional models and not listed in product pages. Standard compliance of these optional models may differ from that of the models listed in product pages. Contact us for details of "—" models.)				Frame size	Rib	page
	Without sensor	With pulse sensor	With lock sensor	With PWM control function and pulse sensor			
	9WP0612G4011	9WP0612G4021	9WP0612G4011	—			
9WP0612H401	9WP0612H402	9WP0612H401	9WP0612H4D01	—	60 × 60 × 25 mm	Yes	280
9WP0612H4011	9WP0612H4021	9WP0612H4011	9WP0612H4D011	—	60 × 60 × 25 mm	No	280
9WP0624G401	9WP0624G402	9WP0624G401	9WP0624G4D01	—	60 × 60 × 25 mm	Yes	280
9WP0624G4011	—	9WP0624G4011	—	—	60 × 60 × 25 mm	No	280
9WP0624H401	9WP0624H402	9WP0624H401	9WP0624H4D01	—	60 × 60 × 25 mm	Yes	280
9WP0624H4011	9WP0624H4021	9WP0624H4011	9WP0624H4D011	—	60 × 60 × 25 mm	No	280
9WP0624J401	9WP0624J402	9WP0624J401	—	—	60 × 60 × 25 mm	Yes	280
9WP0624J4011	—	9WP0624J4011	—	—	60 × 60 × 25 mm	No	280
9WP0648H401	9WP0648H402	9WP0648H401	9WP0648H4D01	—	60 × 60 × 25 mm	Yes	280
9WP0648H4011	9WP0648H4021	9WP0648H4011	9WP0648H4D011	—	60 × 60 × 25 mm	No	280
9WP0812G401	9WP0812G402	9WP0812G401	9WP0812G4D01	9WP0812P4G01	80 × 80 × 25 mm	Yes	289
9WP0812G4011	9WP0812G4021	9WP0812G4011	9WP0812G4D011	—	80 × 80 × 25 mm	No	289
9WP0812H401	9WP0812H402	9WP0812H401	9WP0812H4D01	—	80 × 80 × 25 mm	Yes	289
9WP0812H4011	9WP0812H4021	9WP0812H4011	9WP0812H4D011	—	80 × 80 × 25 mm	No	289
9WP0824H401	9WP0824H402	9WP0824H401	9WP0824H4D01	—	80 × 80 × 25 mm	Yes	289
9WP0824H4011	9WP0824H4021	9WP0824H4011	9WP0824H4D011	—	80 × 80 × 25 mm	No	289
9WP0824S401	9WP0824S402	9WP0824S401	9WP0824S4D01	—	80 × 80 × 25 mm	Yes	289
9WP0824S4011	9WP0824S4021	9WP0824S4011	—	—	80 × 80 × 25 mm	No	289
9WP0848S401	9WP0848S402	9WP0848S401	9WP0848S4D01	—	80 × 80 × 25 mm	Yes	289
9WP0848S4011	9WP0848S4021	9WP0848S4011	9WP0848S4D011	—	80 × 80 × 25 mm	No	289
9WP0912F401	9WP0912F402	9WP0912F401	9WP0912F4D01	—	92 × 92 × 25 mm	Yes	299
9WP0912F4011	—	9WP0912F4011	9WP0912F4D011	—	92 × 92 × 25 mm	No	299
9WP0912S401	9WP0912S402	9WP0912S401	9WP0912S4D01	—	92 × 92 × 25 mm	Yes	299
9WP0912S4011	—	9WP0912S4011	—	—	92 × 92 × 25 mm	No	299
9WP0924B401	9WP0924B402	9WP0924B401	9WP0924B4D01	—	92 × 92 × 25 mm	Yes	299
9WP0924B4011	9WP0924B4021	9WP0924B4011	9WP0924B4D011	—	92 × 92 × 25 mm	No	299
9WP0924F401	9WP0924F402	9WP0924F401	9WP0924F4D01	—	92 × 92 × 25 mm	Yes	299
9WP0924F4011	9WP0924F4021	9WP0924F4011	9WP0924F4D011	—	92 × 92 × 25 mm	No	299
9WP0924G401	9WP0924G402	9WP0924G401	9WP0924G4D01	—	92 × 92 × 25 mm	Yes	299
9WP0924G4011	—	9WP0924G4011	—	—	92 × 92 × 25 mm	No	299
9WP0924H401	9WP0924H402	9WP0924H401	9WP0924H4D01	—	92 × 92 × 25 mm	Yes	299
9WP0924H4011	—	9WP0924H4011	—	—	92 × 92 × 25 mm	No	299
9WP0924S401	9WP0924S402	9WP0924S401	9WP0924S4D01	—	92 × 92 × 25 mm	Yes	299
9WP0924S4011	—	9WP0924S4011	—	—	92 × 92 × 25 mm	No	299
9WP1212H101	9WP1212H102	9WP1212H101	9WP1212H1D01	—	120 × 120 × 38 mm	Yes	313
9WP1212H1011	9WP1212H1021	9WP1212H1011	9WP1212H1D011	—	120 × 120 × 38 mm	No	313
9WP1212L101	9WP1212L102	9WP1212L101	—	—	120 × 120 × 38 mm	Yes	313
9WP1212L1011	—	9WP1212L1011	—	—	120 × 120 × 38 mm	No	313
9WP1212M101	9WP1212M102	9WP1212M101	—	—	120 × 120 × 38 mm	Yes	313
9WP1212M1011	9WP1212M1021	9WP1212M1011	—	—	120 × 120 × 38 mm	No	313
9WP1224H101	9WP1224H102	9WP1224H101	9WP1224H1D01	—	120 × 120 × 38 mm	Yes	313
9WP1224H1011	9WP1224H1021	9WP1224H1011	9WP1224H1D011	—	120 × 120 × 38 mm	No	313
9WP1224M101	9WP1224M102	9WP1224M101	—	—	120 × 120 × 38 mm	Yes	313
9WP1224M1011	9WP1224M1021	9WP1224M1011	—	—	120 × 120 × 38 mm	No	313
9WP1248H101	9WP1248H102	9WP1248H101	9WP1248H1D01	—	120 × 120 × 38 mm	Yes	313
9WP1248H1011	9WP1248H1021	9WP1248H1011	9WP1248H1D011	—	120 × 120 × 38 mm	No	313
9WP1248M101	9WP1248M102	9WP1248M101	9WP1248M1D01	—	120 × 120 × 38 mm	Yes	313
9WP1248M1011	9WP1248M1021	9WP1248M1011	9WP1248M1D011	—	120 × 120 × 38 mm	No	313
9WPA0612P4G001	9WPA0612G4002	9WPA0612G4001	9WPA0612G4D001	9WPA0612P4G001	60 × 60 × 25 mm	Yes	275
9WPA0612P4G0011	—	—	—	9WPA0612P4G0011	60 × 60 × 25 mm	No	275
9WPA0624P4G001	9WPA0624G4002	9WPA0624G4001	9WPA0624G4D001	9WPA0624P4G001	60 × 60 × 25 mm	Yes	275
9WPA0624P4G0011	—	—	—	9WPA0624P4G0011	60 × 60 × 25 mm	No	275
9WPA0812P4G001	9WPA0812G4002	9WPA0812G4001	9WPA0812G4D001	9WPA0812P4G001	80 × 80 × 25 mm	Yes	283
9WPA0812P4G0011	—	—	—	9WPA0812P4G0011	80 × 80 × 25 mm	No	283
9WPA0824P4G001	9WPA0824G4002	9WPA0824G4001	9WPA0824G4D001	9WPA0824P4G001	80 × 80 × 25 mm	Yes	283
9WPA0824P4G0011	—	—	—	9WPA0824P4G0011	80 × 80 × 25 mm	No	283
9WPA0912P4G001	—	—	—	9WPA0912P4G001	92 × 92 × 25 mm	Yes	293
9WPA0912P4G0011	—	—	—	9WPA0912P4G0011	92 × 92 × 25 mm	No	293
9WPA0924P4G001	—	—	—	9WPA0924P4G001	92 × 92 × 25 mm	Yes	293
9WPA0924P4G0011	—	—	—	9WPA0924P4G0011	92 × 92 × 25 mm	No	293

Note 1: For compliance with standards, see individual product pages. Please contact your point of sale regarding low-speed sensors.

Note 2: The  mark indicates Short Lead Time Service applicable models. See p. 654 for details.

Models listed in product pages	List of models (Below are optional models and not listed in product pages. Standard compliance of these optional models may differ from that of the models listed in product pages. Contact us for details of "—" models.)				Frame size	Rib	page
	Without sensor	With pulse sensor	With lock sensor	With PWM control function and pulse sensor			
	9WV0812P1M001	—	9WV0812M1001	9WV0812M1D001			
9WV0812P1M0011	—	—	—	9WV0812P1M0011	80 × 80 × 38 mm	No	291
9WV0848P1H001	—	—	—	9WV0848P1H001	80 × 80 × 38 mm	Yes	291
9WV0848P1H0011	—	—	—	9WV0848P1H0011	80 × 80 × 38 mm	No	291
9WV0924P1H001	9WV0924H1002	—	—	9WV0924P1H001	92 × 92 × 38 mm	Yes	305
9WV0948P1H001	—	—	—	9WV0948P1H001	92 × 92 × 38 mm	Yes	305
9WV1212P1J001	9WV1212J1002	—	9WV1212J1D001	9WV1212P1J001	120 × 120 × 38 mm	No	307
9WV1224P1H001	9WV1224H102	9WV1224H101	9WV1224H1D001	9WV1224P1H001	120 × 120 × 38 mm	No	307
9WV1224P1J601	9WV1224J1002	9WV1224J1001	—	9WV1224P1J601	120 × 120 × 38 mm	No	307
9WV1248P1J001	9WV1248J1002	9WV1248J1001	9WV1248J1D001	9WV1248P1J001	120 × 120 × 38 mm	No	307

Note 1: For compliance with standards, see individual product pages. Please contact your point of sale regarding low-speed sensors.

Note 2: The 🚚 mark indicates Short Lead Time Service applicable models. See p. 654 for details.

Index by Model No./Safety Standards List - ACDC Fans

Models listed in product pages	Option	Frame size	Model	Rated voltage [V]	Rib	Standard (certification status is for the models listed in this catalog, and standards for optional model numbers may differ.)					page
	Pulse sensor					UL (cUL)	CSA (cUL)	TÜV	CE	PSE	
▶ 9AD0901H12	9AD0901H11	92 × 92 × 38 mm	San Ace 92AD	100 to 240	Yes	✓	✓	✓	✓	✓	516
▶ 9AD0901H121	9AD0901H111	92 × 92 × 38 mm	San Ace 92AD	100 to 240	No	✓	✓	✓	✓	✓	516
▶ 9AD0901H1H	9AD0901H11	92 × 92 × 38 mm	San Ace 92AD	100 to 240	Yes	✓	✓	✓	✓	✓	516
▶ 9AD0901H1H1	9AD0901H111	92 × 92 × 38 mm	San Ace 92AD	100 to 240	No	✓	✓	✓	✓	✓	516
▶ 9AD0901M12	9AD0901M11	92 × 92 × 38 mm	San Ace 92AD	100 to 240	Yes	✓	✓	✓	✓	✓	516
▶ 9AD0901M121	9AD0901M111	92 × 92 × 38 mm	San Ace 92AD	100 to 240	No	✓	✓	✓	✓	✓	516
▶ 9AD0901M1H	9AD0901M11	92 × 92 × 38 mm	San Ace 92AD	100 to 240	Yes	✓	✓	✓	✓	✓	516
▶ 9AD0901M1H1	9AD0901M111	92 × 92 × 38 mm	San Ace 92AD	100 to 240	No	✓	✓	✓	✓	✓	516
▶ 9AD1201H12	9AD1201H11	120 × 120 × 38 mm	San Ace 120AD	100 to 240	Yes	✓	✓	✓	✓	✓	519
▶ 9AD1201H121	9AD1201H111	120 × 120 × 38 mm	San Ace 120AD	100 to 240	No	✓	✓	✓	✓	✓	519
▶ 9AD1201H1H	9AD1201H11	120 × 120 × 38 mm	San Ace 120AD	100 to 240	Yes	✓	✓	✓	✓	✓	519
▶ 9AD1201H1H1	9AD1201H111	120 × 120 × 38 mm	San Ace 120AD	100 to 240	No	✓	✓	✓	✓	✓	519
9ADTS11P0F001	—	∅225 × 99 mm	San Ace 225AD	115	—	✓	✓	✓	✓	—	522
9ADTS11P0G001	—	∅225 × 99 mm	San Ace 225AD	115	—	✓	✓	✓	✓	—	522
9ADTS23P0F001	—	∅225 × 99 mm	San Ace 225AD	230	—	✓	✓	✓	✓	—	522
9ADTS23P0G001	—	∅225 × 99 mm	San Ace 225AD	230	—	✓	✓	✓	✓	—	522
9ADW1TS11P0H001	—	∅225 × 99 mm	San Ace 225AD	115	—	✓	✓	✓	✓	—	525
9ADW1TS11P0M001	—	∅225 × 99 mm	San Ace 225AD	115	—	✓	✓	✓	✓	—	525
9ADW1TS23P0H001	—	∅225 × 99 mm	San Ace 225AD	230	—	✓	✓	✓	✓	—	525
9ADW1TS23P0M001	—	∅225 × 99 mm	San Ace 225AD	230	—	✓	✓	✓	✓	—	525
9ADB1TS11P0F001	—	270 × 270 × 119 mm	San Ace 225AD	115	—	✓	✓	✓	✓	—	528
9ADB1TS11P0G001	—	270 × 270 × 119 mm	San Ace 225AD	115	—	✓	✓	✓	✓	—	528
9ADB1TS23P0F001	—	270 × 270 × 119 mm	San Ace 225AD	230	—	✓	✓	✓	✓	—	528
9ADB1TS23P0G001	—	270 × 270 × 119 mm	San Ace 225AD	230	—	✓	✓	✓	✓	—	528
9ADB1W1TS11P0H001	—	270 × 270 × 119 mm	San Ace 225AD	115	—	✓	✓	✓	✓	—	531
9ADB1W1TS11P0M001	—	270 × 270 × 119 mm	San Ace 225AD	115	—	✓	✓	✓	✓	—	531
9ADB1W1TS23P0H001	—	270 × 270 × 119 mm	San Ace 225AD	230	—	✓	✓	✓	✓	—	531
9ADB1W1TS23P0M001	—	270 × 270 × 119 mm	San Ace 225AD	230	—	✓	✓	✓	✓	—	531

Note 1: Please contact your point of sale for pulse sensors and lock sensors.

Note 2: The ▶ mark indicates Short Lead Time Service applicable models. See p. 654 for details.

Index by Model No./Safety Standards List - AC Fans

Models listed in product pages	Frame size	Model	Rated voltage [V]	UL	CSA	TÜV	CE	PSE	Note	page
109-033UL	80×80×42 mm	San Ace 80	115	✓	✓	✓	✓	✓		546
109-040UL	80×80×42 mm	San Ace 80	100	✓	✓	✓	✓	✓		546
109-041UL	80×80×42 mm	San Ace 80	200	✓	✓	✓	✓	✓		546
109-043UL	80×80×42 mm	San Ace 80	115	✓	✓	✓	✓	✓		546
109-044UL	80×80×42 mm	San Ace 80	230	✓	✓	✓	✓	✓		546
109-047UL	80×80×42 mm	San Ace 80	100	✓	✓	✓	✓	✓		546
109-130	60×60×38 mm	San Ace 60	100	✓	—	✓	✓	—		538
109-133	60×60×38 mm	San Ace 60	115	✓	—	✓	✓	—		538
109-150	80×80×38 mm	San Ace 80	100	✓	✓	✓	✓	✓		544
109-151	80×80×38 mm	San Ace 80	200	✓	✓	✓	✓	✓		544
109-153	80×80×38 mm	San Ace 80	115	✓	✓	✓	✓	✓		544
109-154	80×80×38 mm	San Ace 80	230	✓	✓	✓	✓	✓		544
109-180	60×60×28 mm	San Ace 60	100	✓	—	✓	✓	—		536
109-183	60×60×28 mm	San Ace 60	115	✓	—	✓	✓	—		536
109-210	80×80×20 mm	San Ace 80	100	✓	✓	✓	✓	—		540
109-213	80×80×20 mm	San Ace 80	115	✓	✓	✓	✓	—		540
109-311	∅172×51 mm (Round type)	San Ace 172	100	✓	✓	✓	✓	✓		566
109-312	∅172×51 mm (Round type)	San Ace 172	200	✓	✓	✓	✓	✓		566
109-313	∅172×51 mm (Round type)	San Ace 172	230	✓	✓	✓	✓	✓		566
109-314	∅172×51 mm (Round type)	San Ace 172	115	✓	✓	✓	✓	✓		566
109-371	∅172×51 mm (with sensor)	San Ace 172	100	✓	—	✓	✓	✓		566
109-372	∅172×51 mm (with sensor)	San Ace 172	200	✓	—	✓	✓	✓		566
109-373	∅172×51 mm (with sensor)	San Ace 172	230	✓	—	✓	✓	✓		566
109-374	∅172×51 mm (with sensor)	San Ace 172	115	✓	—	✓	✓	✓		566
109-601	160×160×51 mm	San Ace 160	100	✓	✓	✓	✓	✓		561
109-602	160×160×51 mm	San Ace 160	200	✓	✓	✓	✓	✓		561
109-603	160×160×51 mm	San Ace 160	230	✓	✓	✓	✓	✓		561
109-604	160×160×51 mm	San Ace 160	115	✓	✓	✓	✓	✓		561
109-641	160×160×51 mm (with sensor)	San Ace 160	100	✓	—	✓	✓	✓		561
109-642	160×160×51 mm (with sensor)	San Ace 160	200	✓	—	✓	✓	✓		561
109-643	160×160×51 mm (with sensor)	San Ace 160	230	✓	—	✓	✓	✓		561
109-644	160×160×51 mm (with sensor)	San Ace 160	115	✓	—	✓	✓	✓		561
109S005	120×120×38 mm	San Ace 120	100	—	—	—	—	✓		556
109S005UL	120×120×38 mm	San Ace 120	100	✓	✓	✓	✓	✓		556
109S006	120×120×38 mm	San Ace 120	100	—	—	—	—	✓		556
109S006UL	120×120×38 mm	San Ace 120	100/115	✓	✓	✓	✓	✓		556
109S008	120×120×38 mm	San Ace 120	200	—	—	—	—	✓		556
109S008UL	120×120×38 mm	San Ace 120	200	✓	✓	✓	✓	✓		556
109S010	120×120×38 mm	San Ace 120	200	—	—	—	—	✓		556
109S010UL	120×120×38 mm	San Ace 120	200/240	✓	✓	✓	✓	✓		556
109S013	120×120×38 mm	San Ace 120	100	—	—	—	—	✓		556
109S013UL	120×120×38 mm	San Ace 120	100	✓	✓	✓	✓	✓		556
109S024	120×120×38 mm	San Ace 120	120	—	—	—	—	✓		556
109S024UL	120×120×38 mm	San Ace 120	115	✓	✓	✓	✓	✓		556
109S025	120×120×38 mm	San Ace 120	230	—	—	—	—	✓		556
109S025UL	120×120×38 mm	San Ace 120	230	✓	✓	✓	✓	✓		556
109S029UL	120×120×38 mm	San Ace 120	100	✓	✓	✓	✓	✓		556
109S030	80×80×25 mm	San Ace 80	100	✓	✓	✓	✓	✓		542
109S031	80×80×25 mm	San Ace 80	200	✓	✓	✓	✓	✓		542
109S033	80×80×25 mm	San Ace 80	115	✓	✓	✓	✓	✓		542
109S034	80×80×25 mm	San Ace 80	230	✓	✓	✓	✓	✓		542
109S050	80×80×25 mm	San Ace 80	100	✓	✓	✓	✓	✓		542
109S051	80×80×25 mm	San Ace 80	200	✓	✓	✓	✓	✓		542
109S053	80×80×25 mm	San Ace 80	115	✓	✓	✓	✓	✓		542
109S054	80×80×25 mm	San Ace 80	230	✓	✓	✓	✓	✓		542
109S072UL	120×120×38 mm	San Ace 120	230	✓	✓	✓	✓	✓		556
109S074UL	120×120×38 mm	San Ace 120	115	✓	✓	✓	✓	✓		556
109S075UL	120×120×38 mm	San Ace 120	100	✓	✓	✓	✓	✓		556
109S078UL	120×120×38 mm	San Ace 120	200	✓	✓	✓	✓	✓		556
109S081	120×120×25 mm	San Ace 120	100	✓	✓	✓	✓	✓		552
109S082	120×120×25 mm	San Ace 120	200	✓	✓	✓	✓	✓		552
109S083	120×120×25 mm	San Ace 120	115	✓	✓	✓	✓	✓		552
109S084	120×120×25 mm	San Ace 120	115	✓	✓	✓	✓	✓		552
109S085	120×120×25 mm	San Ace 120	100	✓	✓	✓	✓	✓		552

Models listed in product pages	Frame size	Model	Rated voltage [V]	UL	CSA	TÜV	CE	PSE	Note	page
109S086	120 × 120 × 25 mm	San Ace 120	100	✓	✓	✓	✓	✓		552
109S087	120 × 120 × 25 mm	San Ace 120	230	✓	✓	✓	✓	✓		552
109S088	120 × 120 × 25 mm	San Ace 120	200	✓	✓	✓	✓	✓		552
109S089	120 × 120 × 25 mm	San Ace 120	230	✓	✓	✓	✓	✓		552
109S091	92 × 92 × 25 mm	San Ace 92	100	✓	✓	✓	✓	✓		548
109S092	92 × 92 × 25 mm	San Ace 92	200	✓	✓	✓	✓	✓		548
109S093	92 × 92 × 25 mm	San Ace 92	115	✓	✓	✓	✓	✓		548
109S094	92 × 92 × 25 mm	San Ace 92	230	✓	✓	✓	✓	✓		548
109S095	92 × 92 × 25 mm	San Ace 92	100	✓	✓	✓	✓	✓		548
109S096	92 × 92 × 25 mm	San Ace 92	100	✓	✓	✓	✓	✓		548
109S192	92 × 92 × 25 mm	San Ace 92	200	✓	✓	✓	✓	✓		548
109S193	92 × 92 × 25 mm	San Ace 92	115	✓	✓	✓	✓	✓		548
109S194	92 × 92 × 25 mm	San Ace 92	230	✓	✓	✓	✓	✓		548
109S301	∅172 × 150 × 51 mm (Sidecut type)	San Ace 172	100	✓	✓	✓	✓	✓		564
109S302	∅172 × 150 × 51 mm (Sidecut type)	San Ace 172	200	✓	✓	✓	✓	✓		564
109S303	∅172 × 150 × 51 mm (Sidecut type)	San Ace 172	230	✓	✓	✓	✓	✓		564
109S304	∅172 × 150 × 51 mm (Sidecut type)	San Ace 172	115	✓	✓	✓	✓	✓		564
109S405UL	120 × 120 × 38 mm (with sensor)	San Ace 120	100	✓	—	✓	✓	✓		557
109S406UL	120 × 120 × 38 mm (with sensor)	San Ace 120	100	✓	—	✓	✓	✓		557
109S408UL	120 × 120 × 38 mm (with sensor)	San Ace 120	200	✓	—	✓	✓	✓		557
109S424UL	120 × 120 × 38 mm (with sensor)	San Ace 120	115	✓	—	✓	✓	✓		557
109S425UL	120 × 120 × 38 mm (with sensor)	San Ace 120	230	✓	—	✓	✓	✓		557
109S429UL	120 × 120 × 38 mm (with sensor)	San Ace 120	100	✓	—	✓	✓	✓		557
109S472UL	120 × 120 × 38 mm (with sensor)	San Ace 120	230	✓	—	✓	✓	✓		557
109S474UL	120 × 120 × 38 mm (with sensor)	San Ace 120	115	✓	—	✓	✓	✓		557
109S475UL	120 × 120 × 38 mm (with sensor)	San Ace 120	100	✓	—	✓	✓	✓		557
109S478UL	120 × 120 × 38 mm (with sensor)	San Ace 120	200	✓	—	✓	✓	✓		557
109S484	120 × 120 × 25 mm (with sensor)	San Ace 120	115	✓	—	✓	✓	✓		552
109S485	120 × 120 × 25 mm (with sensor)	San Ace 120	100	✓	—	✓	✓	✓		552
109S486	120 × 120 × 25 mm (with sensor)	San Ace 120	100	✓	—	✓	✓	✓		552
109S487	120 × 120 × 25 mm (with sensor)	San Ace 120	230	✓	—	✓	✓	✓		552
109S488	120 × 120 × 25 mm (with sensor)	San Ace 120	200	✓	—	✓	✓	✓		552
109S491	92 × 92 × 25 mm (with sensor)	San Ace 92	100	✓	—	✓	✓	✓		548
109S492	92 × 92 × 25 mm (with sensor)	San Ace 92	200	✓	—	✓	✓	✓		548
109S493	92 × 92 × 25 mm (with sensor)	San Ace 92	115	✓	—	✓	✓	✓		548
109S494	92 × 92 × 25 mm (with sensor)	San Ace 92	230	✓	—	✓	✓	✓		548
109S495	92 × 92 × 25 mm (with sensor)	San Ace 92	100	✓	—	✓	✓	✓		548
109S496	92 × 92 × 25 mm (with sensor)	San Ace 92	100	✓	—	✓	✓	✓		548

Index by Model No. - Options

■ Finger Guards

Model no.	Category	Matching fan size	page
109-019C	Finger Guards	120 mm sq. type	585
109-019E	Finger Guards	120 mm sq. type	585
109-019H	Finger Guards	120 mm sq. type	585
109-019K	Finger Guards	120 mm sq. type	585
109-049C	Finger Guards	80 mm sq. type	584
109-049E	Finger Guards	80 mm sq. type	584
109-049H	Finger Guards	80 mm sq. type	584
109-059	Finger Guards	40 mm sq. type	584
109-059H	Finger Guards	40 mm sq. type	584
109-099C	Finger Guards	92 mm sq. type	584
109-099E	Finger Guards	92 mm sq., ϕ 100 mm type	584
109-099H	Finger Guards	92 mm sq., ϕ 100 mm type	584
109-1050	Finger Guards	36 mm sq. type	584
109-1051	Finger Guards	150 mm sq. type	585
109-1052	Finger Guards	150 mm sq. type	585
109-1065	Finger Guards	38 mm sq. type	584
109-1066	Finger Guards	ϕ 172 mm type	586
109-1068	Finger Guards	ϕ 172 mm type	586
109-1102	Finger Guards	ϕ 200 mm type	587
109-1102H	Finger Guards	ϕ 200 mm type	587
109-1103	Finger Guards	ϕ 200 mm type	587
109-1103H	Finger Guards	ϕ 200 mm type	587
109-1104	Finger Guards	ϕ 150 mm type	585
109-1104H	Finger Guards	ϕ 150 mm type	585
109-1112	Finger Guards	ϕ 133 mm type	585
109-1128	Finger Guards	70 mm sq., ϕ 70 mm type	584
109-1137	Finger Guards	ϕ 225 mm type	587
109-1137H	Finger Guards	ϕ 225 mm type	587
109-1138	Finger Guards	ϕ 221 mm type	587
109-1138H	Finger Guards	ϕ 221 mm type	587
109-1139	Finger Guards	ϕ 136 mm type	585
109-1146	Finger Guards	270 mm sq. type	588
109-1146H	Finger Guards	270 mm sq. type	588
109-1147	Finger Guards	ϕ 92 mm type	584
109-139E	Finger Guards	60 mm sq. type	584
109-139H	Finger Guards	60 mm sq. type	584
109-149	Finger Guards	52 mm sq. type	584
109-149E	Finger Guards	52 mm sq. type	584
109-319E	Finger Guards	ϕ 172 mm type	586
109-319H	Finger Guards	ϕ 172 mm type	586
109-319J	Finger Guards	ϕ 172 mm type	586
109-320	Finger Guards	ϕ 172 mm type	586
109-619E	Finger Guards	160 mm sq. type	585
109-619H	Finger Guards	160 mm sq. type	585
109-620	Finger Guards	160 mm sq. type	585
109-719	Finger Guards	140 mm sq. type	585
109-719H	Finger Guards	140 mm sq. type	585
109-720	Finger Guards	ϕ 200 mm type	587
109-720H	Finger Guards	ϕ 200 mm type	587
109-721	Finger Guards	ϕ 200 mm type	587
109-721H	Finger Guards	ϕ 200 mm type	587
109-722	Finger Guards	127 mm sq., ϕ 175 mm type	585
109-722H	Finger Guards	127 mm sq., ϕ 175 mm type	585
109-723	Finger Guards	127 mm sq. type	585

■ Resin Finger Guards/Resin Filter Kits

Model no.	Category	Matching fan size	page
109-1000F13	Resin Filter Kits	120 mm sq. type	592
109-1000F20	Resin Filter Kits	120 mm sq. type	592
109-1000F30	Resin Filter Kits	120 mm sq. type	592
109-1000F40	Resin Filter Kits	120 mm sq. type	592
109-1001F13	Resin Filter Kits	92 mm sq. type	592
109-1001F20	Resin Filter Kits	92 mm sq. type	592
109-1001F30	Resin Filter Kits	92 mm sq. type	592
109-1001F40	Resin Filter Kits	92 mm sq. type	592
109-1002F13	Resin Filter Kits	80 mm sq. type	592
109-1002F20	Resin Filter Kits	80 mm sq. type	592
109-1002F30	Resin Filter Kits	80 mm sq. type	592
109-1002F40	Resin Filter Kits	80 mm sq. type	592
109-1003F13	Resin Filter Kits	60 mm sq. type	592
109-1003F20	Resin Filter Kits	60 mm sq. type	592
109-1003F30	Resin Filter Kits	60 mm sq. type	592
109-1003F40	Resin Filter Kits	60 mm sq. type	592
109-1000G	Resin Finger Guards	120 mm sq. type	591
109-1001G	Resin Finger Guards	92 mm sq. type	591
109-1002G	Resin Finger Guards	80 mm sq. type	591
109-1003G	Resin Finger Guards	60 mm sq. type	591

■ Replacement filter

Model no.	Category	Matching fan size	page
109-1000M13	Replacement filter	120 mm sq. type	592
109-1000M20	Replacement filter	120 mm sq. type	592
109-1000M30	Replacement filter	120 mm sq. type	592
109-1000M40	Replacement filter	120 mm sq. type	592
109-1001M13	Replacement filter	92 mm sq. type	592
109-1001M20	Replacement filter	92 mm sq. type	592
109-1001M30	Replacement filter	92 mm sq. type	592
109-1001M40	Replacement filter	92 mm sq. type	592
109-1002M13	Replacement filter	80 mm sq. type	592
109-1002M20	Replacement filter	80 mm sq. type	592
109-1002M30	Replacement filter	80 mm sq. type	592
109-1002M40	Replacement filter	80 mm sq. type	592
109-1003M13	Replacement filter	60 mm sq. type	592
109-1003M20	Replacement filter	60 mm sq. type	592
109-1003M30	Replacement filter	60 mm sq. type	592
109-1003M40	Replacement filter	60 mm sq. type	592

■ EMC guards/Inlet nozzle for centrifugal fan and splash proof centrifugal fan

Model no.	Category	Matching fan size	page
109-1036	EMC guards	∅172 mm type	590
109-1037	EMC guards	120 mm sq. type	590
109-1038	EMC guards	80 mm sq. type	590
109-1039	EMC guards	80 mm sq. type	590
109-1040	EMC guards	92 mm sq. type	590
109-1069	Inlet nozzle for centrifugal fan and splash proof centrifugal fan	∅133 mm type	589
109-1069H	Inlet nozzle for centrifugal fan and splash proof centrifugal fan	∅133 mm type	589
109-1073	Inlet nozzle for centrifugal fan and splash proof centrifugal fan	∅175 mm type	589
109-1073H	Inlet nozzle for centrifugal fan and splash proof centrifugal fan	∅175 mm type	589
109-1080	Inlet nozzle for centrifugal fan and splash proof centrifugal fan	∅100 mm type	589
109-1080H	Inlet nozzle for centrifugal fan and splash proof centrifugal fan	∅100 mm type	589
109-1081	Inlet nozzle for centrifugal fan and splash proof centrifugal fan	∅150 mm type	589
109-1081H	Inlet nozzle for centrifugal fan and splash proof centrifugal fan	∅150 mm type	589
109-1106	Inlet nozzle for centrifugal fan and splash proof centrifugal fan	∅70 mm type	589
109-1134	Inlet nozzle for centrifugal fan and splash proof centrifugal fan	∅225 mm type	589
109-1134H	Inlet nozzle for centrifugal fan and splash proof centrifugal fan	∅225 mm type	589
109-1135	Inlet nozzle for centrifugal fan and splash proof centrifugal fan	∅221 mm type	589
109-1135H	Inlet nozzle for centrifugal fan and splash proof centrifugal fan	∅221 mm type	589

■ Filter kits/Screen kits

Model no.	Category	Matching fan size	Note	page
109-018	Filter kits	120 × 120 × 38 mm	Not mountable on AC fans with a sensor or ACDC fans.	593
109-020	Screen kits	120 × 120 × 38 mm		593

■ Plug Cord

Model no.	UL	CSA	PSE	Applicable model	page
489-006-L10			✓	120 × 120 × 38 mm	594
489-006-L21			✓	120 × 120 × 38 mm	594
489-006-L35			✓	120 × 120 × 38 mm	594
489-007-L10	✓	✓		120 × 120 × 38 mm	595
489-007-L21	✓	✓		120 × 120 × 38 mm	595
489-008-L10			✓	80 × 80 × 42 mm	594
489-008-L21			✓	80 × 80 × 42 mm	594
489-008-L35			✓	80 × 80 × 42 mm	594
489-016-L10			✓	120 × 120 × 25 mm 92 × 92 × 25 mm 80 × 80 × 25 mm 80 × 80 × 38 mm	594
489-016-L21			✓	120 × 120 × 25 mm 92 × 92 × 25 mm 80 × 80 × 25 mm 80 × 80 × 38 mm	594
489-037-L10			✓	120 × 120 × 38 mm	594
489-037-L21			✓	120 × 120 × 38 mm	594
489-037-L35			✓	120 × 120 × 38 mm	594
489-047-L10	✓	✓		120 × 120 × 25 mm 92 × 92 × 25 mm 80 × 80 × 25 mm 80 × 80 × 38 mm	595
489-047-L21	✓	✓		120 × 120 × 25 mm 92 × 92 × 25 mm 80 × 80 × 25 mm 80 × 80 × 38 mm	595
489-084-L10	✓	✓		∅172 × 51 mm ∅172 × 150 × 51 mm 160 × 160 × 51 mm	595
489-084-L21	✓	✓		∅172 × 51 mm ∅172 × 150 × 51 mm 160 × 160 × 51 mm	595
489-086-L10	✓	✓		160 × 160 × 51 mm	595
489-086-L21	✓	✓		160 × 160 × 51 mm	595
489-1618-L10			✓	160 × 160 × 51 mm	594
489-1618-L21			✓	160 × 160 × 51 mm	594
489-1618-L28			✓	160 × 160 × 51 mm	594
489-1619-L10			✓	∅172 × 51 mm ∅172 × 150 × 51 mm 160 × 160 × 51 mm	594
489-1619-L21			✓	∅172 × 51 mm ∅172 × 150 × 51 mm 160 × 160 × 51 mm	594
489-1635-L10	✓	✓	✓	ACDC Fan	595
489-1635-L21	✓	✓	✓		595

Typical Connectors for DC Fans page 596

Deleted Models in this Catalog

Following models were deleted in this latest version of catalog. However, these models are not discontinued product. Please contact us for further assistance if necessary.

DC Fan

Size	Model no.	Frame material	Rated voltage [V]	Operating voltage range [V]	Rated current [A]	Rated input [W]	Rated speed [min ⁻¹]	Max. airflow [m ³ /min] [CFM]		Max. static pressure [Pa] [inchH ₂ O]		SPL [dB (A)]	Operating temperature [°C]	Expected life [h]
52×52×15 mm	109P0512A701	Plastics	12	10.2 to 13.8	0.21	2.52	6800	0.375	13.25	69.7	0.28	36	-20 to +70	40000/60°C
52×52×15 mm	109P0512H701	Plastics	12	7 to 13.8	0.1	1.2	4600	0.255	9.0	31.9	0.128	27	-20 to +70	60000/60°C
52×52×15 mm	109P0512M701	Plastics	12	7 to 13.8	0.07	0.84	3700	0.205	7.24	21.4	0.086	22	-20 to +70	60000/60°C
52×52×15 mm	109P0524A701	Plastics	24	14 to 27.6	0.11	2.64	6800	0.375	13.24	69.7	0.28	36	-20 to +60	40000/60°C
52×52×15 mm	109P0524H701	Plastics	24	14 to 27.6	0.05	1.2	4600	0.255	9.0	31.9	0.128	27	-20 to +70	60000/60°C
52×52×15 mm	109P0524M701	Plastics	24	14 to 27.6	0.04	0.96	3700	0.205	7.24	21.4	0.086	22	-20 to +70	60000/60°C
60×60×15 mm	109P0605H701	Plastics	5	4.5 to 5.5	0.26	1.3	4100	0.4	14.1	38.2	0.153	32	-20 to +70	60000/60°C
60×60×15 mm	109P0605M701	Plastics	5	4.5 to 5.5	0.15	0.75	3100	0.3	10.6	22.6	0.091	25	-20 to +70	60000/60°C
60×60×15 mm	109P0612K701	Plastics	12	10.2 to 13.8	0.26	3.12	6500	0.62	21.9	99.3	0.399	45	-20 to +60	40000/60°C
60×60×15 mm	109P0612S701	Plastics	12	10.2 to 13.8	0.15	1.8	5000	0.48	17	58.8	0.236	36	-20 to +70	40000/60°C
60×60×15 mm	109P0612H701	Plastics	12	7 to 13.8	0.09	1.08	4100	0.4	14.1	38.2	0.153	32	-20 to +70	60000/60°C
60×60×15 mm	109P0612M701	Plastics	12	10.2 to 13.8	0.07	0.84	3100	0.3	10.6	22.6	0.091	25	-20 to +70	60000/60°C
60×60×15 mm	109P0612B701	Plastics	12	10.2 to 13.8	0.05	0.6	2200	0.21	7.42	11.7	0.047	21	-20 to +70	60000/60°C
60×60×15 mm	109P0624J701	Plastics	24	14 to 27.6	0.14	3.36	6200	0.61	21.5	86.5	0.347	44	-20 to +60	40000/60°C
60×60×15 mm	109P0624S701	Plastics	24	14 to 27.6	0.08	1.92	5000	0.48	16.9	58.8	0.236	36	-20 to +70	40000/60°C
60×60×15 mm	109P0624H701	Plastics	24	14 to 27.6	0.06	1.44	4100	0.4	14.1	38.2	0.153	32	-20 to +70	60000/60°C
60×60×15 mm	109P0624M701	Plastics	24	20.4 to 27.6	0.04	0.96	3100	0.3	10.6	22.6	0.091	25	-20 to +70	60000/60°C
60×60×20 mm	109P0612W601	Plastics	12	6 to 16	0.13	1.56	4200	0.42	14.8	31.8	0.128	31	-20 to +70	60000/60°C
60×60×20 mm	109P0612H601	Plastics	12	10.2 to 13.8	0.13	1.56	4200	0.42	14.8	31.8	0.128	31	-20 to +70	60000/60°C
60×60×20 mm	109P0612M601	Plastics	12	10.2 to 13.8	0.09	1.08	3200	0.3	10.6	18.8	0.076	25	-20 to +70	60000/60°C
60×60×20 mm	109P0624W601	Plastics	24	12 to 30	0.07	1.68	4200	0.42	14.8	31.8	0.128	31	-20 to +70	60000/60°C
60×60×20 mm	109P0624H601	Plastics	24	20.4 to 27.6	0.07	1.68	4200	0.42	14.8	31.8	0.128	31	-20 to +70	60000/60°C
60×60×20 mm	109P0624M601	Plastics	24	20.4 to 27.6	0.05	1.2	3200	0.3	10.6	18.8	0.076	25	-20 to +70	60000/60°C
60×60×20 mm	109P0648H601	Plastics	48	43 to 53	0.07	3.36	5600	0.55	19.4	52.9	0.212	41	-20 to +70	40000/60°C
60×60×38 mm	9G0612G101	Plastics	12	7.0 to 13.8	1.54	18.5	11800	1.84	65	435	1.747	58	-20 to +70	40000/60°C
60×60×38 mm	9G0612S101	Plastics	12	7.0 to 13.8	1.36	16.3	10800	1.7	60	370	1.486	56	-20 to +70	40000/60°C
60×60×38 mm	9G0624G101	Plastics	24	14.0 to 27.6	0.85	20.4	11800	1.84	65	435	1.747	58	-20 to +70	40000/60°C
60×60×38 mm	9G0624S101	Plastics	24	14.0 to 27.6	0.7	16.8	10800	1.7	60	370	1.486	56	-20 to +70	40000/60°C
60×60×38 mm	9G0624H101	Plastics	24	14.0 to 27.6	0.57	13.68	9800	1.54	54.4	304.6	1.223	54	-20 to +70	40000/60°C
60×60×38 mm	9G0648G101	Plastics	48	28 to 55.2	0.35	16.8	11800	1.84	65	435	1.747	58	-20 to +70	40000/60°C
60×60×38 mm	9G0648S101	Plastics	48	28 to 55.2	0.29	13.9	10800	1.7	60	370	1.486	56	-20 to +70	40000/60°C
∅200×70 mm	109E2024S001	Aluminum	24	21.6 to 26.4	1.9	45.6	3200	10.45	369	287.1	1.153	57	-10 to +70	40000
∅200×70 mm	109E2024H001	Aluminum	24	20.4 to 27.6	1.0	24	2600	8.2	289.5	192	0.771	51	-10 to +70	40000
∅200×70 mm	109E2024AS001	Aluminum	24	21.6 to 26.4	1.9	45.6	3200	10.45	369	287.1	1.153	57	-10 to +70	40000
∅200×70 mm	109E2024AS001	Aluminum	24	21.6 to 26.4	1.45	34.8	2800	9	317.8	215.6	0.865	54	-10 to +70	40000
∅200×70 mm	109E2024MH001	Aluminum	24	20.4 to 27.6	1.0	24	2600	8.2	289.5	192	0.771	51	-10 to +70	40000
∅200×70 mm	109E2024MH001	Aluminum	24	20.4 to 27.6	0.63	15.12	2100	6.7	236.6	115.4	0.463	45	-10 to +70	40000

Size	Model no.	Frame material	Rated voltage [V]	Operating voltage range [V]	PWM duty cycle* [%]	Rated current [A]	Rated input [W]	Rated speed [min ⁻¹]	Max. airflow [m ³ /min] [CFM]		Max. static pressure [Pa] [inchH ₂ O]		SPL [dB (A)]	Operating temperature [°C]	Expected life [h]
60×60×38 mm	9GV0612P1H03	Plastics	12	8.0 to 13.8	100	2.0	24.0	14500	2.15	76	617	2.48	63	-20 to +70	40000/60°C
					0	0.1	1.2	2700	0.4	14	21	0.09	22		
60×60×38 mm	9GV0612P1M03	Plastics	12	8.0 to 13.8	100	1.5	18.0	13000	1.93	68	496	1.99	60	-20 to +70	40000/60°C
					0	0.08	1.0	2500	0.38	13	18	0.07	19		
60×60×38 mm	9GV0612P1L01	Plastics	12	8.0 to 13.8	100	0.7	8.4	10000	1.49	52.6	293	1.17	52	-20 to +70	40000/60°C
60×60×38 mm	9GV0624P1M03	Plastics	24	20.4 to 27.6	100	0.73	17.52	13000	1.93	68.0	496	1.99	60	-20 to +70	40000/60°C

* PWM frequency: 25 kHz

Counter Rotating Fan

Size	Model no.	Frame material	Rated voltage [V]	Operating voltage range [V]	Rated current [A]	Rated input [W]	Rated speed [min ⁻¹] Inlet Outlet	Max. airflow [m ³ /min] [CFM]	Max. static pressure [Pa] [inchH ₂ O]	SPL [dB (A)]	Operating temperature [°C]	Expected life [h]
40 × 40 × 56 mm	9CRA0412K501	Plastic	12	10.8 to 12.6	1.8	21.6	17000 13000	0.95 33.5	650 2.61	65	-20 to +60	40000
80 × 80 × 80 mm	9CR0812S801	Plastic	12	10.8 to 13.2	5.5	66.0	8000 5300	4.53 160	520 2.09	71	-10 to +60	40000
80 × 80 × 80 mm	9CR0812H801	Plastic	12	10.8 to 13.2	3.6	43.2	7000 4600	3.97 140	400 1.61	68	-10 to +60	40000

Size	Model no.	Frame material	Rated voltage [V]	PWM frequency [kHz]	Rated current [A]	Rated speed [min ⁻¹]		Max. airflow [m ³ /min] [CFM]	Max. static pressure [Pa] [inchH ₂ O]	SPL [dB (A)]	Expected Life [h]
						Duty cycle 0%	Duty cycle 100%				
60 × 60 × 76 mm	9CR0612P0S03	Plastic	12	25.0	3.2	Inlet: 1300 Outlet: 800	Inlet: 11500 Outlet: 7000	2.26 79.8	550 2.21	66	40000
	9CR0612P0H03	Plastic	12	25.0	2.7	Inlet: 1200 Outlet: 800	Inlet: 10300 Outlet: 6500	1.98 69.91	450 1.81	64	40000
80 × 80 × 80 mm	9CR0848P8S03	Plastic	48	25.0	1.29	Inlet: 2000 Outlet: 1300	Inlet: 8000 Outlet: 5300	4.53 159.95	520 2.09	71	40000

Size	Model no.	Frame material	Rated voltage [V]	Operating voltage range [V]	PWM duty cycle* [%]	Rated current [A]	Rated input [W]	Rated speed [min ⁻¹]		Max. airflow [m ³ /min] [CFM]	Max. static pressure [Pa] [inchH ₂ O]	SPL [dB (A)]	Operating temperature [°C]	Expected life [h]
								Inlet	Outlet					
40 × 40 × 56 mm	9CRB0412P5S201	Plastic	12	10.8 to 13.2	100	1.4	16.8	22000	19700	0.9 31.8	1045 4.197	68	-20 to +70	40000
								0	0.09	1.08	3800	3500	0.15 5.3	31 0.124
40 × 40 × 56 mm	9CRB0412P5K001	Plastic	12	10.8 to 13.2	100	0.88	10.56	19000	17000	0.76 26.83	730 2.93	62	-20 to +70	40000
								0	0.11	1.32	5700	5100	0.21 7.41	67 0.26
40 × 40 × 56 mm	9CRB0412P5J201	Plastic	12	10.8 to 13.2	100	0.72	8.64	17300	16000	0.71 25.1	650 2.61	61	-20 to +70	40000
								0	0.07	0.84	3450	3200	0.13 4.59	26 0.1

* PWM frequency: 25 kHz

Splash Proof Fan

Size	Model no.	Frame material	Rated voltage [V]	Operating voltage range [V]	Rated current [A]	Rated input [W]	Rated speed [min ⁻¹]	Max. airflow [m ³ /min] [CFM]	Max. static pressure [Pa] [inchH ₂ O]	SPL [dB (A)]	Operating temperature [°C]	Expected life [h]
80 × 80 × 25 mm	9WS0812H401	Plastics	12	10.2 to 13.8	0.16	1.92	3100	0.94 33.2	45.1 0.181	32	-20 to +70	40000/60°C
80 × 80 × 25 mm	9WS0812F401	Plastics	12	10.2 to 13.8	0.13	1.56	2700	0.83 29.3	34.3 0.138	28	-20 to +70	40000/60°C
80 × 80 × 25 mm	9WS0812M401	Plastics	12	10.2 to 13.8	0.1	1.2	2200	0.65 23.0	23.5 0.094	23	-20 to +70	40000/60°C
80 × 80 × 25 mm	9WS0824H401	Plastics	24	20.4 to 27.6	0.09	2.16	3100	0.94 33.2	45.1 0.181	32	-20 to +70	40000/60°C
80 × 80 × 25 mm	9WS0824F401	Plastics	24	20.4 to 27.6	0.07	1.68	2700	0.83 29.3	34.3 0.138	28	-20 to +70	40000/60°C
80 × 80 × 25 mm	9WS0824M401	Plastics	24	20.4 to 27.6	0.05	1.2	2200	0.65 23.0	23.5 0.094	23	-20 to +70	40000/60°C
92 × 92 × 25 mm	9WS0912H401	Plastics	12	10.2 to 13.8	0.17	2.04	2850	1.38 48.7	45.1 0.181	33	-20 to +70	40000/60°C
92 × 92 × 25 mm	9WS0912F401	Plastics	12	10.2 to 13.8	0.13	1.56	2450	1.18 41.7	32.3 0.13	30	-20 to +70	40000/60°C
92 × 92 × 25 mm	9WS0912M401	Plastics	12	10.2 to 13.8	0.1	1.2	2100	1.01 35.7	23.5 0.094	27	-20 to +70	40000/60°C
92 × 92 × 25 mm	9WS0912L401	Plastics	12	10.2 to 13.8	0.06	0.72	1700	0.8 28.2	16.7 0.067	23	-20 to +70	40000/60°C
92 × 92 × 25 mm	9WS0924H401	Plastics	24	20.4 to 27.6	0.1	2.4	2850	1.38 48.7	45.1 0.181	33	-20 to +70	40000/60°C
92 × 92 × 25 mm	9WS0924F401	Plastics	24	20.4 to 27.6	0.07	1.68	2450	1.18 41.7	32.3 0.13	30	-20 to +70	40000/60°C
92 × 92 × 25 mm	9WS0924M401	Plastics	24	20.4 to 27.6	0.06	1.44	2100	1.01 35.7	23.5 0.094	27	-20 to +70	40000/60°C
92 × 92 × 25 mm	9WS0924L401	Plastics	24	20.4 to 27.6	0.05	1.2	1700	0.8 28.2	16.7 0.067	23	-20 to +70	40000/60°C

Long Life Fan

Size	Model no.	Frame material	Rated voltage [V]	Operating voltage range [V]	Rated current [A]	Rated input [W]	Rated speed [min ⁻¹]	Max. airflow [m ³ /min] [CFM]	Max. static pressure [Pa] [inchH ₂ O]	SPL [dB (A)]	Operating temperature [°C]	Expected life [h]
60 × 60 × 25 mm	109L0612G401	Aluminum	12	10.2 to 13.8	0.24	2.88	5600	0.78 27.5	87.3 0.35	39	-20 to +70	100000
60 × 60 × 25 mm	109L0612S401	Aluminum	12	10.2 to 13.8	0.17	2.04	4600	0.65 23.0	56.8 0.228	33	-20 to +70	100000
60 × 60 × 25 mm	109L0612H401	Aluminum	12	10.2 to 13.8	0.11	1.32	3800	0.53 18.7	40.2 0.161	28	-20 to +70	100000
60 × 60 × 25 mm	109L0612F401	Aluminum	12	10.2 to 13.8	0.09	1.08	3200	0.44 15.5	29.4 0.118	24	-20 to +70	100000
60 × 60 × 25 mm	109L0612M401	Aluminum	12	10.2 to 13.8	0.06	0.72	2600	0.36 12.7	19.6 0.079	20	-20 to +70	100000
60 × 60 × 25 mm	109L0624D401	Aluminum	24	20.4 to 27.6	0.12	2.88	5150	0.72 25.4	73.8 0.296	37	-20 to +70	100000
60 × 60 × 25 mm	109L0624S401	Aluminum	24	20.4 to 27.6	0.08	1.92	4600	0.65 23.0	56.8 0.23	33	-20 to +70	100000
60 × 60 × 25 mm	109L0624H401	Aluminum	24	20.4 to 27.6	0.06	1.44	3800	0.53 18.7	40.2 0.161	28	-20 to +70	100000
60 × 60 × 25 mm	109L0624F401	Aluminum	24	20.4 to 27.6	0.05	1.2	3200	0.44 15.5	29.4 0.118	24	-20 to +70	100000
60 × 60 × 25 mm	109L0624M401	Aluminum	24	20.4 to 27.6	0.04	0.96	2600	0.36 12.7	19.6 0.079	20	-20 to +70	100000
60 × 60 × 25 mm	109L0648G401	Aluminum	48	40.8 to 55.2	0.07	3.36	5600	0.78 27.5	87.3 0.35	39	-20 to +60	80000
60 × 60 × 25 mm	109L0648H401	Aluminum	48	40 to 53	0.04	1.92	3800	0.53 18.7	40.2 0.161	28	-20 to +70	100000

Blower

Size	Model no.	Frame material	Rated voltage [V]	Operating voltage range [V]	Rated current [A]	Rated input [W]	Rated speed [min ⁻¹]	Max. airflow [m ³ /min] [CFM]	Max. static pressure [Pa] [inchH ₂ O]	SPL [dB (A)]	Operating temperature [°C]	Expected life [h]
120 × 32 mm	109BF12HC2	Plastic	12	10.2 to 13.8	0.6	7.2	2400	0.78 27.5	175.4 0.704	52	-20 to +60	40000
120 × 32 mm	109BF12MC2	Plastic	12	10.2 to 13.8	0.32	3.84	1900	0.61 21.5	109.8 0.441	44	-20 to +60	40000
120 × 32 mm	109BF24HC2	Plastic	24	20.4 to 27.6	0.3	7.2	2400	0.78 27.5	175.4 0.704	52	-20 to +60	40000
120 × 32 mm	109BF24MC2	Plastic	24	20.4 to 27.6	0.16	3.84	1900	0.61 21.5	109.8 0.441	44	-20 to +60	40000

Note: Storage temperature is -30 to +70°C.