

# SCM7B39



## Isolated Process Current Output Modules

### Description

SCM7B39 process current modules accept high-level signals from the process control system and provide either 0 to 20mA or 4 to 20mA current to the field (Figure 1).

These modules incorporate a five-pole filtering approach to maximize both time and frequency response by taking advantage of both Thomson (Bessel) and Butterworth characteristics. One pole of the filter is on the process control system side of the isolation barrier, and the other four poles are on the field side.

After the initial process control system side filtering, the signal is chopped by a proprietary chopper circuit and transferred across the transformer isolation barrier, suppressing transmission of common mode spikes and surges. The signal is then reconstructed, filtered, and converted to a process current for output to the field.

Modules accept a wide 18 - 35VDC power supply range (+24VDC nominal). Their compact packages (2.13"x1.705"x0.605" max) save space and are ideal for high channel density applications. They are designed for easy DIN rail mounting using any of the -DIN backpanels.

### Features

- Accepts High-Level Voltage Input
- Provides 4-20mA or 0-20mA Current Output
- 1500Vrms Transformer Isolation
- Accuracy,  $\pm 0.03\%$  of Span Typical,  $\pm 0.1\%$  Max
- ANSI/IEEE C37.90.1 Transient Protection
- Output Protected to 120Vrms Continuous
- Noise,  $46\mu\text{A}_{p-p}$  (5MHz),  $4\mu\text{Arms}$  (100kHz)
- 110dB CMRR
- Easy DIN Rail Mounting
- CSA C/US Certified
- CE and ATEX Compliant

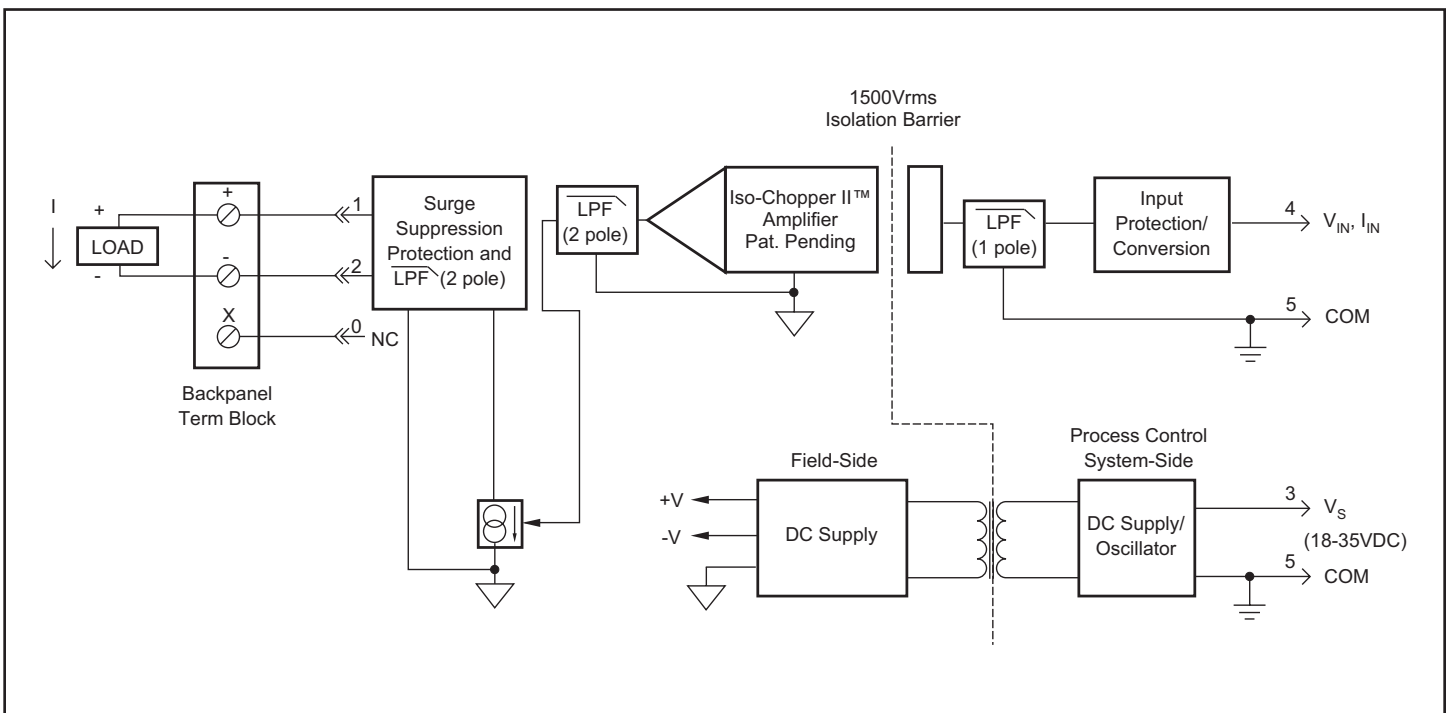

Figure 1: SCM7B39 Block Diagram

**Specifications** Typical\* at 25°C and +24VDC

Module	SCM7B39-01,-02,-03	SCM7B39-04
Output		
Signal Range <sup>(1)</sup>	4-20mA, 0-20mA	4-20mA
Effective Available Power <sup>(1)</sup>	320mW	*
Protection		
Continuous	120Vrms max	*
Transient	ANSI/IEEE C37.90.1	*
Current Limit	32mA	*
Input		
Signal Range	1 to +5V, 0 to +10V	4-20mA
Bias Current	±1nA	N/A
Resistance		
Normal	10MΩ	270Ω
Power Off	30kΩ min	>20kΩ
Overload	30kΩ min	N/A
Protection	±35Vpeak (no damage)	±7.5Vpeak
Compliance	N/A	35VDC max
CMV (Input-to-Output)		
Continuous	1500Vrms	*
Transient	ANSI/IEEE C37.90.1	*
CMRR (50 or 60Hz)	110dB	*
Accuracy <sup>(2)</sup>	±0.03% Span typical, ±0.1% Span max	*
Linearity <sup>(3)</sup>	±0.01% Span typical, ±0.02% Span max	*
Stability (-40°C to +85°C)		
Gain	±25ppm/°C	±50ppm/°C
Output Offset	±0.0035% Span/°C	±0.0045% Span/°C
Noise		
Peak at 5MHz B/W	46μA	*
RMS at 10Hz to 100kHz B/W	4μA	*
Peak at 0.1Hz to 10Hz B/W	42nA	*
Open Output Loop Detection		
Response	N/A	Input Resistance > 20kΩ
Detection Time	N/A	5ms
Frequency and Time Response		
Bandwidth, -3dB	100Hz	*
NMR (-3dB at 100Hz)	80dB per Decade above 100Hz	*
Step Response, 90% Span	5ms	*
Supply Voltage	18 to 35VDC	*
Current <sup>(1)</sup>	56mA	*
Sensitivity	±0.0003% % <sub>s</sub>	*
Mechanical Dimensions (h)(w)(d)	2.13" x 1.705" x 0.605" max (54.1mm x 43.3mm x 15.4mm max)	*
Environmental		
Operating Temperature Range	-40°C to +85°C	*
Storage Temperature Range	-40°C to +85°C	*
Relative Humidity	0 to 95% Noncondensing	*
Emissions EN61000-6-4	ISM, Group 1	*
Radiated, Conducted	Class A	*
Immunity EN61000-6-2	ISM, Group 1	*
RF	Performance A ±0.5% Span Error	*
ESD, EFT	Performance B	*

## NOTES:

\*Contact factory or your local Dataforth sales office for maximum values.

\* Same specification as SCM7B39-01, -02, -03.

 (1) Output Range and Supply Current specifications are based on maximum output load resistance. Maximum output load resistance is calculated by  $P_E / I_{OUT}^2$  where  $P_E$  is the Output Effective Available Power that guarantees output range, accuracy, and linearity specifications. Output effective available power is independent of supply voltage.

(2) Accuracy includes the effects of repeatability, hysteresis, and linearity.

(3) Linearity is calculated using the best-fit straight line method.

**Ordering Information**

Model	Input Range	Output Range
SCM7B39-01	+1 to +5V	4 to 20mA
SCM7B39-02	0 to +10V	0 to 20mA
SCM7B39-03	0 to +10V	4 to 20mA
SCM7B39-04	4 to 20mA	4 to 20mA