

EtherCAT[®]



ECAT-2511-A/ECAT-2511-B

EtherCAT to Single-mode Fiber Converter

Features

- Powerful MCU handles efficient network traffic
- Distance between Stations up to 25 km (100BASE-FX)
- 50% Cost Saving for Fiber Optic Infrastructures
- EtherCAT conformance test tool verified
- ESD Protection 4 KV Contact for each port



Introduction

The ECAT-2511-A and ECAT-2511-B are EtherCAT to single-mode fiber optic converter. They are designed not only to convert EtherCAT signals to optical signals on a fiber optic cable, to reshape the EtherCAT signal to compensate for distortion, but to isolate the bus error due to the wire short or disturbance. With the advantage of fiber optic, the ECAT-2511-A and ECAT-2511-B enable secure data transmission via fiber optic transmission, and helps the EtherCAT network to prevent the noise from EMS/RFI interference.

50% Cost Saving for Fiber Optic Infrastructures:

With a pair of ECAT-2511 series products (ECAT-2511-A and ECAT-2511-B), you can double the utilization of your existing, costly fiber optic cable, and save 50% of the cost of a newly installed fiber optic application.

* EtherCAT[®] is registered trademark and patented technology, licensed by Beckhoff Automation GmbH, Germany.

Hardware Specifications

Model	ECAT-2511-A	ECAT-2511-B
Network Interface		
Protocol	EtherCAT	
RJ-45 Port	RJ-45 x 1 Distance between Stations: Max. 100 m (100BASE-TX) Data Transfer Medium: Ethernet/EtherCAT Cable (Min. CAT 5e)	
Communication Interface		
Fiber Port	Single-Mode; SC connector x 1	Single-Mode; SC connector x 1
Wavelength	TX: 1310, RX: 1550 nm	TX: 1550, RX: 1310
Distance between Stations	25 km (9/125 μm recommended)	
Power		
Input Voltage Range	+12 ~ +48 VDC	
Power Consumption	0.1 A @ 24 VDC	
Protection	Power reverse polarity protection	
Connector	3-Pin Removable Terminal Block (5.08 mm)	
Mechanical		
Dimensions (W x L x H)	33 mm x 127 mm x 100 mm	
Installation	DIN-Rail Mounting	
Casing	Plastic	
Environment		
Operating Temperature	-25 ~ +75°C	
Storage Temperature	-30 ~ +80°C	
Relative Humidity	10 ~ 90% RH, Non-condensing	

Applications

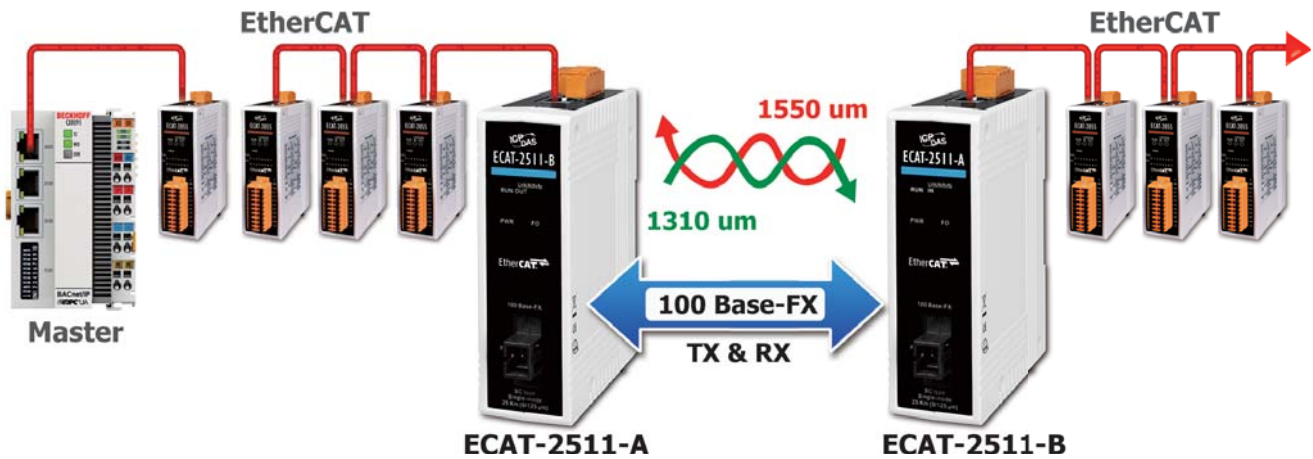

Dimensions (Units: mm)

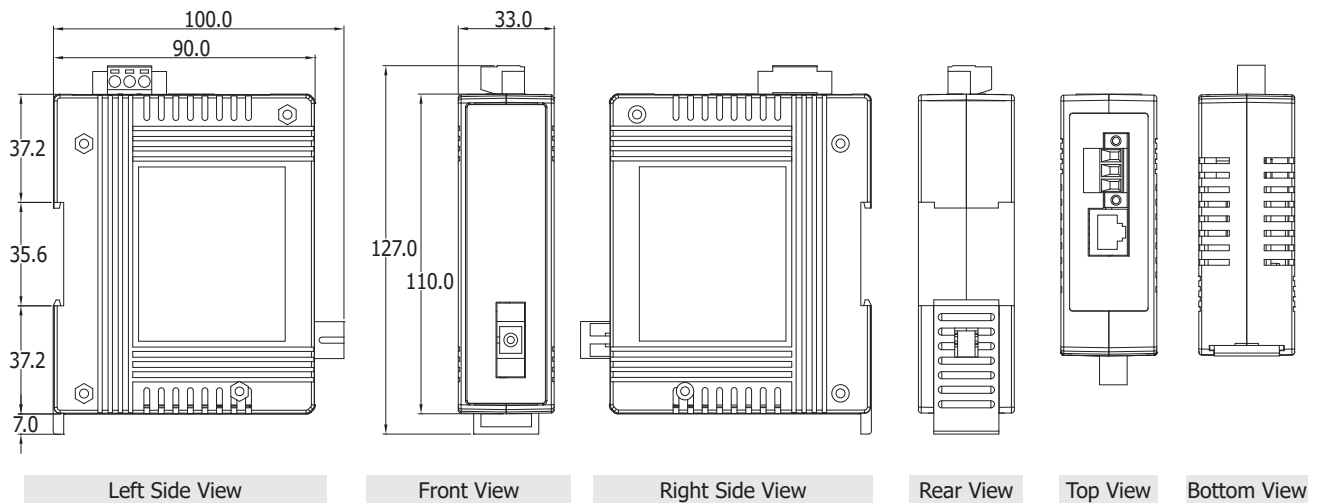

Ordering Information

ECAT-2511-A CR	EtherCAT Single-Strand Media Converter, TX 1310 nm, RX 1550 nm, SC (RoHS)
ECAT-2511-B CR	EtherCAT Single-Strand Media Converter, TX 1550 nm, RX 1310 nm, SC (RoHS)

Important Note: You must purchase both ECAT-2511-A and ECAT-2511-B since these products work as a pair.