



Midas Touch

magic embedded

16 x 16 Thermopile Array Module

PRODUCTION SPECIFICATIONS



Model No. : MTP-16PV



Revision History

Date	Rev.	Contents
2019/04/29	V1.0	First release
2020/04/27	V2.0	Add Thermopile array application to measure human body temperature characteristics and update verify the value



16x16 Thermopile Array MTP-16PV

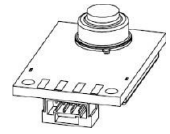

The MTP-16PV series is a 16x16 thermopile array module having a digital output through I2C interface for ease of infrared image processing. The application of MTP-16PV series includes occupancy sensing, gesture control, home security and smart appliance.

The MTP-16PV series is ideal for customers who require their products that can meet time to market with a moderate startup cost.

Features and Benefit

- ★ Factory pre-calibrated
- ★ Low cost and small footprint
- ★ Integrated with infrared optics
- ★ Output reading in °C unit directly

Application Examples

- ★ Alert Body temperature measurement
- ★ White goods
- ★ Energy management
- ★ Intrusion detection

Functional Block Diagram

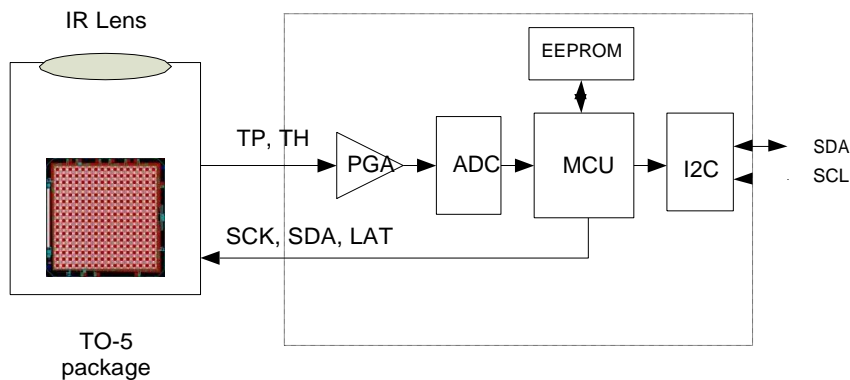

**Absolute Maximum Ratings**

Parameter	Symbol	Min	Typ	Max	Unit	Remarks / Conditions
Storage temperature	T _{Storage}	-40		100	°C	
Power supply	V _{Max}			6.5	V	
I/O pin	V _{SCL} V _{SDA}	-0.3		6.5	V	
ESD (Air Mode)	ESD _H			12	kV	IEC6100-4-2
ESD (Contact Mode)	ESD _M			8	V	IEC6100-4-2

Electrical and Mechanical Characteristic

Parameter	Symbol	Min	Typ	Max	Unit	Remarks / Conditions
Operating Conditions						
Operating voltage	V _D	4.5	5	5.5	V	
Operating current	I _D	-	8.0	-	mA	V _{DD} = 5.0 V, with I2C communication.
Data Communication						
Electrical interface			I2C			
Interface speed			100		KHz	
Slave address			68		hex	7 bits addressing
Physical Interface						
Physical connection interface			SM04B-GHS-TB equivalent			

Thermopile Array Characteristic

Parameter	Symbol	Min	Typ	Max	Unit	Remarks / Conditions
Effective number of pixels			256		pixels	16 x 16 = 256 pixels
NETD			0.4		°C	@0.5fps (-A125 model)
Frame rate			0.5	4	fps	
Field of view	FOV _X FOV _Y		72 72		degrees	

Thermometer Sensing Characteristics

Parameter	Symbol	Min	Typ	Max	Unit	Remarks / Conditions
Ambient Temperature Reading Characteristics						
Temperature range	T _{Amb_rge}	-20		85	°C	
Resolution of reading	T _{Amb_res}		0.05		°C	T _{amb} =25°C
Object Temperature Reading Characteristics						
Temperature range	T _{Obj_rge}	-15		110	°C	
Resolution of reading	T _{Obj_res}		0.05		°C	T _{obj} =25°C
Temperature Calibrated Range						
Object temperature accuracy*1	T _{Acc}	--	±2		°C	T _{amb} =25°C, T _{obj} =80°C Distance to blackbody: 20cm Emissivity: 95%



Thermopile array application to measure human body temperature characteristics

Parameter	Symbol	Min	Typ	Max	Unit	Remarks / Conditions
Ambient Temperature Reading Characteristics						
Temperature range	T _{Amb_rge}	10		70	°C	
Resolution of reading	T _{Amb_res}		0.05		°C	T _{amb} =25°C
Object Temperature Calibrated Range						
Object temperature accuracy*1	T _{Acc}	--	±0.3	±0.4	°C	T _{amb} =28°C, T _a =28.5°C, T _{obj} =35~38°C Distance to blackbody: 50cm Humidity: 58%
Frame rate				980	ms	

Note

- * 1: It is applicable to the sensor area of the center max pixels.
- * 2: Recommended maximum use distance 50cm.

Mechanic Drawing and Pin Assignment

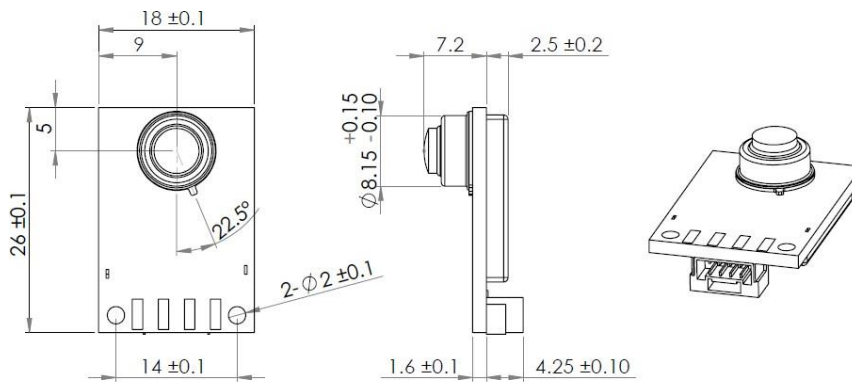

SENSOR PAD - 4PIN
1.2 x 3.5 Pitch 3mm

unit : mm

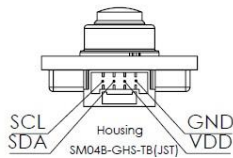



Ordering Information

OTPA model number example

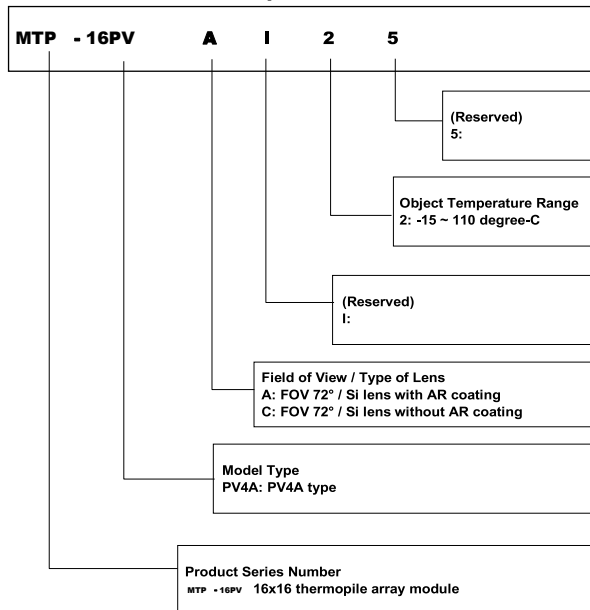

Connector Specification

JST connector / 1.25mm pitch (P/N. SM04B-GHS-TB)

Shrouded header

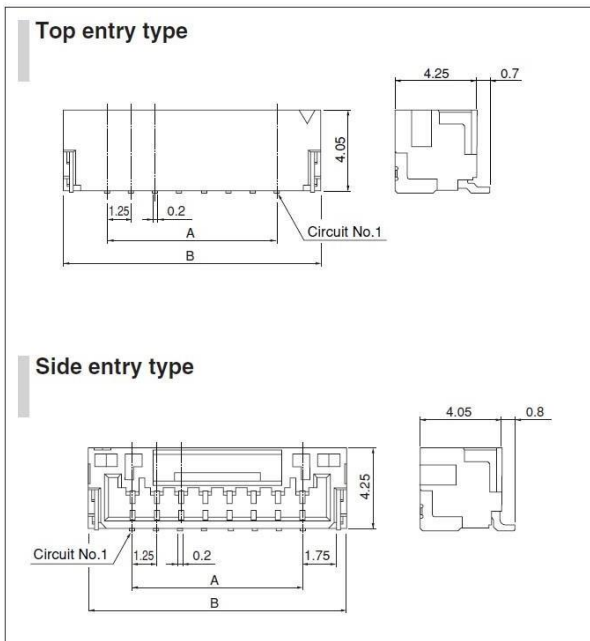

Circuits	Model No.		Dimensions (mm)		Q'ty / reel
	Top entry type	Side entry type	A	B	
2	BM02B-GHS-TBT	SM02B-GHS-TB	1.25	5.75	2,500
3	BM03B-GHS-TBT	SM03B-GHS-TB	2.50	7.00	2,500
4	BM04B-GHS-TBT	SM04B-GHS-TB	3.75	8.25	2,500
5	BM05B-GHS-TBT	SM05B-GHS-TB	5.00	9.50	2,500
6	BM06B-GHS-TBT	SM06B-GHS-TB	6.25	10.75	2,500
7	BM07B-GHS-TBT	SM07B-GHS-TB	7.50	12.00	2,500
8	BM08B-GHS-TBT	SM08B-GHS-TB	8.75	13.25	2,500
9	BM09B-GHS-TBT	SM09B-GHS-TB	10.00	14.50	2,500
10	BM10B-GHS-TBT	SM10B-GHS-TB	11.25	15.75	2,500
11	BM11B-GHS-TBT	SM11B-GHS-TB	12.50	17.00	2,500
12	BM12B-GHS-TBT	SM12B-GHS-TB	13.75	18.25	2,500
13	BM13B-GHS-TBT	SM13B-GHS-TB	15.00	19.50	2,500
14	BM14B-GHS-TBT	SM14B-GHS-TB	16.25	20.75	2,500
15	BM15B-GHS-TBT	SM15B-GHS-TB	17.50	22.00	2,500

Material and Finish

Contact: Phosphor bronze, copper-undercoated, tin-plated (reflow treatment)
Housing: PA9T, UL94V-0, natural (ivory)
Solder tab: Brass, copper-undercoated, tin-plated

RoHS compliance This product displays (LF)(SN) on a label.
Note: Contact JST for gold-plated products.

<For reference> As the color identification, the following alphabet shall be put in the underlined part.
For availability, delivery and minimum order quantity, contact JST.

ex. **BM04B-GHS-TBT**
S...natural (ivory) LE...light blue TR...tomato red K...black
E...blue O...orange L...lemon yellow MG...moss green



Data communication protocol for MTP-16PV series

This application note is applicable to MTP-16PV series of thermopile array module. The MTP-16PV series are 16x16 thermal image sensors, one of which has 256 pixels of sensing elements. Currently the member of MTP-16PV includes MTP-16PV-AI15, MTP-16PV-AI25 and MTP-16PV. To simplified further discussion on the following sections, we use MTP-16PV to represent any member of MTP-16PV series in this application note.

MTP-16PV provides I2C data communication interface and plays a slave role on communicating with an outside controller. The Figure 1 shows an example of typical hardware connection to outside controller.

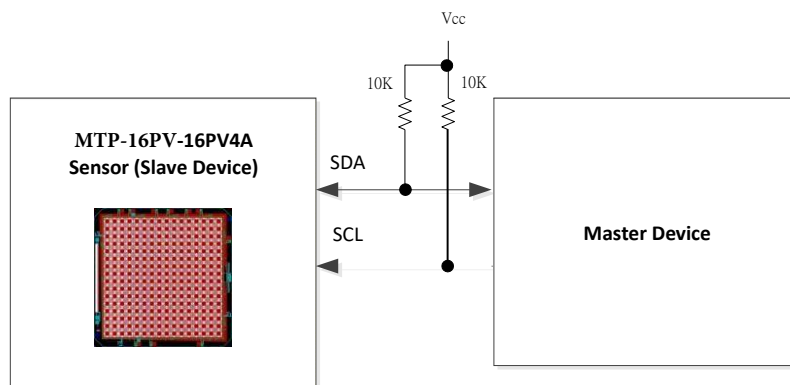

Figure 1. Data communication with I2C interface

1. I2C interface parameters

- I2C address: 68H (slave, 7-bits addressing)
- Data rate: 100 KHz (max.)

2. Command format (master to slave)

There are two types of commands, which functions are described as follows:

- Frame-rate-setting command
- Readout command

2.1 Frame-rate-setting command

The frame-rate-setting command consists of four data bytes, which are denoted as “ADR”, “CMD”, CFG1”, and “CFG2” in sequence. The definition of each parameter is described on Table 1.

Table 1. Contents of frame-rate-setting command

Byte sequence	Syntax	Value	Description
Byte 1	ADR	D0H	Write data to I2C address 68H
Byte 2	CMD	30H	Frame-rate-setting command
Byte 3	CFG1	xxH	Bit[7:4] (Reserved) Bit[3:0] frame rate setting <ul style="list-style-type: none">- 0100: 250ms (4 fps)- 0101: 500ms (2 fps)- 0110: 1 sec (1 fps) [default]- 0111: 2 sec (0.5 fps)



			- Others: reserved
Byte 4	CFG2	xxH	Bit[7:0] (Reserved)

2.2 Readout command

The readout command consists of three data bytes, which are denoted as “ADR”, “CMD”, and “NUL” in sequence. The definition of each parameter is described on Table 2.

Table 2. Contents of readout command

Byte sequence	Syntax	Value	Description
Byte 1	ADR	D0H	Write data to I2C address 68H
Byte 2	CMD	4EH	Data readout request command
Byte 3	NUL	00H	Null byte

3. Response format (slave to master)

After receiving a readout command from the master device, the slave device will response it a data packet consisting of 525 bytes. The responding data packet includes 9 bytes of header, 4 bytes of ambient temperature reading, and 512 bytes of object temperature reading.

Table 5. Contents of response data packet

Byte 1~9	Byte 10~13	Byte14~525
header	ambient temperature	object temperature

3.1 Contents of packet header

The packet header contains background information of the data packet, such as array size and packet sequence number. See Table 6 for details.

Table 6. Details of header bytes

Byte sequence	Syntax	Value	Description
Byte 1	STX	02H	Delimiter: start of header
Byte 2	RESP	4EH	Indicates this data packet is a response to a readout command.
Byte 3	n/a	n/a	(Reserved)
Byte 4	ASDS	xxH	Bit[7:4] TP array size - 0010: 16x16 - Others: (reserved) Bit[3:0] Sequence of data packet - 0000: the 1 st data packet - 0001: the 2 nd data packet - ... - 1111: the 16 th data packet (note: this sequence is used to identify whether the reading data packet is an updated one.)
Byte 5~8	n/a	n/a	(Reserved)
Byte 9	EXT	03H	Delimiter: stop of header

3.2 Ambient temperature reading

The ambient temperature reading is embedded in in Byte 12 and Byte 13 in the data packet.

Table 7. Details of ambient temperature bytes

Byte sequence	Syntax	Value	Description
Byte 10	AMB_H	xxH	High byte of ambient temperature reading
Byte 11	AMB_L	xxH	Low byte of ambient temperature reading



Byte 12	n/a	n/a	(Reserved)
Byte 13	n/a	n/a	(Reserved)

According to the contents of Byte 10 (AMB_H) and Byte 11 (AMB_L), we can calculate the exact ambient temperature reading by the follow equation:

$$T_{AMB} = [(AMB_H * 256 + AMB_L) - 27315] / 100$$

where

- (1) The T_{AMB} represents sensor's ambient temperature reading, which unit is degree-C;
- (2) The valid decimal digits are at the second decimal place.

3.3 Object temperature reading

The object temperature readings can be read from 256 sensing elements. The pixel coordinate of each sensing elements is defined as Figure 3.

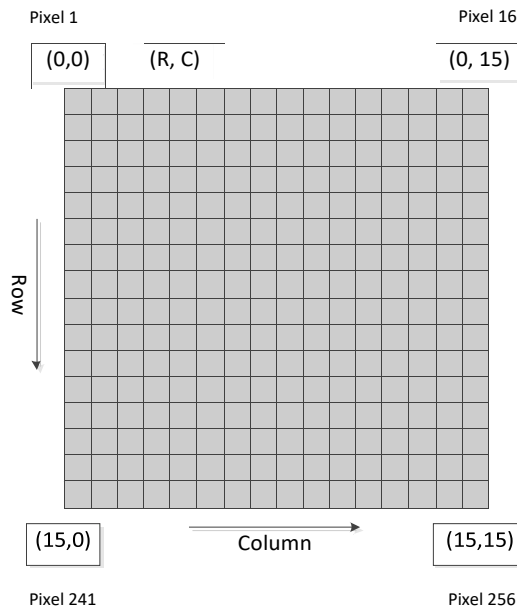

Figure 3. The coordinate of sensing elements

Each pixel's temperature reading is embedded in two data bytes in data packet. The relationship between reading byte sequence and pixel's coordinate is shown as Table 8 and Table 9.

Table 8. Relationship between reading bytes and object pixels

Byte 14	Byte 15
Pixel 1 (Hi-byte)	Pixel 1 (Low-byte)
.....	
Byte 524	Byte 525
Pixel 256 (Hi-byte)	Pixel 256 (Low-byte)

Table 9. Details of object temperature bytes

Byte sequence	Syntax	Value	Description
Byte 14	OBJ1_H	xxH	High byte of object temperature of pixel 1
Byte 15	OBJ1_L	xxH	Low byte of object temperature of pixel 1
Byte 16	OBJ2_H	xxH	High byte of object temperature of pixel 2
Byte 17	OBJ2_L	xxH	Low byte of object temperature of pixel 2
...	OBJn_H	xxH	High byte of object temperature of pixel n
...	OBJn_L	xxH	Low byte of object temperature of pixel n
Byte 524	OBJ256_H	xxH	High byte of object temperature of pixel 256
Byte 525	OBJ256_L	xxH	Low byte of object temperature of pixel 256

