

Evaluating the ADA4870 High Speed, High Output Current Amplifier

FEATURES

- ▶ Enables easy evaluation of the [ADA4870](#)
- ▶ Single-supply or dual-supply operation
- ▶ Robust thermal management

APPLICATIONS

- ▶ Organic light-emitting diode (OLED) panel driver
- ▶ Active matrix organic light-emitting diode (AMOLED) panel driver
- ▶ Base transceiver station (BTS) envelope tracking
- ▶ Power field effect transistor (FET) driver
- ▶ Ultrasound
- ▶ Piezoelectric driver
- ▶ PIN diode driver
- ▶ Waveform generation
- ▶ Automatic test equipment (ATE)
- ▶ Charge-coupled device (CCD) panel driver

GENERAL DESCRIPTION

The [ADA4870](#) is a 40 V, unity-gain stable, high speed current feedback amplifier capable of delivering 1 A of output current from a 40 V supply. Manufactured using the Analog Devices, Inc., proprietary high voltage XFCB process, the innovative architecture of the ADA4870 enables high output power, high speed signal processing solutions in a variety of demanding applications.

The ADA4870 is ideal for driving high voltage power FETs, piezoelectric transducers, PIN diodes, and a variety of other demanding applications that require high speed from high supply voltage and high current output.

The ADA4870 is available in a power SOIC package (PSOP_3) featuring an exposed thermal slug that provides high thermal conductivity to the printed circuit board (PCB) and heat sink enabling efficient heat transfer for improved reliability in demanding environments. The ADA4870 operates over the industrial temperature range of -40°C to $+85^{\circ}\text{C}$.

The ADA4870ARR-EBZ evaluation board provides a platform for quick and easy evaluation of the ADA4870. [Figure 1](#) shows the top side of the evaluation board. [Figure 2](#) shows the bottom side of the board with the large exposed copper area for applying a heat sink as needed.

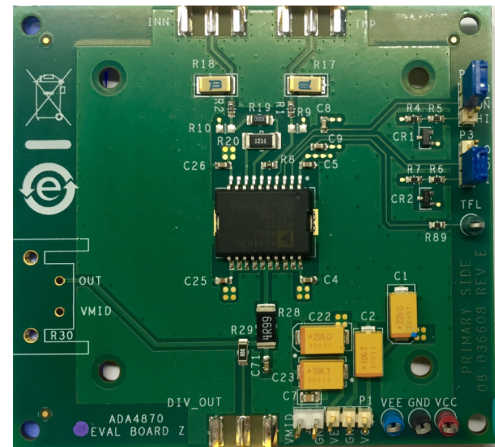

Figure 1. Evaluation Board, Top Side

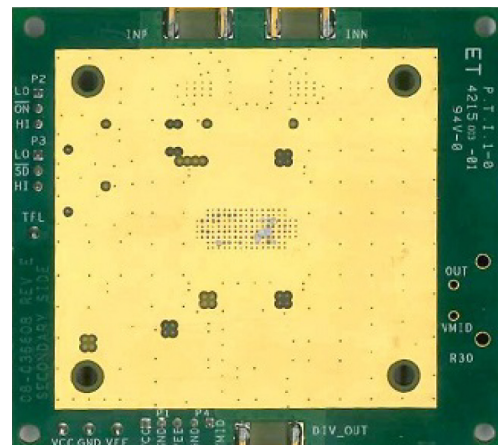

Figure 2. Evaluation Board, Bottom Side

TABLE OF CONTENTS

Features.....	1	$\overline{\text{ON}}$, Initial Power-Up, and Short Circuit.....	4
Applications.....	1	Shutdown ($\overline{\text{SD}}$).....	4
General Description.....	1	Thermal Monitor/Short-Circuit Flag (TFL).....	5
Evaluation Board Hardware.....	3	Thermal Design and Heat Sink Selection.....	5
Board Stack Up.....	3	Thermal Performance.....	6
Power Supplies and Decoupling.....	3	Evaluation Board Schematic.....	7
Input and Output.....	3	Ordering Information.....	8
Symmetrical Supplies and DC-Coupled		Bill of Materials.....	8
Inputs.....	3	Notes.....	9
Asymmetrical Supplies and Mid Supply Bias			
(VMID)	3		

REVISION HISTORY**11/2022—Rev. A to Rev. B**

Changes to Figure 7.....	6
--------------------------	---

EVALUATION BOARD HARDWARE

BOARD STACK UP

The ADA4870ARR-EBZ evaluation board is a 6-layer board. All signal routing is on the top layer; the bottom layer is an exposed copper ground plane to facilitate the use of a heat sink. The heat sink is needed for high power dissipation projects, such as driving a 20 Ω load with the maximum output swing. The internal layers (Layer 2 through Layer 5) consist of the GND, VCC, VMID, and VEE planes.

POWER SUPPLIES AND DECOUPLING

The evaluation board can be powered using a single supply or dual supplies. The total supply voltage ($V_{CC} - V_{EE}$) must be between 10 V and 40 V. The board provides sufficient power supply decoupling for high current, fast slewing signals with 22 μF and 10 μF tantalum capacitors installed at C1 and C2 where the V_{CC} supply voltage is applied to the board; 22 μF and 10 μF tantalum capacitors are installed at C22 and C23 where the V_{EE} supply voltage is applied to the board. In addition, 0.1 μF ceramic chip capacitors (C4 and C5) are placed in close proximity to the VCC pins (Pin 1, Pin 18, Pin 19, and Pin 20). And 0.1 μF ceramic chip capacitors (C25 and C26) are placed in close proximity to the VEE pins (Pin 10, Pin 11, Pin 12, and Pin 13).

INPUT AND OUTPUT

Figure 10 shows the evaluation board schematic for the factory default settings when the board is shipped.

The evaluation board uses edge-mount SMA connectors on the inputs and outputs for easy interfacing to signal sources and test equipment. When evaluating high voltage output signals using standard 50 Ω test equipment, R29 can be replaced with a 2.45 k Ω resistor that provides a signal division of 49.6 at the DIV_OUT SMA connector. The board can accommodate a capacitor load (C71) referenced to GND, and/or a power resistor in the TO-220 package (R30) referenced to VMID.

When using input signals of 5 V and lower, the board is equipped with 49.9 Ω , 0.25 W resistors at R17 and R18 that are capable of handling the power when using the factory default settings. The factory default configuration provides for operation on dual symmetrical supplies in noninverting and inverting gains of +4.5 V/V and -4.0 V/V, respectively. For single-supply and asymmetrical supply operation, see the [Asymmetrical Supplies and Mid Supply Bias \(VMID\)](#) section and [Table 1](#) for guidance on configuring the input terminations and supply settings.

SYMMETRICAL SUPPLIES AND DC-COUPLED INPUTS

Figure 3 shows the noninverting or inverting configuration schematic when using dual, symmetrical supplies. When using the factory

default settings with noninverting input, the ground reference is established through the 49.9 Ω termination resistors (R17 and R18), and the gain can be calculated using $R20/(R19 + R18)$. The gain is +4.5 V/V for the factory default settings. When using the factory default settings with inverting input, the gain can be calculated using $R20/R19$. The gain is -4.0 V/V for the factory default settings. In dual-supply operation when installing R30 in either inverting or noninverting applications, position the jumper at P4 to short VMID to GND.

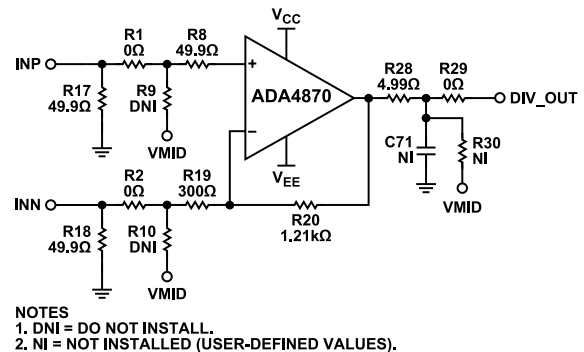

Figure 3. Schematic of Dual, Symmetrical Supplies with Noninverting or Inverting Input

ASYMMETRICAL SUPPLIES AND MID SUPPLY BIAS (VMID)

Figure 4 and Figure 5 show schematics when using a single supply with ac-coupled input.

The ADA4870 must be referenced to a dc operating point. When using a single supply or asymmetrical dual supplies, apply the appropriate reference voltage to the VMID pin of P4 using a low impedance source, such as a dc supply. The recommended VMID reference voltage is $V_{EE} + (V_{CC} - V_{EE})/2$.

When ac coupling into the noninverting input (INP), the dc operating point of the amplifier can be established by installing a resistor at R9 connected to VMID and replacing R1 with an ac coupling capacitor (C1), as shown in Figure 4. The ac coupling capacitor (C1) combined with the VMID bias resistor (R9) form a high-pass filter with the cutoff frequency at $1/(2 \times \pi \times R9 \times C1)$. The value of the ac coupling capacitor (C1) can be calculated based on the desired cutoff frequency.

When ac coupling into the inverting input (INN), the dc operating point of the amplifier can be established by shorting R9 to VMID. Do not install R1.

EVALUATION BOARD HARDWARE

THERMAL MONITOR/SHORT-CIRCUIT FLAG (TFL)

The TFL pin can be used to monitor relative changes in die temperature and to detect a short-circuit condition. During normal operation, the TFL pin outputs a dc voltage that is approximately 1.7 V (typical) above V_{EE} and is related to the die temperature. The TFL voltage changes at approximately -3 mV/°C. When the die temperature exceeds approximately 140°C, the amplifier switches to an off state, dropping the supply current to approximately 5 mA while TFL continues to report a voltage indicative of the die temperature. When the die temperature returns to an acceptable level, the amplifier automatically resumes normal operation.

THERMAL DESIGN AND HEAT SINK SELECTION

In some applications, the [ADA4870](#) may be required to dissipate as much as 10 W at elevated ambient temperatures of up to +85°C.

The evaluation board provides robust thermal management under these conditions.

The top of the board has an exposed copper area to which the ADA4870 PSOP package must be soldered. The exposed copper area allocated to the attachment of the PSOP slug is connected to the exposed copper ground plane on the bottom by an array of 136 thermal vias. A single internal ground layer (Layer 2) is also attached. [Figure 6](#) shows a model of the ADA4870 package mounted to the evaluation board with an applied heat sink.

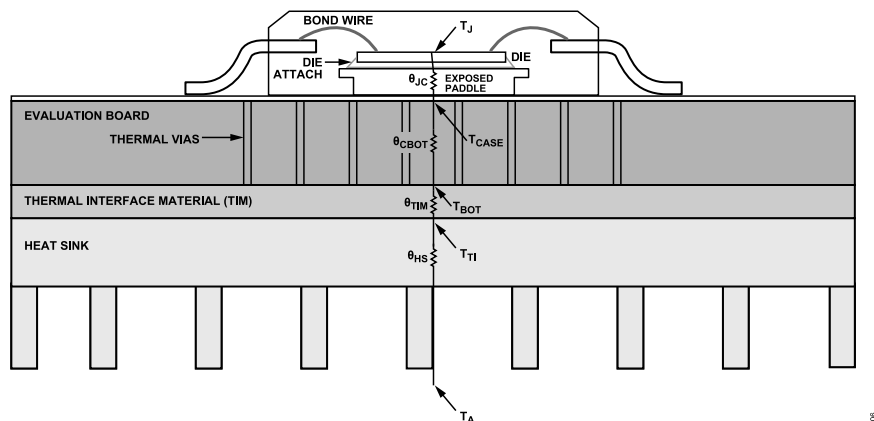

Figure 6. Thermal Model for ADA4870 with Heat Sink

EVALUATION BOARD HARDWARE

When necessary, a heat sink can be mounted to the bottom exposed copper using the mounting holes and an applied thermal interface material (TIM), such as the GC Electronics 10-8109. Refer to the manufacturer guidelines when applying the TIM; the TIM thermal resistance (θ_{TIM}) must be no more than 0.3°C/W. See Figure 7 for the dimensions of the heat sink and mounting hole locations. The approximate thermal resistance of the heat sink can be calculated from Equation 1, where θ_{JC} equals 1.1°C/W and θ_{CBOT} is approximately equal to 1.0°C/W. A heat sink having a thermal resistance of 4.2°C/W allows 10 W of power dissipation at an ambient temperature of 85°C.

$$\theta_{HS} = \left(\frac{T_J - T_A}{P_{DISS}} \right) - (\theta_{JC} + \theta_{CBOT} + \theta_{TIM}) \tag{1}$$

where:

T_J is the junction temperature.

T_A is the ambient temperature.

P_{DISS} is the chip power dissipation.

θ_{JC} is the chip thermal resistance.

θ_{CBOT} is the thermal resistance of the chip solder material and the PCB.

θ_{TIM} is the TIM thermal resistance.

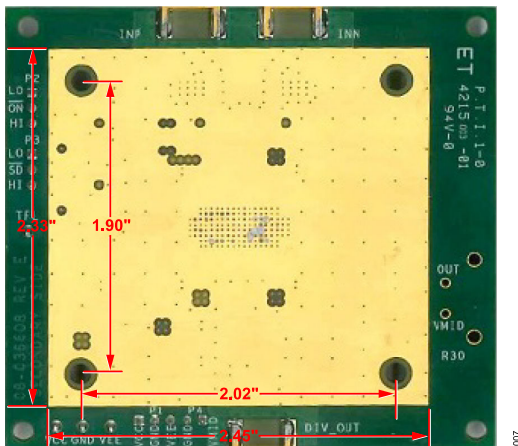

Figure 7. Dimensions of the Heat Sink and Mounting Holes

THERMAL PERFORMANCE

Figure 8 and Figure 9 show the die temperature vs. time while the internal power dissipation is increased over several hours. The ambient environment for Figure 8 is 25°C in still air; for Figure 9, the ambient environment is 85°C in still air. Figure 8 shows the die temperature in two conditions: one without a heat sink and the other with a heat sink rated at 5.4°C/W. Figure 9 shows the die temperature in three conditions: one without a heat sink, the second with a heat sink rated at 5.4°C/W, and the third with a heat sink rated at 4.2°C/W. For both Figure 8 and Figure 9, the board is positioned with the bottom side or heat sink facing up to facilitate natural convection. Using ac power dissipation and/or forced convection result in lower temperature.

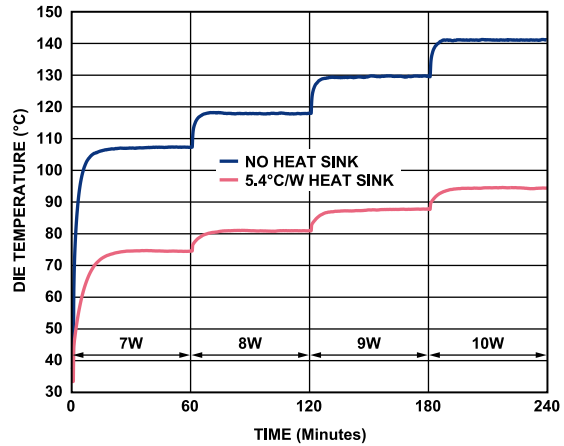

Figure 8. Die Temperature vs. Time and Internal Power Dissipation on the Evaluation Board, Ambient Temperature = 25°C, No Air Flow

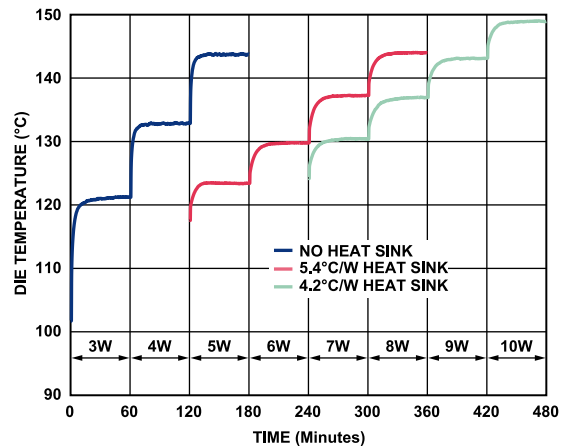

Figure 9. Die Temperature vs. Time and Internal Power Dissipation on the Evaluation Board, Ambient Temperature = 85°C, No Air Flow

EVALUATION BOARD SCHEMATIC

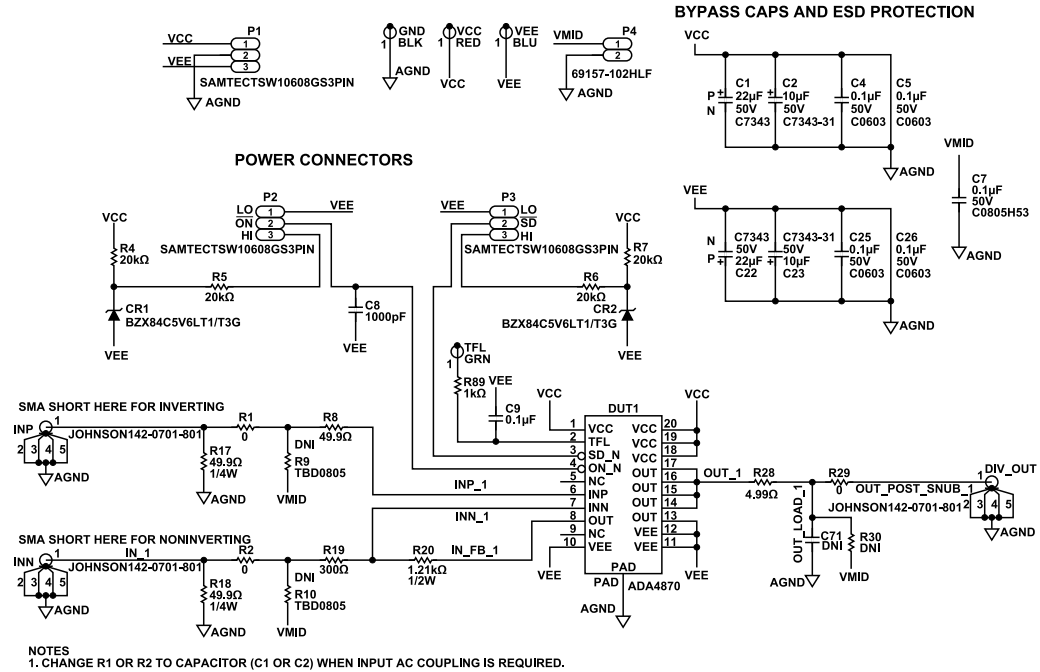

Figure 10. Evaluation Board Schematic

ORDERING INFORMATION

BILL OF MATERIALS

Table 2.

Item	Qty.	Reference Designator	Description	Value	Manufacturer/Part No.
1	1	Not applicable	ADA4870 evaluation board	Not applicable	Analog Devices/ADA4870ARR-EBZ
2	1	DUT1	ADA4870	Not applicable	Analog Devices/ADA4870
3	2	C1, C22	Capacitor, tantalum, 7343	22 μ F	AVX/TAJD226K050R
4	2	C2, C23	Capacitor, tantalum, 7343	10 μ F	AVX/TAJD106M050RNJ
5	5	C4, C5, C9, C25, C26	Capacitor, ceramic, X7R, 0603	0.1 μ F	AVX/06035C104KAT2A
6	1	C7	Capacitor, ceramic, X7R,0805, 50 V	0.1 μ F	Murata/GRM21BR71H104KA01L
7	1	C71	Capacitor, ceramic, COG, 0603, 50 V	Not installed	Murata/GRM1885C1H301JA01D
8	1	C8	Capacitor, ceramic, X7R, 0603, 50 V	1000 pF	AVX/06035C102KAT2A
9	2	CR1, CR2	Diode, Zener, SOT-23	5.6 V	ON Semiconductor/BZX84C5V6LT1/T3G
10	3	INP, INN, DIV_OUT	Connector, SMA end launch	Not applicable	Johnson/142-0701-801
11	1	GND	Connector, test point	Black	Components Corporation/TP104-01-00
12	3	P1, P2, P3	Connector, PCB, berg, header, straight, male, 3P	Not applicable	Samtec/TSW-103-08-G-S
13	1	P4	Connector, PCB, berg, jumper, straight, male, 2P	Not applicable	FCI/69157-102HLF
14	2	R1, R2	Resistor, 0603, jumper	0 Ω	Panasonic/EERJ-3GEY0R00V
15	2	R9, R10	Resistor, 0805	Not installed	
16	2	R17, R18	Resistor, 1206, 1%	49.9 Ω	Panasonic/ERJ-8ENF49R9V
17	1	R19	Resistor, 1206, 1%	300 Ω	Vishay Dale/CRCW1206300RFKEA
18	1	R20	Resistor, 2010, 1%	1.21 k Ω	Panasonic/ERJ-12SF1211U
19	1	R28	Resistor, 2512, 1%	4.99 Ω	Vishay Dale/CRCW25124R99FKEG
20	1	R29	Resistor, 1206, jumper	0 Ω	Vishay Dale/CRCW12060000Z0EA
21	1	R30	Resistor, TO-220	Not installed	
22	4	R4, R5, R6, R7	Resistor, 0603, 1%	20 k Ω	Panasonic/ERJ-3EKF2002V
23	1	R8	Resistor, 0603, 1%	49.9 Ω	Panasonic/ERJ-3EKF49R9V
24	1	R89	Resistor, 0603, 1%	1 k Ω	Panasonic/ERJ-3EKF1001V
25	1	TFL	Connector, test point	Green	Components Corporation/TP104-01-05
26	1	VCC	Connector, test point	Red	Components Corporation/TP104-01-02
27	1	VEE	Connector, test point	Blue	Components Corporation/TP104-01-06
28	2	Jumper	Jumper socket for P2 and P3	Not applicable	FCI/65474-001LF

ORDERING INFORMATION**NOTES****ESD Caution**

ESD (electrostatic discharge) sensitive device. Charged devices and circuit boards can discharge without detection. Although this product features patented or proprietary protection circuitry, damage may occur on devices subjected to high energy ESD. Therefore, proper ESD precautions should be taken to avoid performance degradation or loss of functionality.

Legal Terms and Conditions

By using the evaluation board discussed herein (together with any tools, components documentation or support materials, the "Evaluation Board"), you are agreeing to be bound by the terms and conditions set forth below ("Agreement") unless you have purchased the Evaluation Board, in which case the Analog Devices Standard Terms and Conditions of Sale shall govern. Do not use the Evaluation Board until you have read and agreed to the Agreement. Your use of the Evaluation Board shall signify your acceptance of the Agreement. This Agreement is made by and between you ("Customer") and Analog Devices, Inc. ("ADI"), with its principal place of business at Subject to the terms and conditions of the Agreement, ADI hereby grants to Customer a free, limited, personal, temporary, non-exclusive, non-sublicensable, non-transferable license to use the Evaluation Board FOR EVALUATION PURPOSES ONLY. Customer understands and agrees that the Evaluation Board is provided for the sole and exclusive purpose referenced above, and agrees not to use the Evaluation Board for any other purpose. Furthermore, the license granted is expressly made subject to the following additional limitations: Customer shall not (i) rent, lease, display, sell, transfer, assign, sublicense, or distribute the Evaluation Board; and (ii) permit any Third Party to access the Evaluation Board. As used herein, the term "Third Party" includes any entity other than ADI, Customer, their employees, affiliates and in-house consultants. The Evaluation Board is NOT sold to Customer; all rights not expressly granted herein, including ownership of the Evaluation Board, are reserved by ADI. CONFIDENTIALITY. This Agreement and the Evaluation Board shall all be considered the confidential and proprietary information of ADI. Customer may not disclose or transfer any portion of the Evaluation Board to any other party for any reason. Upon discontinuation of use of the Evaluation Board or termination of this Agreement, Customer agrees to promptly return the Evaluation Board to ADI. ADDITIONAL RESTRICTIONS. Customer may not disassemble, decompile or reverse engineer chips on the Evaluation Board. Customer shall inform ADI of any occurred damages or any modifications or alterations it makes to the Evaluation Board, including but not limited to soldering or any other activity that affects the material content of the Evaluation Board. Modifications to the Evaluation Board must comply with applicable law, including but not limited to the RoHS Directive. TERMINATION. ADI may terminate this Agreement at any time upon giving written notice to Customer. Customer agrees to return to ADI the Evaluation Board at that time. LIMITATION OF LIABILITY. THE EVALUATION BOARD PROVIDED HEREUNDER IS PROVIDED "AS IS" AND ADI MAKES NO WARRANTIES OR REPRESENTATIONS OF ANY KIND WITH RESPECT TO IT. ADI SPECIFICALLY DISCLAIMS ANY REPRESENTATIONS, ENDORSEMENTS, GUARANTEES, OR WARRANTIES, EXPRESS OR IMPLIED, RELATED TO THE EVALUATION BOARD INCLUDING, BUT NOT LIMITED TO, THE IMPLIED WARRANTY OF MERCHANTABILITY, TITLE, FITNESS FOR A PARTICULAR PURPOSE OR NON-INFRINGEMENT OF INTELLECTUAL PROPERTY RIGHTS. IN NO EVENT WILL ADI AND ITS LICENSORS BE LIABLE FOR ANY INCIDENTAL, SPECIAL, INDIRECT, OR CONSEQUENTIAL DAMAGES RESULTING FROM CUSTOMER'S POSSESSION OR USE OF THE EVALUATION BOARD, INCLUDING BUT NOT LIMITED TO LOST PROFITS, DELAY COSTS, LABOR COSTS OR LOSS OF GOODWILL. ADI'S TOTAL LIABILITY FROM ANY AND ALL CAUSES SHALL BE LIMITED TO THE AMOUNT OF ONE HUNDRED US DOLLARS (\$100.00). EXPORT. Customer agrees that it will not directly or indirectly export the Evaluation Board to another country, and that it will comply with all applicable United States federal laws and regulations relating to exports. GOVERNING LAW. This Agreement shall be governed by and construed in accordance with the substantive laws of the Commonwealth of Massachusetts (excluding conflict of law rules). Any legal action regarding this Agreement will be heard in the state or federal courts having jurisdiction in Suffolk County, Massachusetts, and Customer hereby submits to the personal jurisdiction and venue of such courts. The United Nations Convention on Contracts for the International Sale of Goods shall not apply to this Agreement and is expressly disclaimed.

