

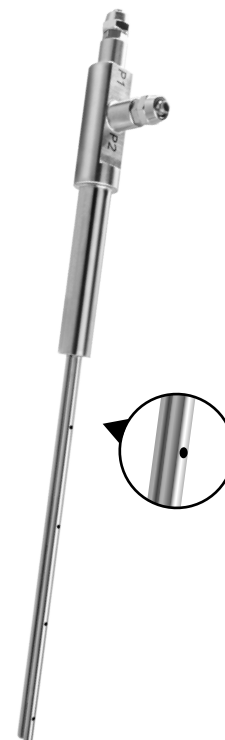

PHD330

Industrial Differential Pressure Transmitter

eyc-tech PHD330  
Industrial Grade Differential Pressure Transmitter



Match with  
eyc-tech AFMT Average Flow Measuring Tube  
(Pitot tube)

## | Features |

- Silicon chips on differential pressure module of MEMS integration technology
- Offset function / UI software
- Low-pressure monitoring, high pressure resistance
- RS-485 communication interface(Optional), Modbus RTU protocol
- Physical unit switch(User Interface) : mbar / Pa / hPa / kPa / mmH<sub>2</sub>O / mmWS / inH<sub>2</sub>O / mmHg
- Square root function

## | Introduction |

The eyc-tech PHD330 differential pressure transmitter is designed on the MEMS hot wire anemometer architecture, which has very good zero point stability and small differential pressure detection capability, high pressure resistance. The transmitter uses the pressure difference to pass a very small amount of gas through the air flow channel of the sensor body. Combined with the integrated circuit to convert into a differential pressure signal.

## | Applications |

Exhaust emission / Environmental engineering / Air duct / Filter /  
Monitor differential pressure and environment air flow

## | Specification |

### Input

Input type	Piezoelectric differential pressure module
Measuring range	$\pm 50 \dots \pm 10000 \text{ pa}$

### Output

Output	4 ... 20 mA / 0 ... 10 V
Signal connection	3-wire
Modbus	RS-485
Load resistance	4 ... 20 mA <math>\leq 500 \Omega</math> / 0 ... 10 V <math>\geq 100 \text{ K}\Omega</math>
(Current output)	
Response time( $t_{63}$ )	$\leq 2 \text{ ms}$
Display type	LCD Module with back light, double line character
Display range	V=Air velocity(at 25°C) Q=Air quantity(with eyc-tech AFMT)
Digit height	5.56 mm

### Environment

Measuring medium	Air
Operating temperature	-20 ... +80°C(Non-display) 0 ... +50°C(Display)
Operating humidity	0 ... 95%RH(Non-condensing)
Storage temperature	-40 ... +80°C

### Accuracy

Accuracy	$\pm 2.0\% \text{ F.S.}$
Temperature influence	$\pm 1.75\% (5 \dots 55^\circ\text{C})$

### Electrical

Power supply	AC 24 V $\pm 10\%$ / DC 24 V $\pm 10\%$
Current consumption	DC 24 V : $\leq 45 \text{ mA(} \text{Display)} / \leq 40 \text{ mA(} \text{Non-display)}$ AC 24 V : $\leq 95 \text{ mA(} \text{Display)} / \leq 90 \text{ mA(} \text{Non-display)}$
Overvoltage protection	$\leq \text{DC } 40 \text{ V}$
Electrical connection	M12 connector

### Installation

Installation	Wall
--------------	------

### Protection

IP rating	IP65
Electrical protection	■ Polarity protection ■ Over-voltage ■ Short circuit
Pressure resistance	$\pm 50 \dots \pm 500 \text{ pa} : 0.25 \text{ bar}$ $\pm 1000 \dots \pm 10000 \text{ pa} : 0.5 \text{ bar}$
Burst pressure	$\pm 50 \dots \pm 2500 \text{ pa} : 0.75 \text{ bar}$ $\pm 5000 \dots \pm 10000 \text{ pa} : 1.25 \text{ bar}$

### Certification

Certification	CE
---------------	----

### Material

Housing	Aluminum alloy
Weight	Display : 497 g ; Non-display : 478 g

\*Please make sure the product and the device which connect with RS-485 are on common ground, avoid damaged product.

## | Pressure Unit Conversion Table |

Unit	Pa	mbar	hPa	kPa	mmWS	inH <sub>2</sub> O	mmHg
Range	$\pm 50 / 100$	0.5 / 1	0.5 / 1	0.05 / 0.1	5 / 10	0.2 / 0.4	0.375 / 0.75
	$\pm 300 / 500$	3 / 5	3 / 5	0.3 / 0.5	30 / 50	1.2 / 2	2.25 / 3.75
	$\pm 1000 / 1600 / 2500$	10 / 16 / 25	10 / 16 / 25	1 / 1.6 / 2.5	100 / 160 / 250	4 / 6.4 / 10	7.5 / 12 / 18.75
	$\pm 5000 / 7500 / 10000$	50 / 75 / 100	50 / 75 / 100	5 / 7.5 / 10	500 / 750 / 1000	20 / 30 / 40	37.5 / 56.25 / 75

## | Dimension |

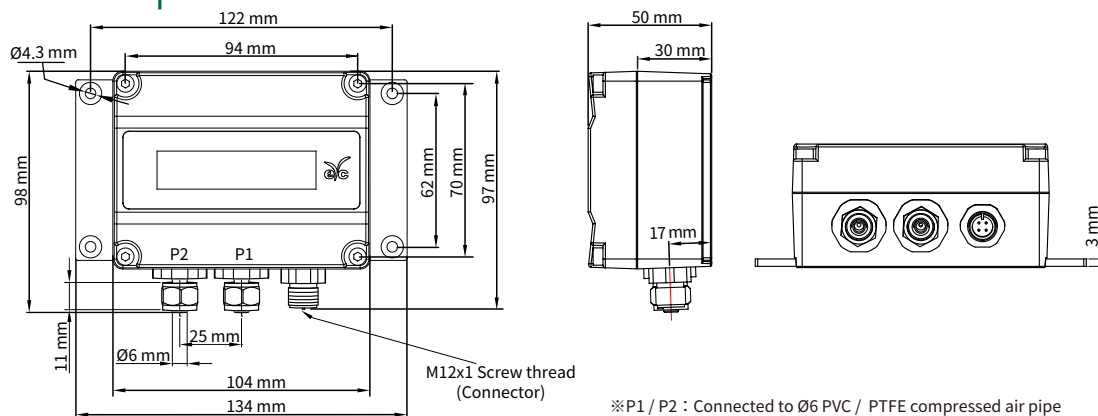

## Connection Diagram

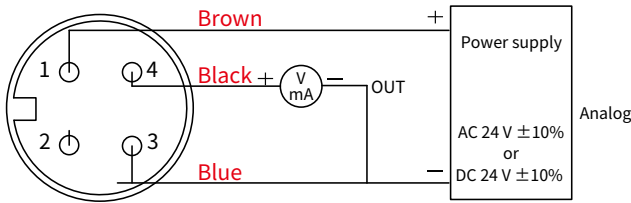

4P M12 Connector + Analog

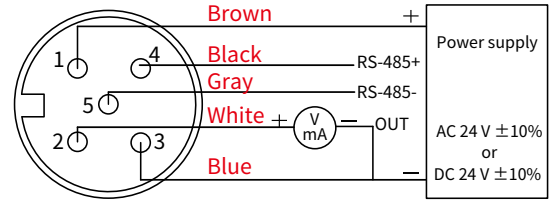

5P M12 Connector+RS-485

## Theory

eyc-tech PHD330 Industrial Grade Differential Pressure Transmitter is built on the structure of thermal mass flow measurement, with eyc-tech AFMT Average Flow Measuring Tube(Pitot tube), based on the flow continuity formula (the law of conservation of mass) and the Bernoulli formula (the law of conservation of energy), the wind speed calculation formula is deduced to achieve an effective and accurate measurement.

### Flow rate formula

$$V = K \sqrt{\frac{2}{\rho} \Delta P}$$

### Flow formula

$$qv = K \epsilon A \sqrt{\frac{2}{\rho} \Delta P}$$

$$qm = qv \times \rho$$

V = Velocity of the liquid(m/s)

$\Delta P$  = Difference between total pressure and static pressure

(Dynamic pressure)(Pa)

$\rho$  = Flow density(kg/m<sup>3</sup>)

K = Flow coefficient

qv = Volume flow of liquid(m<sup>3</sup>/s)

qm = Mass flow of liquid(kg/s)

K = Flow coefficient of average flow measuring

$\epsilon$  = Inflation coefficient of liquid going thru measuring tube during operation

A = Cross-sectional area of duct during operation(m<sup>2</sup>)

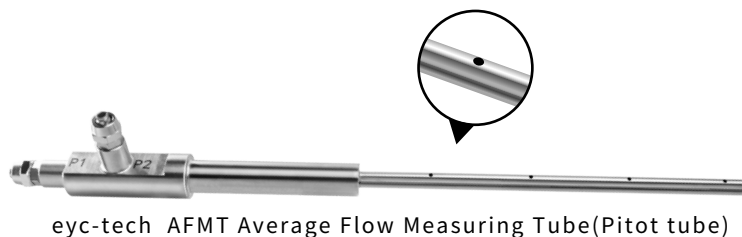
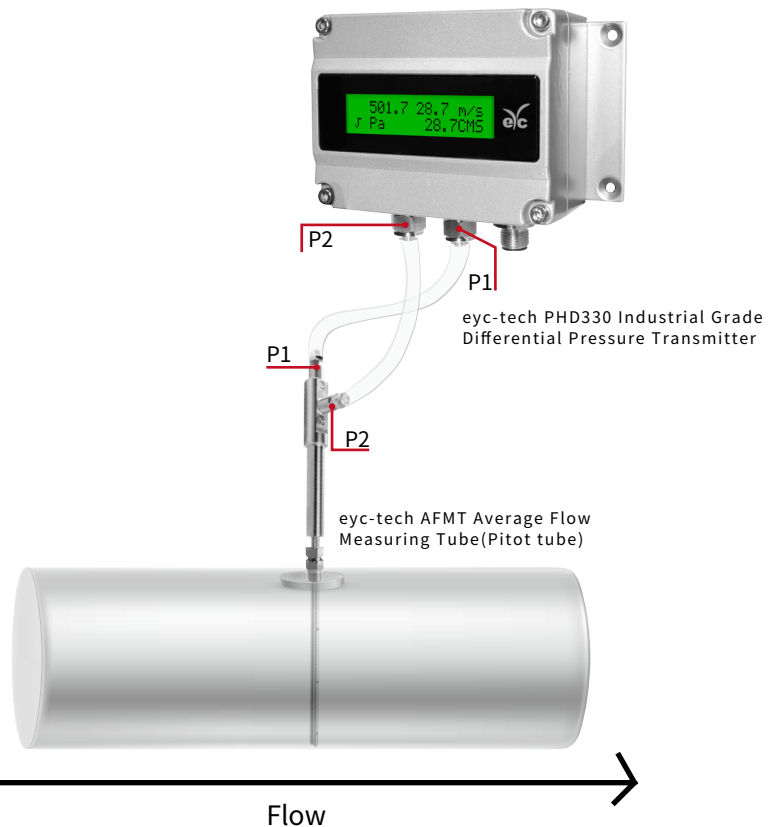

eyc-tech AFMT Average Flow Measuring Tube(Pitot tube)

## | Installation |

Varnished wire waste gas treatment product installation drawing

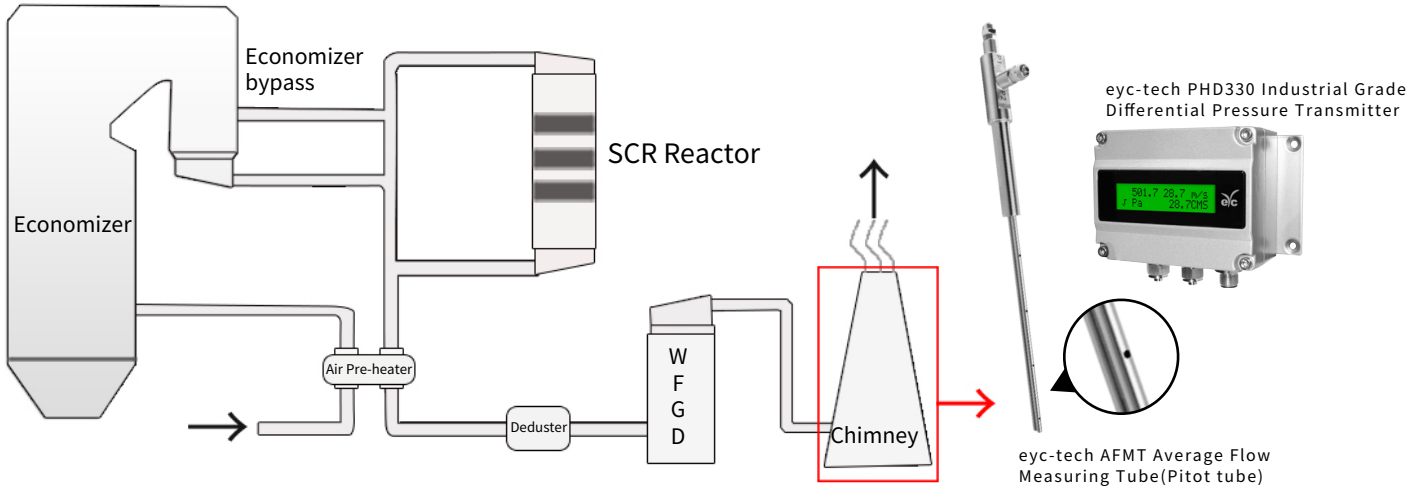

## | Ordering Guide |

PHD	Installation <b>330</b>	—	Range <b>20</b>	Output <b>1</b>	—	Electrical connection <b>M</b>	Optional <b>D</b>
	330 : Wall		10 : ±50 / 100 pa 20 : ±300 / 500 pa 30 : ±1000 / 1600 / 2500 pa 40 : ±5000 / 7500 / 10000 pa	1 : 4 ... 20 mA 6 : 0 ... 10 V		M : M12x1 connector(with 2m cable)	D : Display(LCD) 1 : RS-485

## | Additional Option Test Report | For more detailed information please contact us.

### ■ ISO 9001

Project	Measurand level or range
Pressure	Differential pressure : 0 ... 500 Pa / 0 ... 1000 Pa / 0 ... 10000 Pa