

# OA172SAP XC Salt Fog Series

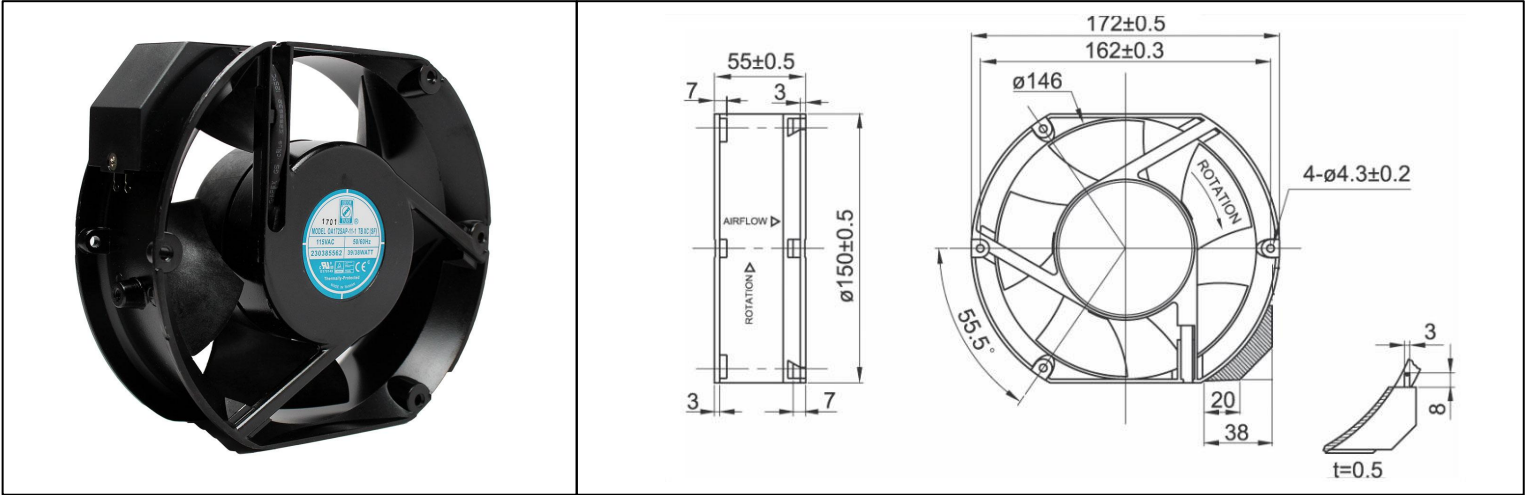

AC Fan - 115V, 230V  
172 x 150 x 55mm (6.7"x 5.9"x 2.2")



Frame	Diecast Aluminum	<u>Operating Temperature</u> -20C ~ +70C  <u>Storage Temperature</u> -30C ~ +80C  <u>Life Expectancy</u> 40,000 hours (L10 at 40C)  <u>Environmental Protection</u> Salt Fog Rated  Weight: ~ 2.4 lbs	
Impeller	PBT, UL94V-0 plastic		
Connection	Terminals		
Motor	AC Capacitor drive, Thermally protected		
Bearing System	Dual Ball Bearings		
Insulation Resistance	>100M ohm between leadwire and frame (500VDC)		
Dielectric Strength	1 min at 1500 VAC,50/60 Hz		
		m2	

Part Number	OA172SAP-11-1TBXCFSF	OA172SAP-22-1TBXCFSF
Rated Voltage	115 VAC	230 VAC
Voltage Range	103 ~ 126 VAC	207 ~ 253 VAC
Rated Power	38 W	38 W
Rated Current	0.34 A	0.17 A
Rated Speed (RPM)	3400	3400
Airflow (CFM)	293	293
Noise Level (dB)	60	60
Max. Static Pressure	0.90"H <sub>2</sub> O	0.90"H <sub>2</sub> O