



# +5V Multiprotocol, Software-Selectable Control Transceivers

MXL1544/MAX3175

## General Description

The MXL1544/MAX3175 are four-driver/four-receiver multiprotocol transceivers that operate from a single +5V supply in conjunction with the MXL1543. The MXL1544/MAX3175, along with the MXL1543 and MXL1344A, form a complete software-selectable data terminal equipment (DTE) or data communication equipment (DCE) interface port that supports the V.28 (RS-232), V.10/V.11 (RS-449/V.36, EIA-530, EIA-530A, X.21, RS-423), and V.35 protocols. The MXL1544/MAX3175 transceivers carry serial interface control signaling, while the MXL1543 carries the high-speed clock and data signals. Typically, the MXL1543 is terminated using the MXL1344A. The MAX3175 is identical to the MXL1544 except for the addition of a 10µs (typ) glitch rejection circuit at the receiver inputs. The MXL1544/MAX3175 are available in 28-pin SSOP packages.

## Applications

- Data Networking
- CSU and DSU
- Data Routers
- Switches
- PCI Cards
- Telecommunication Equipment

## Features

- ◆ MXL1544/MAX3175, MXL1543, MXL1344A Chipset Is Pin Compatible with LTC1544, LTC1543, LTC1344A Chipset
- ◆ Chipset Operates from a Single +5V Supply
- ◆ Software-Selectable DCE/DTE
- ◆ Supports V.28 (RS-232), V.10/V.11 (RS-449/V.36, EIA-530, EIA-530A, X.21, RS-423) Protocols
- ◆ Flow-Through Pin Configuration
- ◆ True Fail-Safe Operation
- ◆ Low 0.5µA Shutdown Current (No-Cable Mode)
- ◆ 10µs Receiver Input Deglitching (MAX3175 Only)
- ◆ TUV-Certified NET1/NET2 and TBR1/TBR2 Compliant

## Ordering Information

PART	TEMP. RANGE	PIN-PACKAGE
MXL1544CAI	0°C to +70°C	28 SSOP
MAX3175CAI	0°C to +70°C	28 SSOP

Pin Configuration appears at end of data sheet.

## Typical Operating Circuit

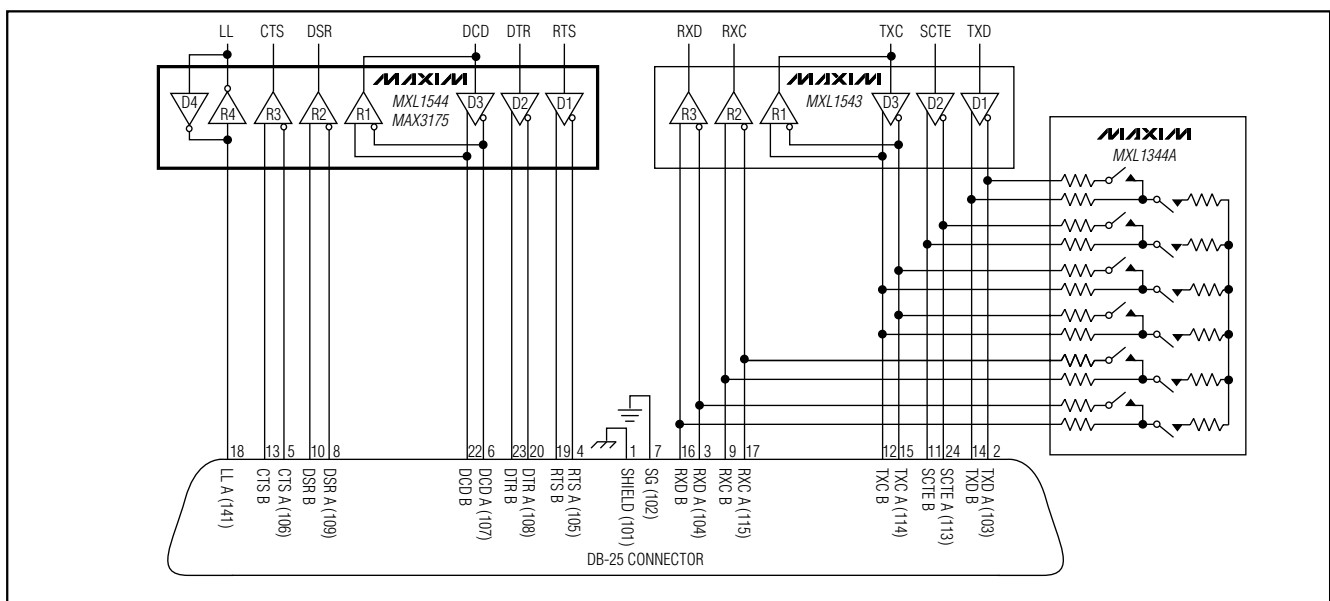

# +5V Multiprotocol, Software-Selectable Control Transceivers

## ABSOLUTE MAXIMUM RATINGS

All Voltages to GND Unless Otherwise Noted

### Supply Voltages

V <sub>CC</sub> .....	-0.3V to +6V
V <sub>DD</sub> .....	-0.3V to +7.2V
V <sub>EE</sub> .....	+0.3V to -7V
V <sub>DD</sub> to V <sub>EE</sub> (Note 1).....	13V

### Logic Input Voltage

M0, M1, M2, DCE/DTE, INVERT, T <sub>1IN</sub> .....	-0.3V to +6V
---	--------------

### Logic Output Voltage

R <sub>OUT</sub> .....	-0.3V to (V <sub>CC</sub> + 0.3V)
------------------------	-----------------------------------

### Transmitter Outputs

T <sub>OUT</sub> , T <sub>OUT</sub> /R <sub>IN</sub> .....	-15V to +15V
Short-Circuit Duration.....	Continuous

### Receiver Inputs

R <sub>IN</sub> , T <sub>OUT</sub> /R <sub>IN</sub> .....	-15V to +15V
Continuous Power Dissipation (T <sub>A</sub> = +70°C)	
28-Pin SSOP (derate 11.1mW/°C above +70°C).....	889mW
Operating Temperature Range.....	0°C to +70°C
Junction Temperature.....	+150°C
Storage Temperature Range.....	-65°C to +150°C
Lead Temperature (soldering, 10s).....	+300°C

**Note 1:** V<sub>DD</sub> and V<sub>EE</sub>- can have maximum magnitude of 7.2V and 7V, respectively, but their difference cannot exceed 13V.

Stresses beyond those listed under "Absolute Maximum Ratings" may cause permanent damage to the device. These are stress ratings only, and functional operation of the device at these or any other conditions beyond those indicated in the operational sections of the specifications is not implied. Exposure to absolute maximum rating conditions for extended periods may affect device reliability.

## ELECTRICAL CHARACTERISTICS

(V<sub>CC</sub> = +5V, V<sub>DD</sub> = +6.8V, V<sub>EE</sub> = -5.6V, T<sub>A</sub> = T<sub>MIN</sub> to T<sub>MAX</sub>, unless otherwise noted. Typical values are at T<sub>A</sub> = +25°C.) (Note 2)

PARAMETER	SYMBOL	CONDITIONS	MIN	TYP	MAX	UNITS
<b>POWER SUPPLIES</b>						
V <sub>CC</sub> Supply Current (DCE Mode) (Digital Inputs = GND or V <sub>CC</sub> ) (Transmitters Outputs Static)	I <sub>CC</sub>	RS-530, RS-530A, X.21, no load		2.7		mA
		RS-530, RS-530A, X.21, full load		95	120	
		V.28, no load		1	2	
		V.28, full load		1	2	
		No-cable mode, Invert = V <sub>CC</sub>		0.5	10	
V <sub>EE</sub> Supply Current (DCE Mode) (Digital Inputs = GND or V <sub>CC</sub> ) (Transmitters Outputs Static)	I <sub>EE</sub>	RS-530, RS-530A, X.21, no load		2.1		mA
		RS-530, X.21, full load		14		
		RS-530A, full load		25		
		V.28, no load		1		
		V.28, full load		12		
		No-cable mode		0.5		μA
V <sub>DD</sub> Supply Current (DCE Mode) (Digital Inputs = GND or V <sub>CC</sub> ) (Transmitters Outputs Static)	I <sub>DD</sub>	RS-530, RS-530A, X.21, no load		0.6		mA
		RS-530, RS-530A, X.21, full load		1		
		V.28, no load		1		
		V.28, full load		12		
		No-cable mode		0.5		
Internal Power Dissipation (DCE Mode)	P <sub>D</sub>	RS-530, RS-530A, X.21, full load		300		mW
		V.28, full load		54		
<b>LOGIC INPUTS (M0, M1, M2, DCE/DTE, INVERT, T1IN, T2IN, T3IN, T4IN)</b>						
Input High Voltage	V <sub>IH</sub>		2.0			V
Input Low Voltage	V <sub>IL</sub>				0.8	V
Logic Input Current	I <sub>IN</sub>	T1IN, T2IN, T3IN, T4IN			±10	μA
		M0, M1, M2, DCE/DTE, INVERT = GND	-100	-50	-30	
		M0, M1, M2, DCE/DTE, INVERT = V <sub>CC</sub>			±10	

# +5V Multiprotocol, Software-Selectable Control Transceivers

MXL1544/MAX3175

## ELECTRICAL CHARACTERISTICS (continued)

(V<sub>CC</sub> = +5V, V<sub>DD</sub> = +6.8V, V<sub>EE</sub> = -5.6V, T<sub>A</sub> = T<sub>MIN</sub> to T<sub>MAX</sub>, unless otherwise noted. Typical values are at T<sub>A</sub> = +25°C.) (Note 2)

PARAMETER	SYMBOL	CONDITIONS	MIN	TYP	MAX	UNITS
<b>LOGIC OUTPUTS (R1OUT, R2OUT, R3OUT, R4OUT)</b>						
Output High Voltage	V <sub>OH</sub>	I <sub>SOURCE</sub> = 4mA	3	4.5		V
Output Low Voltage	V <sub>OL</sub>	I <sub>SINK</sub> = 4mA		0.3	0.8	V
Output Short-Circuit Current	I <sub>SC</sub>	0 ≤ V <sub>OUT</sub> ≤ V <sub>CC</sub>	-50		50	mA
Output Pullup Current	I <sub>L</sub>	V <sub>OUT</sub> = 0, no-cable mode		70		μA
<b>RECEIVER INPUTS</b>						
Receiver Glitch Rejection		MAX3175 only	5	10	15	μs
<b>V.11 TRANSMITTER</b>						
Open-Circuit Differential Output Voltage	V <sub>ODO</sub>	Open circuit, R = 1.95kΩ (Figure 1)			±5	V
Loaded Differential Output Voltage	V <sub>ODL</sub>	R = 50Ω (Figure 1), T <sub>A</sub> = +25°C	0.5 × V <sub>ODO</sub>		0.67 × V <sub>ODO</sub>	V
		R = 50Ω (Figure 1)	±2			
Change in Magnitude of Output Differential Voltage	ΔV <sub>OD</sub>	R = 50Ω (Figure 1)			0.2	V
Common-Mode Output Voltage	V <sub>OC</sub>	R = 50Ω (Figure 1)			3	V
Change in Magnitude of Output Common-Mode Voltage	ΔV <sub>OC</sub>	R = 50Ω (Figure 1)			0.2	V
Short-Circuit Current	I <sub>SC</sub>	V <sub>OUT</sub> = GND			150	mA
Output Leakage Current	I <sub>Z</sub>	-0.25V < V <sub>OUT</sub> < +0.25V, power-off or no-cable mode		±1	±100	μA
Rise or Fall Time	t <sub>r</sub> , t <sub>f</sub>	R = 50Ω (Figures 2, 5)	2	15	25	ns
Transmitter Input to Output	t <sub>PHL</sub> , t <sub>PLH</sub>	R = 50Ω (Figures 2, 5)		50	75	ns
Data Skew	t <sub>PHL</sub> - t <sub>PLH</sub>	(Figures 2, 5)		3	12	ns
Output-to-Output Skew		(Figures 2, 5)		3		ns
<b>V.11 RECEIVER</b>						
Differential Input Voltage	V <sub>TH</sub>	-7V ≤ V <sub>CM</sub> ≤ 7V	-200		200	mV
Input Hysteresis	ΔV <sub>TH</sub>	-7V ≤ V <sub>CM</sub> ≤ 7V		15	40	mV
Receiver Input Current	I <sub>IN</sub>	-10V ≤ V <sub>AB</sub> ≤ 10V			±0.66	mA
Receiver Input Resistance	R <sub>IN</sub>	-10V ≤ V <sub>AB</sub> ≤ 10V	15	30		kΩ
Rise or Fall Time	t <sub>r</sub> , t <sub>f</sub>	(Figures 2, 6)		15		ns
Receiver Input to Output	t <sub>PHL</sub> , t <sub>PLH</sub>	(Figures 2, 6)	MXL1544	50	80	ns
			MAX3175	10		μs
Data Skew	t <sub>PHL</sub> - t <sub>PLH</sub>	(Figures 2, 6)	MXL1544	4	16	ns
			MAX3175	1		μs

# +5V Multiprotocol, Software-Selectable Control Transceivers

## ELECTRICAL CHARACTERISTICS (continued)

(V<sub>CC</sub> = +5V, V<sub>DD</sub> = +6.8V, V<sub>EE</sub> = -5.6V, T<sub>A</sub> = T<sub>MIN</sub> to T<sub>MAX</sub>, unless otherwise noted. Typical values are at T<sub>A</sub> = +25°C.) (Note 2)

PARAMETER	SYMBOL	CONDITIONS	MIN	TYP	MAX	UNITS
<b>V.10 TRANSMITTER</b>						
Open-Circuit Output Voltage Swing	V <sub>O</sub>	R <sub>L</sub> = 3.9kΩ (Figure 3)	±4		±6	V
Output Voltage Swing	V <sub>T</sub>	R <sub>L</sub> = 450Ω (Figure 3)	±3.6			V
		R <sub>L</sub> = 450Ω (Figure 3), T <sub>A</sub> = +25°C	0.9 x V <sub>O</sub>			
Short-Circuit Current	I <sub>SC</sub>	V <sub>O</sub> = GND, T <sub>A</sub> = +25°C			±150	mA
Output Leakage Current	I <sub>Z</sub>	-0.25V < V <sub>OUT</sub> < +0.25V, power-off or no-cable mode		±1	±100	μA
Rise or Fall Time	t <sub>r</sub> , t <sub>f</sub>	R <sub>L</sub> = 450Ω, C <sub>L</sub> = 100pF (Figures 3, 7)		2		μs
Transmitter Input to Output	t <sub>PHL</sub> , t <sub>PLH</sub>	R <sub>L</sub> = 450Ω, C <sub>L</sub> = 100pF (Figures 3, 7)		1		μs
<b>V.10 RECEIVER</b>						
Differential Threshold Voltage	V <sub>TH</sub>		-250		250	mV
Input Hysteresis	ΔV <sub>TH</sub>			25	50	mV
Receiver Input Current	I <sub>IN</sub>	-10V ≤ V <sub>A</sub> ≤ 10V			±0.66	mA
Receiver Input Impedance	R <sub>IN</sub>	-10V ≤ V <sub>A</sub> ≤ 10V	15	30		kΩ
Rise or Fall Time	t <sub>r</sub> , t <sub>f</sub>	(Figures 4, 8)		15		ns
Receiver Input to Output	t <sub>PLH</sub>	(Figures 4, 8)	MXL1544	55		ns
			MAX3175	10		μs
	t <sub>PHL</sub>		MXL1544	109		ns
			MAX3175	10		μs
Data Skew	t <sub>PHL</sub> - t <sub>PLH</sub>	(Figures 4, 8)	MXL1544	60		ns
			MAX3175	1		μs
<b>V.28 TRANSMITTER</b>						
Output Voltage Swing	V <sub>O</sub>	Open circuit (Figure 3)			±7	V
		R <sub>L</sub> = 3kΩ (Figure 3)	±5	±6		V
Short-Circuit Current	I <sub>SC</sub>	V <sub>O</sub> = GND			±150	mA
Output Leakage Current	I <sub>Z</sub>	-0.25V ≤ V <sub>OUT</sub> ≤ +0.25V, power-off or no-cable mode		±1	±100	μA
Output Slew Rate	SR	R <sub>L</sub> = 3kΩ, C <sub>L</sub> = 2500pF (Figures 3, 7)	4		30	V/μs
Transmitter Input to Output	t <sub>PHL</sub>	R <sub>L</sub> = 3kΩ, C <sub>L</sub> = 2500pF (Figures 3, 7)		1.5	2.5	μs
	t <sub>PLH</sub>			1.5	3	
<b>V.28 RECEIVER</b>						
Input Low Voltage	V <sub>IL</sub>			1.3	0.8	V
Input High Voltage	V <sub>IH</sub>		2.0	1.3		V
Input Hysteresis	V <sub>HYS</sub>			0.05	0.3	V
Input Resistance	R <sub>IN</sub>	-15V < V <sub>IN</sub> < +15V	3	5	7	kΩ
Rise or Fall Time	t <sub>r</sub> , t <sub>f</sub>	(Figures 4, 8)		15		ns

# +5V Multiprotocol, Software-Selectable Control Transceivers

MXL1544/MAX3175

## ELECTRICAL CHARACTERISTICS (continued)

( $V_{CC} = +5V$ ,  $V_{DD} = +6.8V$ ,  $V_{EE} = -5.6V$ ,  $T_A = T_{MIN}$  to  $T_{MAX}$ , unless otherwise noted. Typical values are at  $T_A = +25^\circ C$ .) (Note 2)

PARAMETER	SYMBOL	CONDITIONS	MIN	TYP	MAX	UNITS	
Receiver Input to Output	$t_{PLH}$	(Figures 4, 8)	MXL1544		60	100	ns
			MAX3175		10		$\mu s$
	$t_{PHL}$		MXL1544		70	450	ns
			MAX3175		10		$\mu s$

**Note 2:** MXL1544/MAX3175 are designed to operate with  $V_{DD}$  and  $V_{EE}$  supplied by the MXL1543 charge pump.

## Typical Operating Characteristics

( $T_A = +25^\circ C$ , unless otherwise noted.)

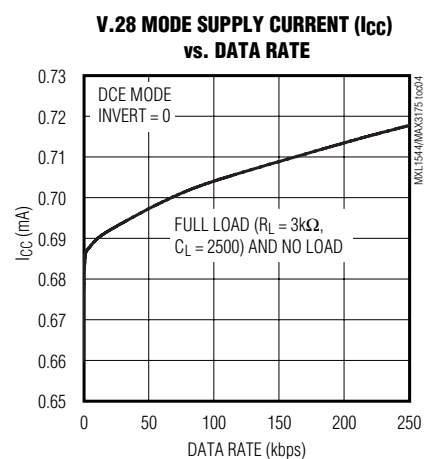
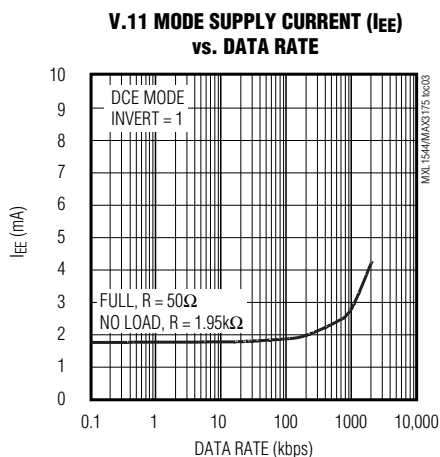
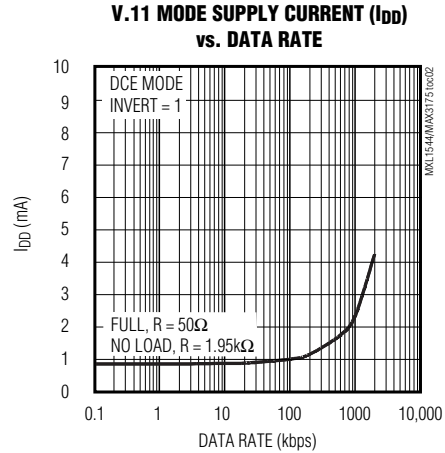
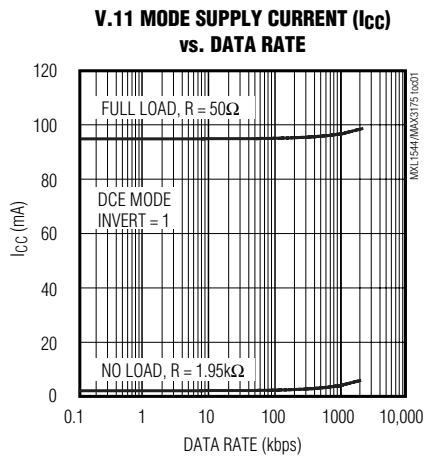

# +5V Multiprotocol, Software-Selectable Control Transceivers

## Typical Operating Characteristics (continued)

( $T_A = +25^\circ\text{C}$ , unless otherwise noted.)

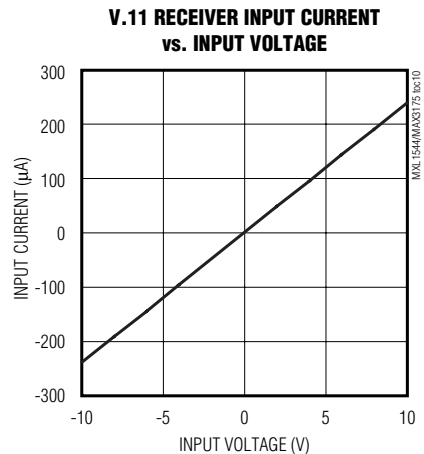
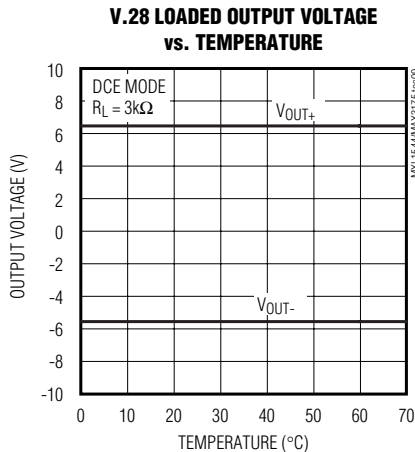
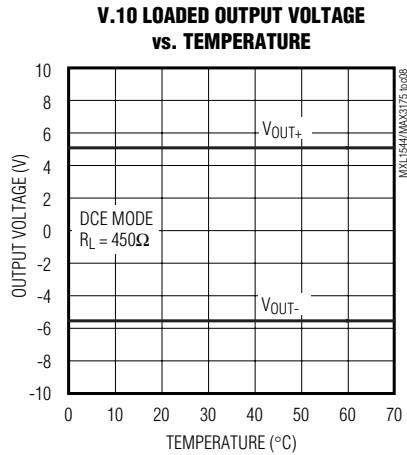
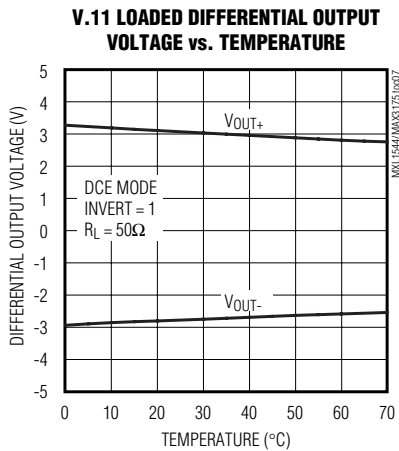
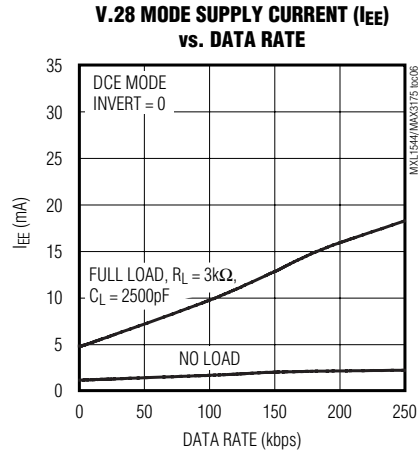
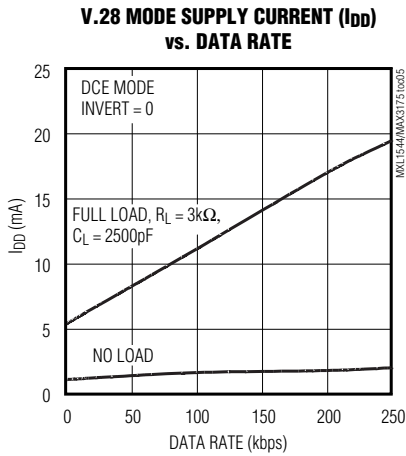

# +5V Multiprotocol, Software-Selectable Control Transceivers

MXL1544/MAX3175

## Typical Operating Characteristics (continued)

( $T_A = +25^\circ\text{C}$ , unless otherwise noted.)

**V.28 RECEIVER INPUT CURRENT vs. INPUT VOLTAGE**

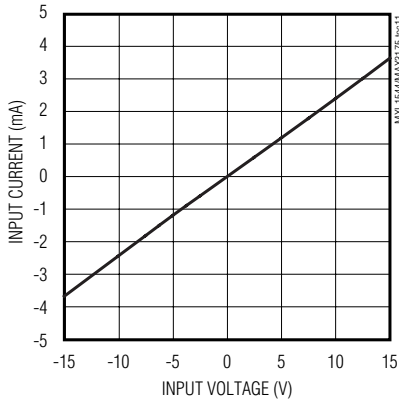

**V.28 SLEW RATE vs. LOAD CAPACITANCE**

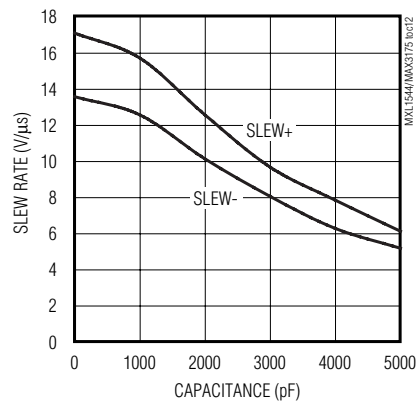

**V.10 TRANSMITTER RISE AND FALL TIME vs. LOAD CAPACITANCE**

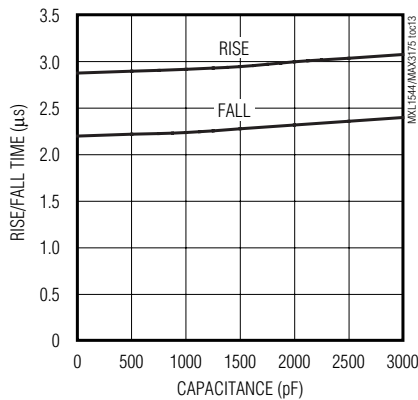

**MXL1544 LOOPBACK SCOPE PHOTO V.11 MODE (UNLOADED)**

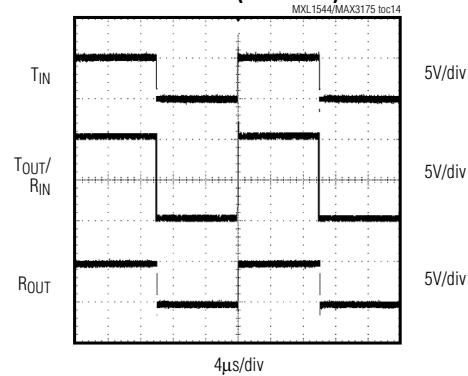

**MXL1544 LOOPBACK SCOPE PHOTO V.28 MODE (LOADED)**

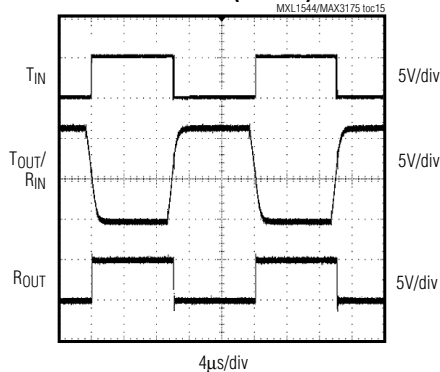

**MXL1544 LOOPBACK SCOPE PHOTO V.10 MODE (LOADED)**

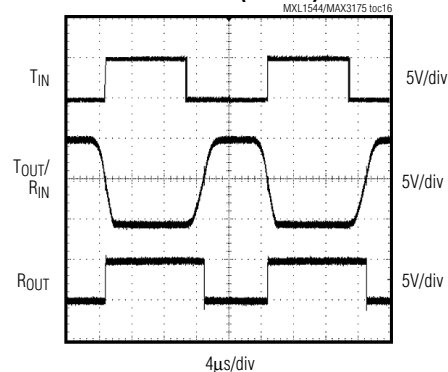

# **+5V Multiprotocol, Software-Selectable Control Transceivers**

## **Pin Description**

<b>PIN</b>	<b>NAME</b>	<b>FUNCTION</b>
1	V <sub>CC</sub>	+5V Supply Voltage (±5%). Bypass with a 1µF capacitor to ground.
2	V <sub>DD</sub>	Positive Supply Generated by MXL1543. Bypass with a 1µF capacitor to ground.
3	T1IN	Transmitter 1 TTL-Compatible Input
4	T2IN	Transmitter 2 TTL-Compatible Input
5	T3IN	Transmitter 3 TTL-Compatible Input
6	R1OUT	Receiver 1 CMOS Output
7	R2OUT	Receiver 2 CMOS Output
8	R3OUT	Receiver 3 CMOS Output
9	T4IN	Transmitter 4 TTL-Compatible Input
10	R4OUT	Receiver 4 CMOS Output
11	M0	TTL-Compatible Mode Select Pin with Internal Pullup to V <sub>CC</sub>
12	M1	TTL-Compatible Mode Select Pin with Internal Pullup to V <sub>CC</sub>
13	M2	TTL-Compatible Mode Select Pin with Internal Pullup to V <sub>CC</sub>
14	DCE/ $\overline{DTE}$	TTL-Compatible Input with Internal Pullup to V <sub>CC</sub> . Logic level high selects DCE interface.
15	INVERT	TTL Input with Internal Pullup to V <sub>CC</sub> . INVERT = HIGH reverses action of DCE/ $\overline{DTE}$ for Channel 4.
16	T4OUTA/R4INA	Transmitter Output/Inverting Receiver Input
17	R3INB	Noninverting Receiver Input
18	R3INA	Inverting Receiver Input
19	R2INB	Noninverting Receiver Input
20	R2INA	Inverting Receiver Input
21	T3OUTB/R1INB	Noninverting Transmitter Output/Noninverting Receiver Input
22	T3OUTA/R1INA	Inverting Transmitter Output/Inverting Receiver Input
23	T2OUTB	Noninverting Transmitter Output
24	T2OUTA	Inverting Transmitter Output
25	T1OUTB	Noninverting Transmitter Output
26	T1OUTA	Inverting Transmitter Output
27	GND	Ground
28	V <sub>EE</sub>	Negative Supply Generated by MXL1543. Bypass with a 1µF capacitor to ground.



# +5V Multiprotocol, Software-Selectable Control Transceivers

## Test Circuits

MXL1544/MAX3175

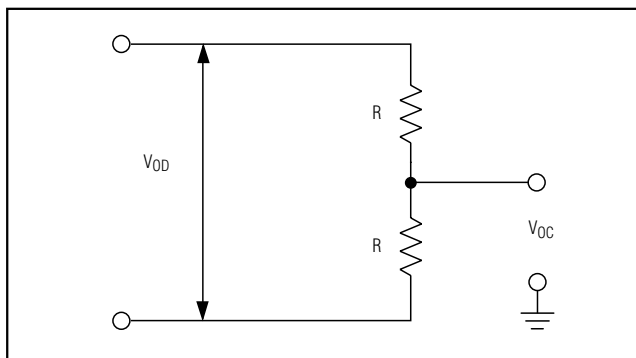

Figure 1. V.11 DC Test Circuit

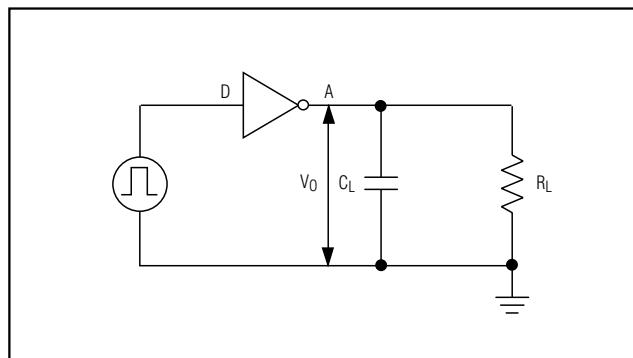

Figure 3. V.10/V.28 Driver Test Circuit

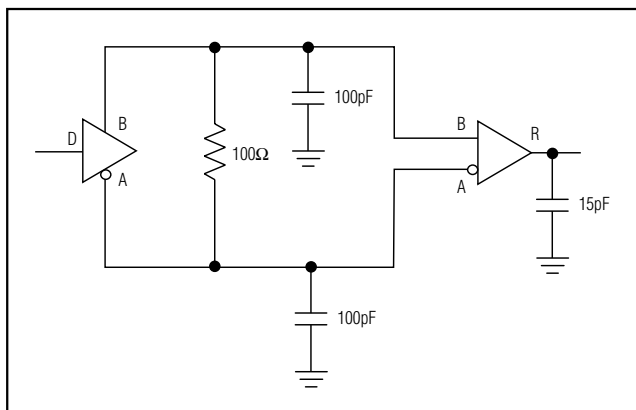

Figure 2. V.11 AC Test Circuit

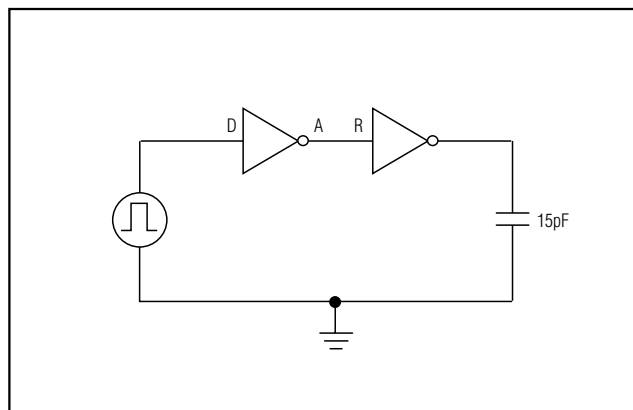

Figure 4. V.10/V.28 Receiver Test Circuit

### Detailed Description

The MXL1544/MAX3175 are four-driver/four-receiver multiprotocol transceivers that operate from a single +5V supply and the charge pump from the MXL1543. The MXL1544/MAX3175, along with the MXL1543 and MXL1344A, form a complete software-selectable DTE or DCE interface port that supports the V.28 (RS-232), V.10/V.11 (RS-449, V.36, EIA-530, EIA-530A, X.21, RS-423), and V.35 protocols. The MXL1544 or MAX3175 usually carries the control signals. The MXL1543 carries the high-speed clock and data signals, and the MXL1344A provides termination for the clock and data signals.

The MXL1544/MAX3175 feature a 0.5μA no-cable mode, true fail-safe operation, and thermal shutdown circuitry. Thermal shutdown protects the drivers against

excessive power dissipation. When activated, the thermal shutdown circuitry places the driver outputs into a high-impedance state. The MAX3175 deglitching feature reduces errors in unterminated equipment.

The state of the mode-select pins M0, M1, and M2 determines which serial-interface protocol is selected (Table 1). The state of the DCE/DTE input determines whether the transceivers will be configured as a DTE serial port or a DCE serial port. When the DCE/DTE input is logic HIGH, driver T3 is activated and receiver R1 is disabled. When the DCE/DTE input is logic LOW, driver T3 is disabled and receiver R1 is activated. The INVERT pin state changes the DCE/DTE functionality regarding T4 and R4 only. M0, M1, M2, INVERT, and DCE/DTE are internally pulled up to VCC to ensure logic HIGH if left unconnected.

# +5V Multiprotocol, Software-Selectable Control Transceivers

## Switching Time Waveforms

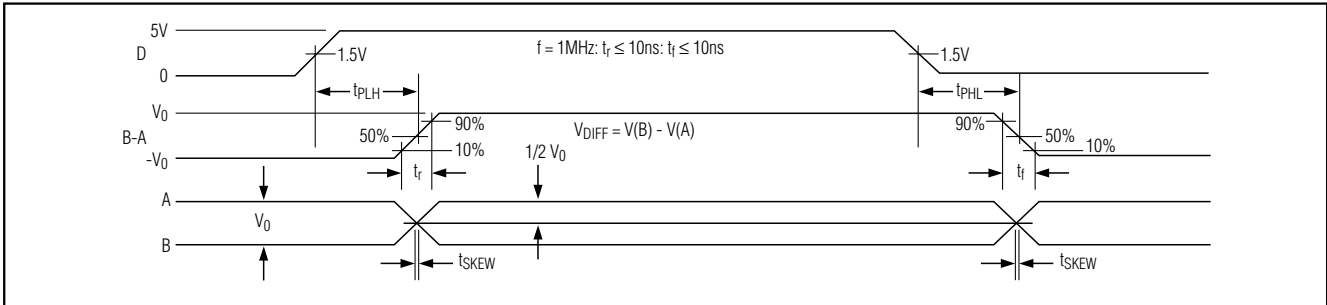

Figure 5. V.11, V.35 Driver Propagation Delays

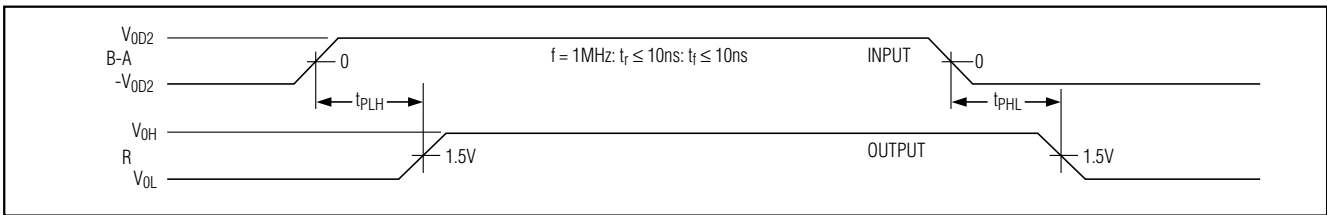

Figure 6. V.11, V.35 Receiver Propagation Delays

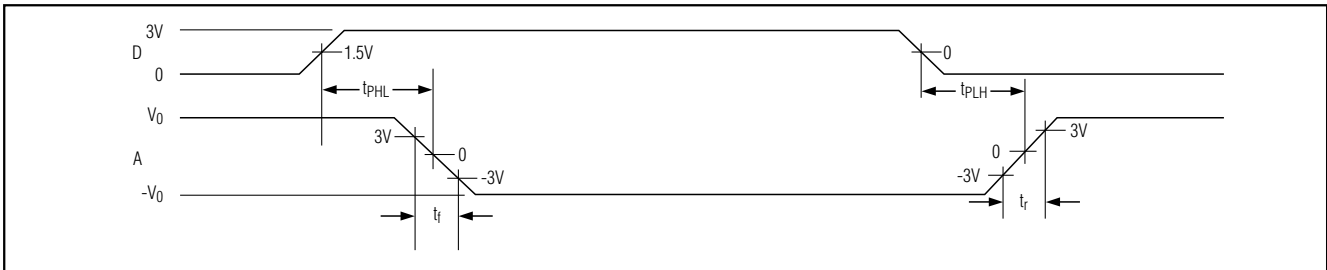

Figure 7. V.10, V.28 Driver Propagation Delays

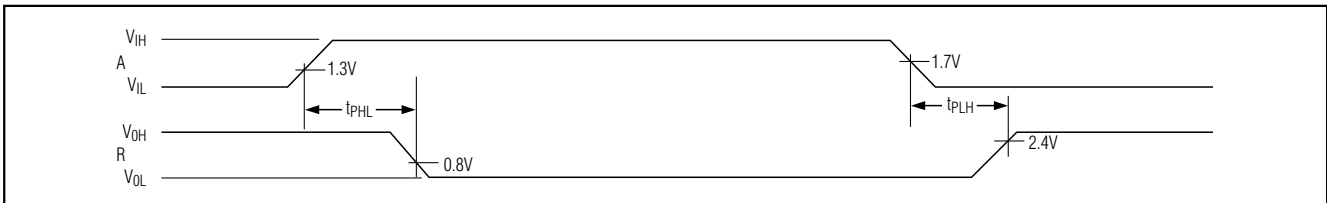

Figure 8. V.10, V.28 Receiver Propagation Delays

# +5V Multiprotocol, Software-Selectable Control Transceivers

The MXL1544/MAX3175s' mode can be selected through software control of the M0, M1, M2, INVERT, and DCE/DTE inputs. Alternatively, the mode can be selected by shorting the appropriate combination of mode control inputs to GND (the inputs left floating will be internally pulled up to  $V_{CC}$  - logic HIGH). If the M0, M1, and M2 mode inputs are all unconnected, the MXL1544/MAX3175 will enter no-cable mode.

## Fail-Safe

The MXL1544/MAX3175 guarantee a logic HIGH receiver output when the receiver inputs are shorted or open, or when they are connected to a terminated transmission line with all drivers disabled. The V.11 receiver threshold is set between -200mV and 0mV to guarantee fail-safe operation. If the differential receiver input voltage ( $B - A$ ) is  $\geq 0$ mV, ROUT is logic HIGH. In the case of a terminated bus with all transmitters disabled, the receiver's differential input voltage is pulled to 0 by the termination. With the receiver thresholds of the MXL1544/MAX3175, this results in ROUT logic HIGH.

The V.10 receiver threshold is set between -250mV and 0mV. If the V.10 receiver input voltage is less than or equal to -250mV, ROUT is logic HIGH. The V.28 receiver threshold is set between 0.8V and 2.0V. If the receiver input voltage is less than or equal to 0.8V, ROUT is logic HIGH. In the case of a terminated bus with transmitters disabled, the receiver's input voltage is pulled to 0 by the termination.

## Applications Information

### Cable-Selectable Mode

A cable-selectable, multiprotocol DTE/DCE interface is shown in Figure 9. The mode control lines M0, M1, and DCE/DTE are wired to the DB-25 connector. To select the serial interface mode, the appropriate combination of M0, M1, M2, and DCE/DTE are grounded within the cable wiring. The control lines that are not grounded are pulled high by the internal pullups on the MXL1543. The serial interface protocol of the MXL1544/MAX3175 is now selected based on the cable that is connected to the DB-25 interface.

### V.10 (RS-423) Interface

The V.10 interface (Figure 10) is an unbalanced single-ended interface capable of driving a 450 $\Omega$  load. The V.10 driver generates a minimum  $V_O$  voltage of  $\pm 4$ V across A' and C' when unloaded and a minimum voltage of  $0.9 \times V_O$  when loaded with 450 $\Omega$ . The V.10 receiver has a single-ended input and does not reject common-mode differences between C and C'. The V.10 receiver input trip threshold is defined between

+250mV and -250mV with input impedance characteristic shown in Figure 11.

The MXL1544/MAX3175 V.10 mode receiver has a differential threshold between -250mV and +250mV. To ensure that the receiver has proper fail-safe operation see the *Fail-Safe* section. To aid in rejecting system noise, the MXL1544/MAX3175 V.10 receiver has a typical hysteresis of 25mV. Switch S3 in Figure 12 is open in V.10 mode to disable the V.28 5k $\Omega$  termination at the receiver input. Switch S4 is closed and switch S5 is open to internally ground the receiver B input.

### V.11 (RS-422) Interface

As shown in Figure 13, the V.11 protocol is a fully balanced differential interface. The V.11 driver generates a minimum of  $\pm 2$ V between nodes A and B when 100 $\Omega$  minimum resistance is presented at the load. The V.11 receiver is sensitive to differential signals of  $\pm 200$ mV at receiver inputs A' and B'. The V.11 receiver input must comply with the impedance curve of Figure 11 and reject common-mode signals developed across the cable (referenced from C to C' in Figure 13) of up to  $\pm 7$ V.

The MXL1544/MAX3175 V.11 mode receiver has a differential threshold between -200mV and +200mV. To ensure that the receiver has proper fail-safe operation; see the *Fail-Safe* section. To aid in rejecting system noise, the MXL1544/MAX3175 V.11 receiver has a typical hysteresis of 15mV. Switch S3 in Figure 14 is open in V.11 mode to disable the V.28 5k $\Omega$  termination at the inverting receiver input. Because the control signals are slow (60kbps), 100 $\Omega$  termination resistance is generally not required for the MXL1544/MAX3175. The receiver inputs must also be compliant with the impedance curve shown in Figure 11.

### V.28 (RS-232) Interface

The V.28 interface is an unbalanced single-ended interface (Figure 10). The V.28 generator provides a minimum of  $\pm 5$ V across the 3k $\Omega$  load impedance between A' and C'. The V.28 receiver has single-ended input.

The MXL1544/MAX3175 V.28 mode receiver has a threshold between +0.8V and +2.0V. To aid in rejecting system noise, the MXL1544/MAX3175 V.28 receiver has a typical hysteresis of 50mV. Switch S3 in Figure 15 is closed in V.28 mode to enable the 5k $\Omega$  V.28 termination at the receiver inputs.

### No-Cable Mode

The MXL1544/MAX3175 will enter no-cable mode when the mode-select pins are left unconnected or connected HIGH (M0 = M1 = M2 = 1). In this mode, the multiprotocol drivers and receivers are disabled and the

# +5V Multiprotocol, Software-Selectable Control Transceivers

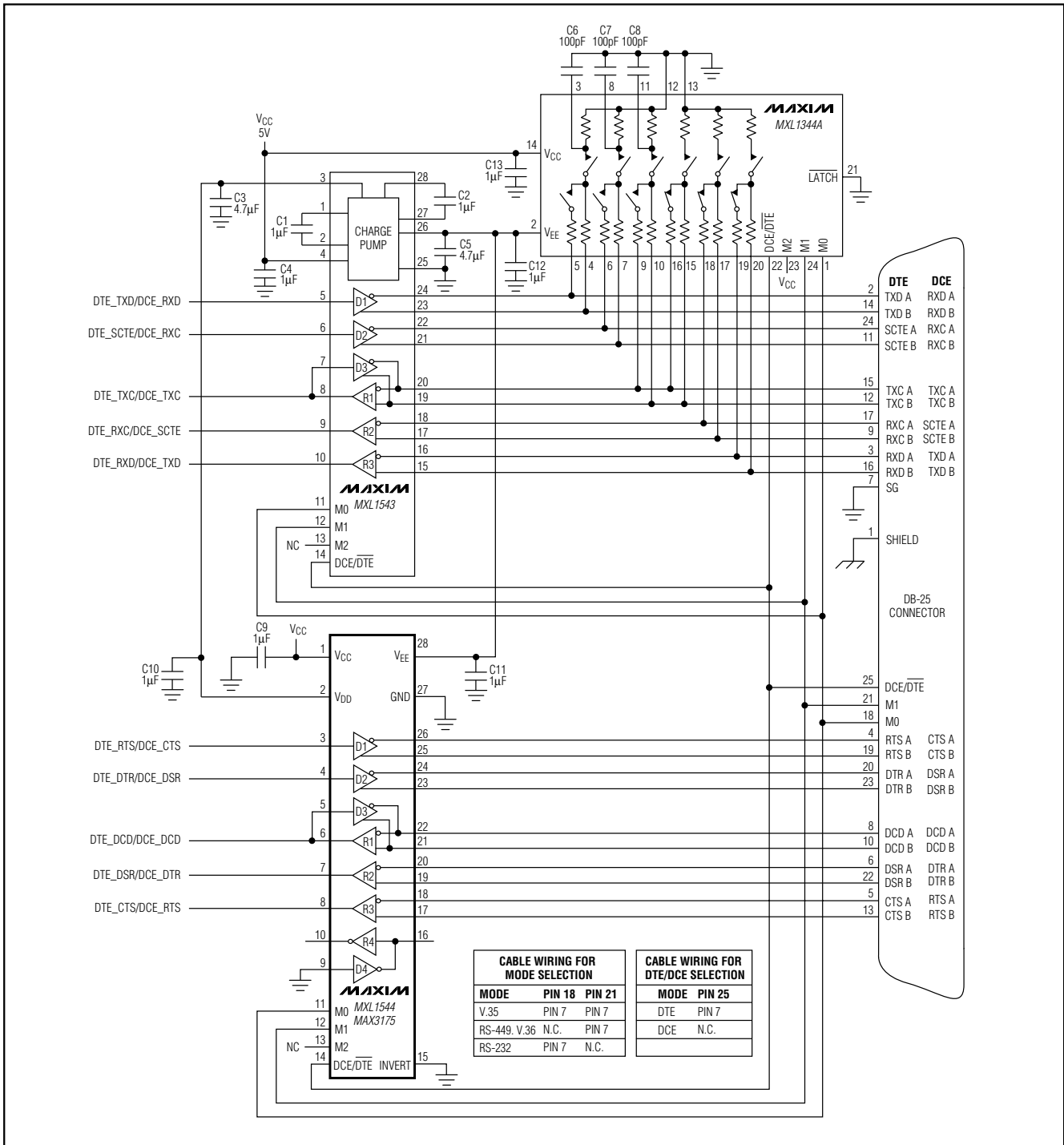

Figure 9. Cable-Selectable Multiprotocol DCE/DTE Port with DB-25 Connector

# +5V Multiprotocol, Software-Selectable Control Transceivers

MXL1544/MAX3175

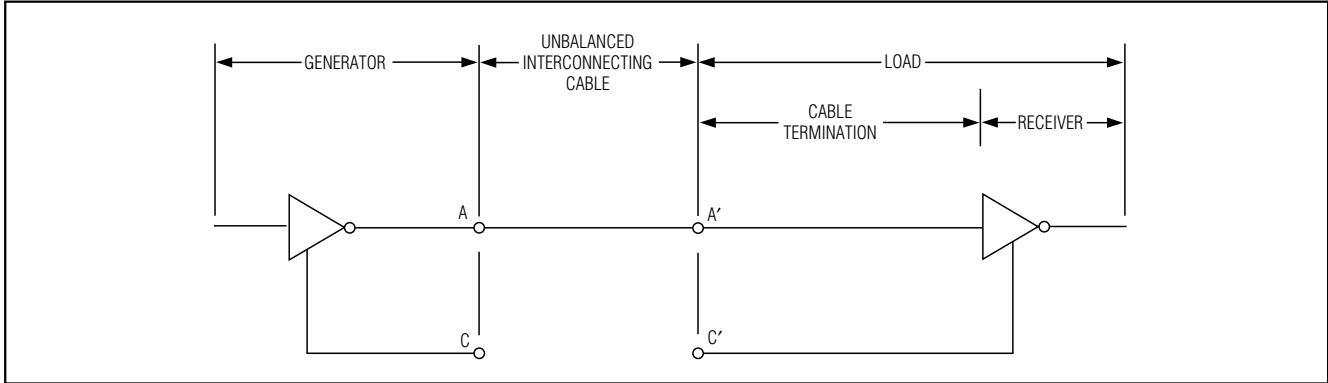

Figure 10. Typical V.10/V.28 Interface

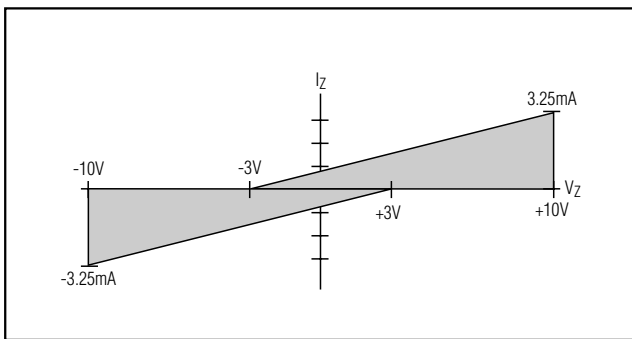

Figure 11. Receiver Input Impedance Curve

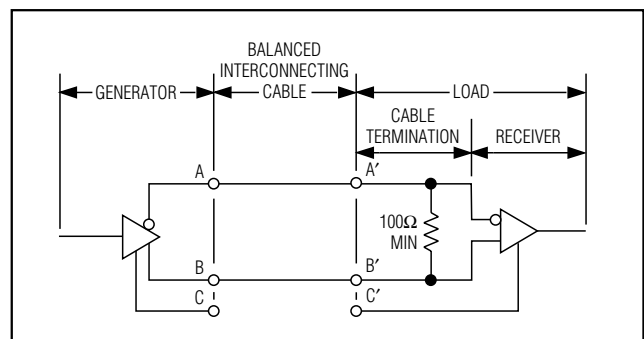

Figure 13. Typical V.11 Interface

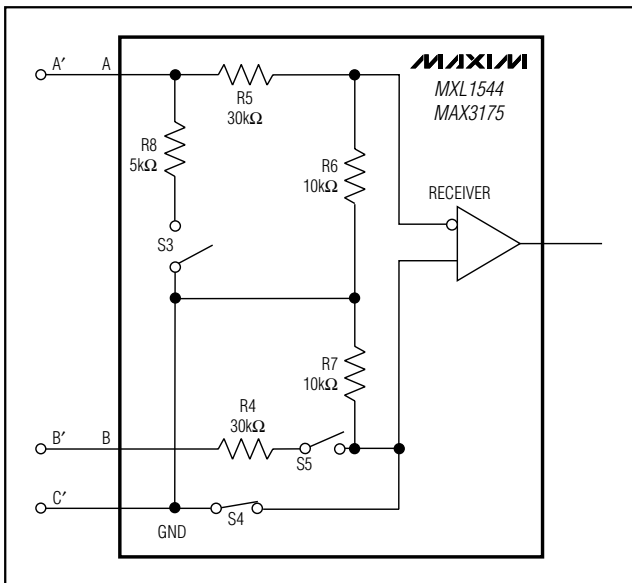

Figure 12. V.10 Internal Resistance Network

supply current is less than  $10\mu\text{A}$ . The receiver outputs enter a high-impedance state in no-cable mode, which allows these output lines to be shared with other receiver outputs (the receiver outputs have an internal pullup resistor to pull the outputs HIGH if not driven). Also, in no-cable mode, the transmitter outputs enter a high-impedance state, so these output lines can be shared with other devices.

### Receiver Glitch Rejection

To improve operation in an unterminated or otherwise noisy system, the MAX3175 features  $10\mu\text{s}$  of receiver input glitch rejection. The glitch-rejection circuitry blocks the reception of high-frequency noise ( $t_B < 5\mu\text{s}$ ) while receiving a low-frequency signal ( $t_B > 15\mu\text{s}$ ) allowing glitch-free operation in unterminated systems at up to 60kbps. The MXL1544 does not have this feature and can be operated at frequencies greater than 60kbps if properly terminated.

# +5V Multiprotocol, Software-Selectable Control Transceivers

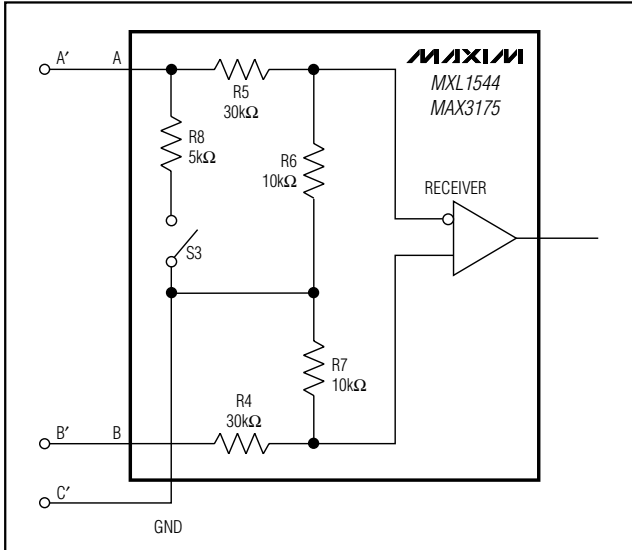

Figure 14. V.11 Internal Resistance Networks

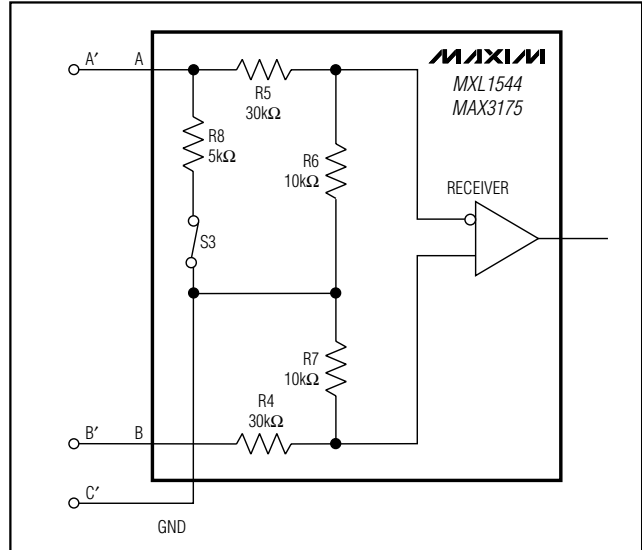

Figure 15. V.28 Termination and Internal Resistance Network

### DTE vs. DCE Operation

Figure 16 shows a port with one DB-25 connector that can be configured for either DTE or DCE operation. The configuration requires separate cables for proper signal routing in DTE or DCE operation. Figure 16 illustrates a DCE or DTE controller-selectable interface. The DCE/DTE and INVERT inputs switch the port's mode of operation (Table 1).

The MXL1543 and MXL1544/MAX3175 can be connected for either DTE or DCE operation in one of two ways: a dedicated DTE or DCE port with an appropriate gender connector or a port with a connector that can be configured for DTE or DCE operation by rerouting the signals to the MXL1543 and MXL1544/MAX3175 using

a dedicated DTE cable or dedicated DCE cable. The interface mode is selected by logic outputs from the controller or from jumpers to either  $V_{CC}$  or GND on the mode select pins. A dedicated DCE port using a DB-25 female connector is shown in Figure 17. Figure 18 illustrates a dedicated DTE port using a DB-25 male connector.

# +5V Multiprotocol, Software-Selectable Control Transceivers

**MXL1544/MAX3175**

**Table 1. Mode Select Table**

PROTOCOL	M2	M1	M0	DCE/ DTE	INVERT	T1	T2	T3	R1	R2	R3	T4	R4
Not Used (Default V.11)	0	0	0	0	0	V.11	V.11	Z	V.11	V.11	V.11	Z	V.10
RS-530A	0	0	1	0	0	V.11	V.10	Z	V.11	V.10	V.11	Z	V.10
RS-530	0	1	0	0	0	V.11	V.11	Z	V.11	V.11	V.11	Z	V.10
X.21	0	1	1	0	0	V.11	V.11	Z	V.11	V.11	V.11	Z	V.10
V.35	1	0	0	0	0	V.28	V.28	Z	V.28	V.28	V.28	Z	V.28
RS-449/V.36	1	0	1	0	0	V.11	V.11	Z	V.11	V.11	V.11	Z	V.10
V.28/RS-232	1	1	0	0	0	V.28	V.28	Z	V.28	V.28	V.28	Z	V.28
No Cable	1	1	1	0	0	Z	Z	Z	Z	Z	Z	Z	Z
Not Used (Default V.11)	0	0	0	0	1	V.11	V.11	Z	V.11	V.11	V.11	V.10	Z
RS-530A	0	0	1	0	1	V.11	V.10	Z	V.11	V.10	V.11	V.10	Z
RS-530	0	1	0	0	1	V.11	V.11	Z	V.11	V.11	V.11	V.10	Z
X.21	0	1	1	0	1	V.11	V.11	Z	V.11	V.11	V.11	V.10	Z
V.35	1	0	0	0	1	V.28	V.28	Z	V.28	V.28	V.28	V.28	Z
RS-449/V.36	1	0	1	0	1	V.11	V.11	Z	V.11	V.11	V.11	V.10	Z
V.28/RS-232	1	1	0	0	1	V.28	V.28	Z	V.28	V.28	V.28	V.28	Z
No Cable	1	1	1	0	1	Z	Z	Z	Z	Z	Z	Z	Z
Not Used (Default V.11)	0	0	0	1	0	V.11	V.11	V.11	Z	V.11	V.11	V.10	Z
RS-530A	0	0	1	1	0	V.11	V.10	V.11	Z	V.10	V.11	V.10	Z
RS-530	0	1	0	1	0	V.11	V.11	V.11	Z	V.11	V.11	V.10	Z
X.21	0	1	1	1	0	V.11	V.11	V.11	Z	V.11	V.11	V.10	Z
V.35	1	0	0	1	0	V.28	V.28	V.28	Z	V.28	V.28	V.28	Z
RS-449/V.36	1	0	1	1	0	V.11	V.11	V.11	Z	V.11	V.11	V.10	Z
V.28/RS-232	1	1	0	1	0	V.28	V.28	V.28	Z	V.28	V.28	V.28	Z
No Cable	1	1	1	1	0	Z	Z	Z	Z	Z	Z	Z	Z
Not Used (Default V.11)	0	0	0	1	1	V.11	V.11	V.11	Z	V.11	V.11	Z	V.10
RS-530A	0	0	1	1	1	V.11	V.10	V.11	Z	V.10	V.11	Z	V.10
RS-530	0	1	0	1	1	V.11	V.11	V.11	Z	V.11	V.11	Z	V.10
X.21	0	1	1	1	1	V.11	V.11	V.11	Z	V.11	V.11	Z	V.10
V.35	1	0	0	1	1	V.28	V.28	V.28	Z	V.28	V.28	Z	V.28
RS-449/V.36	1	0	1	1	1	V.11	V.11	V.11	Z	V.11	V.11	Z	V.10
V.28/RS-232	1	1	0	1	1	V.28	V.28	V.28	Z	V.28	V.28	Z	V.28
No Cable	1	1	1	1	1	Z	Z	Z	Z	Z	Z	Z	Z

# +5V Multiprotocol, Software-Selectable Control Transceivers

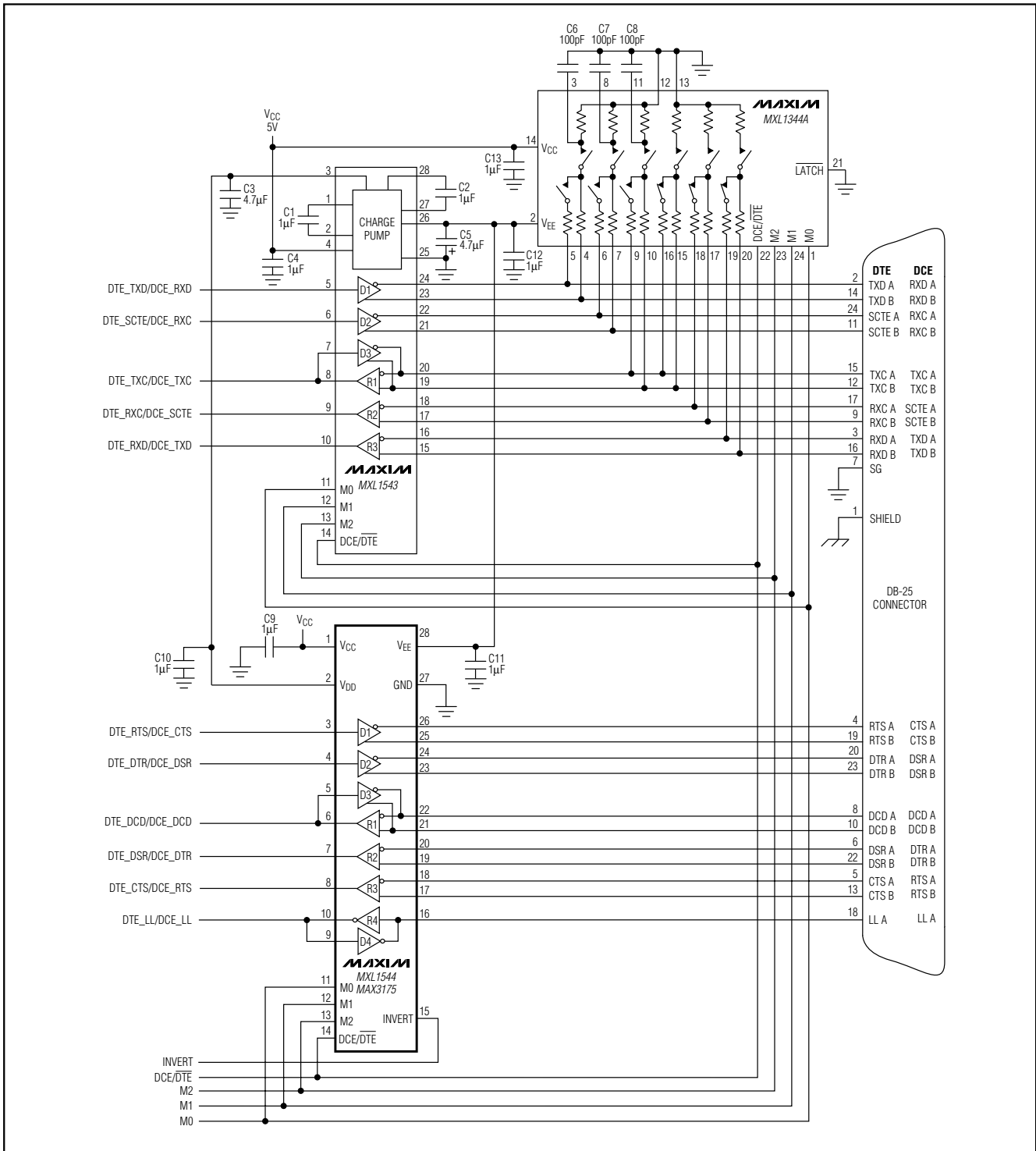

Figure 16. Controller-Selectable Multiprotocol DCE/DTE Port with DB-25 Connector



# +5V Multiprotocol, Software-Selectable Control Transceivers

**MXL1544/MAX3175**

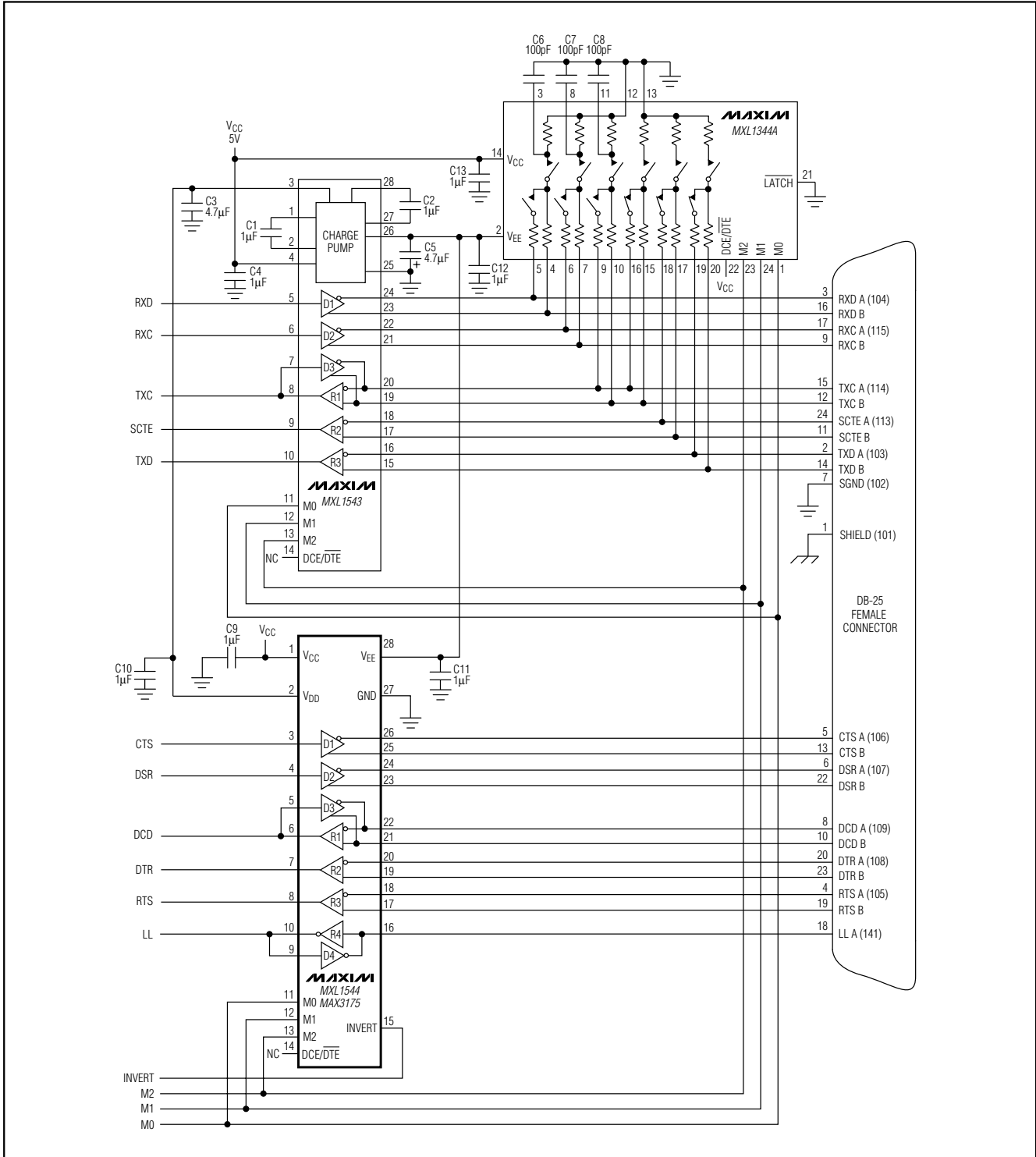

Figure 17. Controller-Selectable DCE Port with DB-25 Connector

# +5V Multiprotocol, Software-Selectable Control Transceivers

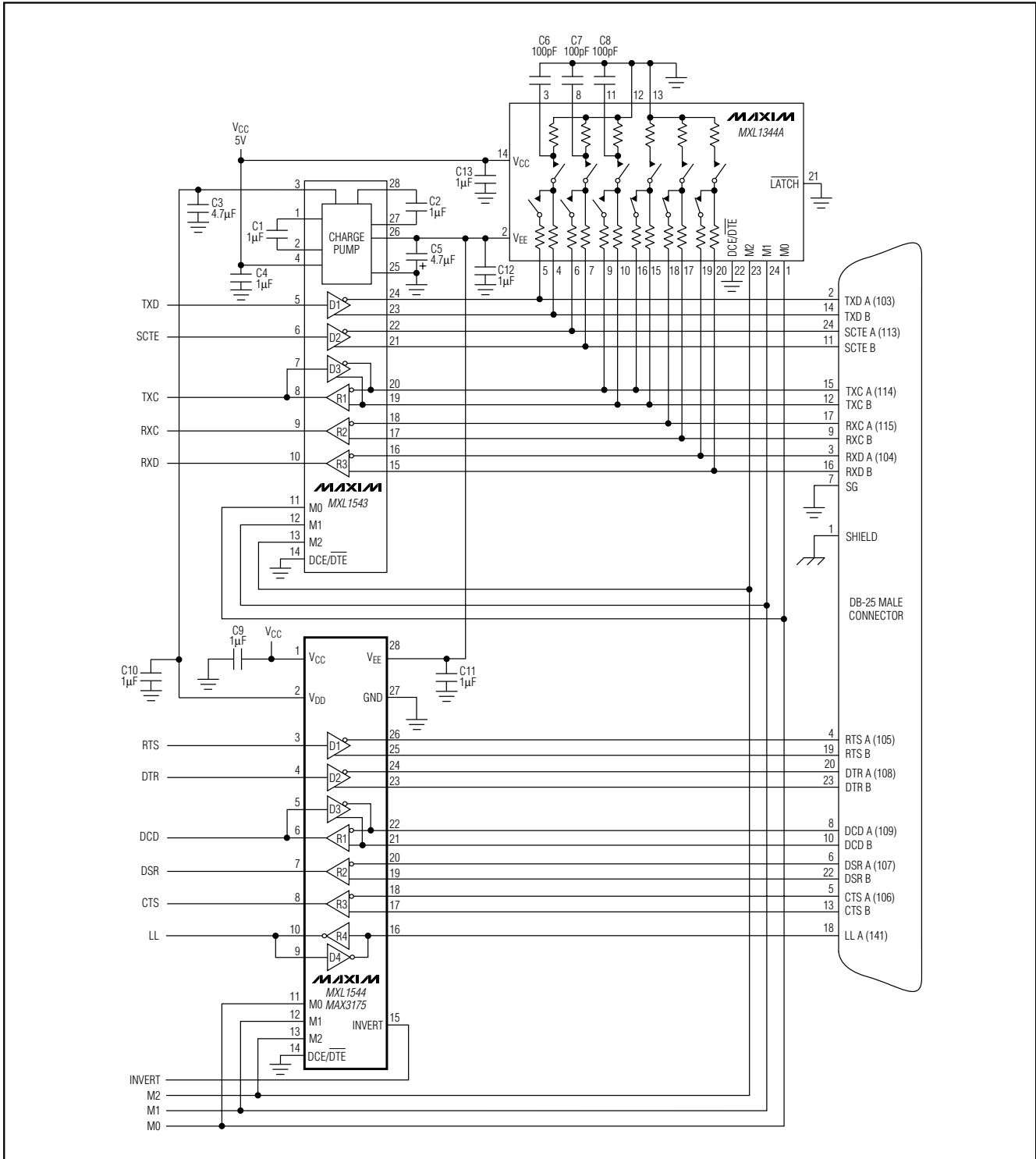

Figure 18. Controller-Selectable Multiprotocol DTE Port with DB-25 Connector

# +5V Multiprotocol, Software-Selectable Control Transceivers

## Chip Information

TRANSISTOR COUNT: 2348

PROCESS: BiCMOS

## Pin Configuration

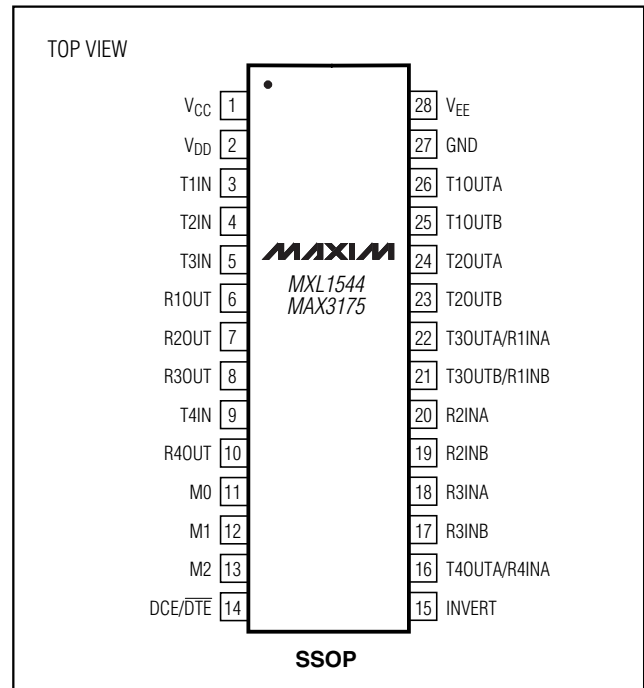

**MXL1544/MAX3175**

# **+5V Multiprotocol, Software-Selectable Control Transceivers**

## **Package Information**

DIM	INCHES		MILLIMETERS	
	MIN	MAX	MIN	MAX
A	0.068	0.078	1.73	1.99
A1	0.002	0.008	0.05	0.21
B	0.010	0.015	0.25	0.38
C	0.004	0.008	0.09	0.20
D	SEE VARIATIONS			
E	0.205	0.209	5.20	5.38
e	0.0256 BSC		0.65 BSC	
H	0.301	0.311	7.65	7.90
L	0.025	0.037	0.63	0.95
$\alpha$	0°	8°	0°	8°

D	INCHES		MILLIMETERS		N
	MIN	MAX	MIN	MAX	
D	0.239	0.249	6.07	6.33	14L
D	0.239	0.249	6.07	6.33	16L
D	0.278	0.289	7.07	7.33	20L
D	0.317	0.328	8.07	8.33	24L
D	0.397	0.407	10.07	10.33	28L

NOTES:  
 1. D&E DO NOT INCLUDE MOLD FLASH.  
 2. MOLD FLASH OR PROTRUSIONS NOT TO EXCEED .15mm (.006").  
 3. CONTROLLING DIMENSION: MILLIMETERS.  
 4. MEETS JEDEC MO150.

<b>MAXIM</b>		
<small>PROPRIETARY INFORMATION</small>		
<small>TITLE:</small>		
PACKAGE OUTLINE, SSOP, 5.3x.65mm		
<small>APPROVAL</small>	<small>DOCUMENT CONTROL NO.</small>	<small>REV</small>
	21-0056	B 1/1

SSOP:EPS

Maxim cannot assume responsibility for use of any circuitry other than circuitry entirely embodied in a Maxim product. No circuit patent licenses are implied. Maxim reserves the right to change the circuitry and specifications without notice at any time.

20 \_\_\_\_\_ **Maxim Integrated Products, 120 San Gabriel Drive, Sunnyvale, CA 94086 408-737-7600**