

- 1
- 2
- 3
- 4
- 5
- 6
- 7
- 8
- 9
- 10
- 11
- 12
- 13
- 14
- 15
- 16
- 17
- 18

BASE

Glass-fibre reinforced polyamide based (PA) technopolymer, black colour, matte finish.

STANDARD EXECUTIONS

AISI 304 stainless steel articulated and threaded stem with adjusting square.

- **LVQ.FO-SST**: base without no-slip disk.
- **LVQ.FO-AS-SST**: base with NBR rubber no-slip disk, hardness 70 Shore A, supplied assembled to the base.

GROUND MOUNTING

By means of two holes, supplied covered by a diaphragm (which can be easily removed by a metal tool), to avoid all unhealthy deposits of dirt and dust when only one hole is used (see Fig. 1).

FEATURES

The special knurling under the lower lip of the base provides excellent stability and grip when using the levelling element without no-slip disk even on surfaces that are not perfectly flat.

The particular assembling system of the no-slip disk to the base assures a perfect anchoring, preventing separation even in case of impact during transport or of adhesion (sticking) to the floor (see No-slip disks on page 1283).

ORDER INFORMATION

The levelling elements are supplied unassembled to make carriage and storage easier. The components (base and stem) are supplied in separate packing: less volume taken and better protection from scratches and dirt.

To order bases and stems separately, see:

- table of possible combinations Bases/Stems (see page 1292)
- the codes of the Bases (see page 1288)
- the codes of the Stems (see page 1290).

ACCESSORIES ON REQUEST

AISI 304 stainless steel nut (see Nuts NT. on page 1283).



ELESA Original design

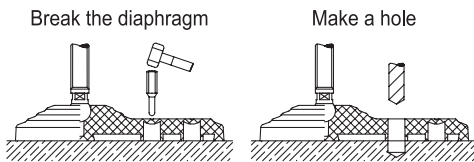
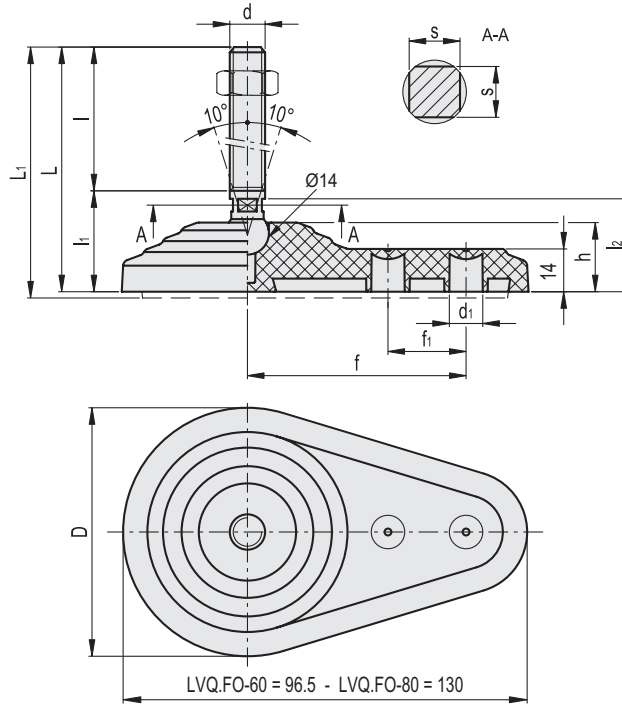

Fig.1



Conversion Table	
1 mm = 0.039 inch	
D	
mm	inch
60	2.36
80	3.15

LVQ.FO-SST

LVQ.FO-AS-SST

INOX STAINLESS STEEL METRIC

Code	Description	Code	Description	D	d	d1	L	L1#	l	li	l2	h	f	fi	s	Max. limit stati load* [N]	⚖️	⚖️#
533901	LVQ.FO-60-14-SST-M16x68	536901	LVQ.FO-60-14-AS-SST-M16x68	60	M16	8.5	99	101	68	31	29.5	21	50	18	12	14000	144	160
533906	LVQ.FO-60-14-SST-M16x108	536906	LVQ.FO-60-14-AS-SST-M16x108	60	M16	8.5	139	141	108	31	29.5	21	50	18	12	14000	208	224
533911	LVQ.FO-60-14-SST-M16x148	536911	LVQ.FO-60-14-AS-SST-M16x148	60	M16	8.5	179	181	148	31	29.5	21	50	18	12	14000	272	288
533916	LVQ.FO-60-14-SST-M16x168	536916	LVQ.FO-60-14-AS-SST-M16x168	60	M16	8.5	199	201	168	31	29.5	21	50	18	12	14000	304	320
533921	LVQ.FO-60-14-SST-M20x110	536921	LVQ.FO-60-14-AS-SST-M20x110	60	M20	8.5	146	148	110	36	33.5	21	50	18	15	14000	308	324
533926	LVQ.FO-60-14-SST-M20x150	536926	LVQ.FO-60-14-AS-SST-M20x150	60	M20	8.5	186	188	150	36	33.5	21	50	18	15	14000	408	424
533931	LVQ.FO-60-14-SST-M20x170	536931	LVQ.FO-60-14-AS-SST-M20x170	60	M20	8.5	206	208	170	36	33.5	21	50	18	15	14000	458	474
533936	LVQ.FO-60-14-SST-M20x210	536936	LVQ.FO-60-14-AS-SST-M20x210	60	M20	8.5	246	248	210	36	33.5	21	50	18	15	14000	557	573
533941	LVQ.FO-60-14-SST-M24x110	536941	LVQ.FO-60-14-AS-SST-M24x110	60	M24	8.5	146	148	110	36	33.5	21	50	18	18	14000	415	431
533946	LVQ.FO-60-14-SST-M24x170	536946	LVQ.FO-60-14-AS-SST-M24x170	60	M24	8.5	206	208	170	36	33.5	21	50	18	18	14000	630	646
533951	LVQ.FO-60-14-SST-M24x210	536951	LVQ.FO-60-14-AS-SST-M24x210	60	M24	8.5	246	248	210	36	33.5	21	50	18	18	14000	774	790
534001	LVQ.FO-80-14-SST-M16x68	537001	LVQ.FO-80-14-AS-SST-M16x68	80	M16	10.5	100	102	68	32	30.5	22	70	25	12	16000	182	212
534003	LVQ.FO-80-14-SST-M16x108	537003	LVQ.FO-80-14-AS-SST-M16x108	80	M16	10.5	140	142	108	32	30.5	22	70	25	12	16000	246	276
534005	LVQ.FO-80-14-SST-M16x148	537005	LVQ.FO-80-14-AS-SST-M16x148	80	M16	10.5	180	182	148	32	30.5	22	70	25	12	16000	310	340
534007	LVQ.FO-80-14-SST-M16x168	537007	LVQ.FO-80-14-AS-SST-M16x168	80	M16	10.5	200	202	168	32	30.5	22	70	25	12	16000	342	372
534011	LVQ.FO-80-14-SST-M20x110	537011	LVQ.FO-80-14-AS-SST-M20x110	80	M20	10.5	147	149	110	37	34.5	22	70	25	15	16000	346	376
534013	LVQ.FO-80-14-SST-M20x150	537013	LVQ.FO-80-14-AS-SST-M20x150	80	M20	10.5	187	189	150	37	34.5	22	70	25	15	16000	446	476
534015	LVQ.FO-80-14-SST-M20x170	537015	LVQ.FO-80-14-AS-SST-M20x170	80	M20	10.5	207	209	170	37	34.5	22	70	25	15	16000	496	526
534017	LVQ.FO-80-14-SST-M20x210	537017	LVQ.FO-80-14-AS-SST-M20x210	80	M20	10.5	247	249	210	37	34.5	22	70	25	15	16000	595	625
534021	LVQ.FO-80-14-SST-M24x110	537021	LVQ.FO-80-14-AS-SST-M24x110	80	M24	10.5	147	149	110	37	34.5	22	70	25	18	16000	453	483
534023	LVQ.FO-80-14-SST-M24x170	537023	LVQ.FO-80-14-AS-SST-M24x170	80	M24	10.5	207	209	170	37	34.5	22	70	25	18	16000	668	698
534025	LVQ.FO-80-14-SST-M24x210	537025	LVQ.FO-80-14-AS-SST-M24x210	80	M24	10.5	247	249	210	37	34.5	22	70	25	18	16000	812	842

* The max static load is the value above which the load applied to the element may cause some plastic material breakage, in particular conditions of use. Obviously, a factor that takes into consideration the importance and the safety level of the specific application must be applied to this value.

Data with no-slip disk mounted.

