

## DESCRIPTION

Demonstration circuit 945 is an I/Q modulator featuring the LT<sup>®</sup>5572. The LT<sup>®</sup>5572 is a 1.5GHz to 2.5GHz direct I/Q modulator designed for high performance wireless applications, including wireless infrastructure. It may also be configured as an image reject upconverting mixer, by applying 90° phase-shifted signals to the I and Q inputs.

A high-speed, internally matched LO amplifier drives two double-balanced mixer cores, allowing the use of a low power, single-ended LO source. It allows direct modulation of an RF signal using differential baseband I and Q signals. The LT<sup>®</sup>5572 supports GSM, EDGE, CDMA, CDMA2000, W-CDMA, 64-QAM, OFDM and other modulation formats.

The I/Q baseband inputs consist of voltage-to-current converters that in turn drive double-balanced mixers. The outputs of these mixers are summed and applied to an on-chip RF transformer, which converts the differential mixer signals to a 50Ω single-ended

output. The four balanced I and Q base-band input ports are intended for DC coupling from a source with a common-mode voltage level of about 0.5V. The differential input impedance of the baseband inputs is approximately 90KΩ. The input termination impedance is easily set for a specific application using external resistors. On the DC945 demonstration circuit, this is set to 100Ω differential, making it ideally suited for current drive applications.

The LO path consists of an LO buffer with single-ended input, and precision quadrature generators which produce the LO drive for the mixers.

Demonstration circuit 945 is designed for an RF output frequency range from 1.5GHz to 2.5GHz.

**Design files for this circuit board are available. Call the LTC factory.**

---

LT is a registered trademark of Linear Technology Corporation.

# QUICK START GUIDE FOR DEMONSTRATION CIRCUIT 945

## HIGH LINEARITY DIRECT QUADRATURE MODULATOR

**Table 1. Typical Performance Summary ( $T_A = 25^\circ\text{C}$ )**

PARAMETER	CONDITION ( $f_{\text{RF}} = 2\text{MHz}$ , $f_{\text{LO}} = 2000\text{MHz}$ )	VALUE
Supply Voltage		4.5V to 5.25V
Supply Current	$V_{\text{CC}} = 5\text{V}$ , EN = High	120 mA
Maximum Shutdown Current	$V_{\text{CC}} = 5\text{V}$ , EN = Low	230 $\mu\text{A}$
RF Frequency Range		1.5 to 2.5 GHz
Baseband Frequency Range		DC to 460 MHz
LO Input Return Loss	$Z_0 = 50\Omega$ , $P_{\text{LO}} = 0\text{dBm}$	15 dB
RF Output Return Loss	$Z_0 = 50\Omega$	13.5 dB
LO Input Power		-10 to +5 dBm
LO Frequency Range		1.5 to 2.5 GHz
Conversion Gain	$P_{\text{RF}} = -10\text{dBm}$ , $P_{\text{LO}} = 0\text{dBm}$ , defined as $P_{\text{RF}}/P_{\text{BB}}$	-2.5dB
Output 3 <sup>rd</sup> Order Intercept	2-Tone, $P_{\text{RF}} = -10\text{dBm/Tone}$ , $\Delta f = 100\text{KHz}$ , $P_{\text{LO}} = 0\text{dBm}$	+21.6dBm
Output 2 <sup>nd</sup> Order Intercept	2-Tone, $P_{\text{RF}} = -10\text{dBm/Tone}$ , $\Delta f = 100\text{KHz}$ , $P_{\text{LO}} = 0\text{dBm}$	+53.2 dBm
Output 1dB Compression	$P_{\text{LO}} = 0\text{dBm}$	+9.3 dBm
LO leakage	$P_{\text{LO}} = 0\text{dBm}$	-39.4 dBm
Image Rejection	$P_{\text{LO}} = 0\text{dBm}$	-41.2 dBc

### APPLICATION NOTE

#### RF FREQUENCY RANGE

No tuning is required for operation over the RF frequency range of 1.5 GHz to 2.5 GHz.

#### BASEBAND FREQUENCY RANGE

The baseband frequency range extends from DC to 460 MHz (3dB bandwidth).

#### LO TO RF LEAKAGE

The LT<sup>®</sup>5572 offers excellent LO to RF leakage performance, typically -39.4 dBm.

### TEST EQUIPMENT AND SETUP

Refer to Figure 1 for proper measurement equipment setup. Before performing measurements on the DUT, it is very important to evaluate the test system performance to ensure that: 1) distortion-free input signals are applied and 2) the spectrum analyzer internal distortion is minimized. Follow the guidelines below to do this.

Use high performance signal generators with low harmonic output (>75 dBc) for 2-tone measurements. The signal generators must provide 2 equal amplitude outputs in quadrature with one another. High quality combiners that provide broadband 50 ohm termination on all ports should be used. The combiners should have good port-to-port isolation (>30 dB) to prevent the signal generators from modulating each other and generating intermodulation products. Attenuators on the outputs of these generators can also be used to increase the effective port-to-port isolation.

The LO leakage may be further reduced by the introduction of small differential DC offsets ( $V_{\text{BBIP}} - V_{\text{BBIM}}$ ,  $V_{\text{BBQP}} - V_{\text{BBQM}}$ ) at the

baseband inputs, typically less than 10mV. These DC offsets may be introduced by applying slightly different DC bias voltages to each of the four 10K $\Omega$  resistors shown in Figure 1.

#### SIDETONE TO RF LEAKAGE

The LT<sup>®</sup>5572 also offers very good image rejection (sidetone suppression) at the RF port. The image rejection may be further enhanced by the introduction of small differential phase and amplitude offsets at the baseband inputs.

Spectrum analyzers can produce significant internal distortion products if they are overdriven. Sufficient spectrum analyzer input attenuation should be used to avoid saturating the instrument. A typical input 3<sup>rd</sup> order intercept point for a spectrum analyzer is +40 dBm, with 20 dB input attenuation applied. This is more than 10 dB above the intercept point of the DUT, and should yield accurate 3<sup>rd</sup> order distortion results.

# QUICK START GUIDE FOR DEMONSTRATION CIRCUIT 945

## HIGH LINEARITY DIRECT QUADRATURE MODULATOR

---

### QUICK START PROCEDURE

Demonstration circuit 945 is easy to set up to evaluate the performance of the LT<sup>®</sup>5572. Refer to Figure 1 for proper measurement equipment setup.

Follow the procedure below:

1. Connect all test equipment as shown in Figure 1.
2. Set the DC power supply's current limit to 150mA, and adjust output voltage to 5V.
3. Connect Vcc to the 5V DC supply, and then connect VCCEN to 5V; the modulator is enabled (on).
4. Set the baseband bias supply's output voltage to 0.5V.
5. Set Signal Generator #1 to provide a 2000MHz, 0dBm, CW signal to the demo board LO input port.
6. Set the Signal Generators #2 and #3 to provide two -10dBm CW signals to the combiner ports - one at 2MHz, and the other at 2.1MHz. For both generators, output B should lead output A by 90 degrees. These 2 signals must be in quadrature to drive the demo board properly. This is most conveniently accomplished by using signal generators with dual outputs with adjustable phase. An example is the HP3326A shown in Figure 1.
7. To measure 3<sup>rd</sup> order distortion and conversion gain, set the Spectrum Analyzer start and stop frequencies to 2001.8MHz and 2002.3MHz, respectively. Sufficient spectrum analyzer input attenuation should be used to avoid distortion in the instrument.
8. The 3<sup>rd</sup> order intercept point is equal to  $(P_1 - P_3) / 2 + P_1$ , where  $P_1$  is the average power level of the two fundamental output tones at 2002MHz and 2002.1MHz;  $P_3$  is the average power level of the two 3<sup>rd</sup> order products at 2001.9MHz and 2002.2MHz. All units are in dBm.
9. To measure 2<sup>nd</sup> order distortion, set the Spectrum Analyzer start and stop frequencies to 2001MHz and 2005MHz, respectively. Sufficient spectrum analyzer input attenuation should be used to avoid distortion in the instrument.
10. The 2<sup>nd</sup> order intercept point is equal to  $2 * P_1 - P_2$ , where  $P_1$  is the power level of the fundamental output tone at 2002MHz,  $P_2$  is the 2<sup>nd</sup> order product at 2004.1MHz. All units are in dBm.

# QUICK START GUIDE FOR DEMONSTRATION CIRCUIT 945 HIGH LINEARITY DIRECT QUADRATURE MODULATOR

Figure 1. Proper Measurement Equipment Setup

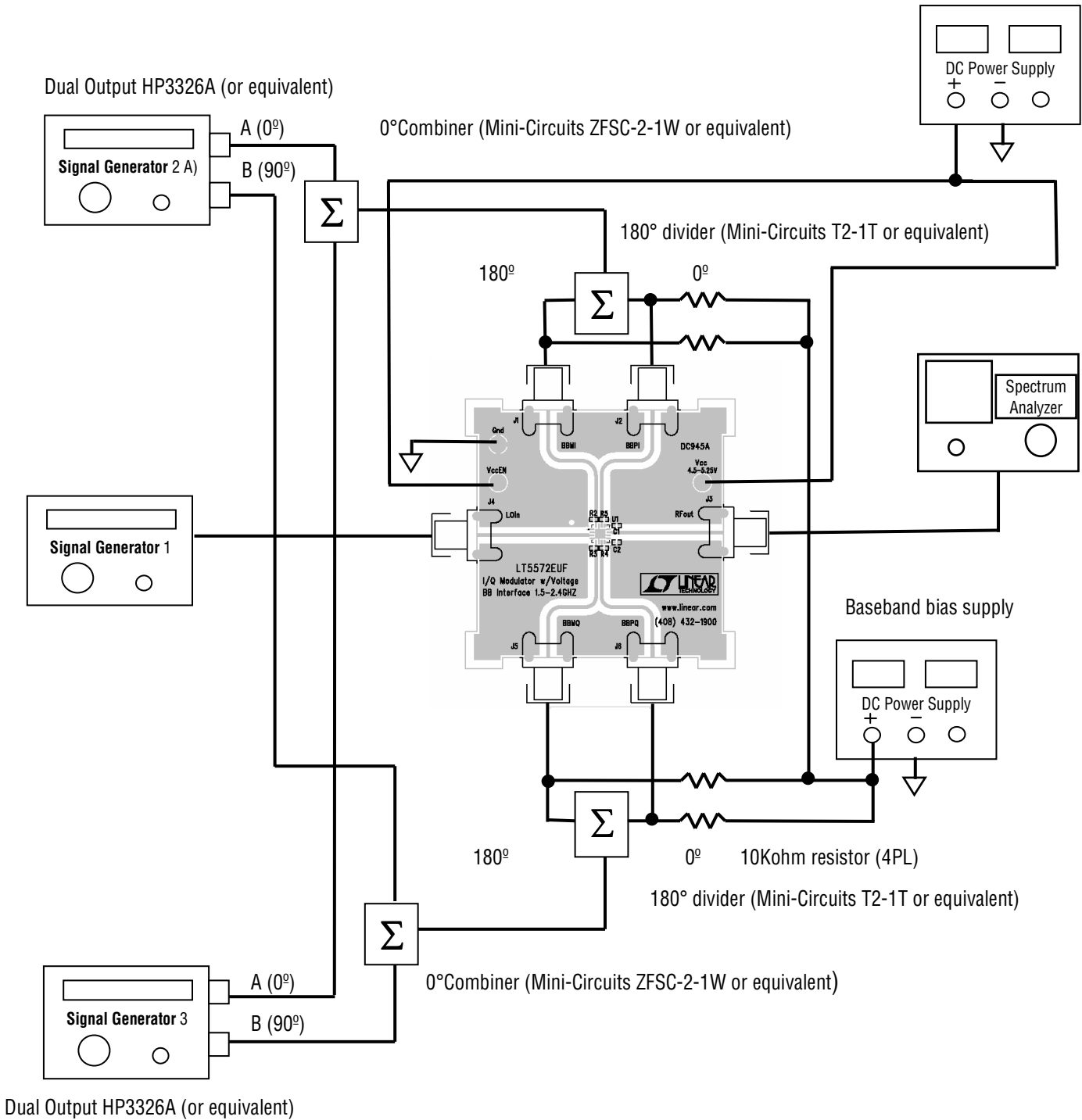

Dual Output HP3326A (or equivalent)

# QUICK START GUIDE FOR DEMONSTRATION CIRCUIT 945

## HIGH LINEARITY DIRECT QUADRATURE MODULATOR

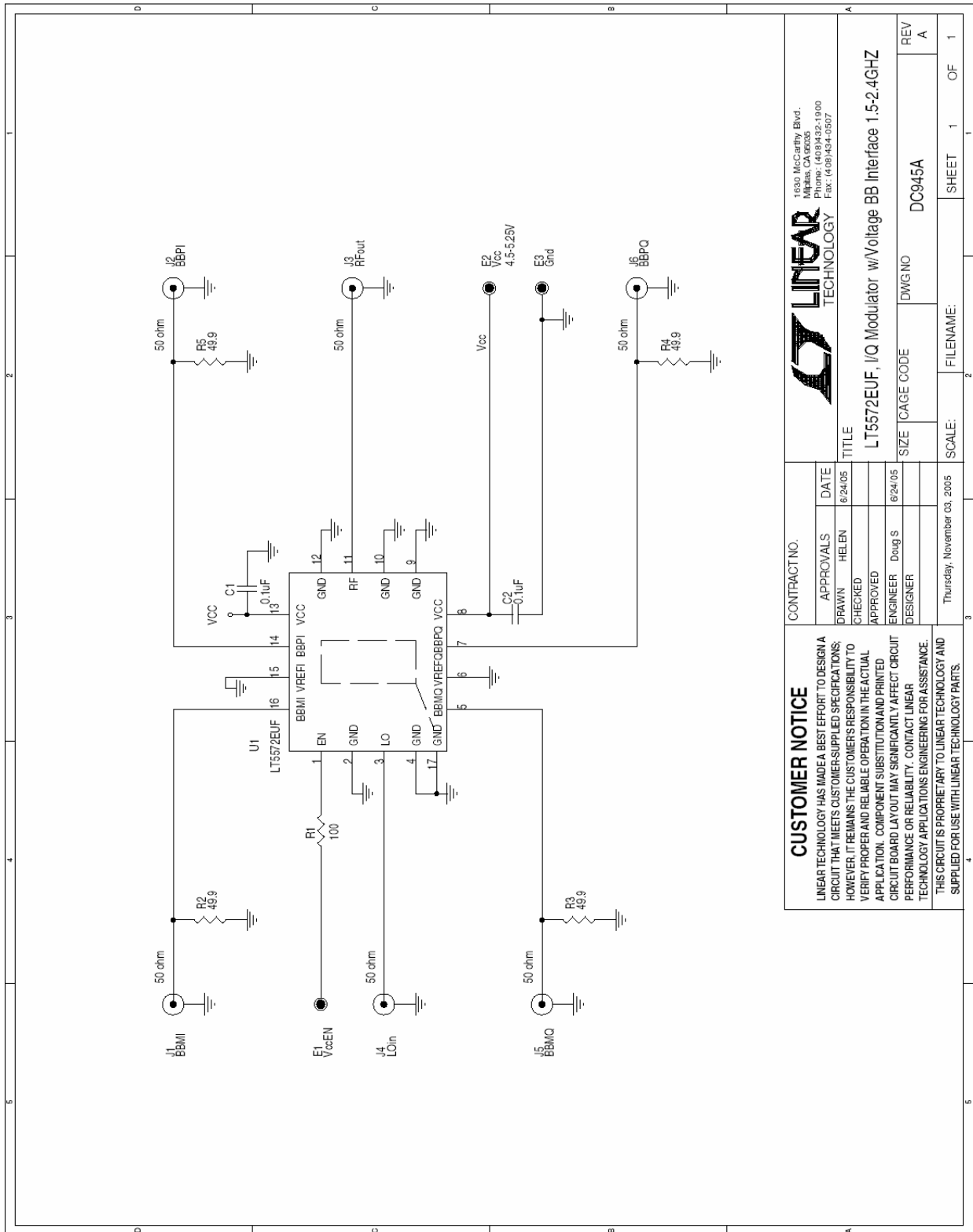

<b>CUSTOMER NOTICE</b>		<b>CONTRACT NO.</b>	
LINEAR TECHNOLOGY HAS MADE A BEST EFFORT TO DESIGN A CIRCUIT THAT MEETS CUSTOMER-SUPPLIED SPECIFICATIONS; HOWEVER, IT REMAINS THE CUSTOMER'S RESPONSIBILITY TO VERIFY PROPER AND RELIABLE OPERATION IN THE ACTUAL APPLICATION. COMPONENT SUBSTITUTION AND PRINTED CIRCUIT BOARD LAYOUT MAY SIGNIFICANTLY AFFECT CIRCUIT PERFORMANCE OR RELIABILITY. CONTACT LINEAR TECHNOLOGY APPLICATIONS ENGINEERING FOR ASSISTANCE. THIS CIRCUIT IS PROPRIETARY TO LINEAR TECHNOLOGY AND SUPPLIED FOR USE WITH LINEAR TECHNOLOGY PARTS.			
APPROVALS	DATE	1830 McCarty Blvd. Milpitas, CA 95035 Phone: (408)432-1900 Fax: (408)434-0567	
DRAWN HELEN	6/24/05	<b>LINEAR TECHNOLOGY</b>	
CHECKED		TITLE	
APPROVED		LT5572EUF, IQ Modulator w/Voltage BB Interface 1.5-2.4GHZ	
ENGINEER Doug S	6/24/05	SIZE	DWG NO
DESIGNER		ICAGE CODE	DC945A
Thursday, November 03, 2005		SCALE:	FILENAME:
		SHEET 1	OF 1