



P-DUKE POWER

MAD65 Single Series

2 X 3 Inch AC-DC POWER SUPPLIES
Up to 65 Watts

5
YEARS
WARRANTY

ROHS
COMPLIANT

REACH
COMPLIANT

+85°C
-40°C
AMBIENT TEMP.



Medical



Automation



Datacom



IPC



Industry



Measurement



Telecom



Automobile



Boat



Charger



PV



Railway

UL US CB CE UK CA



2 x MOPP
4000 VAC Reinforced Insulation
ADJ. Output Voltage
Internal EN55032 Class Filter B
LOW Leakage Current
LOW Standby Power
Operating Altitude 5000 meter
Protection Class I Class II
OCP
OVP
SCP

PART NUMBER STRUCTURE

M	A	D	65	U	S	12	C	-	□
Application	Package Code	Dimension Code	Output Power (W)	Input Voltage (VAC)	Output Quantity	Output Voltage (VDC)	Protection Type		Connector Options
Medical Application	A:Open type U:U chassis type E:Enclosed type D:Din rail type			U:Universal 85 ~ 264	S:Single	05:5 7P5:7.5 09:9 12:12 15:15 18:18 24:24 241:24 28:28 281:28 36:36 48:48 53:53	C:CLASS I D:CLASS II □:CLASS I (※NRND) B:CLASS II (※NRND)		□: JST M: Molex T: Terminal Block
							※NRND:Not recommended for new designs		



TECHNICAL SPECIFICATION All specifications are typical at 230VAC input, full load and 25°C unless otherwise noted

Model Number	Input Range	Output Voltage	Output Current Natural Convection	Max. Output Power	Input Power @No Load	Efficiency	Maximum Capacitor Load
	VAC	VDC	A	W	W	%	µF
MAD65US05C MUD65US05C MED65US05C MDD65US05C	85 ~ 264	5	10	50	0.11	90	20000
MAD65US7P5C MUD65US7P5C MED65US7P5C MDD65US7P5C	85 ~ 264	7.5	8.67	65	0.11	90	11560
MAD65US09C MUD65US09C MED65US09C MDD65US09C	85 ~ 264	9	7.23	65	0.11	91	8033
MAD65US12C MUD65US12C MED65US12C MDD65US12C	85 ~ 264	12	5.42	65	0.11	92.5	4520
MAD65US15C MUD65US15C MED65US15C MDD65US15C	85 ~ 264	15	4.34	65	0.11	93.5	2900
MAD65US18C MUD65US18C MED65US18C MDD65US18C	85 ~ 264	18	3.62	65	0.11	93.0	2015
MAD65US24C MUD65US24C MED65US24C MDD65US24C	85 ~ 264	24	2.71	65	0.11	93.5	1130
MAD65US241C MUD65US241C MED65US241C MDD65US241C	85 ~ 264	24	2.71	65	0.11	92	1130
MAD65US28C MUD65US28C MED65US28C MDD65US28C	85 ~ 264	28	2.33	65	0.11	93.5	830
MAD65US281C MUD65US281C MED65US281C MDD65US281C	85 ~ 264	28	2.33	65	0.11	91.5	830
MAD65US36C MUD65US36C MED65US36C MDD65US36C	85 ~ 264	36	1.81	65	0.11	92.5	520



Model Number	Input Range	Output Voltage	Output Current Natural Convection	Max. Output Power	Input Power @No Load	Efficiency	Maximum Capacitor Load
	VAC	VDC	A	W	W	%	μF
MAD65US48C MUD65US48C MED65US48C MDD65US48C	85 ~ 264	48	1.36	65	0.11	93	285
MAD65US53C MUD65US53C MED65US53C MDD65US53C	85 ~ 264	53	1.24	65	0.11	92.5	235

INPUT SPECIFICATIONS

Parameter	Conditions	Min.	Typ.	Max.	Unit
Operating input voltage range	AC input	85		264	VAC
	DC input	120		370	VDC
Input frequency	AC input	47		63	Hz
Input current	100VAC and Full Load 240VAC and Full Load			1.6 0.9	A
No load input power	230VAC		0.11		Watts
Leakage current	264VAC		75		μA
Start up time				1000	ms
Rise time			20		ms
Hold up time	115VAC and Full Load		16		ms
Input inrush current	230VAC		60		A
Input protection	Internal fuse in line and neutral			T3.15A/250VAC	

OUTPUT SPECIFICATIONS

Parameter	Conditions	Min.	Typ.	Max.	Unit
Output power				65	Watts
Initial set voltage accuracy	230VAC and Full Load	-1.0		+1.0	%
Line regulation	Low Line to High Line at Full Load	-0.2		+0.2	%
Load regulation	No Load to Full Load	-0.7		+0.7	%
	10% Load to 90% Load	-0.5		+0.5	
Voltage adjustability	Single output	5Vout		+0.6	%
		Others	-0.4	+0.4	
		53Vout	-20	+10	
Minimum load			0		%
Ripple and noise	Measured by 20MHz bandwidth With a 10μF/25V 1206 X7R MLCC	5Vout, 7.5Vout, 9Vout	75		mVp-p
		12Vout, 15Vout, 18Vout	75		
	With a 1μF/50V 1206 X7R MLCC With a 0.1μF/100V 1206 X7R MLCC	24Vout, 28Vout, 36Vout	75		
		48Vout, 53Vout	150		
Temperature coefficient		-0.02		+0.02	%/°C
Transient response	Load step from 50 ~ 75% change at 2.5A/μs			3	% Vout
	Peak deviation		600		μs
	Recovery time				
Over voltage protection	% of Vout(nom); Latch mode	125		140	%
Over load protection	% of Iout rated; Hiccup mode		145		%
Short circuit protection					Continuous, automatic recovery

GENERAL SPECIFICATIONS

Parameter	Conditions		Min.	Typ.	Max.	Unit
Isolation voltage	1 minute (2MOPP insulation)	Input to Output Input (Output) to F.G.	4000 2500			VAC
Isolation resistance	500VDC		0.1			GΩ
Switching frequency	230VAC	5Vout 7.5Vout 9Vout Others		60 80 70 120		kHz
Safety approvals	IEC/ EN/ ANSI/AAMI ES 60601-1 IEC/ EN/ UL 62368-1					UL:E360199 UL:E193009 CB:UL(Demko)
Weight		MAD MUD MED MDD				117g (4.13oz) 157g (5.54oz) 172g (6.07oz) 193g (6.81oz)
MTBF	MIL-HDBK-217F, Full load					1.257 x 10 ⁶ hrs

ENVIRONMENTAL SPECIFICATIONS

Parameter	Conditions		Min.	Typ.	Max.	Unit
Operating ambient temperature	Natural convection	With derating	-40		+85	°C
Storage temperature range			-40		+85	°C
Operating altitude					5000	m
Shock						IEC60068-2-27
Vibration						IEC60068-2-6
Relative humidity	Non-condensing					5% to 95% RH

EMC SPECIFICATIONS

Parameter	Conditions		Level		
EMI	EN55011, EN55032, EN60601-1-2 and FCC Part 18 / 15		Conducted		Class B
	External components may be required for class I application.		Radiated		Class B
Harmonic currents	EN61000-3-2	Full Load			Class A
Voltage flicker	EN61000-3-3				
EMS	EN55035 and EN60601-1-2				
ESD	EN61000-4-2				Perf. Criteria A
Radiated immunity	EN61000-4-3	20 V/m			Perf. Criteria A
Fast transient	EN61000-4-4	± 2kV			Perf. Criteria A
Surge	EN61000-4-5	DM ± 1kV and CM ± 2kV			Perf. Criteria A
Conducted immunity	EN61000-4-6	20 Vr.m.s			Perf. Criteria A
Power frequency magnetic field	EN61000-4-8	30 A/m			Perf. Criteria A
Dip and interruptions	EN61000-4-11				

CHARACTERISTIC CURVE

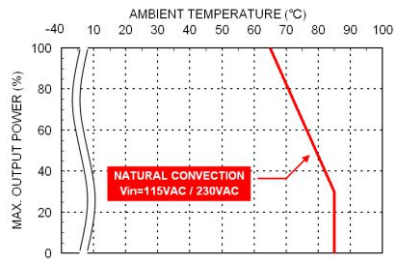

Derating Curve vs. Ambient Temperature

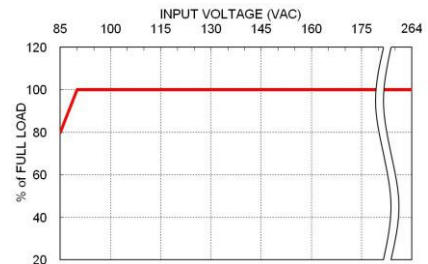

Derating Curve vs. Input Voltage

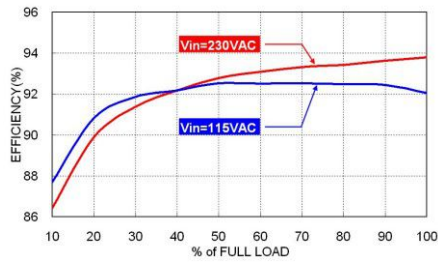

Efficiency VS Output Load
M□D65US24C

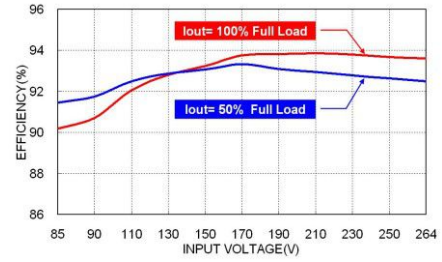

Efficiency VS Input Voltage
M□D65US24C

MECHANICAL DRAWING

MAD Open type

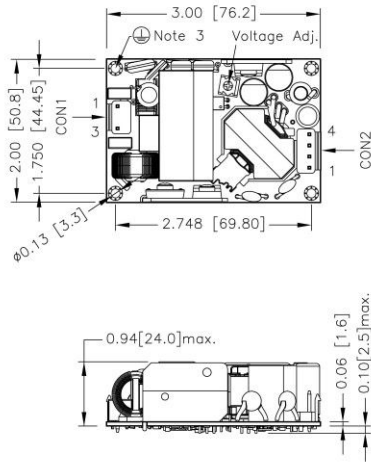

FRONT VIEW

- All dimensions in inch [mm]
Tolerance : $x.xx \pm 0.02$ [$x.x \pm 0.5$] $x.xxx \pm 0.010$ [$x.xx \pm 0.25$]
- The screw locked torque: MAX 5.0kgf-cm/0.49N-m
- The screws holes can be considered as PE connection for CLASS I application.

MDD Din rail type

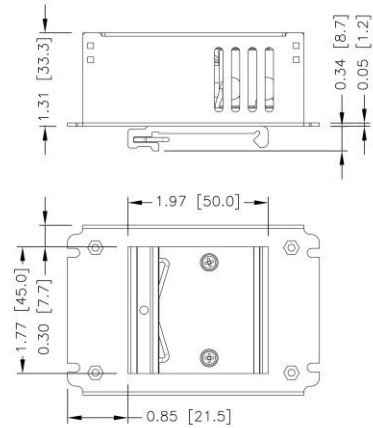

BOTTOM VIEW

- All dimensions in inch [mm]
Tolerance : $x.xx \pm 0.02$ [$x.x \pm 0.5$] $x.xxx \pm 0.010$ [$x.xx \pm 0.25$]

MED Enclosed type

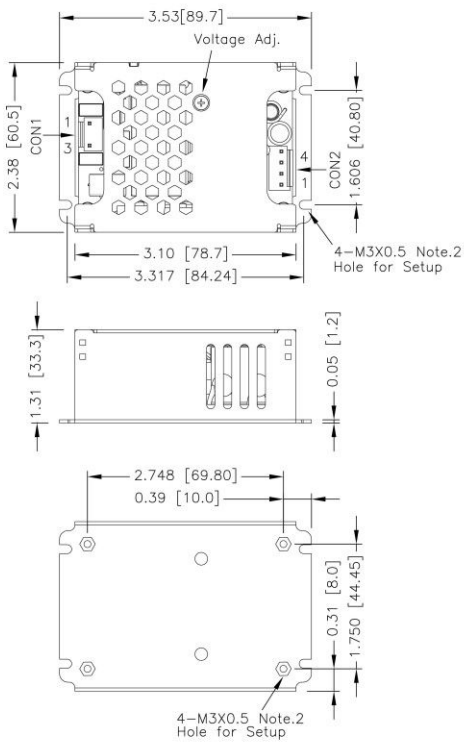

BOTTOM VIEW

- All dimensions in inch [mm]
Tolerance : $x.xx \pm 0.02$ [$x.x \pm 0.5$] $x.xxx \pm 0.010$ [$x.xx \pm 0.25$]
- The screw locked torque: MAX 5.0kgf-cm/0.49N-m

MUD U chassis type

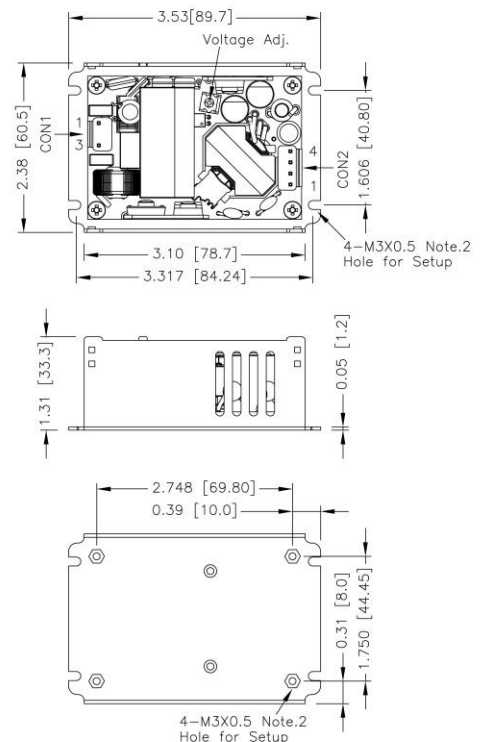

BOTTOM VIEW

- All dimensions in inch [mm]
Tolerance : $x.xx \pm 0.02$ [$x.x \pm 0.5$] $x.xxx \pm 0.010$ [$x.xx \pm 0.25$]
- The screw locked torque: MAX 5.0kgf-cm/0.49N-m

CONNECTOR CONNECTIONS

CON1 – Input Connector

Pin Number	AC Input	DC Input
		M□D65USXXC · M□D65USXXD
Pin 1	Line	DC+
Pin 3	Neutral	DC-

CON2 – Output Connector

Pin 1,2	-Vout
Pin 3,4	+Vout

*Either one of four screws holes of Chassis type can be considered as PE connection for CLASS I application.

CONNECTOR OPTIONS

Blank:

JST Type

Mates with housing

CON1: **VHR-3N**

CON2: **VHR-4N**



Crimp terminals

CON1: **SVH-21T-P1.1**

CON2: **SVH-21T-P1.1**

-M

Molex Type

Mates with housing

CON1: **09-50-8031**

CON2: **09-50-8041**



Crimp terminals

CON1: **SD-2478**

CON2: **SD-2478**

-T

Terminal Block

Mates with

**Screw locked torque
MAX 2Kgf.cm/0.2N.m**



**Wire dimension range
26 ~ 16AWG**