

LTC6410-6 Differential IF Amplifier

DESCRIPTION

Demonstration circuit 1103 features the LTC6410-6 low noise, low distortion differential Intermediate Frequency (IF) Amplifier. It incorporates a variety of passive components to support configurations for varied applications. Single-ended or differential input and output configurations are possible, and there is a test/calibration circuit to null out the effects of on-board circuit components.

The LTC6410-6 is a high-speed differential amplifier with 6dB of voltage gain and superior distortion and noise performance, perfect for demanding communications transceivers, cellular base-stations, and other high-speed signal

chain applications. The LTC6410-6 features a fully differential input and output and is capable of directly driving a 50Ω load. One standout feature of the LTC6410-6 is the ability to independently adjust the input impedance with two resistors at the inputs. This allows the user to easily enhance the noise figure and power gain of the system for optimal performance.

Design files for this circuit board are available. Call the LTC factory.

 , LTC and LT are registered trademarks of Linear Technology Corporation.

QUICK START PROCEDURE

Table 1 shows the function of each SMA connector on the board. Refer to Figure 1 for the connection diagram and follow the procedure below:

1. Connect the power supply as shown. The LTC6410-6 accepts supply voltages from 2.8-5.5V. The power labels of VCC, $\overline{\text{SHDN}}$, and GND directly correspond to the V+, $\overline{\text{SHDN}}$, and V- pins of the LTC6410-6, respectively. Jumper JP1 shuts down the LTC6410-6.
2. For network analyzer use, the user can calibrate out board and transformer effects using J6 and J7.
3. Apply an input signal to J2. A low-distortion, low noise signal source with an external high-order filter will yield the best performance (this does not apply to network analysis). DC1103's input is impedance-matched to 50Ω by default; no external termination is necessary.
4. Observe the output via J5. The output is capable of driving a 50Ω load, such as the input of a network or spectrum analyzer. By default, the output is impedance-matched to 50Ω.

Table 1: DC1103 Connector Descriptions

CONNECTOR	FUNCTION
J1 (-IN)	Differential Input. Not connected by default. Capacitor R6 can be installed and R2 removed to drive the DC1103 differentially.
J2 (+IN)	Differential Input. Use this connector to supply an input to the DC1103. Drive from a 50Ω signal source, no external termination necessary.
TP4 (VBIAS)	Self-Bias Voltage Adjust. By default, 1.45V is supplied to this pin by two resistors (VCC=3V). Override this voltage with any low-impedance DC voltage source.
J4 (-OUT)	Differential Output. Not connected by default. Capacitor R12 can be installed and R14 removed for differential output drive.
J5 (+OUT)	Output. Impedance-matched to 50Ω, can be used to drive a 50Ω network/spectrum analyzer input.
J6 (TEST IN)	Calibration network input. Use with a network analyzer to calibrate out effects of board trace parasitics, transformers, and SMA connectors.
J7 (TEST OUT)	Calibration network output.

DEMO CIRCUIT DC1103 QUICK START GUIDE

LOW NOISE, LOW DISTORTION DIFFERENTIAL IF AMPLIFIER

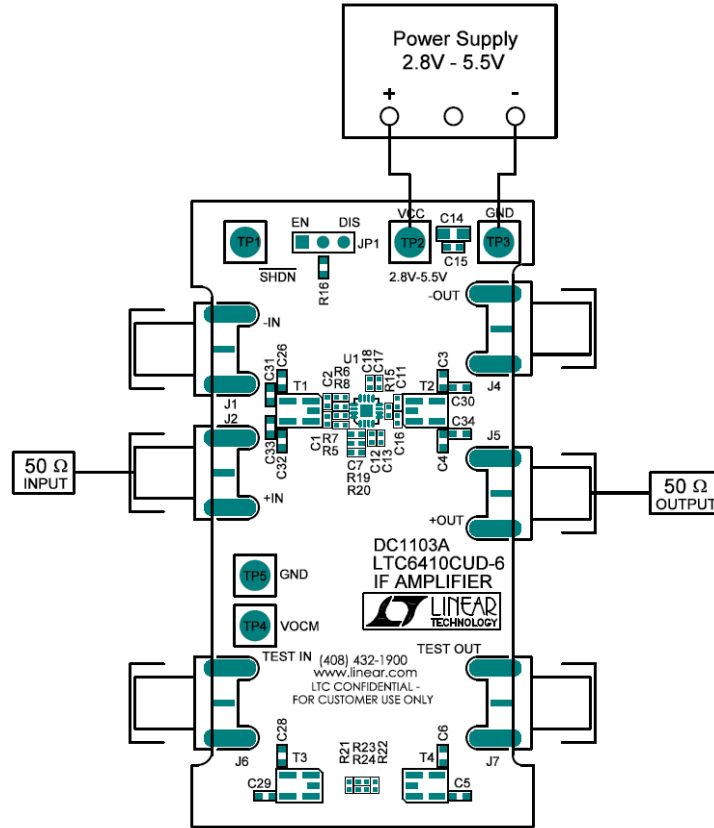

Proper Measurement Equipment Setup

ADDITIONAL INFORMATION

Although the DC1103 demo board is ready to use out of the box, it has features that you can access by adding, removing or changing components on the board. This and other important board information are included in this section.

DIFFERENTIAL INPUTS

To drive the inputs differentially, remove capacitor C31 and install C26. J1 and J2 can now be driven differentially from a 50Ω signal source. The input to the DC1103 will still be matched to 50Ω (differential) when driven in this manner.

SMA CONNECTOR SPACING

The input SMA connectors are spaced 0.6” (15.24mm) apart, suitable for direct connection to the DC1119 demo board for Linear Technology’s LT5527, LT5557, and LT5559 high linearity downconverting mixers.

The output SMA connectors are spaced 0.8” (20.32mm) apart, suitable for direct connection to various Linear Technology amplifier/ADC-driver demo boards such as DC800 (LT1993) and DC987 (LTC6400, LTC6401).

ADJUSTING THE INPUT IMPEDANCE

The input impedance of the LTC6410 can be adjusted in the range of 58Ω-2000Ω by replacing R5 and R6 with equal-value non-zero resistors. The correct resistor value for the desired *differential* input impedance is:

$$R_5, R_6 = \frac{(3810 \cdot Z_{DIFF}) - 220000}{2000 - Z_{DIFF}}$$

Adjusting the input impedance too high may affect the performance of the part. See the LTC6410 datasheet.

DEMO CIRCUIT DC1103 QUICK START GUIDE

LOW NOISE, LOW DISTORTION DIFFERENTIAL IF AMPLIFIER

DC COUPLING THE INPUTS/OUTPUTS

It is possible to DC couple the LTC6410 in the signal chain. Capacitors C26, C32 and C3-C4 should be replaced with 0Ω resistors. Additionally, C30 and C31 should be removed. As a warning, the input impedance of the LTC6410-6 can cause large input bias currents if DC1103 is DC-coupled at the inputs. Additionally, the inputs must be DC-biased to within the common-mode range of the LTC6410.

If transformers T1 and T2 are transmission-line transformers (the transformers included on-board are TLTs), DC voltages and currents will propagate through at the input and output unless AC-coupling capacitors are installed.

When DC coupling the inputs, it may also be desirable to DC couple the TERM inputs of the LTC6410 to the signal inputs. To do this, replace C1 and C2 with 0Ω resistors. This will achieve a wideband (down to DC frequency) impedance match at the input, at the expense of increased common-mode output offset. See the LTC6410 datasheet for details.

The outputs of the LTC6410 will self-bias to the voltage at the V_{OCM} pin. If DC-coupled, the load to ground at each output should be considered so that excessive current is not drawn from the outputs. A differential R_{LOAD} should be installed at R15 instead to avoid large quiescent load currents. On the demo board, capacitor C30 should be removed for this reason if DC coupling at the output.

DIFFERENTIAL OUTPUTS

To use the both outputs of the DC1103, remove capacitor C30 and install C3. The output now appears differentially across J4 and J5. The output of the DC1103 will still be matched to 50Ω (differentially) when used in this manner. See the LTC6410 datasheet for more details.

CHANGING THE BIAS VOLTAGE

Turret TP4 controls the self-bias voltage of DC1103. This function can be used to bias the next stage for optimum system performance. If used for this purpose, AC-coupling

capacitors C3 and C4 can be shorted or replaced by 0Ω resistors to allow the DC bias to reach the output. By default, internal resistors supply 1.45V to the V_{BIAS} pin (with $V_{+}=3.0V$). This voltage can be over-ridden with an external voltage source at TP4 and/or by installing resistors R19 and R20.

OUTPUT DRIVE

The output of the LTC6410-6 is designed to directly drive impedances as low as 50Ω . This makes the part suitable for insertion into 50Ω signal chains without special considerations of amplifier loading and impedance matching.

SHUTDOWN

Jumper JP1 and TP1 control the shutdown function of DC1103. When set to the EN position, the part will be on and draw quiescent current. In the DIS position, the part will be in shutdown and draw a very small amount of quiescent current. Remove the JP1 shunt to drive TP1 directly with a voltage source.

NOTE. The V_{OCM} bias resistors R19 and R20 draw current from VCC to GND, and must be accounted for when measuring the current of the LTC6410-6 (especially in shutdown). By default, these resistors are not installed on the board.

CABLES AND CONNECTORS

Long BNC or SMA cables are transmission lines, and for best circuit performance should be kept as short as possible. BNC/SMA cables or barrels should be characterized (or nulled out through calibration) for good high-frequency performance.

SCHEMATIC NOTES

The calibration circuit, as shown in the schematic, contains two extra resistors R21-R22. These resistors are included for added circuit flexibility, and are not typically populated. Additionally, R15, C11, and C16 are included for possible output resistive load or filtering, and are also unpopulated.

DEMO CIRCUIT DC1103 QUICK START GUIDE

LOW NOISE, LOW DISTORTION DIFFERENTIAL IF AMPLIFIER

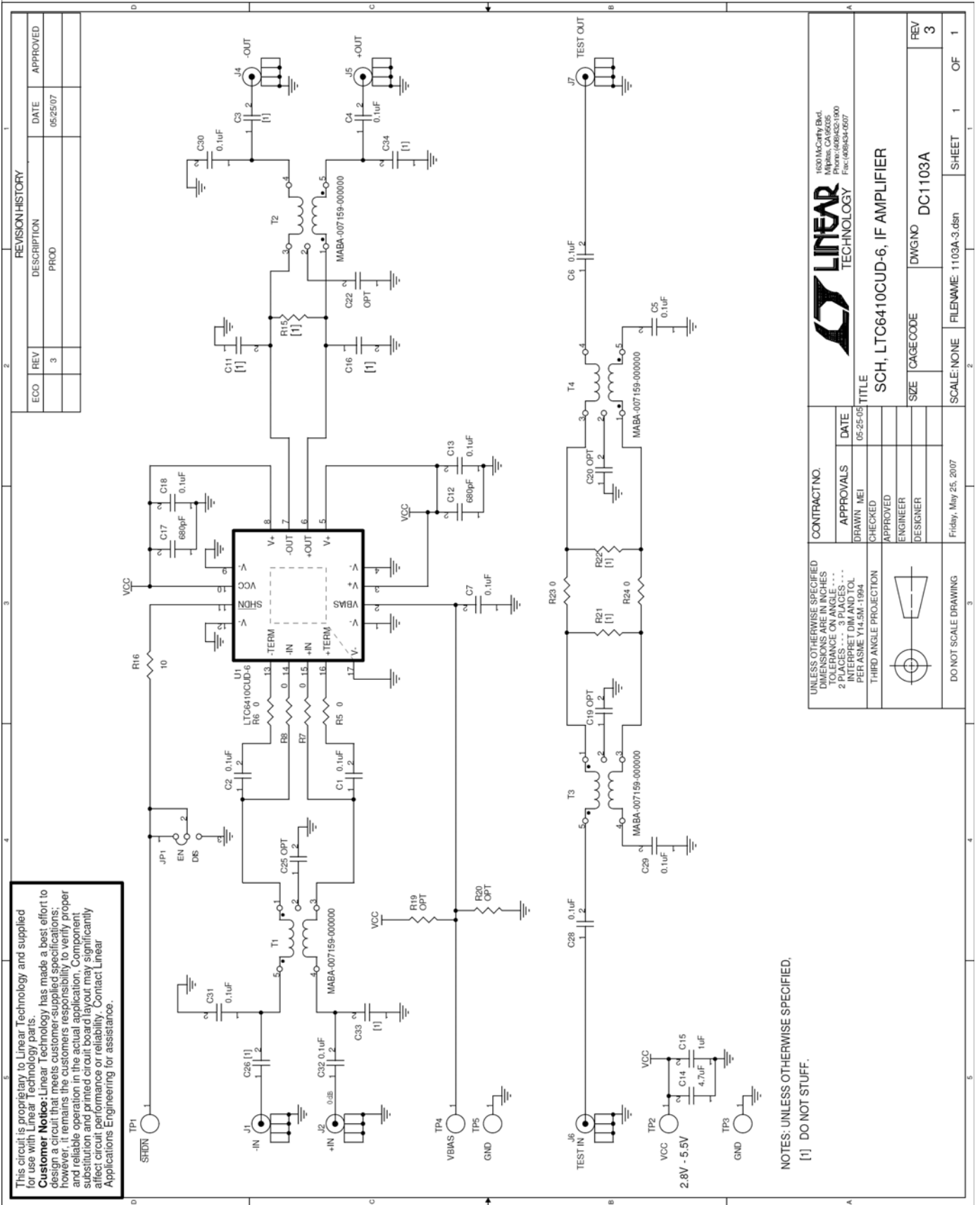

This circuit is proprietary to Linear Technology and supplied for use with Linear Technology parts.

Customer Notice: Linear Technology has made a best effort to design a circuit that meets customer-supplied specifications; however, it remains the customer's responsibility to verify proper and reliable operation in the actual application. Component substitution and printed circuit board layout may significantly affect circuit performance or reliability. Contact Linear Applications Engineering for assistance.

NOTES: UNLESS OTHERWISE SPECIFIED,
[1] DO NOT STUFF.

REVISION HISTORY		REVISION HISTORY	
ECO	REV	DESCRIPTION	DATE
	3	PROD	05/25/07

UNLESS OTHERWISE SPECIFIED DIMENSIONS ARE IN INCHES TOLERANCE ON ANGLE ... 2 DECIMALS ... INTERPRET DIM AND TOL ... PER ASME Y14.5M-1994		CONTRACT NO. APPROVALS DRAWN: MEI CHECKED: MEI APPROVED: _____ ENGINEER: _____ DESIGNER: _____
THIRD ANGLE PROJECTION 		TITLE SCH, LTC6410CUD-6, IF AMPLIFIER
DO NOT SCALE DRAWING		FILENAME: 1103A-3.dsn SHEET: 1 OF 1

1630 McCarty Blvd. Milpitas, CA 95035 Phone: (408)452-1900 Fax: (408)452-0507	LINEAR TECHNOLOGY	SIZE: CAGE CODE: DWGNO: DC1103A REV: 3
--	----------------------	---