

SF2181D

**140 MHz
SAW Filter**

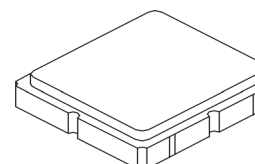

SM3838-8

- 22 MHz Filter Bandwidth
- 3.8 x 3.8 x 1.4 mm Surface-mount Package
- Complies with Directive 2002/95/EC (RoHS)
- Moisture Sensitivity Level: 1
- AEC-Q200 Qualified

Absolute Maximum Ratings

Rating	Value	Units
Maximum Incident Power in Passband	+10	dBm
Maximum DC Voltage between any Two Terminals	3	VDC
Storage Temperature Range in Tape and Reel	-40 to +85	°C
Suitable for Lead-free Soldering - Maximum Soldering Profile	260°C for 30 s	

Electrical Characteristics

Characteristic	Sym	Notes	Min	Typ	Max	Units
Nominal Center Frequency	F_C			140		MHz
Insertion Loss	IL_{MAX}			8	9	dB
Insertion Loss Variation over Temperature					1	dB
3 dB Bandwidth			22	27		MHz
Passband Amplitude Ripple, Matching Network A, 129 to 151 MHz				0.8	1.2	dB _{p-p}
Passband Amplitude Ripple, Matching Network B, 129 to 151 MHz				0.6	1.0	dB _{p-p}
Passband Amplitude Ripple, Matching Network C or D, 130 to 150 MHz				0.9	1.0	dB _{p-p}
Absolute Attenuation (referenced to IL_{MAX})						
10 to 116 MHz			35	40		dB
165 to 700 MHz			35	40		dB
Absolute Group Delay in Passband				300	350	ns
Passband Group Delay Ripple, Matching Network A or B, 129 to 151 MHz				40	80	ns _{p-p}
Input Impedance, Unbalanced Matching Network				50		ohm
Input Impedance, Balanced Matching Network				200		ohm
Input Return Loss through any Matching Network			6	14		dB
Output Impedance, Unbalanced Matching Network				50		ohm
Output Impedance, Balanced Matching Network				200		ohm
Output Return Loss through any Matching Network			6	14		dB
Operating Temperature Range			-40		+85	°C
Case Style			SM3838-8 3.8 x 3.8 mm Nominal Footprint			
Lid Symbolization (Y=year, WW=week, S=shift)			872 , <u>YWWS</u>			

 **CAUTION: Electrostatic Sensitive Device. Observe precautions for handling.**

NOTES:

1. The design, manufacturing process, and specifications of this device are subject to change.
2. US or International patents may apply.
3. RoHS compliant from the first date of manufacture.

SF2181D, Using Matching Network A

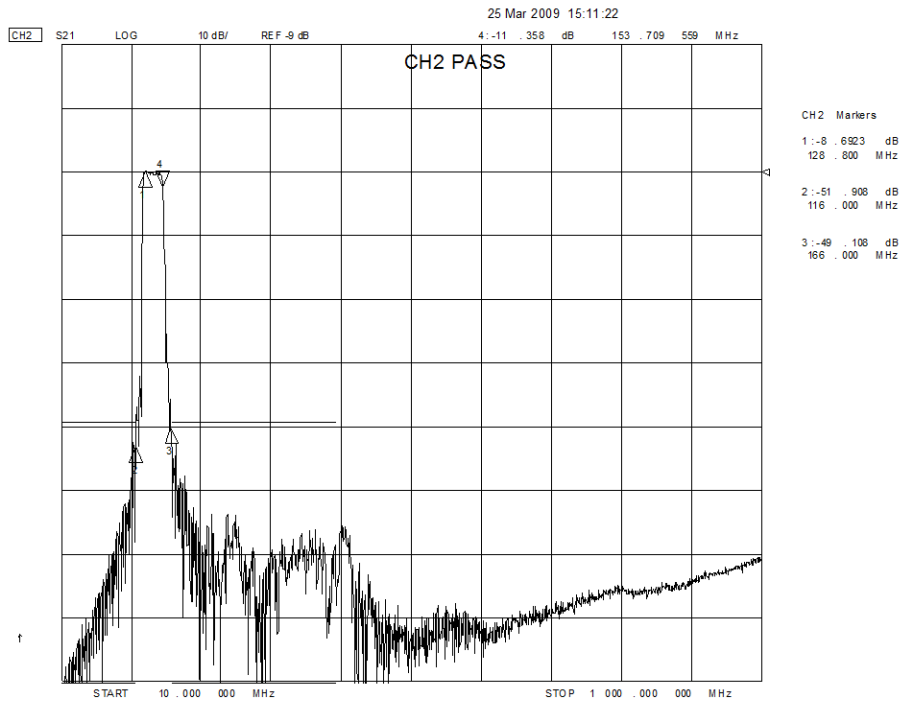
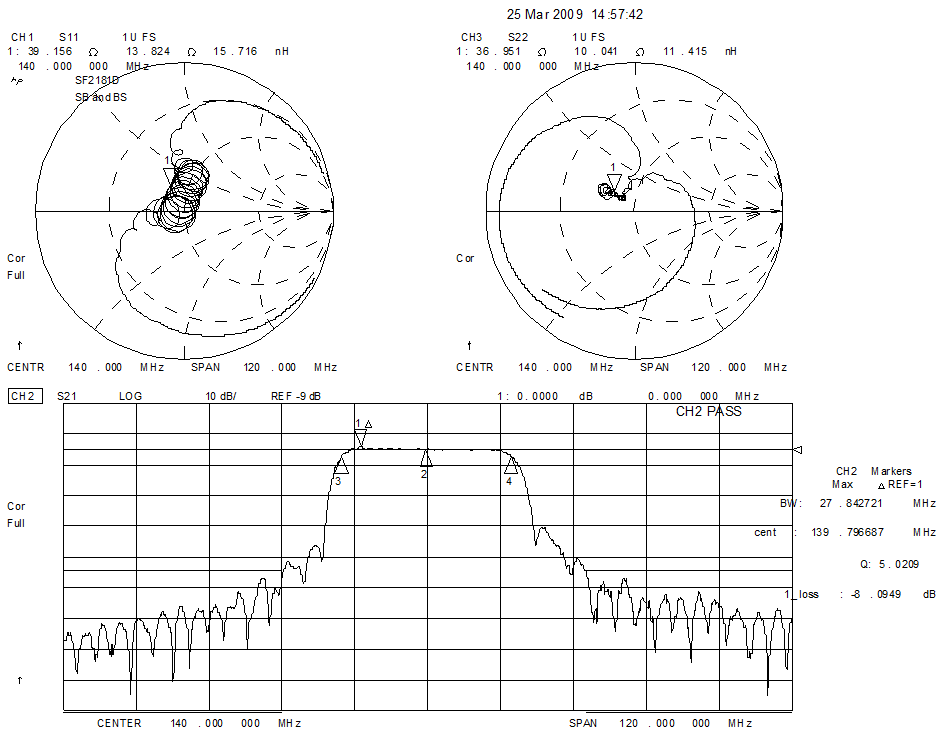

SF2181D, Using Matching Network A

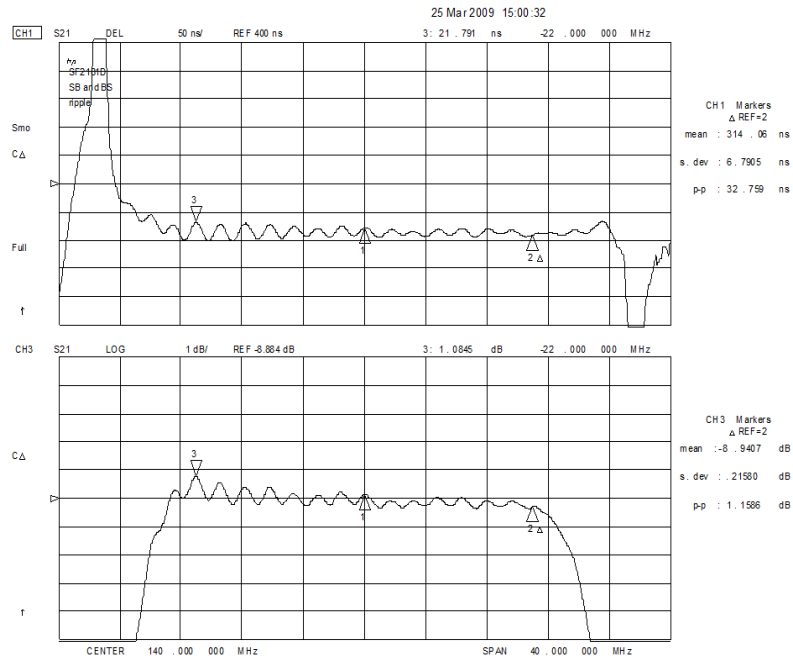
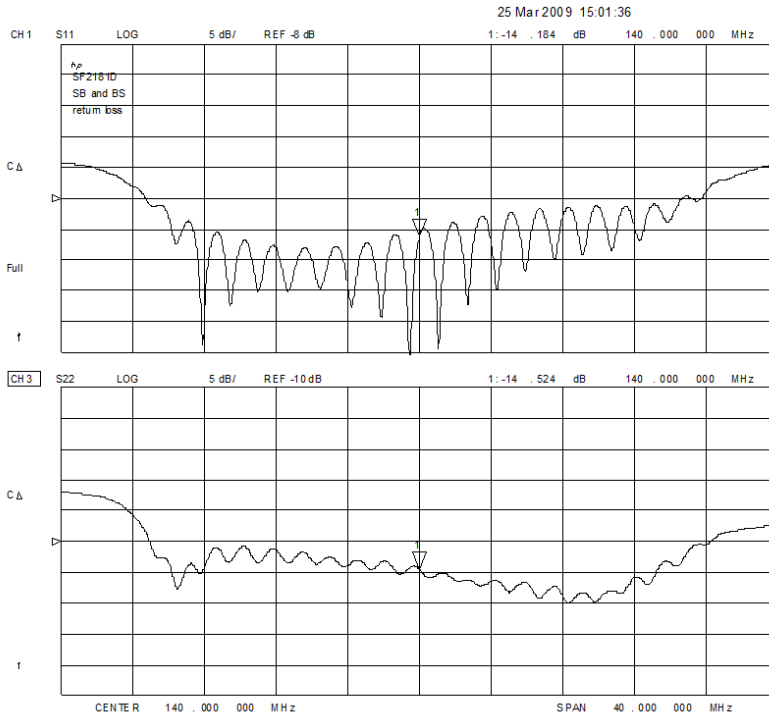

SF2181D, Using Matching Network B

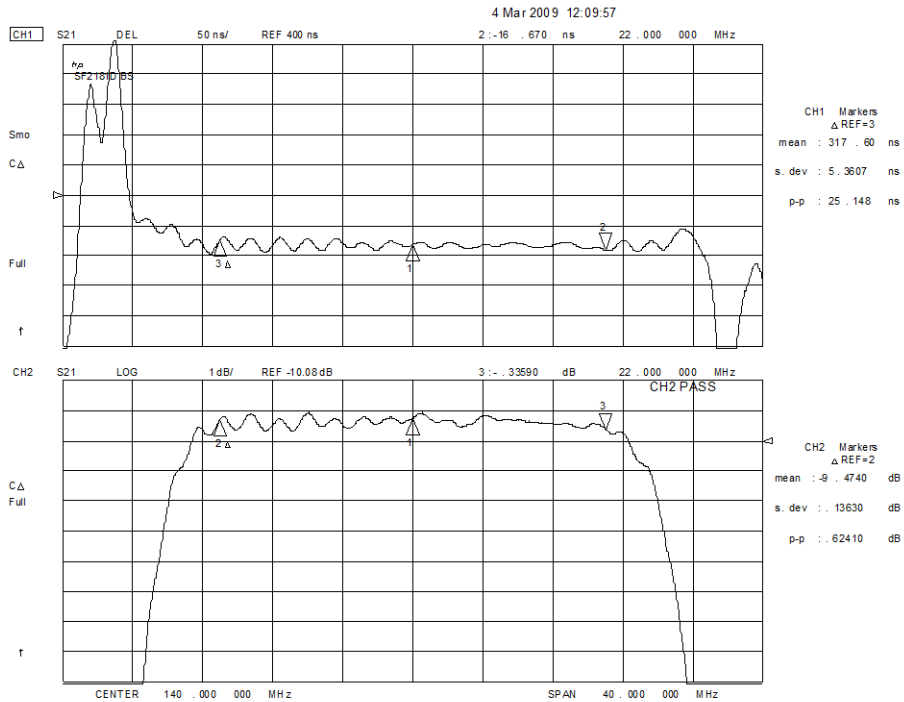
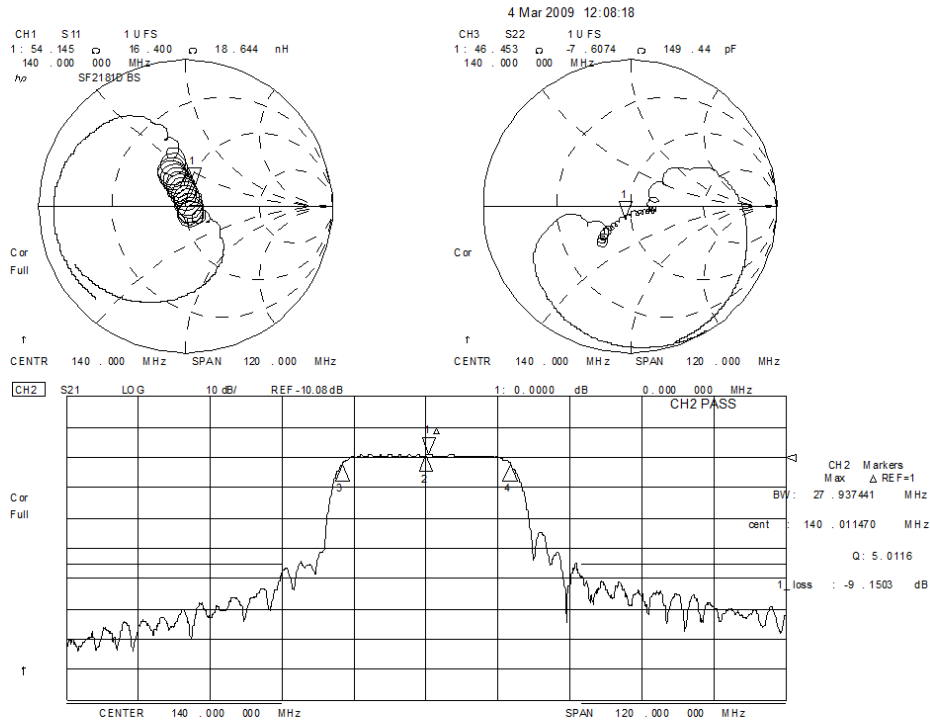

SF2181D, Using Matching Network C

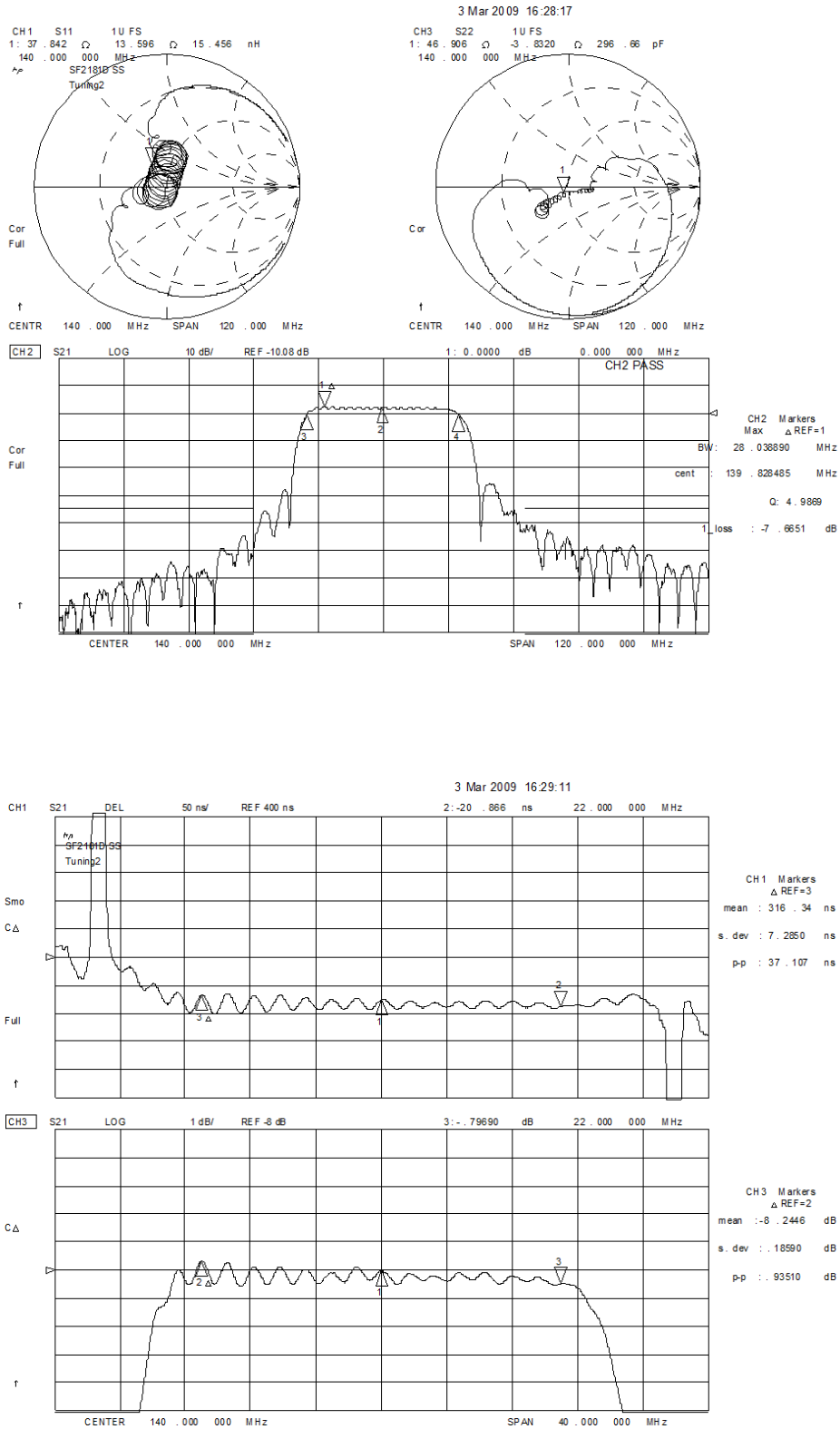

SF2181D, Using Matching Network C

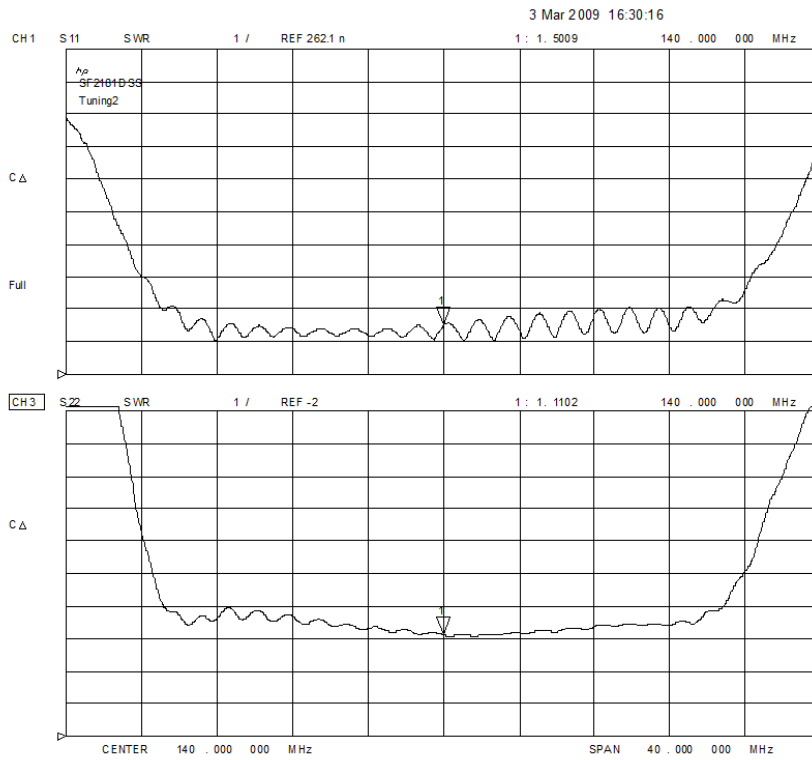

SF2181D, Using Matching Network D

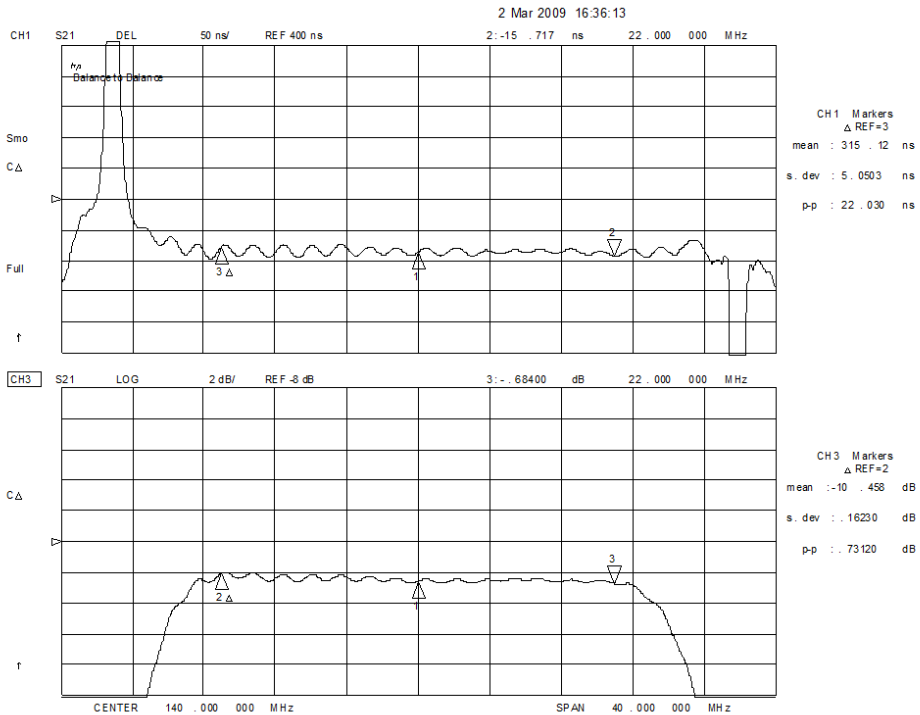
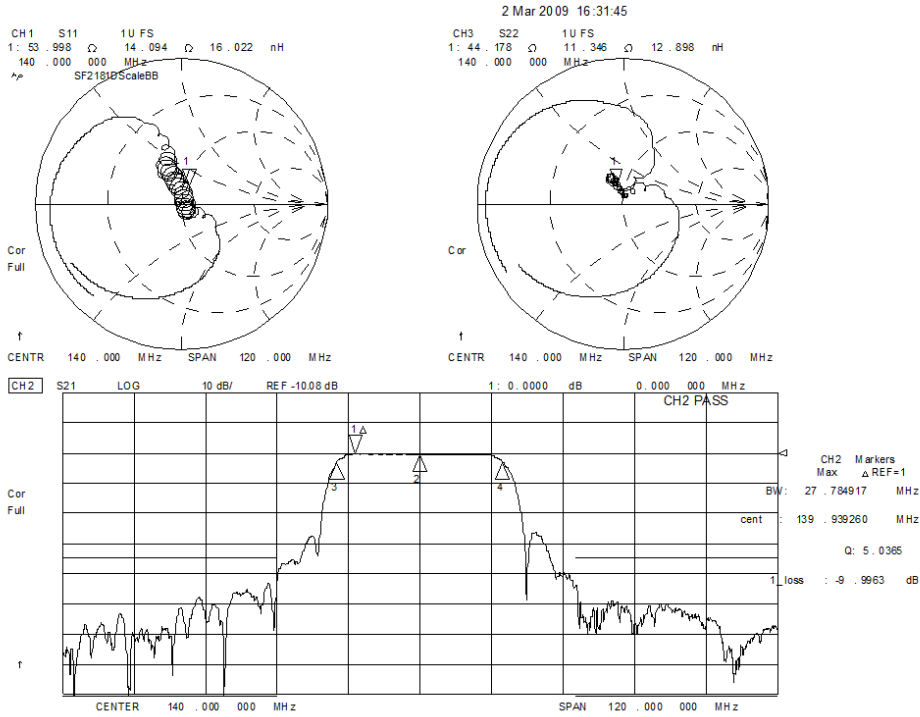

SF2181D, Matching Network A, Two Options

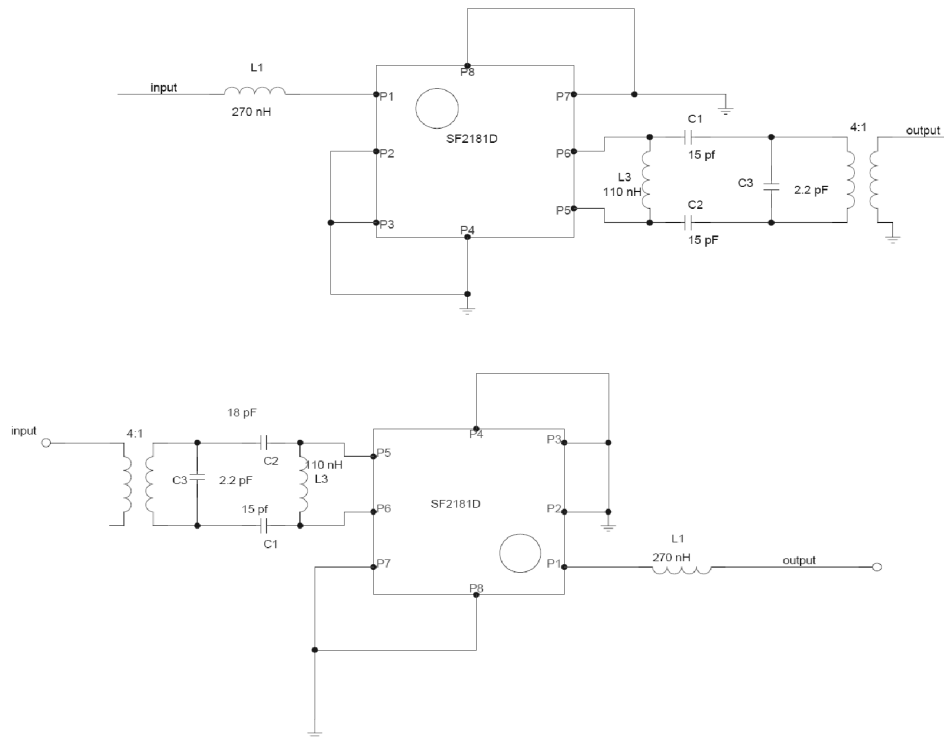

SF2181D, Matching Network B, Two Options

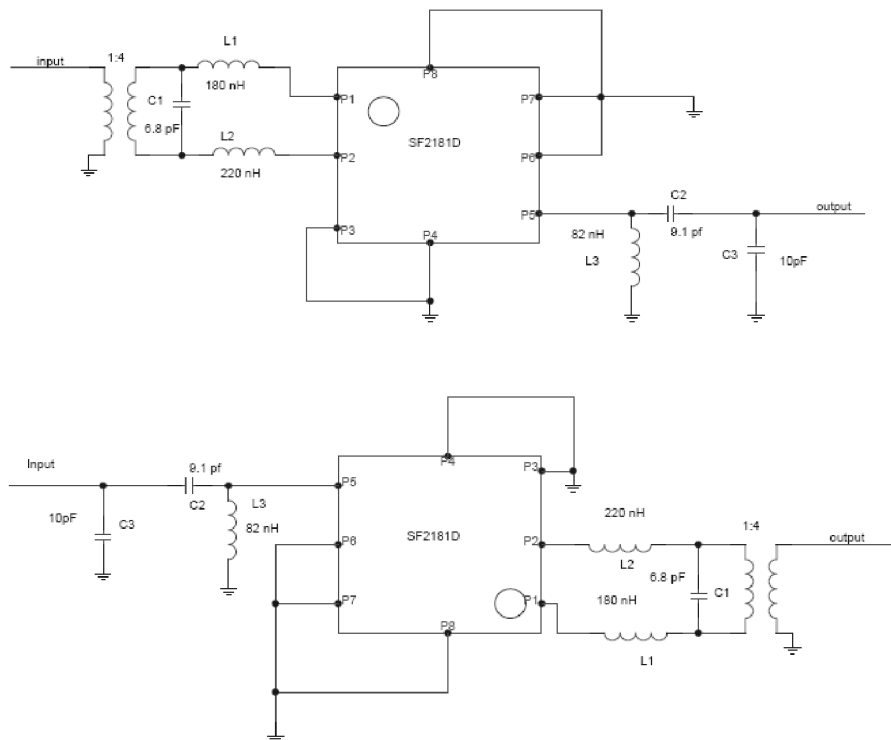

SF2181D, Matching Network C

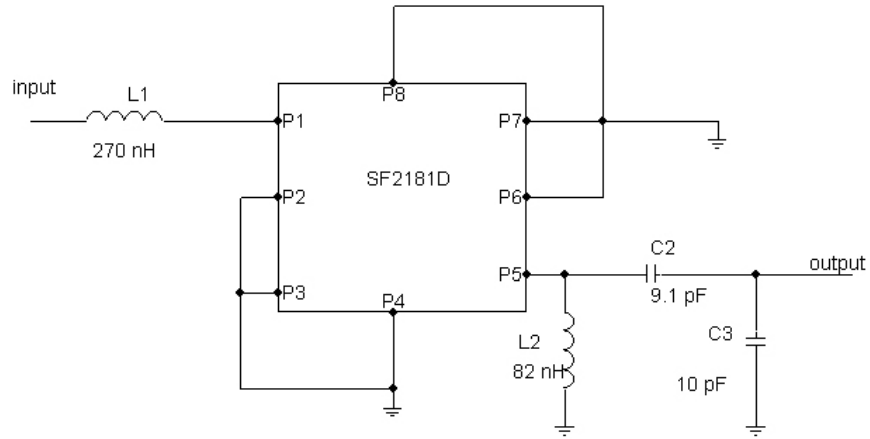

SF2181D, Matching Network D

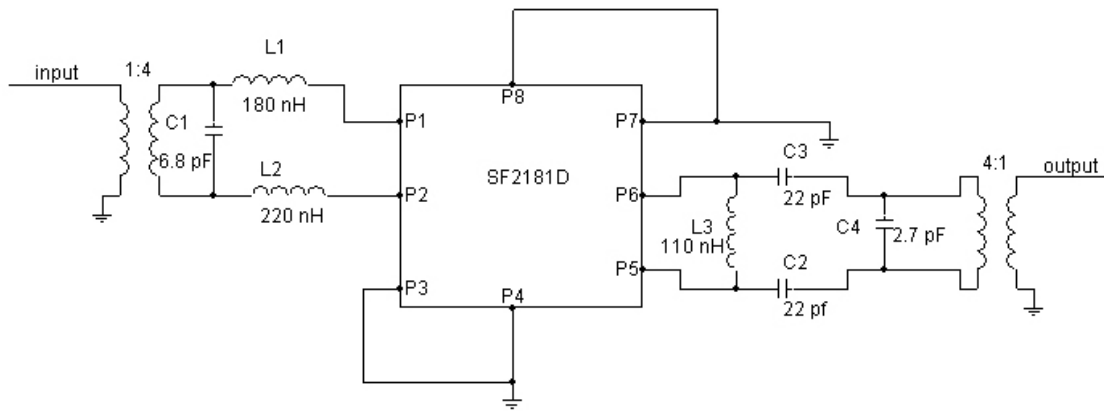

SM3838-8 Case

8-Terminal Ceramic Surface-Mount Case

3.8 X 3.8 mm Nominal Footprint

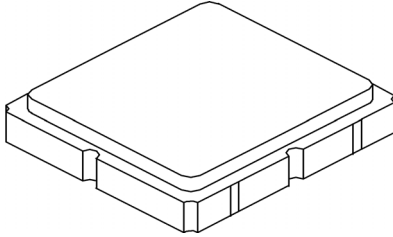

Top View

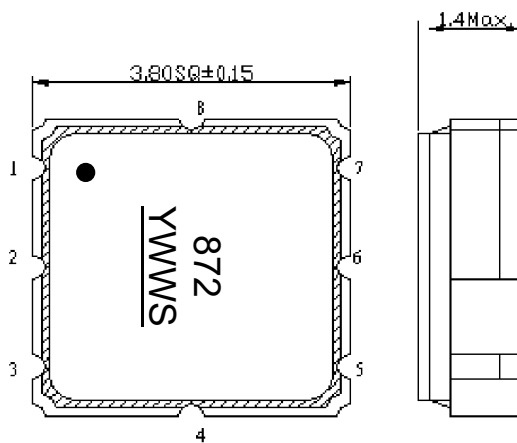

Bottom View

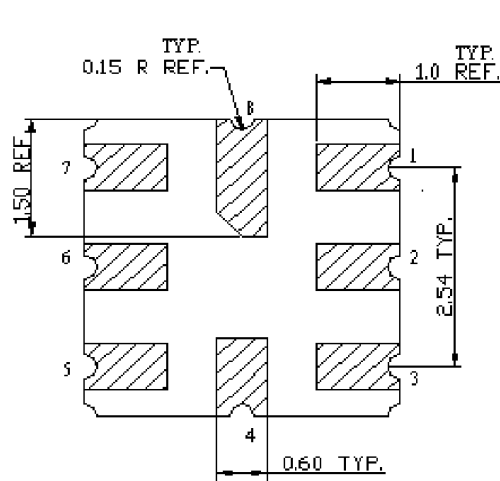

PCB Footprint for 180 Degree Rotation Option

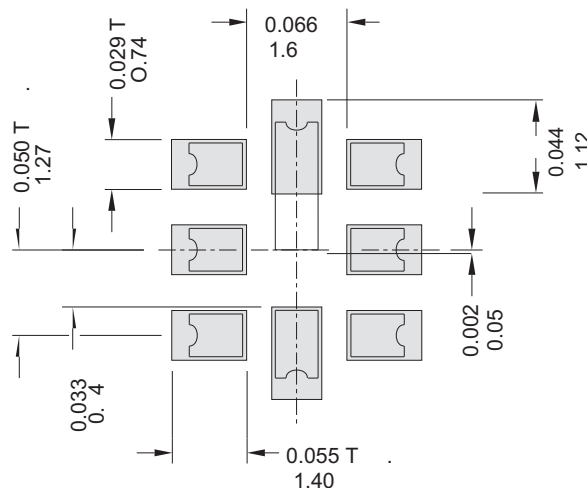

Tape and Reel Specifications

Tape and Reel Standard per ANSI/EIA-481

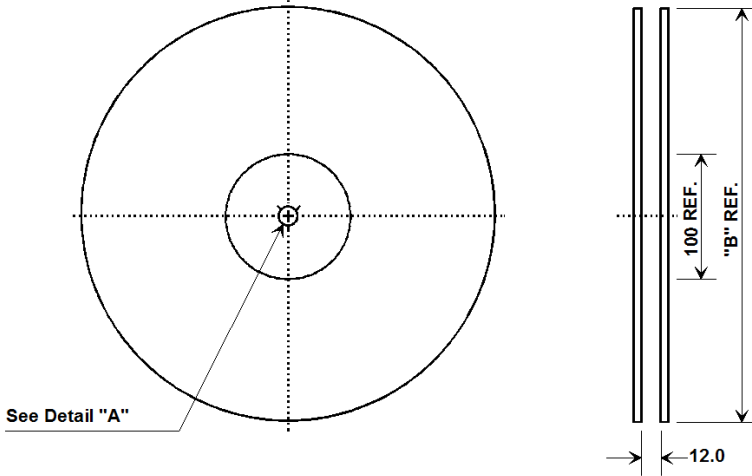

"B "		Quantity Per Reel
Nominal Size		
Inches	millimeters	
7	178	500
13	330	3000

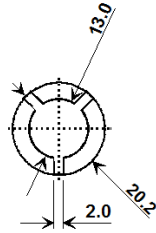

COMPONENT ORIENTATION and DIMENSIONS

Carrier Tape Dimensions	
Ao	4.25 mm
Bo	4.25 mm
Ko	1.30 mm
Pitch	8.0 mm
W	12.0 mm

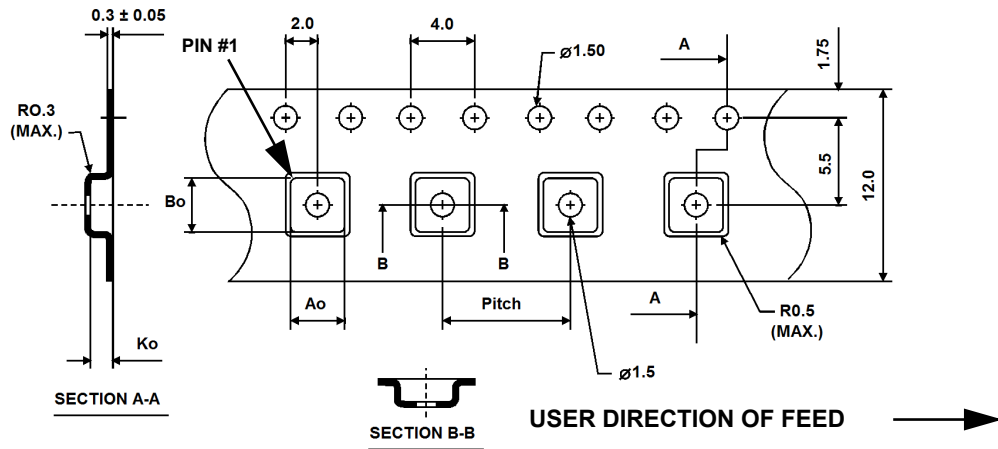

Recommended Reflow Profile

1. Preheating shall be fixed at 150~180°C for 60~90 seconds.
2. Ascending time to preheating temperature 150°C shall be 30 seconds min.
3. Heating shall be fixed at 220°C for 50~80 seconds and at 260°C +0/-5°C peak (10 seconds).
4. Time: 5 times maximum.

