



3

YEARS
WARRANTY

ROHS
COMPLIANT

REACH
COMPLIANT

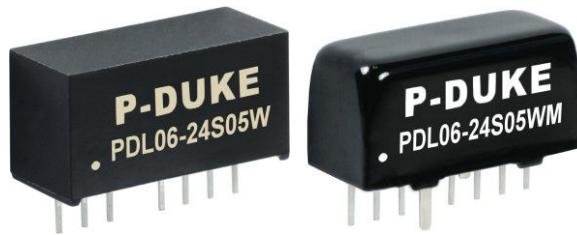

Automation



Datacom



IPC



Industry



Measurement



Telecom



Automobile



Boat



Charger



Medical



PV



Railway



3000
VDC
Isolation
Voltage

1600
VDC
Isolation
Voltage

4 : 1
Wide
Input
Range

LOW
Standby
Power

NO
Min. Load
Required

REMOTE
ON
OFF

OCP

SCP

PART NUMBER STRUCTURE

PDL06	-	48	S	05	W	H	-	M3
Series Name		Input Voltage (VDC)	Output Quantity	Output Voltage (VDC)	Input Range	Case & Isolation Options		Operating Temp. Options
		24:9~36 48:18~75	S: Single D: Dual	3P3:3.3 05:5 09:9 12:12 15:15 24:24 05:±5 12:±12 15:±15	4 : 1	□: Standard type Plastic case 1600VDC isolation H: Plastic case 3000VDC isolation M: Metal case 1600VDC isolation		□: Standard -40~+100°C With derating M3: M3 Version Plastic case -55~+100°C With derating Metal case -55~+100°C With derating

TECHNICAL SPECIFICATION All specifications are typical at nominal input, full load and 25°C unless otherwise noted

Model Number	Input Range	Output Voltage	Output Current @ Full Load	Input Current @ No Load	Efficiency	Maximum Capacitor Load
	VDC	VDC	mA	mA	%	μF
PDL06-24S3P3W	9 ~ 36	3.3	1500	4	81	2200
PDL06-24S05W	9 ~ 36	5	1200	4	84	1100
PDL06-24S09W	9 ~ 36	9	666	4	86	680
PDL06-24S12W	9 ~ 36	12	500	4	87	470
PDL06-24S15W	9 ~ 36	15	400	4	88	470
PDL06-24S24W	9 ~ 36	24	250	4	87	180
PDL06-24D05W	9 ~ 36	±5	±600	6	84	±680
PDL06-24D12W	9 ~ 36	±12	±250	6	87	±330
PDL06-24D15W	9 ~ 36	±15	±200	8	87	±180
PDL06-48S3P3W	18 ~ 75	3.3	1500	4	81	2200
PDL06-48S05W	18 ~ 75	5	1200	4	84	1100
PDL06-48S09W	18 ~ 75	9	666	4	85	680
PDL06-48S12W	18 ~ 75	12	500	4	87	470
PDL06-48S15W	18 ~ 75	15	400	4	87	470
PDL06-48S24W	18 ~ 75	24	250	4	87	180
PDL06-48D05W	18 ~ 75	±5	±600	6	84	±680
PDL06-48D12W	18 ~ 75	±12	±250	6	87	±330
PDL06-48D15W	18 ~ 75	±15	±200	8	87	±180

INPUT SPECIFICATIONS

Parameter	Conditions	Min.	Typ.	Max.	Unit
Operating input voltage range	24Vin(nom)	9	24	36	VDC
	48Vin(nom)	18	48	75	
Start up time	Constant resistive load	Power up	30		ms
		Remote ON/OFF	30		
Input surge voltage	1 second, max.	24Vin(nom)		50	VDC
		48Vin(nom)		100	
Input filter			Capacitor type		
Remote ON/OFF	Referred to –Vin pin	DC-DC ON		Open or 0 ~ 0.5VDC	
		DC-DC OFF		3 ~ 12VDC	
		Input current of Ctrl pin	0.5	3.5	mA
		Remote off input current		2.5	mA

OUTPUT SPECIFICATIONS						
Parameter	Conditions		Min.	Typ.	Max.	Unit
Voltage accuracy			-1.0		+1.0	%
Line regulation	Low Line to High Line at Full Load		-0.2		+0.2	%
Load regulation	No Load to Full Load	Single	-0.5		+0.5	%
		Dual	-1.0		+1.0	
Cross regulation	Asymmetrical load 25%/100% FL	Dual	-5.0		+5.0	%
Ripple and noise	20MHz bandwidth	3.3Vout 5Vout, 9Vout		50		mVp-p
		12Vout, 15Vout 24Vout		75		
Temperature coefficient			-0.02		+0.02	%/°C
Transient response recovery time	25% load step change			250		µs
Over load protection	% of Iout rated; Hiccup mode			180		%
Short circuit protection						Continuous, automatic recovery

GENERAL SPECIFICATIONS						
Parameter	Conditions		Min.	Typ.	Max.	Unit
Isolation voltage	1 minute	Input to Output	1600			VDC
		Standard Type	3000			
		Suffix "H"	1600			
Isolation resistance	500VDC	Input (Output) to Case	1000			GΩ
		Suffix "M"	1			
Isolation capacitance					50	pF
		Standard Type			50	
		Suffix "H"			50	
Switching frequency			522	580	638	kHz
Safety approvals	IEC/ EN/ UL62368-1		UL:E193009 CB:UL(Demko)			
Case material			Standard Type			Non-conductive black plastic Non-conductive black plastic Copper
		Suffix "H"				
		Suffix "M"				
Base material						None
Potting material						Silicone (UL94 V-0)
Weight			Standard Type		4.8g (0.17oz)	
			Suffix "H"		4.8g (0.17oz)	
			Suffix "M"		5.9g (0.21oz)	
MTBF	MIL-HDBK-217F	Standard Type			2.928 x 10 ⁶ hrs	
		Suffix "H"			2.928 x 10 ⁶ hrs	
		Suffix "M"			3.161 x 10 ⁶ hrs	

ENVIRONMENTAL SPECIFICATIONS						
Parameter	Conditions		Min.	Typ.	Max.	Unit
Operating ambient temperature	Standard type	With derating	-40		+100	°C
		Suffix "H"	-40		+100	
		Suffix "M"	-40		+100	
	M3 Version	Suffix "H"	-55		+100	
		Suffix "M"	-55		+100	
Maximum case temperature					100	°C
Storage temperature range			-55		+125	°C
Thermal shock						MIL-STD-810F
Vibration						MIL-STD-810F
Relative humidity						5% to 95% RH

EMC SPECIFICATIONS			
Parameter	Conditions		Level
EMI	EN55032	With external components	Class A · Class B
EMS	EN55035		
ESD	EN61000-4-2	Air \pm 8kV and Contact \pm 6kV	Perf. Criteria A
Radiated immunity	EN61000-4-3	20 V/m	Perf. Criteria A
Fast transient	EN61000-4-4	\pm 2kV	Perf. Criteria A
	PDL06-24□□□W	With an aluminum electrolytic capacitor (Nippon chemi-con KY series, 220 μ F/100V) and a TVS (SMDJ70A, 70V, 3000Watt peak pulse power) in parallel	
	PDL06-48□□□W	With an aluminum electrolytic capacitor (Nippon chemi-con KY series, 220 μ F/100V) and a TVS (SMDJ120A, 120V, 3000Watt peak pulse power) in parallel.	
Surge	EN61000-4-5	\pm 2kV	Perf. Criteria A
	PDL06-24□□□W	With an aluminum electrolytic capacitor (Nippon chemi-con KY series, 220 μ F/100V) and a TVS (SMDJ70A, 70V, 3000Watt peak pulse power) in parallel	
	PDL06-48□□□W	With an aluminum electrolytic capacitor (Nippon chemi-con KY series, 220 μ F/100V) and a TVS (SMDJ120A, 120V, 3000Watt peak pulse power) in parallel.	
Conducted immunity	EN61000-4-6	10 Vr.m.s	Perf. Criteria A
Power frequency magnetic field	EN61000-4-8	100A/m continuous; 1000A/m 1 second	Perf. Criteria A

CAUTION: This power module is not internally fused. An input line fuse must always be used.

CHARACTERISTIC CURVE

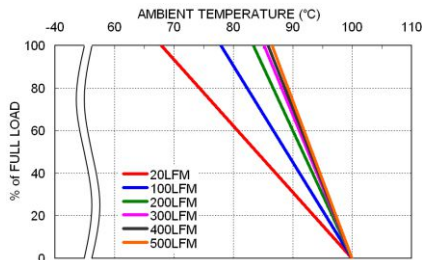

PDL06-48S05W Derating Curve

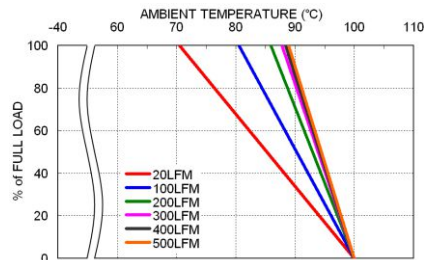

PDL06-48S05WM Derating Curve

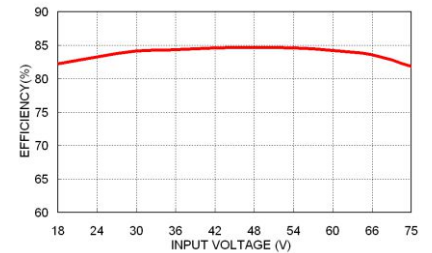

PDL06-48S05W Efficiency vs. Input Voltage

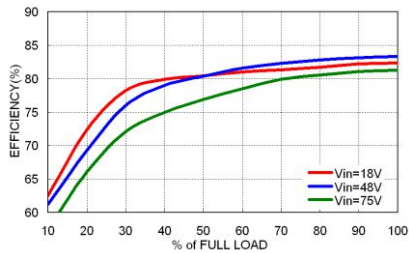

PDL06-48S05W Efficiency vs. Output Load

FUSE CONSIDERATION

This power module is not internally fused. An input line fuse must always be used.

This encapsulated power module can be used in a wide variety of applications, ranging from simple stand-alone operation to an integrated part of sophisticated power architecture.

To maximum flexibility, internal fusing is not included; however, to achieve maximum safety and system protection, always use an input line fuse.

The input line fuse suggest as below :

Model	Fuse Rating (A)	Fuse Type
PDL06-24□□□W	1.6	Slow-Blow
PDL06-48□□□W	1	Slow-Blow

The table based on the information provided in this data sheet on inrush energy and maximum DC input current at low Vin.

MECHANICAL DRAWING

Standard type, Suffix "H"

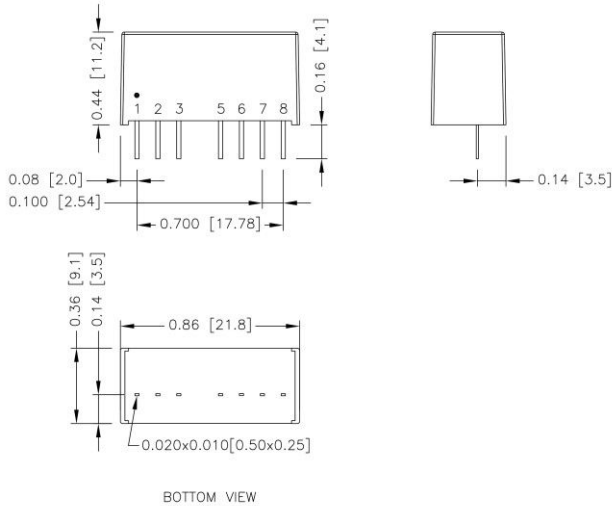

PIN CONNECTION

PIN	SINGLE	DUAL
1	-Vin	-Vin
2	+Vin	+Vin
3	Ctrl	Ctrl
5	NC*/No pin**	NC*/No pin**
6	+Vout	+Vout
7	-Vout	Common
8	NC	-Vout

*NC pin for standard type model.

**No pin for 3kVDC isolation model (suffix "H").

1. All dimensions in inch [mm]
2. Tolerance :x.xx±0.02 [x.x±0.5]
x.xxx±0.01 [x.xx±0.25]
3. Pin dimension tolerance ±0.004 [0.10]

Suffix "M"

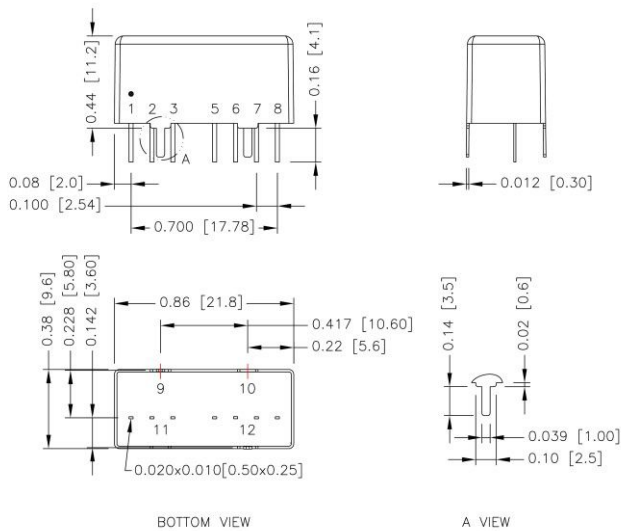

PIN CONNECTION

PIN	SINGLE	DUAL
1	-Vin	-Vin
2	+Vin	+Vin
3	Ctrl	Ctrl
5	NC	NC
6	+Vout	+Vout
7	-Vout	Common
8	NC	-Vout
9	Case	Case
10	Stand off	Stand off
11	Stand off	Stand off
12	Case	Case

1. All dimensions in inch [mm]
2. Tolerance :x.xx±0.02 [x.x±0.5]
x.xxx±0.01 [x.xx±0.25]
3. Pin dimension tolerance ±0.004 [0.10]

* Case pins should not be connected to any circuit.

RECOMMENDED PAD LAYOUT

Standard type, Suffix “H”

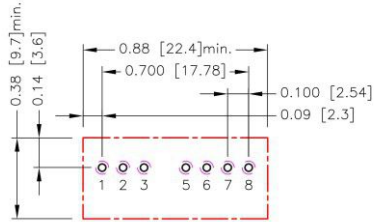

All dimensions in inch[mm]
 Pad size(lead free recommended)
 Through hole 1.2.3.5.6.7.8: $\Phi 0.031$ [0.80]
 Top view pad 1.2.3.5.6.7.8: $\Phi 0.039$ [1.00]
 Bottom view pad 1.2.3.5.6.7.8: $\Phi 0.063$ [1.60]

Suffix “M”

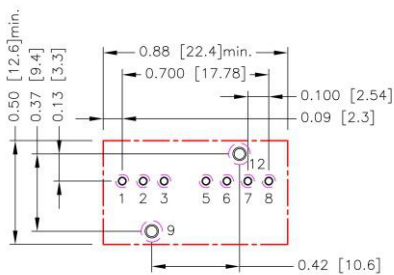

All dimensions in inch[mm]
 Pad size(lead free recommended)
 Through hole 1.2.3.5.6.7.8: $\Phi 0.031$ [0.80]
 Through hole 9.12: $\Phi 0.051$ [1.30]
 Top view pad 1.2.3.5.6.7.8: $\Phi 0.039$ [1.00]
 Top view pad 9.12: $\Phi 0.064$ [1.63]
 Bottom view pad 1.2.3.5.6.7.8: $\Phi 0.063$ [1.60]
 Bottom view pad 9.12: $\Phi 0.102$ [2.60]

THERMAL CONSIDERATIONS

The power module operates in a variety of thermal environments. However, sufficient cooling should be provided to help ensure reliable operation of the unit. Heat is removed by conduction, convection, and radiation to the surrounding environment. Proper cooling can be verified by measuring the point as the figure below. The temperature at this location should not exceed “Maximum case temperature”. When operating, adequate cooling must be provided to maintain the test point temperature at or below “Maximum case temperature”. You can limit this temperature to a lower value for extremely high reliability.

- Thermal test condition with vertical direction by natural convection (20LFM).

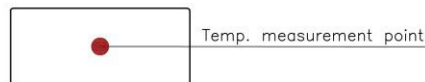

TOP VIEW