

MVB. Vertical toggle clamps

with straight base, steel or stainless steel



- 1
- 2
- 3
- 4
- 5
- 6
- 7
- 8
- 9
- 10
- 11
- 12
- 13
- 14
- 15
- 16
- 17
- 18

STANDARD EXECUTIONS

- **MVB-B:** C10 zinc-plated steel, zinc-plated steel rivets. Open clamping lever and two folded washers.
- **MVB-F:** C10 zinc-plated steel, zinc-plated steel rivets. Solid clamping lever and bolt retainer.
- **MVB-BX:** AISI 304 stainless steel. Open clamping lever and two folded washers.
- **MVB-FX:** AISI 304 stainless steel. Solid clamping lever and bolt retainer.

SUPPORT BUSHING

Ground and hardened steel.

HANDLE

Polyurethane, red colour.

CLAMPING BOLTS

To be ordered separately.

FEATURES AND APPLICATIONS

All articulated joints are lubricated with special grease. During clamping, the lever is controlled to prevent impact on functioning due to side thrust. The new geometry of MVB vertical toggle clamps gives them additional strength, their lifespan is significantly increased with the addition of hardened steel support bushings as well as several other forms of reinforcement. Slotted assembly holes for applications in inches.

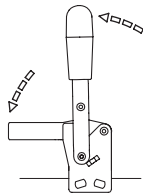

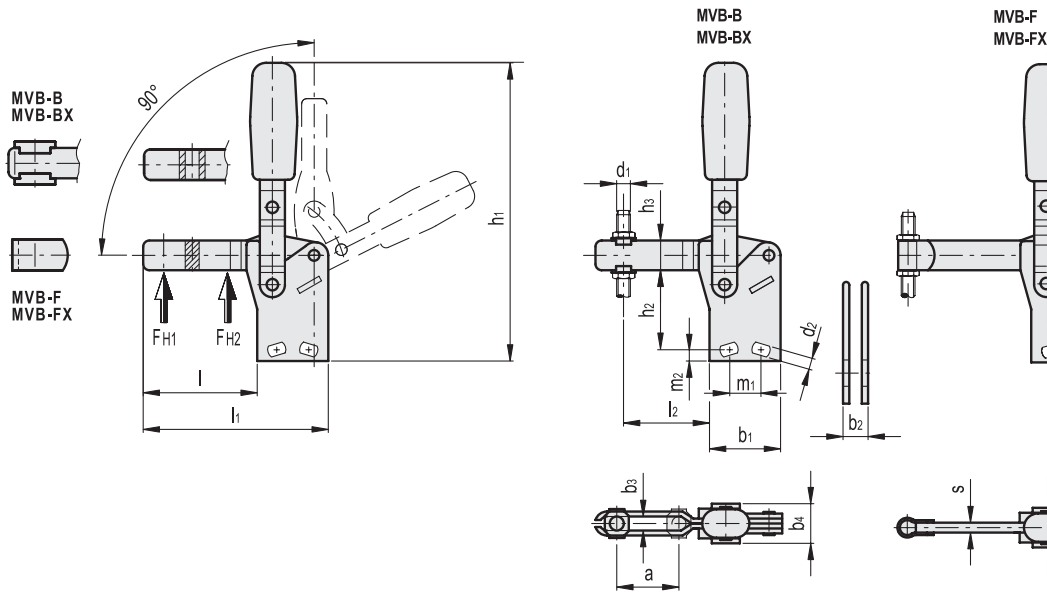

MVB-B

METRIC

Code	Description	a	b1	b2	b3	b4	d1	d2	h1	h2	h3	l	l1	l2	m1	m2	FH1 [N]*	FH2 [N]*	⚖
GG.AA522	MVB.75-B	20	29	8	5.2	16	M5	4.5	109.5	27	11	37.5	66.5	31.5	15+16	5	750	1600	98
GG.AA532	MVB.130-B	28	35	10	6.2	20	M6	5.5	156	35	16	50	85	42	12.5+19	6.5	1050	1750	230
GG.AA542	MVB.230-B	40	43	12	8.5	23	M8	6.5	183	41.5	18	67.5	110.5	58	19+20	6.5	2000	3520	380
GG.AA552	MVB.330-B	43	50	14	10.5	25	M10	8.5	218	56.5	22	79	129	76	29+32	9.5	2400	4000	620
GG.AA562	MVB.430-B	64	58	18	12.5	34	M12	8.5	267.5	67.5	26	106	164	104	32	10	2800	5000	1110
GG.AA572	MVB.530-B	90	77	18	12.5	34	M12	12.5	337	105	32	146	223	144	50+51	12.5	4500	8750	1920

MVB-F

METRIC

Code	Description	b1	b2	b4	d1	d2	h1	h2	h3	l	l1	m1	m2	s	FH1 [N]*	FH2 [N]*	⚖
GG.AA526	MVB.75-F	29	8	16	M5	4.5	109.5	27	11	38	67	15+16	5	4	750	1160	100
GG.AA536	MVB.130-F	35	10	20	M6	5.5	156	35	16	51	86	12.5+19	6.5	5	1050	1750	235
GG.AA546	MVB.230-F	43	12	23	M8	6.5	183	41.5	18	69	112	19+20	6.5	6	2000	3200	390
GG.AA556	MVB.330-F	50	14	25	M10	8.5	218	56.5	22	80.5	130.5	29+32	9.5	7	2400	4000	620
GG.AA566	MVB.430-F	58	18	34	M12	8.5	267.5	67.5	26	108	166	32	10	10	2800	5000	1110
GG.AA576	MVB.530-F	77	18	34	M12	12.5	337	105	32	148	225	50+51	12.5	10	4500	8000	1920

MVB-BX

INOX STAINLESS STEEL

METRIC

Code	Description	a	b1	b2	b3	b4	d1	d2	h1	h2	h3	l	l1	l2	m1	m2	FH1 [N]*	FH2 [N]*	⚖
GG.AS100	MVB.75-BX	20	29	8	5.2	16	M5	4.5	109.5	27	11	37.5	66.5	31.5	15+16	5	750	1600	98
GG.AS155	MVB.130-BX	28	35	10	6.2	20	M6	5.5	156	35	16	50	85	42	12.5+19	6.5	1050	1750	230
GG.AS185	MVB.230-BX	40	43	12	8.5	23	M8	6.5	183	41.5	18	67.5	110.5	58	19+20	6.5	2000	3200	380

MVB-FX

INOX STAINLESS STEEL

METRIC

Code	Description	b1	b2	b4	d1	d2	h1	h2	h3	l	l1	m1	m2	s	FH1 [N]*	FH2 [N]*	⚖
GG.AS110	MVB.75-FX	29	8	16	M5	4.5	109.5	27	11	38	67	15+16	5	4	750	1600	100
GG.AS165	MVB.130-FX	35	10	20	M6	5.5	156	35	16	51	86	12.5+19	6.5	5	1050	1750	235
GG.AS195	MVB.230-FX	43	12	23	M8	6.5	183	41.5	18	69	112	19+20	6.5	6	2000	3200	390

* Holding force.

