

# RSB1 Alloy Steel Low Profile Load Cell

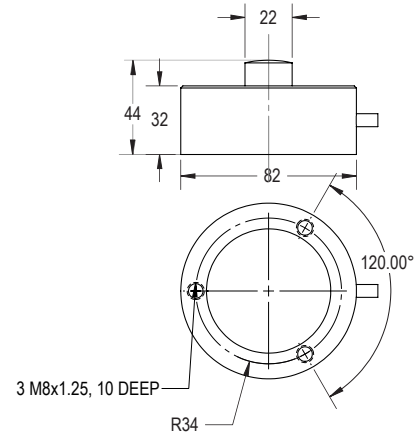

(All dimensions are in mm)

## Accuracy Specifications

Accuracy	
Non-linearity	± 0.05% of Full Scale
Hysteresis	± 0.05% of Full Scale
Non-repeatability	± 0.03% of Full Scale

## Load Cell Specifications

Zero Balance	± 2%
Safe Overload	to 150% of capacity (300% Ultimate Overload)
Rated Excitation	5 - 10 VDC
Full Scale Output	3 mV/V
Connections	2m Cable
Input Impedance	385 ± 30 Ohm
Output Impedance	350 ± 4 Ohm
Insulation	> 2,000 MΩ
Creep, in 30 min	± 0.05% of Load
Operating Temperature Range	-20°C to 60°C with TARE
Compensated Temperature Range	-10°C to 40°C with TARE
Temperature Effect on Output	0.02% of Full Scale/10°C
Temperature Effect on Zero	0.02% of Full Scale/10°C
Seal Type	IP66

## Compatible Accessories

### Recommended Interfaces



#### USB Interface

1 Channel:  
DI-100U (40 Hz)  
DI-100UHS (250 Hz)  
DI-1000U (60 Hz)  
DI-1000UHS (500 Hz)  
DI-10000UHS-1K (1 KHz)  
DI-10000UHS-10K (50 KHz)

4 Channel:  
DI-400U (40 Hz)  
DI-400UHS (250 Hz)

#### Wireless Interface

DI-1000ZP  
DI-1000WiFi  
DI-1000BLE

#### Analog Interface

AI-1000 (0-5 VDC)  
AI-1000CV (0-5 VDC, 4-20 mA)

#### Touchscreen Display

DS-3000Pro-1 (1 Channel)  
DS-3000Pro-4 (4 Channel)

## Wiring Information

Cable Color Code	
Red	+ Excitation
Black	- Excitation
Green	+ Signal
White	- Signal

## Ordering Information

Multiple Load Cell Capacities	
RSB1	Part No.
2000 kilogram	RSB1-02KM-S
5000 kilogram	RSB1-05KM-S

## Calibration Options

*C01	Compression
------	-------------

## RSB2 Load Cell



To measure compression forces for lower capacities in a smaller size, see RSB2 load cell. We also offer miniature (REB5 and REB7) and sub-miniature (RSB5) load cells.

### Wireless Load Cell Configuration



### USB Load Cell Configuration

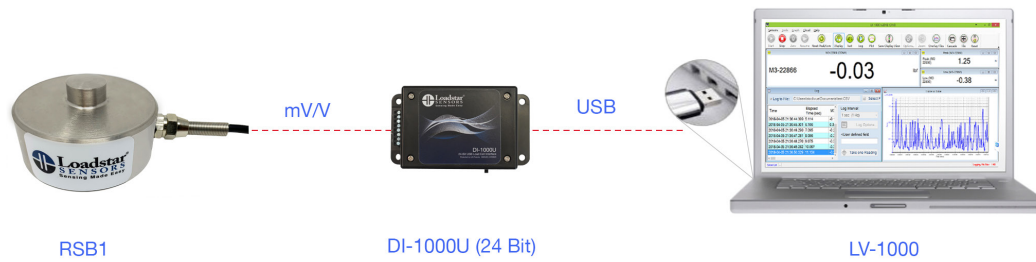
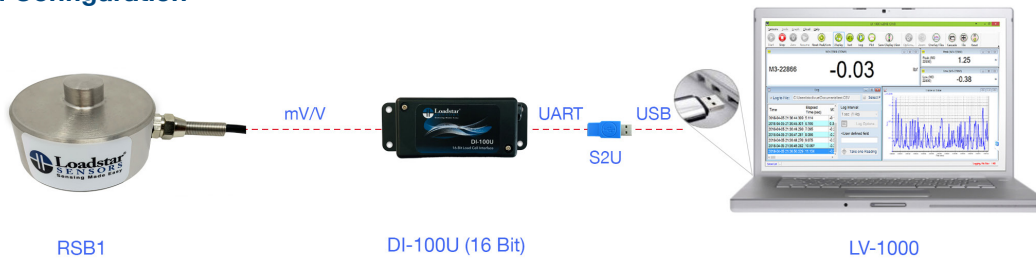

### Analog Load Cell Configuration



### Load Cell with LED Display

