



SMD CCFL Transformer

AUI15-4671

- UI15 Core SMD Package
- Extended Operating Temperature: -40°C to +125°C
- 3500VAC Hi Pot
- Unit weight: 6.1g/pc



Electrical Specifications @ 25°C					
Inductance @60KHz, 1.0V (3 - 1)	DCR (Ω) Max		Turns Ratio @ 15.75KHz, 1.0V (3-1) : (8-6)	HiPot VAC/1mA/3Sec	
160μH Min.	.621	937.3	1 : 100 ±3%	Pri-Sec 3500	Pri,Sec-Core 2000

All specifications subject to change without notice.

MECHANICAL

Dimensions: $\frac{\text{inch}}{\text{(mm)}}$

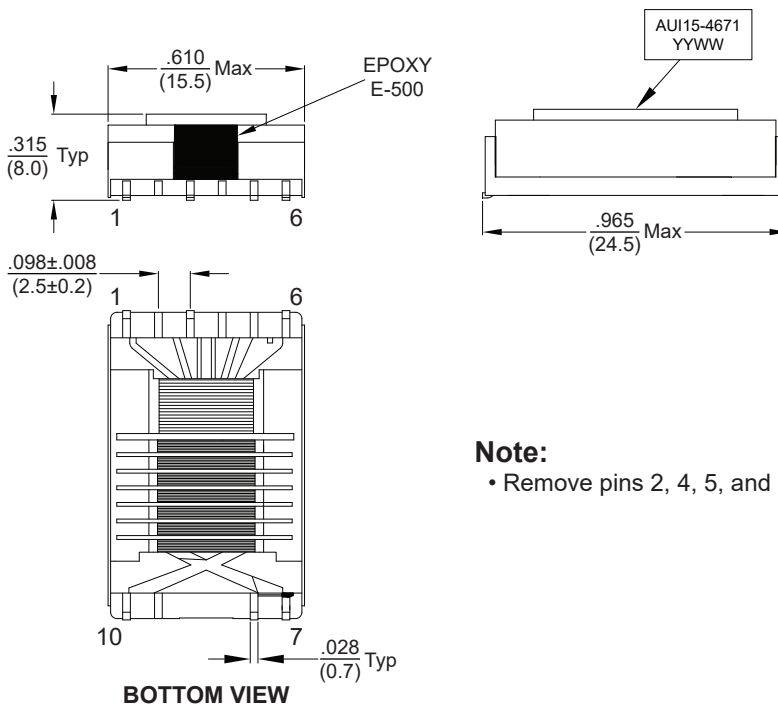

- Note:**
- Remove pins 2, 4, 5, and 9

SCHEMATIC

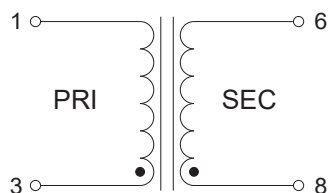

SOLDER PROFILE

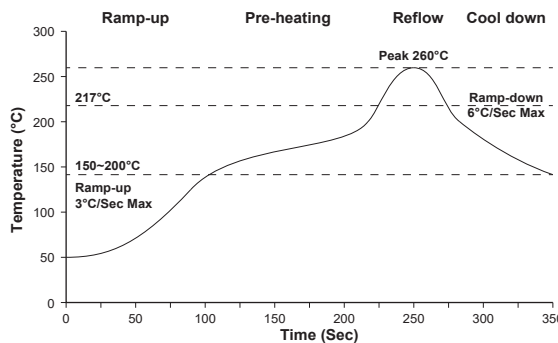

Item	Ramp-up	Pre-heating	Reflow	Peak Temp.	Cool down
Temp Scope	R.T.-150°C	150-200°C	217°C	260±5°C	PeakTemp-150°C
Time Spec.	--	60-180 Sec	60-150 Sec	20-40 Sec	--



Packaging Information

Reel Dimensions:

Dimensions: mm

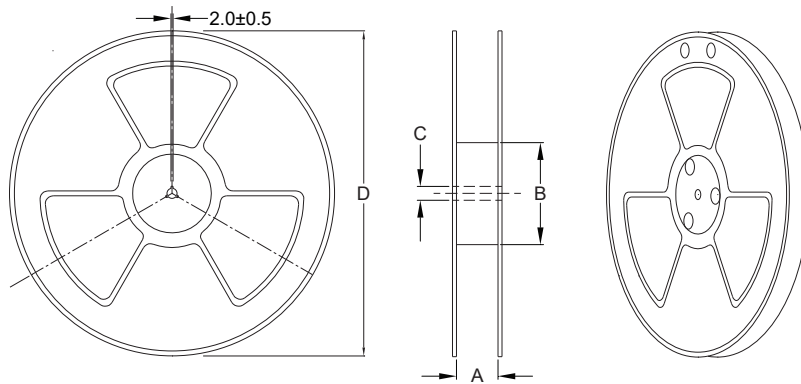

A(mm)	B(mm)	C(mm)	D(mm)
45.0±1.0	100±2.0	13.5±0.5	330

Tape Dimensions:

