



American Opto Plus LED Corp.

L233QEC-TR

2.8 x 0.8 x 1.2 Right Angle SMD LED, Tape and Reel

PACKAGE OUTLINES

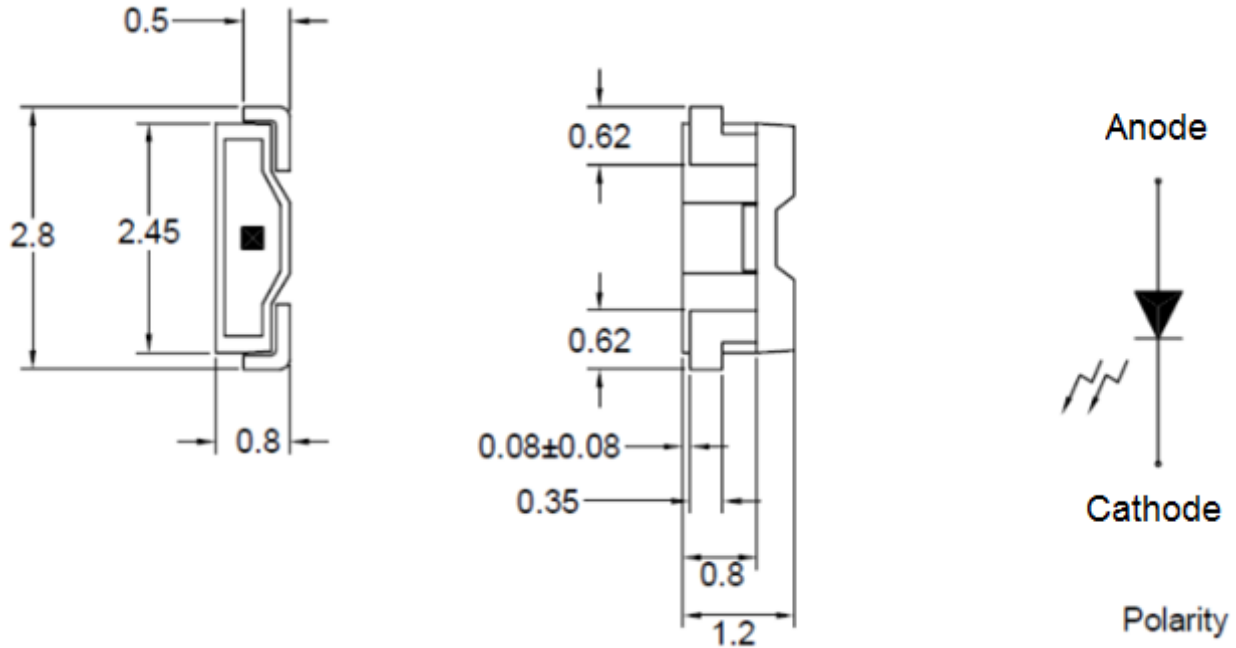

RECOMMENDED PAD LAYOUT

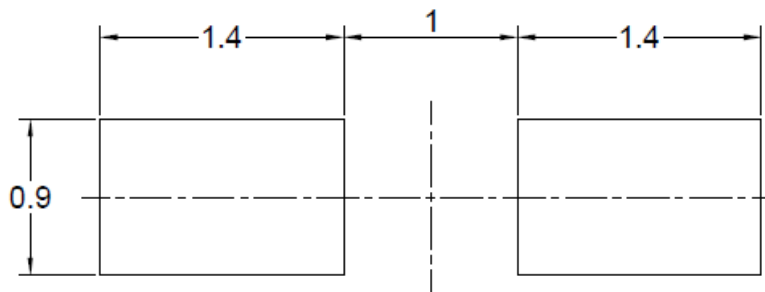

NOTES:

1. All dimensions are in millimeters tolerance is ± 0.1 mm unless otherwise noted; Angle ± 0.5

Part Number	Material	Lens Color	
		Emitted	Lens
L233QEC-TR	AlGaInP	Red	Water Clear



American Opto Plus LED Corp.

L233QEC-TR

2.8 x 0.8 x 1.2 Right Angle SMD LED, Tape and Reel

ABSOLUTE MAXIMUM RATINGS

(Ta=25°C)

Parameter	Symbol	Ratings	Unit
Power Dissipation	Pd	78	mW
Peak Forward Current (Duty 1/10@10KHz)	I _{fp}	90	mA
Forward Current	I _f	30	mA
Reverse Current @ 5V	I _r	10	μA
Electrostatic Discharge	ESD	± 500	V
Operating temperature range	T _{opr}	-40~+85	°C
Storage temperature range	T _{stg}	-40~+90	°C
Soldering Temperature	T _{sol}	Max 260°C for 5 sec	

OPTICAL-ELECTRICAL CHARACTERISTICS

(Ta=25°C)

Parameter	Symbol	Test Condition	Min	Typ	Max	Unit
Luminous Intensity	I _v	I _F =20mA	125	400	--	mcd
Peak Wavelength	λ _P		--	636	--	nm
Dominant Wavelength	λ _D		--	625	--	nm
Spectral Line Half-Width	Δλ		--	20	--	nm
Forward Voltage	V _f		1.7	--	2.6	V
Viewing angle	2θ ½		--	115	--	Deg

*Note: 1. The forward voltage data did not include ±0.1V testing tolerance.
 2. The luminous intensity data did not include ±15% testing tolerance.



American Opto Plus LED Corp.

L233QEC-TR

2.8 x 0.8 x 1.2 Right Angle SMD LED, Tape and Reel

TYPICAL ELECTRO-OPTICAL CHARACTERISTIC CURVES

Fig.1 Forward current vs. Forward Voltage

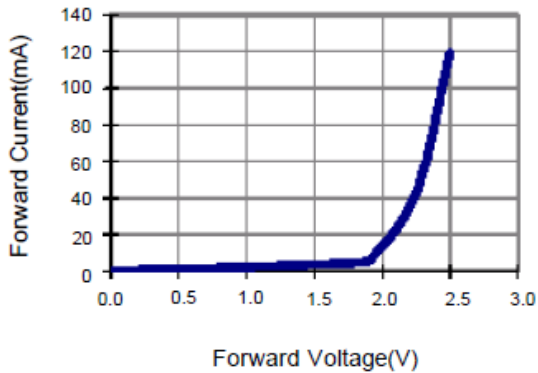

Fig.2 Relative Light Output Power vs. Forward Current

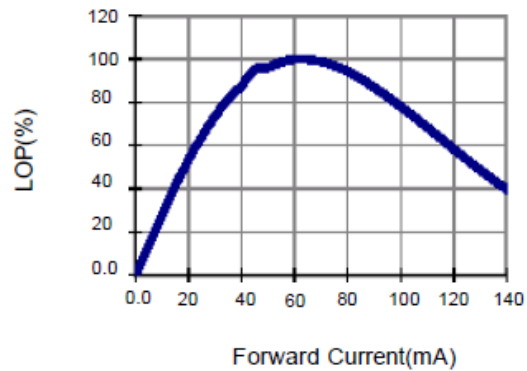

Fig.3 Forward Voltage vs. Temperature

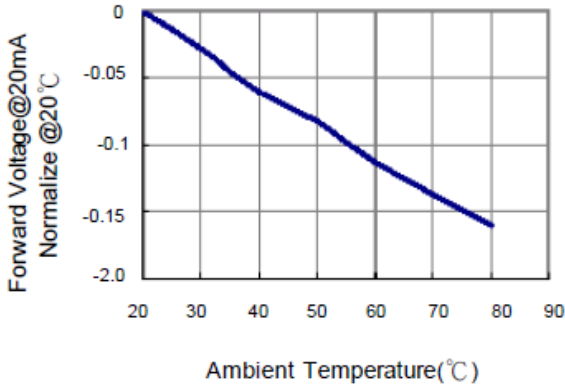

Fig.4 Relative Intensity vs. Temperature

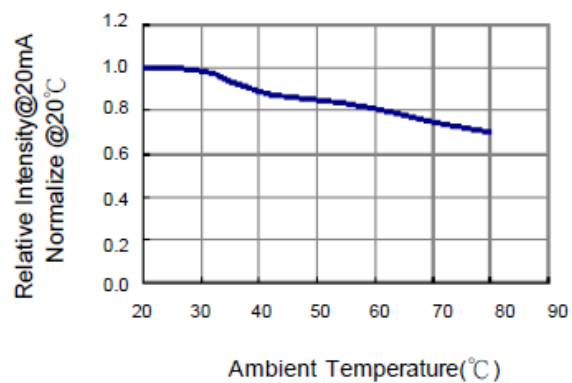

Fig.5 Relative Intensity vs. Wavelength

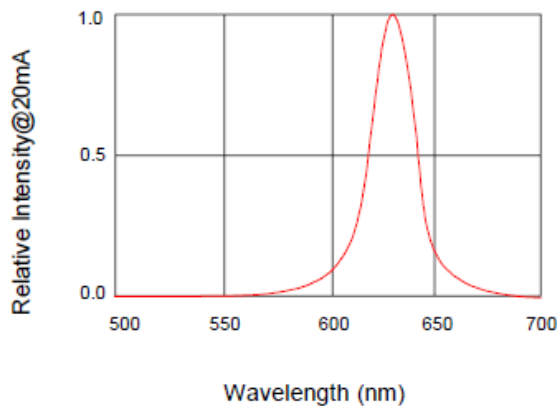
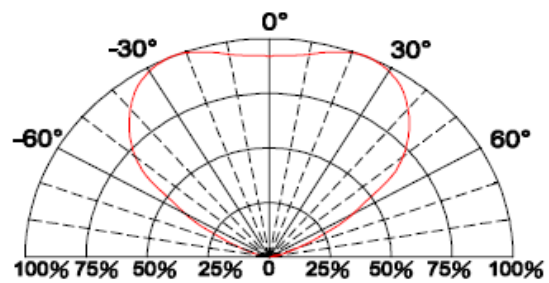

Fig.6 Directive Radiation





American Opto Plus LED Corp.

L233QEC-TR

2.8 x 0.8 x 1.2 Right Angle SMD LED, Tape and Reel

CARRIER TAPE DIMENSION

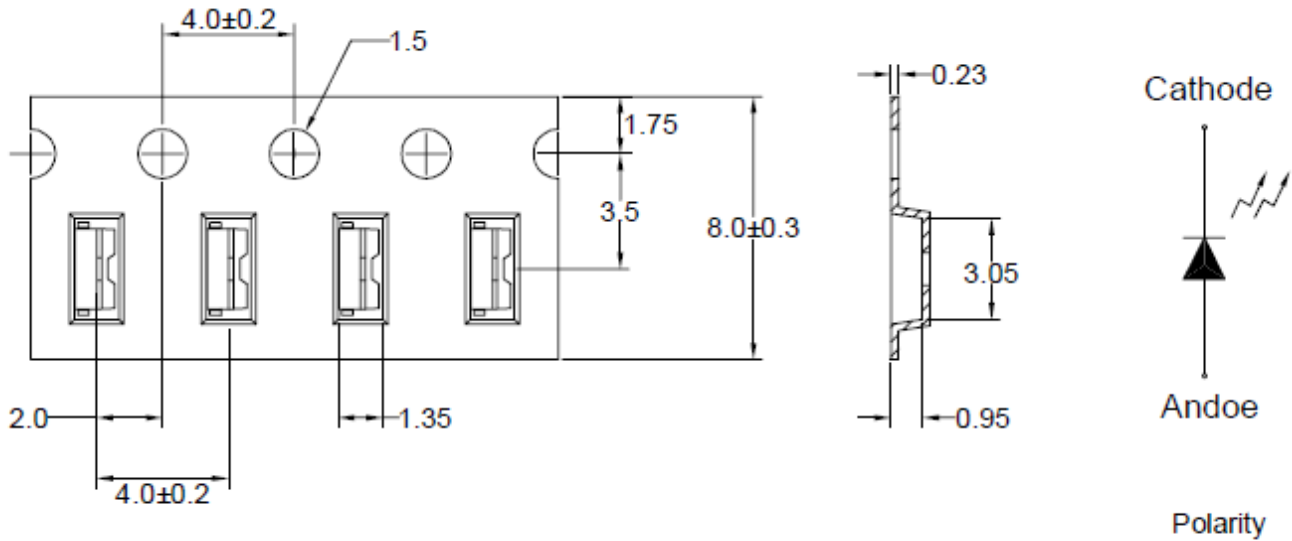

Note: The tolerances unless mentioned are ± 0.1 mm, Angle ± 0.5 ; Unit=mm

REEL DIMENSIONS

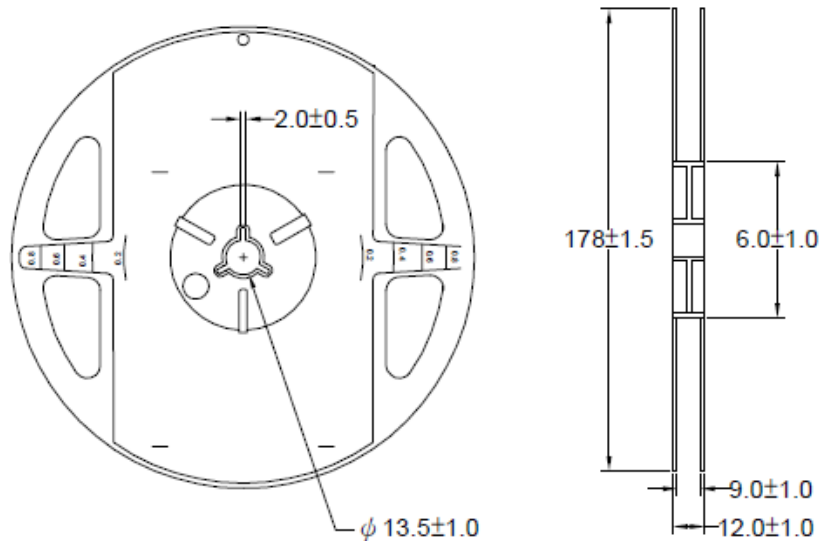

Notes:

1. 3000 pieces per reel.



American Opto Plus LED Corp. L233QEC-TR

2.8 x 0.8 x 1.2 Right Angle SMD LED, Tape and Reel

RECOMMENDED SOLDERING CONDITIONS

Basic spec is ≤ 5 seconds when 260°C .

Power dissipation of iron should be smaller than 25W, and temperature should be controllable.

Surface temperature of the device should be under 280°C for 3 seconds

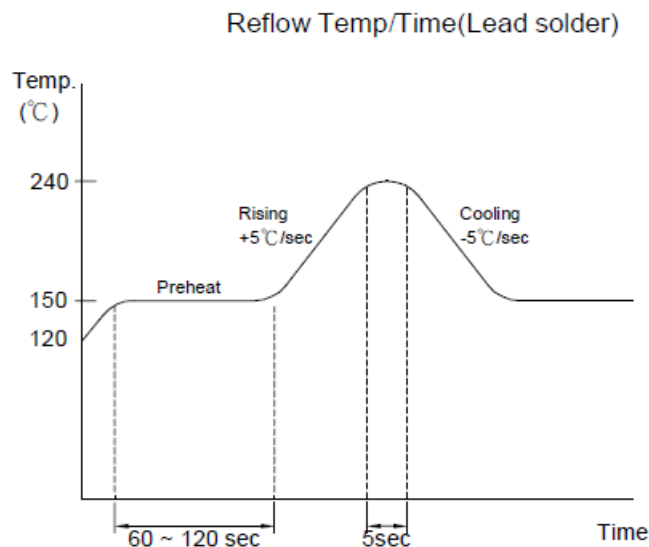
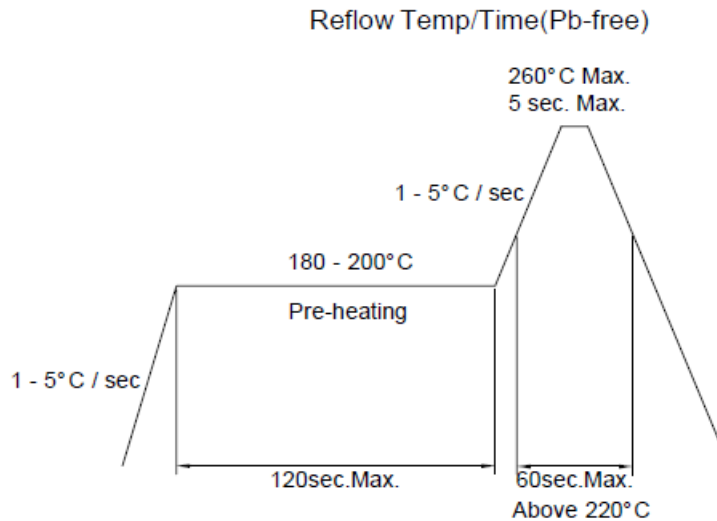

Notes:

1. Reflow soldering should not be done more than two times.
2. When soldering, do not put stress on the LEDs during heating.
3. After soldering, do not warp the circuit board.



American Opto Plus LED Corp.

L233QEC-TR

2.8 x 0.8 x 1.2 Right Angle SMD LED, Tape and Reel

PRECAUTIONS FOR USE

Storage Time:

1. The operation of temperatures and RH are: 5°C~35°C, RH60%.
2. Once the package is opened, the products should be used within a week. Otherwise, they should be kept in a damp proof box with desiccating agent. Considering the tape life, we suggest our customers to use our products within a year (from production date).
3. If opened more than one week in an atmosphere 5°C~35°C, RH60%, they should be treated at 60°C±5°C for 15hrs.

Drive Method:

LED is a current operated device, and therefore, require some kind of current limiting incorporated into the driver circuit. This current limiting typically takes the form of a current limiting resistor placed in a series with the LED.

Consider worst case voltage variations that could occur across the current limiting resistor. The forward current should not be allowed to change by more than 40% of its desired value.

Circuit model A

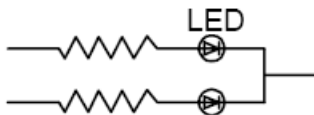

Circuit model B

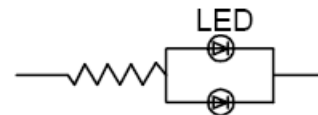

(A) Recommended circuit.

(B) The difference of brightness between LED could be found due to the VF-IF characteristics of LED.

Cleaning:

Use alcohol-based cleaning solvents such as isopropyl alcohol to clean the LED.

ESD(Electrostatic Discharge):

Static Electricity or power surge will damage the LED. Use of a conductive wrist band or anti-electrostatic glove is recommended when handling these LEDs. All devices and machinery must be properly grounded.



American Opto Plus LED Corp.

L233QEC-TR

2.8 x 0.8 x 1.2 Right Angle SMD LED, Tape and Reel

RELIABILITY TEST:

Test items and results

Classification	Test Item	Test Condition	Sample Size
Endurance Test	Operating Life Test	1.Ta=Under Room Temperature As Per Data Sheet Maximum Rating. 2.If=20mA 3.t=1000 hrs	22
	High Temperature Storage Test	1.Ta=105°C±5°C 2.t=500 hrs	22
	Low Temperature Storage Test	1.Ta=-40°C±5°C 2.t=1000 hrs	22
	High Temperature High Humidity Storage Test	1.IR-Reflow In-Board, 2 Times 2.Ta=85°C±5°C 3.RH=90%~95% 4.t=500hrs±2hrs	22
Environmental Test	Thermal Shock Test	1.IR-Reflow In-Board,2 times 2.Ta=105°C±5°C & -40°C±5°C (30min) (30min) 3.total 100 cycles	22
	Reflow Soldering Test	1.T.Sol=260°C±5°C 2.Dwell Time= 10 Max.	22
	Temperature Cycling	1.105°C ~ 25°C ~ -40°C 30mins 15mins 30mins 2.100 Cyeles	22

Criteria for judging the damage

Item	Symbol	Test Conditions	Criteria for Judgement	
			Min.	Max.
Forward Voltage	Vf	If=20mA	-	U.S.L x1.2
Reverse Current	Ir	Vr=5V	-	U.S.L x2.0
Luminous Intensity	Iv	If=20mA	L.S.L x 0.5	-

Note: 1. U.S.L.: Upper standard level 2. L.S.L.: Lower standard level

Version 1.0 Date: 3-1-2013 Specifications are subject to change without notice.

American Opto Plus LED Corp. 1206 E. Lexington Ave., Pomona CA 91766 Tel: 909-465-0080 Fax: 909-465-0130 www.aopled.com